



PSEN sl-1.0p 4.1/4.2

PILZ
THE SPIRIT OF SAFETY

► PSEN sensor technology

This document is the original document.

Where unavoidable, for reasons of readability, the masculine form has been selected when formulating this document. We do assure you that all persons are regarded without discrimination and on an equal basis.

All rights to this documentation are reserved by Pilz GmbH & Co. KG. Copies may be made for the user's internal purposes. Suggestions and comments for improving this documentation will be gratefully received.

Pilz®, PIT®, PMI®, PNOZ®, Primo®, PSEN®, PSS®, PVIS®, SafetyBUS p®, SafetyEYE®, SafetyNET p®, the spirit of safety® are registered and protected trademarks of Pilz GmbH & Co. KG in some countries.



SD means Secure Digital

Introduction	5
Validity of documentation	5
Using the documentation	5
Definition of symbols	5
Safety	6
Intended use	6
Safety regulations	7
Safety assessment	7
Use of qualified personnel	7
Warranty and liability	8
Disposal	8
For your safety	8
Unit features	9
Function description	10
Lateral and vertical offset	12
Wiring	13
Guidelines for cable length	13
Recommended cable cross sections	13
Pin assignment	14
Connection to evaluation devices	15
Connection example PNOZ s3	18
Connection example PNOZmulti	19
Teaching in the actuator	19
PSEN sl-1.0p 4.1	19
PSEN sl-1.0p 4.2	20
Installation	21
Note regarding the free-moving actuator PSEN sl-1.0fm	22
Installing on a swing gate	23
Installing on a sliding gate	24
Adjustment	25
Operation	25
Error display through flashing codes	26

Dimensions in mm	28
Technical Details Order No. 570671-570672	30
Technical Details Order No. 570674-570675	33
Supplementary data	36
Radio approval	36
Safety characteristic data	37
Classification according to ZVEI, CB24I	38
Order reference	39
Safety gate system	39
Accessories	39
EC declaration of conformity	39
UKCA-Declaration of Conformity	39

Introduction

Validity of documentation

This documentation is valid for the product PSEN sl-1.0p 4.1/4.2. It is valid until new documentation is published.

This operating manual explains the function and operation, describes the installation and provides guidelines on how to connect the product.

Using the documentation

This document is intended for instruction. Only install and commission the product if you have read and understood this document. The document should be retained for future reference.

Definition of symbols

Information that is particularly important is identified as follows:



DANGER!

This warning must be heeded! It warns of a hazardous situation that poses an immediate threat of serious injury and death and indicates preventive measures that can be taken.



WARNING!

This warning must be heeded! It warns of a hazardous situation that could lead to serious injury and death and indicates preventive measures that can be taken.



CAUTION!

This refers to a hazard that can lead to a less serious or minor injury plus material damage, and also provides information on preventive measures that can be taken.



NOTICE

This describes a situation in which the product or devices could be damaged and also provides information on preventive measures that can be taken. It also highlights areas within the text that are of particular importance.



INFORMATION

This gives advice on applications and provides information on special features.





Safety

Intended use

Safety function of safety switch:

- ▶ 2 safety outputs supply a high signal each when the corresponding input is high and the actuator is in the switch's response range.

The safety gate system meets the requirements in accordance with

- ▶ EN 60947-5-3: Pddb with the corresponding actuator PSEN sl0.5 or PSEN sl0.5fm (see Technical details: [System with normal actuator](#)  30], [System with free-moving actuator](#)  33])
- ▶ EN 62061: SIL CL 3
- ▶ EN ISO 13849-1: PL e and Cat. 4
- ▶ EN ISO 14119: Coding level High, Type 4
- ▶ The safety switch may only be used with the corresponding actuator (see Technical Details: [System with normal actuator](#)  30], [System with free-moving actuator](#)  33]).

The safety level PL e (Cat. 4)/SIL CL 3 is only achieved if

- ▶ the safety outputs use 2-channel processing.



NOTICE

Positioning of the safety switch

As the safety switch is not intended for a guard locking device for personal protection, the safeguard monitored by the safety switch must be positioned in a way that the access time corresponds at least to the machine's stopping time.

Because of the low operating distance (see [Technical details](#)  30]) the repetition accuracy of 40 % deviates from the requirement in accordance with EN 60947-5-2 (max. 10%).

Improper use

The following is deemed improper use in particular

- ▶ Any component, technical or electrical modification to the product,
- ▶ Use of the product outside the areas described in this operating manual,
- ▶ Use of the product outside the technical details (see [Technical details](#)  30]).

**NOTICE****EMC-compliant electrical installation**

The product is designed for use in an industrial environment. The product may cause interference if installed in other environments. If installed in other environments, measures should be taken to comply with the applicable standards and directives for the respective installation site with regard to interference.

**INFORMATION**

The magnet surface and counterplate may heat up. When installing, make sure that heat dissipation is guaranteed.

Safety regulations**Safety assessment**

Before using a device, a safety assessment in accordance with the Machinery Directive is required.

The product as an individual component fulfils the functional safety requirements in accordance with EN ISO 13849 and EN 62061. However, this does not guarantee the functional safety of the overall plant/machine. To achieve the relevant safety level of the overall plant/machine's required safety functions, each safety function needs to be considered separately.

Use of qualified personnel

The products may only be assembled, installed, programmed, commissioned, operated, maintained and decommissioned by persons who are competent to do so.

A competent person is a qualified and knowledgeable person who, because of their training, experience and current professional activity, has the specialist knowledge required. To be able to inspect, assess and operate devices, systems and machines, the person has to be informed of the state of the art and the applicable national, European and international laws, directives and standards.

It is the company's responsibility only to employ personnel who

- ▶ Are familiar with the basic regulations concerning health and safety / accident prevention,
- ▶ Have read and understood the information provided in the section entitled Safety
- ▶ Have a good knowledge of the generic and specialist standards applicable to the specific application.

Warranty and liability

All claims to warranty and liability will be rendered invalid if

- ▶ The product was used contrary to the purpose for which it is intended,
- ▶ Damage can be attributed to not having followed the guidelines in the manual,
- ▶ Operating personnel are not suitably qualified,
- ▶ Any type of modification has been made (e.g. exchanging components on the PCB boards, soldering work etc.).

Disposal

- ▶ In safety-related applications, please comply with the mission time T_M in the safety-related characteristic data.
- ▶ When decommissioning, please comply with local regulations regarding the disposal of electronic devices (e.g. Electrical and Electronic Equipment Act).

For your safety



DANGER!

Risk to life due to manipulation/defeat of the safeguard

If replacement actuators are obtained, these must be installed as described in the chapter entitled Installation.

If replacement actuators are used manipulatively or the function of the safeguard is defeated, there is a risk to life when operating the plant or machine! This must be considered in the operator's hazard assessment and the operator must define appropriate measures to exclude manipulation.

- ▶ Do not remove the connector's protective cap until you are just about to connect the unit. This will prevent potential contamination.

Unit features

- ▶ Transponder technology for presence detection
- ▶ Device types Pilz coding type:
 - PSEN sl-1.0p 4.1: fully coded
 - PSEN sl-1.0p 4.2: uniquely coded
- ▶ different actuators available (see [Order reference](#)  39)
 - Standard actuator PSEN sl-1.0
 - free-moving actuator PSEN sl-1.0fm for special applications with higher tolerance compensation
- ▶ Dual-channel operation
- ▶ 2 safety outputs
- ▶ 2 safety inputs for series connection of multiple safety switches
- ▶ 1 signal output
- ▶ Magnetic guard locking for process protection
- ▶ Safety outputs switch independently of the status of the magnetic guard locking device
- ▶ 1 input to switch the locking magnet on/off
- ▶ LEDs for
 - Supply voltage/fault
 - Gate closed
 - State of the inputs
 - State of the magnetic guard locking device
- ▶ M12, 8-pin male connector

Function description

Block diagram

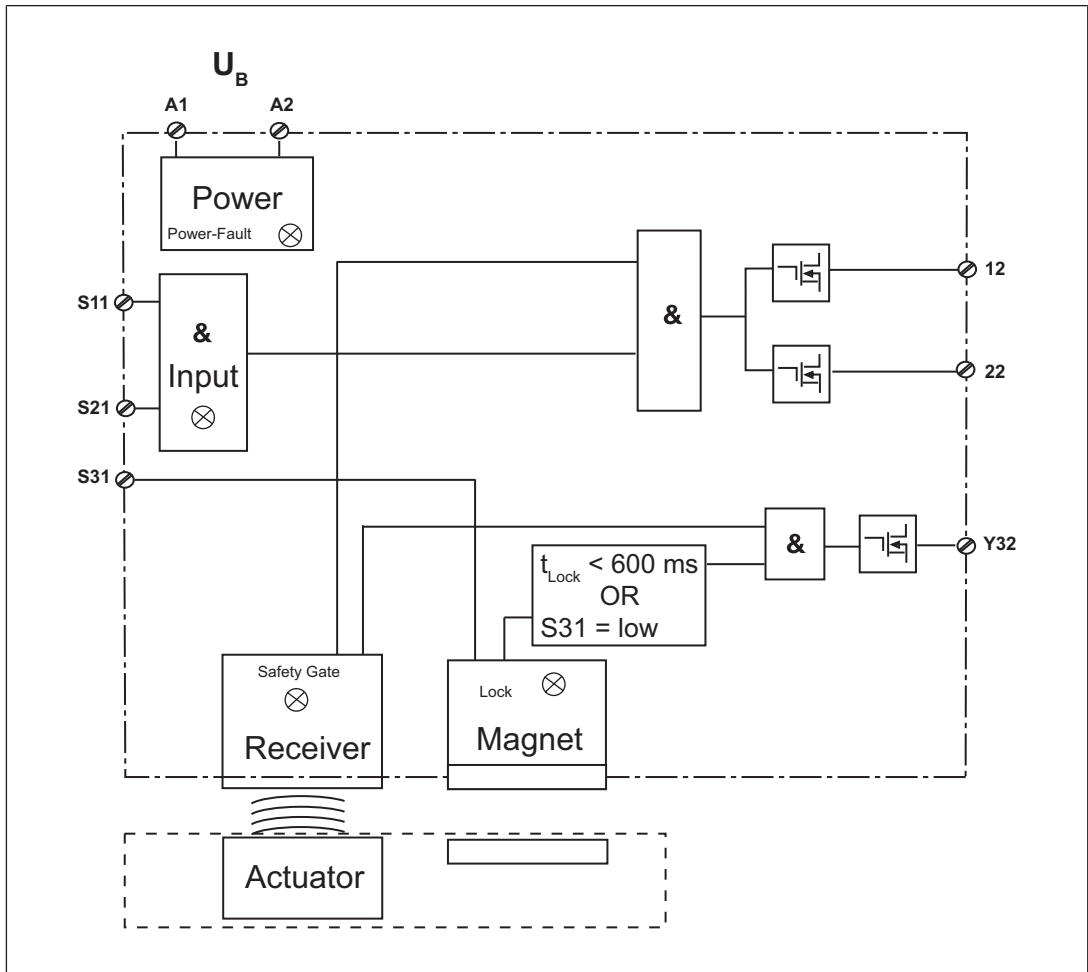

There is a high signal at safety outputs 12 and 22 if the following occur **simultaneously**:

- ▶ The actuator is within the response range (safety gate closed) and
- ▶ Inputs S11 and S21 are high.

Safety outputs 12 and 22 are low if **at least one** of the following conditions are met:

- ▶ The actuator is outside the response range or
- ▶ Inputs S11 and S21 are low.

Signal output Y32

There is a high signal at the signal output Y32 if the actuator is within the response range (safety gate closed).

The high signal is maintained if the following conditions are met simultaneously

- ▶ [1] in the timing diagram
 - Actuator is within the response range **and**
 - There is a high signal at S31 **and**
 - The holding force of the locking magnets was achieved within $t_{\text{Lock}} = 600$ ms

or

- ▶ [4] in the timing diagram
 - Actuator is within the response range **and**
 - There is a low signal at S31.

At the signal output Y32 the signal switches to low if

- ▶ The actuator leaves the response range (safety gate open) (see [3] in the timing diagram) **or**
- ▶ The holding force could not be achieved after $t_{\text{Lock}} = 600$ ms (see [2] in the timing diagram). In this case, the signal at the signal output can only switch back to high if
 - There is a low signal at input S31 for at least 500 ms **and**
 - a high signal is transmitted afterwards.

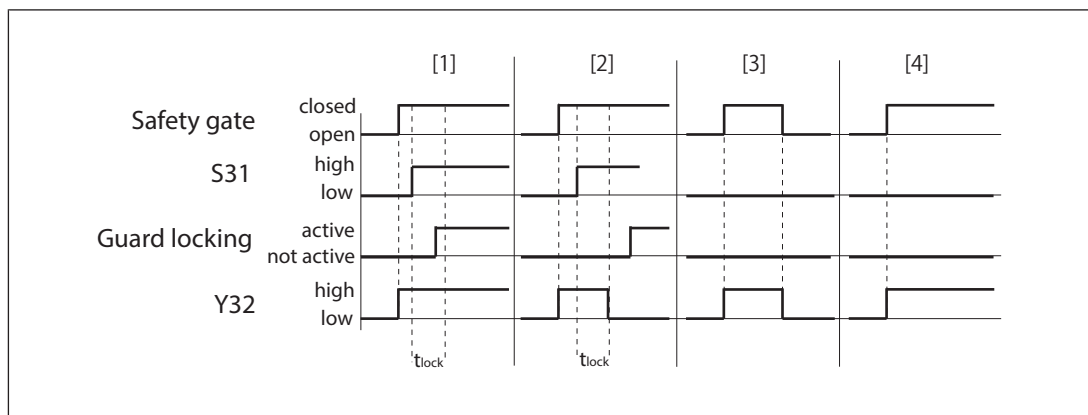

Plausibility monitoring for safety inputs S11 and S21

- ▶ If the signal at a safety input switches from high to low, while the other safety input remains high, an unequal status is displayed.
- ▶ If the signal at this input switches back from low to high, while a high signal remains at the other input, a plausibility error is displayed and a partial operation lock is triggered. The OSSDs are switched off during the partial operation lock.

A switch to a high signal will only lead to error-free safety switch operation if both inputs had a low signal simultaneously. From this moment on, the switch to high signal may occur (partial operation lock see [Error display](#) 26]).

Magnetic guard locking device and magnet monitoring

- ▶ The locking magnet is switched on if S31 (control command for magnetic guard locking) is high and the actuator is detected (safety gate closed).
- ▶ The holding force of the locking magnet is tested on power-up. If the magnet's holding force is not achieved after max. 600 ms, there will be no switch from low to high. The holding force will be tested a further 7 times.

These tests have no influence on the signal output. If the test is successful during any of these attempts, the gate is locked.

- ▶ After S31 switches to low, wait at least 500 ms until S31 is switched back to high. Also note the max. switching frequency (see Technical details: [System with normal actuator](#) [30], [System with free-moving actuator](#) [33], under electrical data).
- ▶ For physical reasons, a remanence (residual magnetism) remains after the locking magnet is switched off; this is dissipated the first time the sensor and actuator are separated. Therefore a higher effort is required when opening for the first time.
- ▶ If the safety gate is in a locked condition and is opened by force, the safety outputs will shut down.

Lateral and vertical offset

- ▶ Max. vertical offset 5 mm

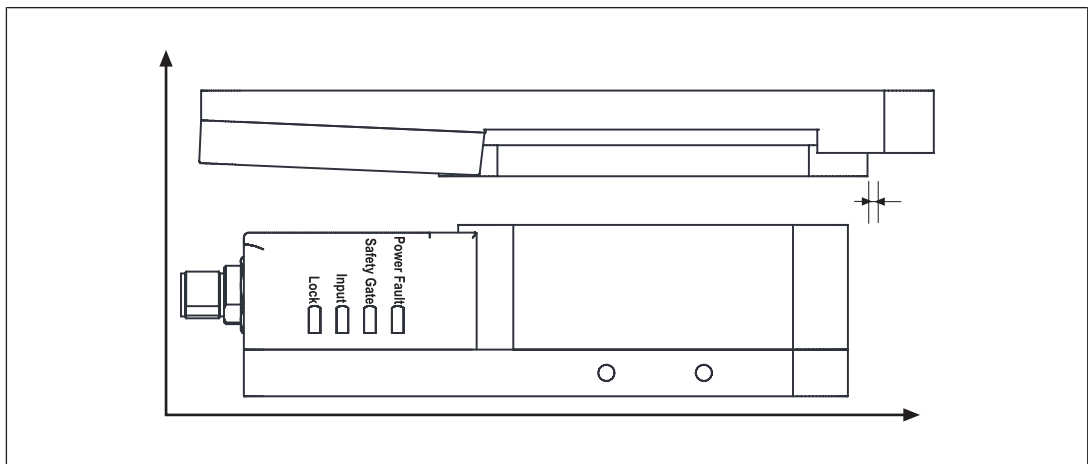

- ▶ Max. lateral offset: 3 mm

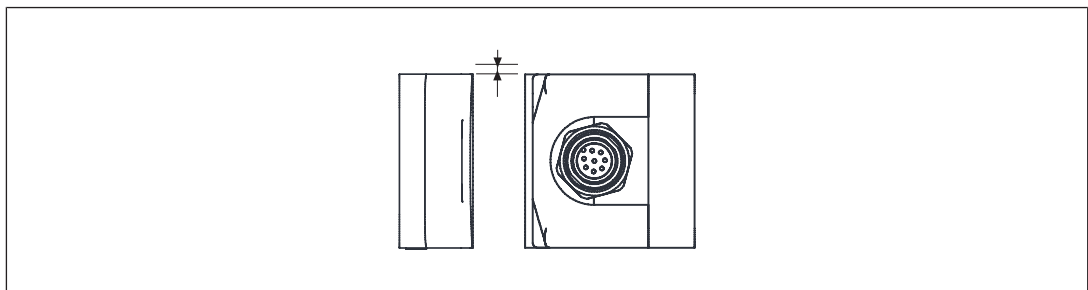

Wiring

Please note:

- ▶ You must comply with the specifications stated in the technical details (see Technical details: [System with normal actuator \[30\]](#), [System with free-moving actuator \[33\]](#)).
- ▶ The power supply must meet the regulations for extra low voltages with protective electrical separation (SELV, PELV).
- ▶ The inputs and outputs of the safety switch must have protective separation from voltages over 60 VDC.
- ▶ Ensure the wiring and EMC requirements of EN 60204-1 are met.
- ▶ Make sure you comply with the wiring technology requirements (DIN EN 60204-1) and manipulation protection requirements (EN ISO 14119).

Guidelines for cable length

The max. cable length depends on the voltage drop at the safety switches. The level of voltage drop is determined by the:

- ▶ Cable resistance
- ▶ Current of the device and the current load of the outputs

If the level of the supply voltage at the device connector falls below the minimum permitted value (see Technical details: [System with normal actuator \[30\]](#), [System with free-moving actuator \[33\]](#)), the locking magnet is no longer activated reliably. The "Lock" LED registers an error when guard locking.

Possible remedies:

- ▶ Set the supply voltage constantly to the upper tolerance range (see Technical details: [System with normal actuator \[30\]](#), [System with free-moving actuator \[33\]](#)).
- ▶ Select a higher conductor cross section
- ▶ Reduce load at the outputs, e.g. with evaluation device PNOZ e1.1p

Recommended cable cross sections

Prerequisite:

- ▶ Supply voltage: 24 V
- ▶ Cable type: LiYY 8x0.25 mm² (79 Ohm/km) from Pilz

Max. load per safety output	100 mA	500 mA
Cable length	45 m	24 m

If cable lengths greater than those stated in the table are required, please contact Pilz.

Pin assignment

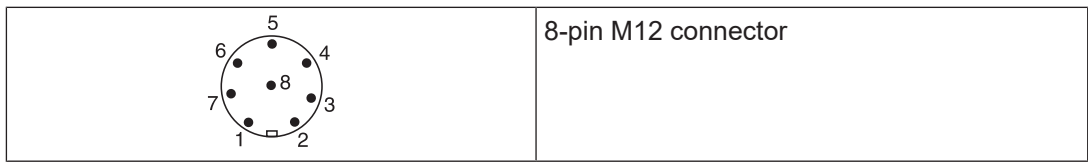

PIN	Function	Terminal designation	Cable colour (Pilz cable)
1	Input, channel 2	S21	White
2	+24 V UB	A1	Brown
3	Safety output channel 1	12	Green
4	Safety output channel 2	22	Yellow
5	Signal output "Lock"	Y32	Grey
6	Input, channel 1	S11	Pink
7	0 V UB	A2	Blue
8	"Lock_Unlock"	S31	Red

The wire colour also applies for the cable available from Pilz as an accessory.

Connection to evaluation devices

Make sure that the selected evaluation device has the following properties:

- ▶ 2-channel with feasibility monitoring
- ▶ OSSD signals are evaluated

Connection diagram, single connection

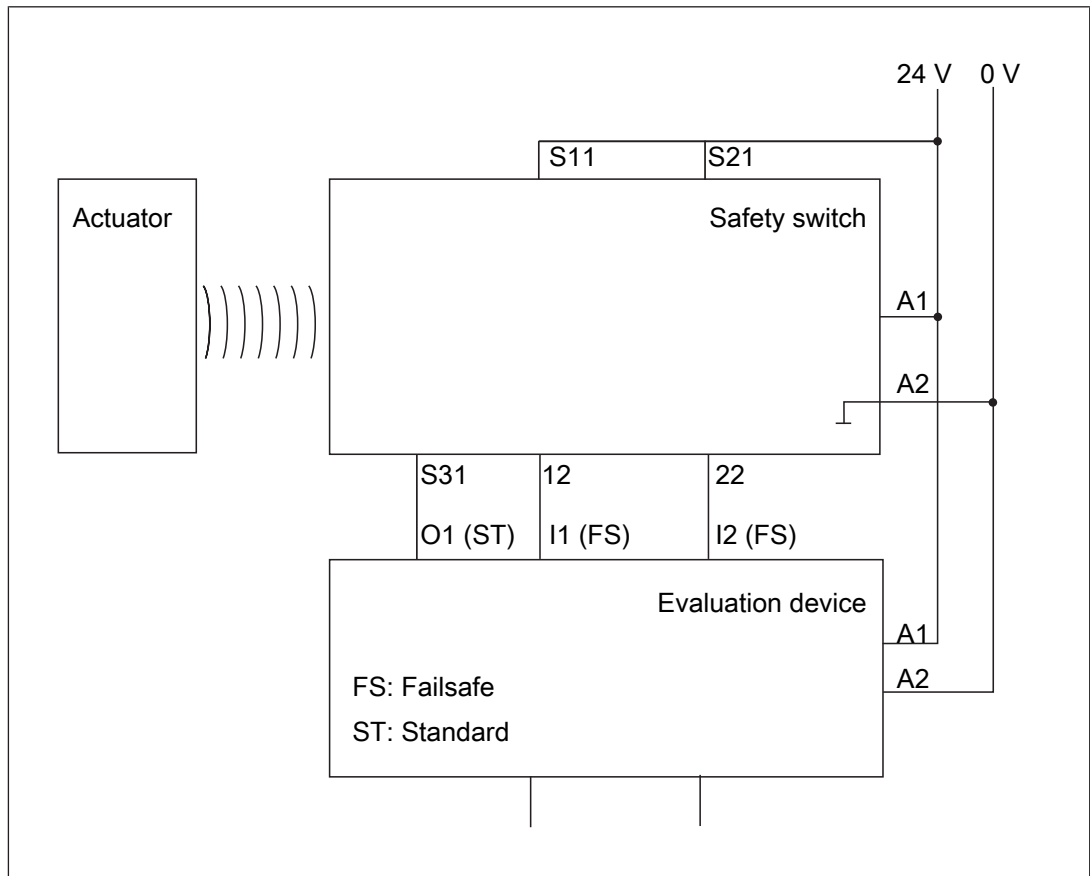

Connection diagram, series connection

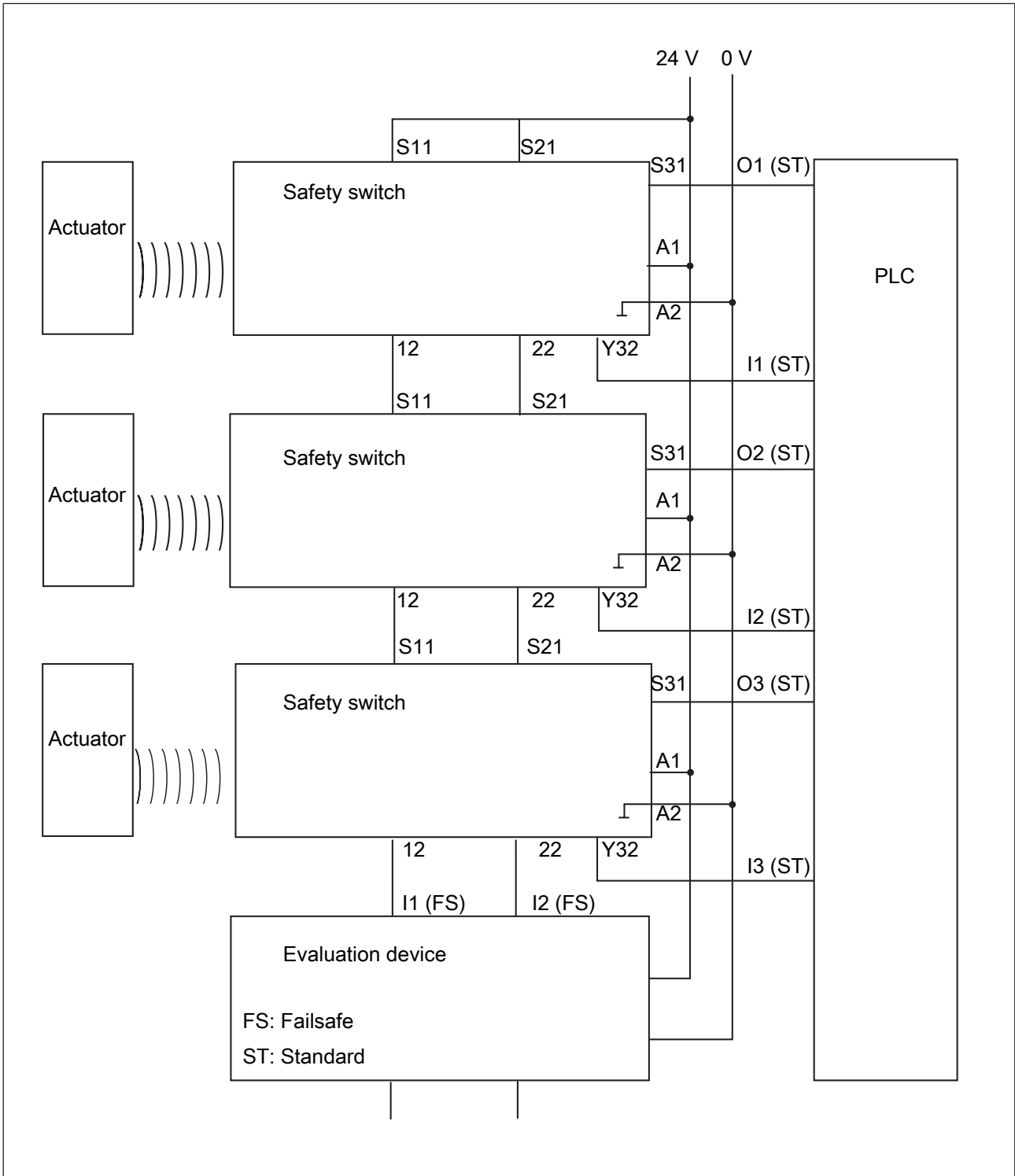

**CAUTION!****Extension of delay-on de-energisation**

When several (n) devices are connected in series, the delay-on de-energisation time adds with the number of interconnected safety switches. The may. delay-on de-energisation is composed of

- max. delay-on de-energisation actuator
- + (n-1) x max. delay-on de-energisation of the inputs
- + delay-on de-energisation of the evaluation device

**CAUTION!**

When several units are connected in series, the required current adds with the number of interconnected safety switches.

Function test when safety channels are connected in series

Before commissioning and after each change, check that the safety function is guaranteed when the gates are opened. To do this, open each gate individually and check the status at the inputs on the evaluation device:

- ▶ Close all the gates.
 - There must be high signals at the inputs on the evaluation device (e.g. S11, S21 or I1, I2).
- ▶ Open one gate; the other gates remain closed.
 - There must be low signals at the inputs on the evaluation device (e.g. S11, S21 or I1, I2).
- ▶ Close the gate again.
 - High signals must return at the inputs on the evaluation device (e.g. S11, S21 or I1, I2).
- ▶ Repeat the test for each gate.
- ▶ If the input signals do not react as described above, check and rectify the wiring and carry out the test again.

The safety switch PSEN sl-1.0p 4.1/4.2 can be connected to Pilz evaluation devices, for example.

Suitable Pilz evaluation devices are, for example:

- ▶ PNOZelog for safety gate monitoring
- ▶ PNOZpower for safety gate monitoring
- ▶ PNOZsigma for safety gate monitoring
- ▶ PNOZ X for safety gate monitoring
- ▶ PNOZmulti for safety gate monitoring
Configure the safety switch in the PNOZmulti Configurator with switch type 3.
- ▶ PSS for safety gate monitoring with standard function block SB064, SB066 or FS_Safety Gate

The correct connection to the respective evaluation device is described in the operating manual for the evaluation device. Make sure that the connection is made in accordance with the specifications in the operating manual for the selected evaluation device.

The connections to two evaluation devices are shown on the following pages, by way of example:

- ▶ PNOZ s3 and
- ▶ PNOZmulti

Connection example PNOZ s3

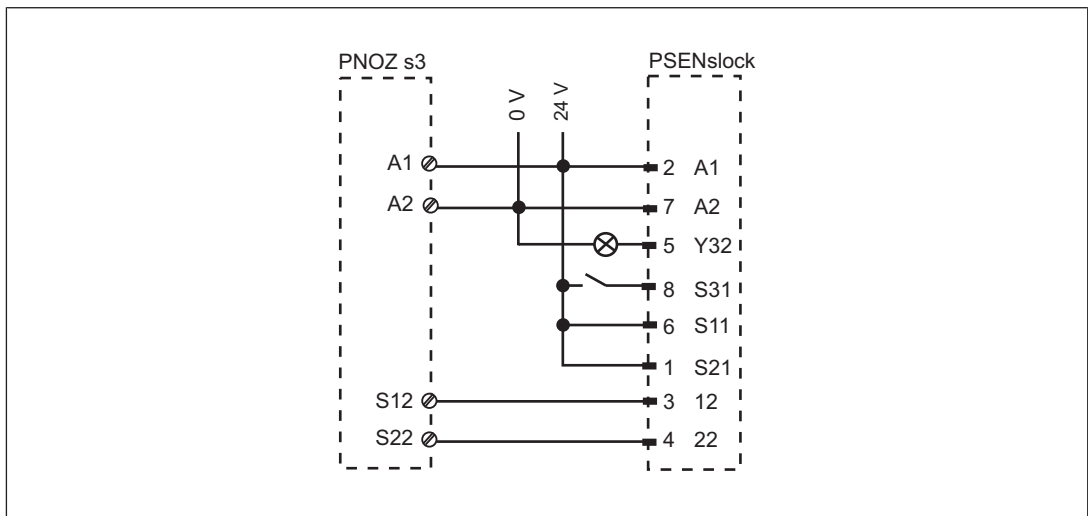

Connection example PNOZmulti

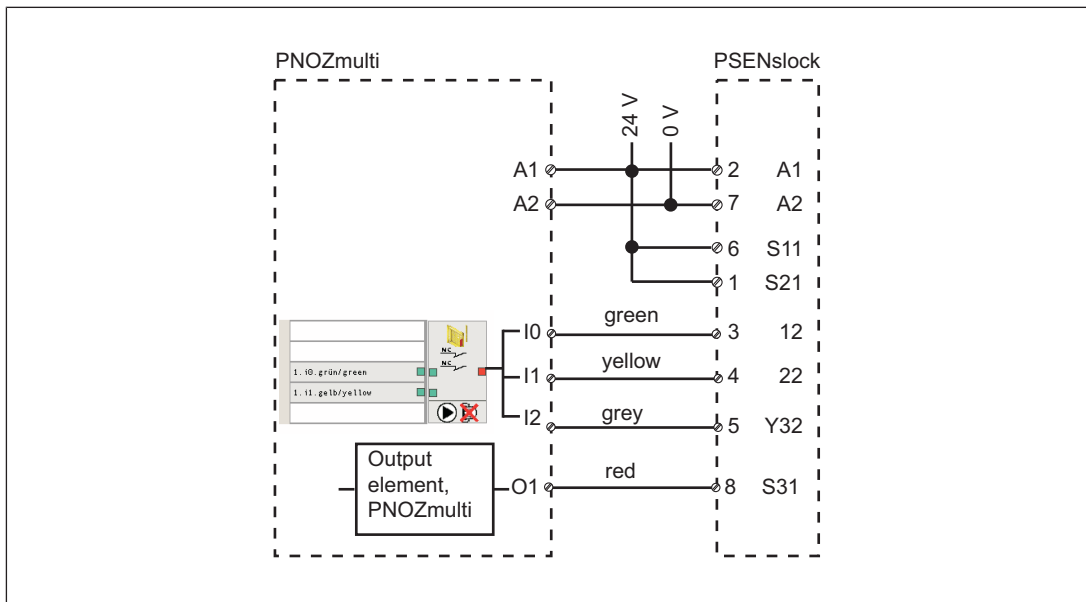

Legend:

I0	Input OSSD
I1	Input OSSD
I2	Signal input
O1	Lock/Unlock

Teaching in the actuator

PSEN sl-1.0p 4.1

Teaching in the actuator for the first time:

The first corresponding actuator to be detected by the safety switch (see Technical details: [System with normal actuator](#) [30], [System with free-moving actuator](#) [33]) is automatically taught in as soon as it is brought into the response range.

To teach in a new actuator:

- ▶ The actuator that is to be taught in must be brought into the safety switch's response range as the only transponder. As soon as the actuator is detected, the "Safety Gate" LED switches to a yellow flashing light.
- ▶ After a waiting period of 20 s has elapsed, the "Safety Gate" LED switches to quick yellow flashes. Trigger a system reset in the next 120 s by interrupting the power supply.
- ▶ When the device is switched back on, the learning procedure is complete and the number of permitted additional learning procedures is reduced by 1.
- ▶ A maximum of 8 learning procedures are possible.



NOTICE

The actuator must not be removed during the learning procedure.



INFORMATION

This actuator cannot be retaught on the same safety switch.

PSEN sl-1.0p 4.2

The first corresponding actuator to be detected by the safety switch (see Technical details: [System with normal actuator](#) [30], [System with free-moving actuator](#) [33], under mechanical data) is automatically taught in as soon as it is brought into the response range.



NOTICE

No other actuator may be taught in once this actuator has been taught.

Installation

- ▶ The safety gate system can be installed on left or right-hinged swing gates or on sliding gates.



WARNING!

Potential loss of safety function due to gross manipulation

Depending on the application, serious injury or death may result.

Use appropriate installation measures to prevent

- The wiring being modified.
- A short circuit being generated on the connector.
- The possibility of using a second actuator to open the safety gate.



CAUTION!

The unit's properties may be affected if installed in an environment containing electrically or magnetically conductive material. Please check the operating distances and the assured release distance.

- ▶ Safety switches and actuators must be positioned so that they are secured against a change of position.
- ▶ Also note the max. angular offset (see Technical details: [System with normal actuator](#) [30], [System with free-moving actuator](#) [33]).
- ▶ The access to the safety switch and actuator has to be possible for maintenance and checking the correct operation.
- ▶ Use reliable fastening elements. A tool is to be required to loosen the fastening elements.
- ▶ Prevent self-loosening of the fastening elements of safety switch and actuator.
- ▶ The fastening of safety switch and actuator has to be sufficiently stable to ensure the proper operation of the safety switch and the actuator.
- ▶ Prevent the safety switch and actuator being exposed to heavy shock or vibration.
- ▶ Circumvention of the safety switch in a reasonably foreseeable manner must be prevented.
- ▶ Installation measures in accordance with EN ISO 14119
 - Use permanently secured safety screws with a flat head to attach the safety switch and the actuator (e.g. cheese-head or pan head screws) or rivets.
- ▶ Alignment errors of the guard must not adversely affect the safety function of the guard.



INFORMATION

Mounting brackets are available as [accessories](#) [39].

Note regarding the free-moving actuator PSEN sl-1.0fm

The actuators PSEN sl-1.0fm are fitted with a movable metal plate. For this reason, a recess must be provided in the mounting surface for the screw connection.

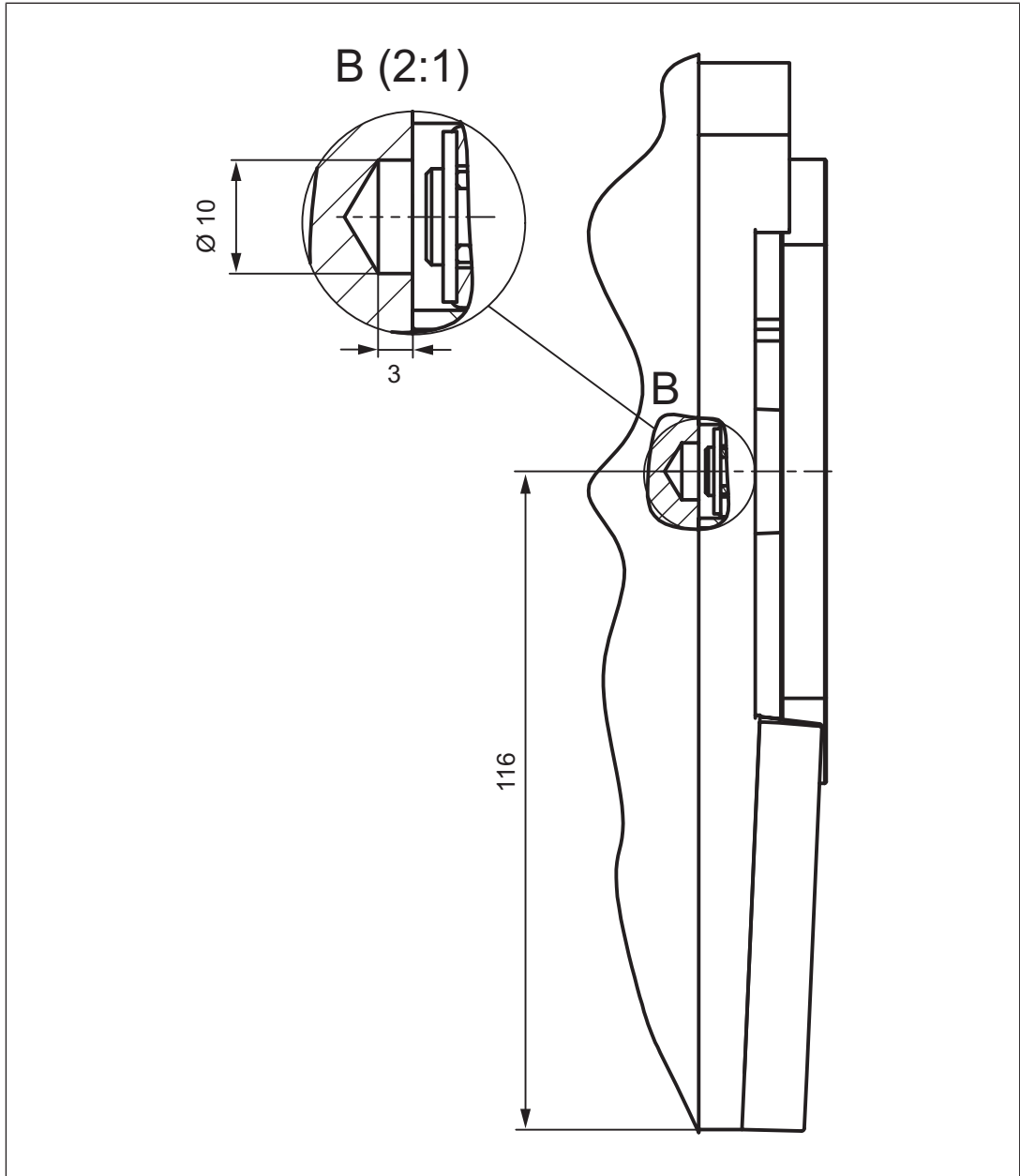

WARNING!

Risk of death and serious injury by reaching into the danger zone!

The actuators enable a warped gate to be closed. A gap may occur on the gate as a result. Make sure that the gap remains small enough to exclude the possibility of reaching into the danger zone.

Installing on a swing gate

Align the actuator flush with the edge of the gate at the height required and tighten the screws



Close gate.

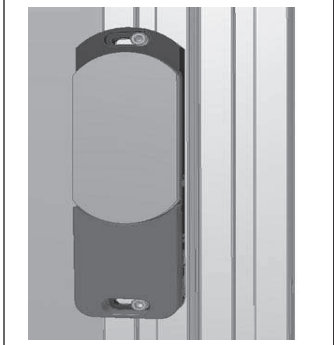

Align the mounting bracket flush with the safety switch and tighten the screws.



Align the safety switch and mounting bracket with the actuator and tighten the screws.

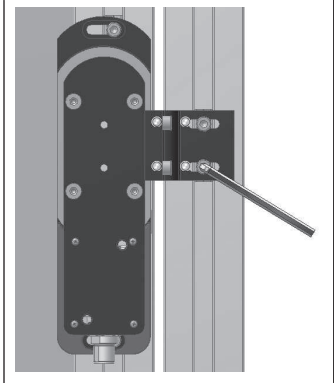

Installing on a sliding gate

Align the actuator mounting bracket flush with the sliding gate and tighten the screws.

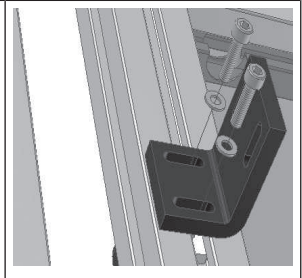

Install the actuator at the height required.

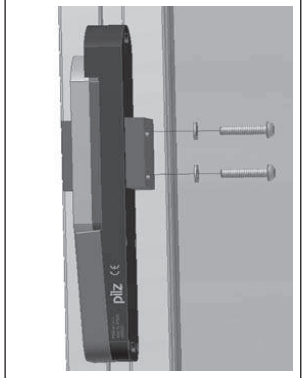

Align the safety switch mounting bracket flush with the frame and fasten with screws.
(Important: do not tighten the screws)

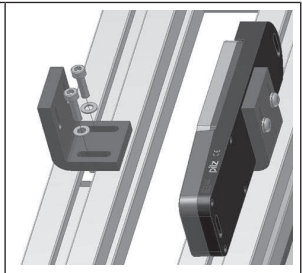

Fix safety switch upright with a **screw** (a), close gate.

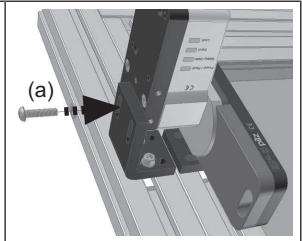

Align mounting brackets, press firmly together and tighten screw (b).

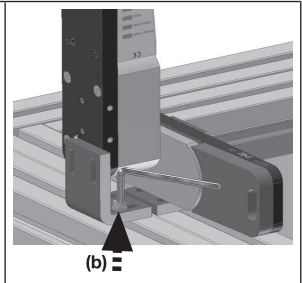

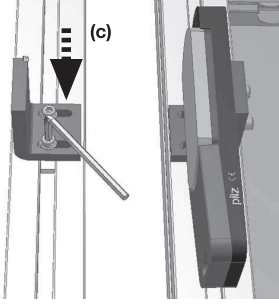
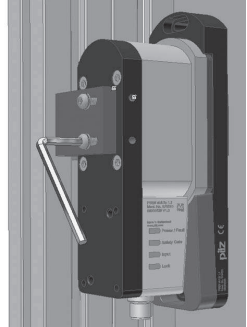
<p>Remove the safety switch and tighten screw (c).</p>	
<p>Align the safety switch to the actuator and tighten the screws.</p>	

Adjustment

- ▶ The stated operating distances (see Technical details: [System with normal actuator](#) [📖 30], [System with free-moving actuator](#) [📖 33]) only apply when the safety switch and actuator are installed facing each other in parallel. Operating distances may deviate if other arrangements are used.
- ▶ Note the maximum permitted lateral and vertical offset (see [Lateral and vertical offset](#) [📖 12]).

Operation



NOTICE

The safety functions should be checked after initial commissioning and each time the plant/machine is changed. The safety functions may only be checked by qualified personnel.



CAUTION!

Contaminated surfaces can reduce the holding force of the electromagnet.

Make sure that the contact surfaces are clean.

Status indicators:

- ▶ "Power/Fault" LED lights up green: The unit is ready for operation
- ▶ "Safety Gate" LED lights up yellow: Actuator is within the response range
- ▶ "Lock" LED lights up green: Magnetic guard locking device active and signal output Y32 is high
- ▶ "Input" LED lights up yellow: There is a HIGH signal at the inputs

Error display through periodic flashing:

- ▶ "Input" LED lights up yellow: the signal switches from high to low at one input, while a high signal remains on the other input (**partial operation**).
Remedy: Open both channels of the input circuit.
- ▶ "Power/Fault" LED lights up red: Error message
Flashing codes for fault diagnostics are output to the "Safety Gate" or "Input" LED (see Error display through flashing codes).
Remedy: Rectify fault and interrupt power supply.
- ▶ "Lock" LED lights up red: Guard locking request is present, but guard locking has not taken place within 600 ms or the safety gate was opened by force.
This behaviour occurs, for example, when the safety gate is open or the actuator is not within the response range (even temporarily) or the holding force is too low.
Remedy: Rectify the cause (e.g. close safety gate), switch off S31 and then switch it back on again after at least 500 ms.

Please note the different times for

- ▶ The switch-on delay after UB is applied.

Error display through flashing codes

The "Safety Gate" and "Input" LEDs send flash signals; an error code can be established from the number and sequence. The "Power/Fault" LED illuminates red.

Each error code is indicated by three short flashes of the "Input" or "Safety Gate" LED. After a longer pause, the LED will then flash at one second intervals. The number of LED flashes corresponds to a digit in the error code. The error code can consist of up to 3 digits. The digits are separated by a longer period without flashing. The entire sequence is constantly repeated.

Number of flashes	1 2 3 4 5 6 7 8 9 10 11 12 13 14 15 16
Decimal error code	1 2 3 4 5 6 7 8 9 10 11 12 13 14 15 0

Example:

Error code 1,4,1:

Flash frequency of the "Safety Gate" or "Input" LED

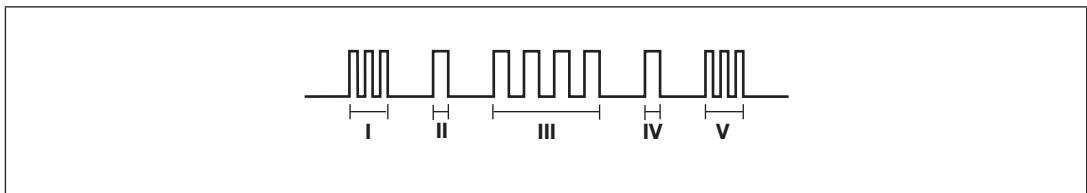

Meaning of flash frequency:

	Flash frequency	Meaning
I	3 times, short	Code for error message
II	Once, for one second each	Code for 1st digit
III	4 times, for one second each	Code for 2nd digit
IV	Once, for one second each	Code for 3rd digit
V	3 times, short	Code for error message repeated

Table of error codes

Error code Decimal	Number of flashes	Description	Remedy
1,4,1	3x short – 1x long – 4x long – 1x long – 3x short	Wiring errors at the inputs or outputs	Check the wiring of the inputs and outputs and rectify wiring errors
1,12	3x short – 1x long – 12x long – 3x short	Wiring error output 12	Check wiring output 12 and rectify wiring error
1,6,3	3x short – 1x long – 6x long – 3x long – 3x short	Wiring error output 12	Check wiring output 12 and rectify wiring error
1,13	3x short – 1x long – 12x long – 3x short	Wiring error output 22	Check wiring output 22 and rectify wiring error
1,6,4	3x short – 1x long – 6x long – 4x long – 3x short	Wiring error output 22	Check wiring output 22 and rectify wiring error
14	3x short – 14x long – 3x short	Wiring error output terminal 12 or capacitive load is too high (cable is too long)	Check wiring output 12 and rectify wiring error Check cable length and shorten it, if necessary (see max. cable length)
15	3x short – 15x long – 3x short	Wiring error output terminal 22 or capacitive load is too high (cable is too long)	Check wiring output 22 and rectify wiring error Check cable length and shorten it, if necessary (see max. cable length)

Other flashing codes signal an internal error. Remedy: Change device.

Dimensions in mm

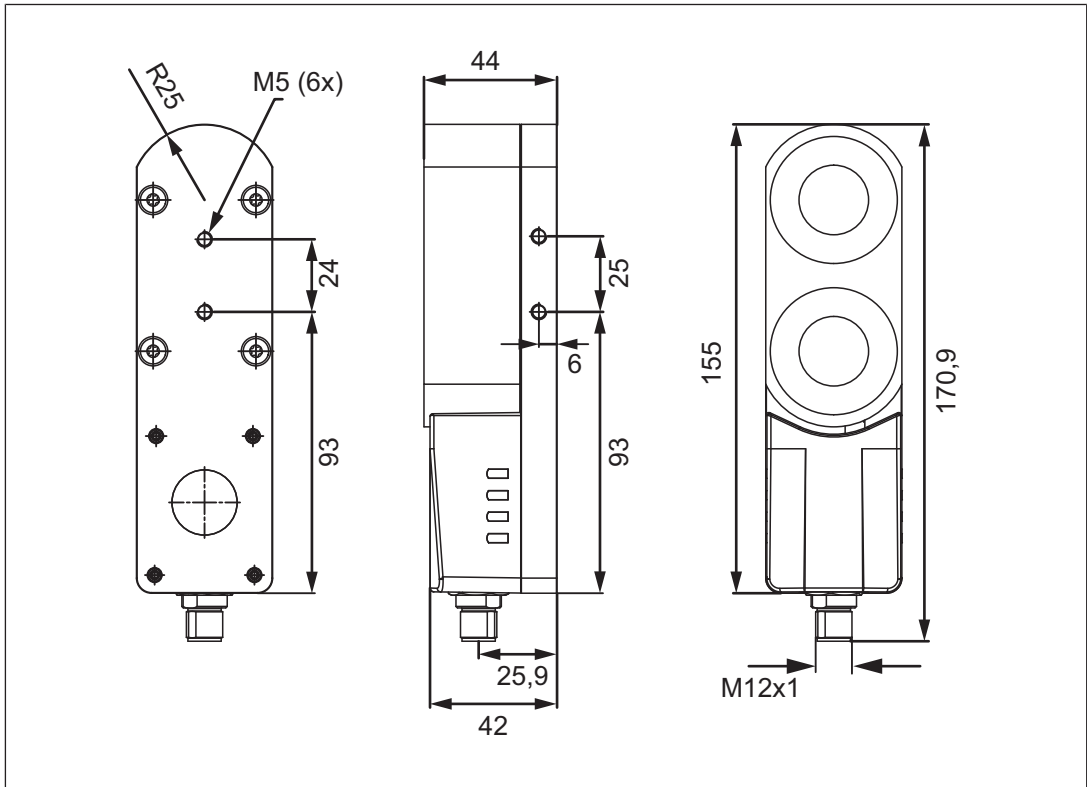

Fig.: Safety switch and locking magnet

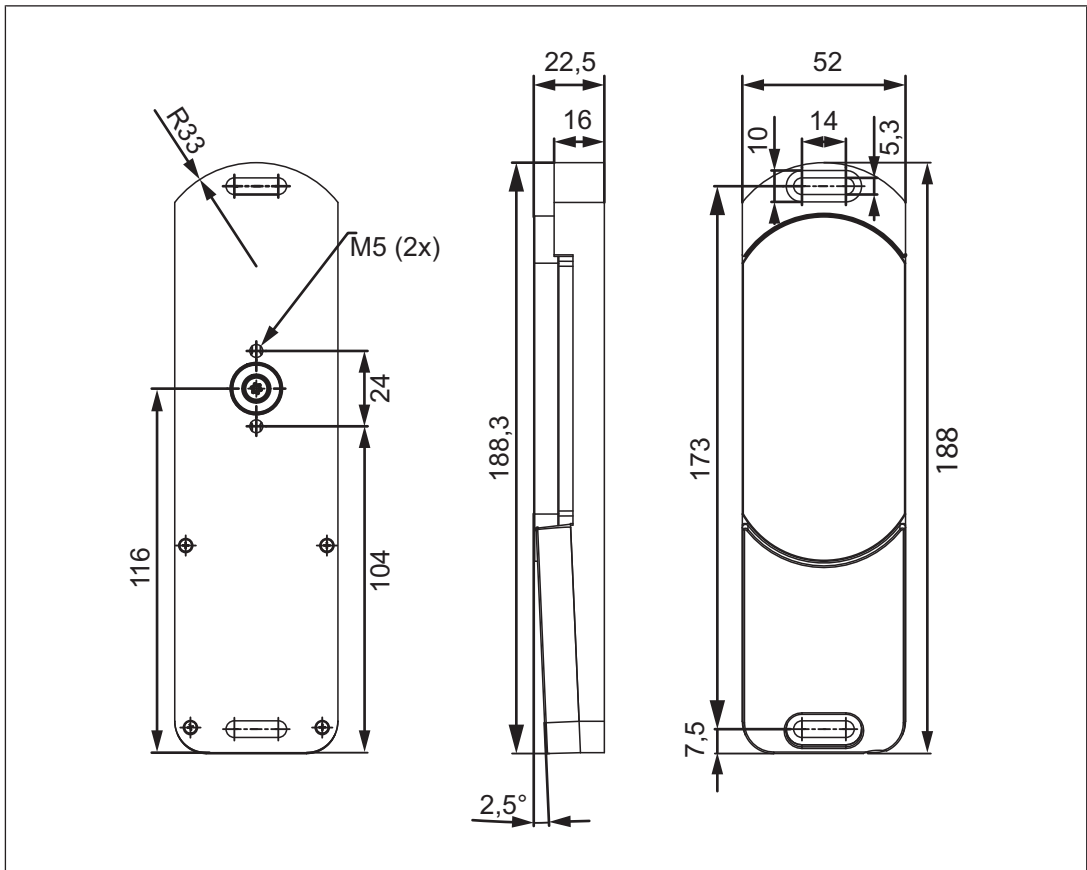

Fig.: Actuator

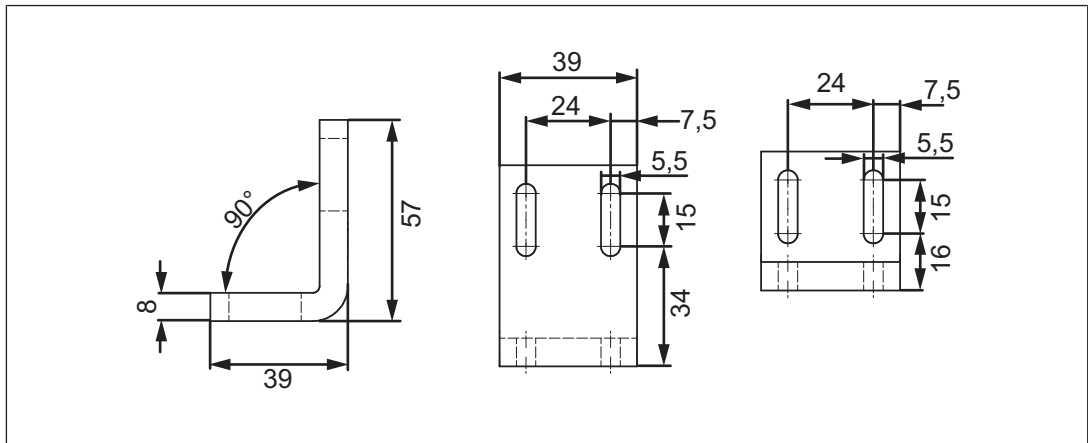

Fig.: Mounting bracket for sliding gate (see [Accessories](#) [39])

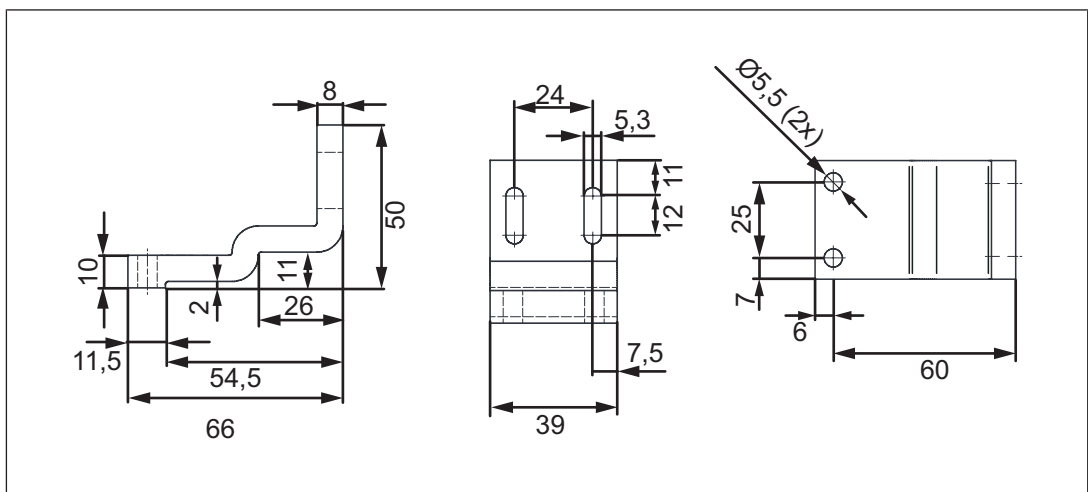

Fig.: Mounting bracket for swing gate (see [Accessories](#) [39])

Technical Details Order No. 570671-570672

General	570671	570672
Certifications	CE, EAC, FCC, IC, TÜV, UKCA, cULus Listed	CE, EAC, FCC, IC, TÜV, UKCA, cULus Listed
Sensor's mode of operation	Transponder	Transponder
Coding level in accordance with EN ISO 14119	High	High
Design in accordance with EN ISO 14119	4	4
Classification in accordance with EN 60947-5-3	PDDB	PDDB
Pilz coding type	fully coded	uniquely coded
Transponder	570671	570672
Frequency band	122 kHz - 128 kHz	122 kHz - 128 kHz
Max. transmitter output	15 mW	15 mW
Electrical data	570671	570672
Supply voltage		
Voltage	24 V	24 V
Kind	DC	DC
Voltage tolerance	-15 %/+10 %	-15 %/+10 %
Output of external power supply (DC)	7,2 W	7,2 W
Max. inrush current at UB	0,6 A	0,6 A
Max. switching frequency	1 Hz	1 Hz
Max. cable capacitance at the safety outputs		
No-load, PNOZ with relay contacts	40 nF	40 nF
PNOZmulti, PNOZelog, PSS	70 nF	70 nF
No-load current	40 mA	40 mA
Inputs	570671	570672
Number	3	3
Voltage at inputs	24 V DC	24 V DC
Input current range	5 mA	5 mA
Semiconductor outputs	570671	570672
Number of OSSD safety outputs	2	2
Signal outputs	1	1
Switching current per output	500 mA	500 mA
Breaking capacity per output	12 W	12 W
Short circuit-proof	yes	yes
Residual current at outputs	250 µA	250 µA
Voltage drop at OSSDs	1,5 V	1,5 V
Conditional rated short circuit current	100 A	100 A
Lowest operating current	0 mA	0 mA

Semiconductor outputs	570671	570672
Utilisation category in accordance with EN 60947-1	DC-12	DC-12
Times	570671	570672
Test pulse duration, safety outputs	450 µs	450 µs
Switch-on delay		
after UB is applied	1,6 s	1,6 s
Inputs typ.	20 ms	20 ms
Inputs max.	35 ms	35 ms
Actuator typ.	500 ms	500 ms
Delay-on de-energisation		
Inputs typ.	20 ms	20 ms
Inputs max.	35 ms	35 ms
Actuator typ.	25 ms	25 ms
Actuator max.	260 ms	260 ms
Risk time in accordance with EN 60947-5-3	260 ms	260 ms
Supply interruption before de-energisation	15 ms	15 ms
Simultaneity, channel 1 and 2 max.	∞	∞
Environmental data	570671	570672
Temperature of metal surface at ambient temperature: 25 °C	35 °C	35 °C
Ambient temperature		
In accordance with the standard	EN 60068-2-14	EN 60068-2-14
Temperature range	-25 - 55 °C	-25 - 55 °C
Storage temperature		
In accordance with the standard	EN 60068-2-1/-2	EN 60068-2-1/-2
Temperature range	-25 - 70 °C	-25 - 70 °C
Climatic suitability		
In accordance with the standard	EN 60068-2-78	EN 60068-2-78
Humidity	93 % r. h. at 40 °C	93 % r. h. at 40 °C
EMC	EN 55011: class A, EN 60947-5-3, EN 62061	EN 55011: class A, EN 60947-5-3, EN 62061
Vibration		
In accordance with the standard	EN 60947-5-2	EN 60947-5-2
Frequency	10 - 55 Hz	10 - 55 Hz
Amplitude	1 mm	1 mm
Shock stress		
In accordance with the standard	EN 60068-2-27	EN 60068-2-27
Number of shocks	3	3
Acceleration	30g	30g
Duration	11 ms	11 ms
In accordance with the standard	EN 60068-2-29	EN 60068-2-29
Number of shocks	500	500
Acceleration	10g	10g
Duration	16 ms	16 ms

Environmental data	570671	570672
Airgap creepage		
Overvoltage category	III	III
Pollution degree	3	3
Rated insulation voltage	75 V	75 V
Rated impulse withstand voltage	1 kV	1 kV
Protection type		
Housing	IP67	IP67
Operating distances	570671	570672
Assured operating distance Sao	1 mm	1 mm
Typical operating distance So	2 mm	2 mm
Assured release distance Sar	15 mm	15 mm
Repetition accuracy switching distances	40 %	40 %
Typ. Hysteresis	0,7 mm	0,7 mm
Mechanical data	570671	570672
Holding force FZh in accordance with ISO 14119	850 N	850 N
Magnetic holding force on	1.000 N	1.000 N
Magnetic holding force off	20 N	20 N
Max. vertical offset	5 mm	5 mm
Max. lateral offset	3 mm	3 mm
Max. angular offset	2,5 deg	2,5 deg
Actuator 1	PSEN sl-1.0 2.1	PSEN sl-1.0 2.1
Min. distance between safety switches	30 mm	30 mm
Sensor flush installation in accordance with EN 60947-5-2	yes, follow installation guidelines	yes, follow installation guidelines
Connection type	M12, 8-pin male connector	M12, 8-pin male connector
Cable	LiYY 8 x 0.25 mm2	LiYY 8 x 0.25 mm2
Material		
Top	PBT	PBT
Anchor plate	Nickel-plated steel	Nickel-plated steel
Base plate	Anticorodal, hard anodised	Anticorodal, hard anodised
Actuator	Anticorodal, hard anodised	Anticorodal, hard anodised
Max. torque setting for fixing screws	3 Nm	3 Nm
Dimensions		
Height	172 mm	172 mm
Width	45 mm	45 mm
Depth	44 mm	44 mm
Actuator dimensions		
Height	188 mm	188 mm
Width	52 mm	52 mm
Depth	22 mm	22 mm
Weight of safety switch	1.120 g	1.120 g

Mechanical data	570671	570672
Weight of actuator	600 g	600 g
Weight	1.720 g	1.720 g

Where standards are updated, the 2015-04 latest editions shall apply.

Technical Details Order No. 570674-570675

General	570674	570675
Certifications	CE, EAC, FCC, IC, TÜV, UKCA, cULus Listed	CE, EAC, FCC, IC, TÜV, UKCA, cULus Listed
Sensor's mode of operation	Transponder	Transponder
Coding level in accordance with EN ISO 14119	High	High
Design in accordance with EN ISO 14119	4	4
Classification in accordance with EN 60947-5-3	PDDB	PDDB
Pilz coding type	fully coded	uniquely coded
Transponder	570674	570675
Frequency band	122 kHz - 128 kHz	122 kHz - 128 kHz
Max. transmitter output	15 mW	15 mW
Electrical data	570674	570675
Supply voltage		
Voltage	24 V	24 V
Kind	DC	DC
Voltage tolerance	-15 %/+10 %	-15 %/+10 %
Output of external power supply (DC)	7,2 W	7,2 W
Max. inrush current at UB	0,6 A	0,6 A
Max. switching frequency	1 Hz	1 Hz
Max. cable capacitance at the safety outputs		
No-load, PNOZ with relay contacts	40 nF	40 nF
PNOZmulti, PNOZelog, PSS	70 nF	70 nF
No-load current	40 mA	40 mA
Inputs	570674	570675
Number	3	3
Voltage at inputs	24 V DC	24 V DC
Input current range	5 mA	5 mA
Semiconductor outputs	570674	570675
Number of OSSD safety outputs	2	2
Signal outputs	1	1
Switching current per output	500 mA	500 mA
Breaking capacity per output	12 W	12 W
Short circuit-proof	yes	yes

Semiconductor outputs		
	570674	570675
Residual current at outputs	250 µA	250 µA
Voltage drop at OSSDs	1,5 V	1,5 V
Conditional rated short circuit current	100 A	100 A
Lowest operating current	0 mA	0 mA
Utilisation category in accordance with EN 60947-1	DC-12	DC-12
Times		
	570674	570675
Test pulse duration, safety outputs	450 µs	450 µs
Switch-on delay		
after UB is applied	1,6 s	1,6 s
Inputs typ.	20 ms	20 ms
Inputs max.	35 ms	35 ms
Actuator typ.	500 ms	500 ms
Delay-on de-energisation		
Inputs typ.	20 ms	20 ms
Inputs max.	35 ms	35 ms
Actuator typ.	25 ms	25 ms
Actuator max.	260 ms	260 ms
Risk time in accordance with EN 60947-5-3	260 ms	260 ms
Supply interruption before de-energisation	15 ms	15 ms
Simultaneity, channel 1 and 2 max.	∞	∞
Environmental data		
	570674	570675
Temperature of metal surface at ambient temperature: 25 °C	35 °C	35 °C
Ambient temperature		
In accordance with the standard	EN 60068-2-14	EN 60068-2-14
Temperature range	-25 - 55 °C	-25 - 55 °C
Storage temperature		
In accordance with the standard	EN 60068-2-1/-2	EN 60068-2-1/-2
Temperature range	-25 - 70 °C	-25 - 70 °C
Climatic suitability		
In accordance with the standard	EN 60068-2-78	EN 60068-2-78
Humidity	93 % r. h. at 40 °C	93 % r. h. at 40 °C
EMC	EN 55011: class A, EN 60947-5-3, EN 62061	EN 55011: class A, EN 60947-5-3, EN 62061
Vibration		
In accordance with the standard	EN 60947-5-2	EN 60947-5-2
Frequency	10 - 55 Hz	10 - 55 Hz
Amplitude	1 mm	1 mm

Environmental data	570674	570675
Shock stress		
In accordance with the standard	EN 60068-2-27	EN 60068-2-27
Number of shocks	3	3
Acceleration	30g	30g
Duration	11 ms	11 ms
In accordance with the standard	EN 60068-2-29	EN 60068-2-29
Number of shocks	500	500
Acceleration	10g	10g
Duration	16 ms	16 ms
Airgap creepage		
Overvoltage category	III	III
Pollution degree	3	3
Rated insulation voltage	75 V	75 V
Rated impulse withstand voltage	1 kV	1 kV
Protection type		
Housing	IP67	IP67
Operating distances	570674	570675
Assured operating distance Sao	1 mm	1 mm
Typical operating distance So	2 mm	2 mm
Assured release distance Sar	15 mm	15 mm
Repetition accuracy switching distances	40 %	40 %
Typ. Hysteresis	0,7 mm	0,7 mm
Mechanical data	570674	570675
Holding force FZh in accordance with ISO 14119	850 N	850 N
Magnetic holding force on	1.000 N	1.000 N
Magnetic holding force off	20 N	20 N
Max. vertical offset	5 mm	5 mm
Max. lateral offset	3 mm	3 mm
Max. angular offset	2,5 deg	2,5 deg
Actuator 1	PSEN sl-1.0fm 2.1	PSEN sl-1.0fm 2.1
Min. distance between safety switches	30 mm	30 mm
Sensor flush installation in accordance with EN 60947-5-2	yes, follow installation guidelines	yes, follow installation guidelines
Connection type	M12, 8-pin male connector	M12, 8-pin male connector
Cable	LiYY 8 x 0.25 mm2	LiYY 8 x 0.25 mm2
Material		
Top	PBT	PBT
Anchor plate	Nickel-plated steel	Nickel-plated steel
Base plate	Anticorodal, hard anodised	Anticorodal, hard anodised
Actuator	Anticorodal, hard anodised	Anticorodal, hard anodised
Max. torque setting for fixing screws	3 Nm	3 Nm

Mechanical data	570674	570675
Dimensions		
Height	172 mm	172 mm
Width	45 mm	45 mm
Depth	44 mm	44 mm
Actuator dimensions		
Height	188 mm	188 mm
Width	52 mm	52 mm
Depth	22 mm	22 mm
Weight of safety switch	1.120 g	1.120 g
Weight of actuator	590 g	590 g
Weight	1.710 g	1.710 g

Where standards are undated, the 2015-04 latest editions shall apply.

Supplementary data

Radio approval

USA/Canada

FC FCC ID: VT8-PSENSLP
IC: 7482A-PSENSLP

FCC/IC-Requirements:
 This product complies with Part 15 of the FCC Rules and with Industry Canada licence-exempt RSS standards.
 Operation is subject to the following two conditions:
 1) this product may not cause harmful interference, and
 2) this product must accept any interference received, including interference that may cause undesired operation.

Changes or modifications made to this product not expressly approved by Pilz may void the FCC authorization to operate this equipment.

NOTE: This equipment has been tested and found to comply with the limits for a Class A digital device, pursuant to Part 15 of the FCC Rules. These limits are designed to provide reasonable protection against harmful interference when the equipment is operated in a commercial environment. This equipment generates, uses, and can radiate radio frequency energy and, if not installed and used in accordance with the instruction manual, may cause harmful interference to radio communications. Operation of this equipment in a residential area is likely to cause harmful interference in which case the user will be required to correct the interference at his own expense.

Le présent produit est conforme aux CNR d'Industrie Canada applicables aux appareils radio exempts de licence. L'exploitation est autorisée aux deux conditions suivantes:
 (1) le produit ne doit pas produire de brouillage, et
 (2) l'utilisateur de le produit doit accepter tout brouillage radioélectrique subi, même si le brouillage est susceptible d'en compromettre le fonctionnement.

Safety characteristic data



NOTICE

You must comply with the safety characteristic data in order to achieve the required safety level for your plant/machine.

Operating mode	EN ISO 13849-1: 2015 PL	EN ISO 13849-1: 2015 Category	EN IEC 62061 SIL CL/ maximum SIL	EN IEC 62061 PFH _D [1/h]	EN/IEC 61511 SIL	EN/IEC 61511 PFD	EN ISO 13849-1: 2015 T _M [year]
2-ch. OSSD	PL e	Cat. 4	SIL CL 3	3,29E-09	SIL 3	1,72E-04	20

Explanatory notes for the safety-related characteristic data:

- ▶ Safety characteristic data in accordance with EN IEC 62061 and EN/IEC 61511 was calculated based on EN/IEC 61508.
- ▶ T_M is the maximum mission time in accordance with EN ISO 13849-1. The value also applies as the retest interval in accordance with EN/IEC 61508-6 and EN/IEC 61511 and as the proof test interval and mission time in accordance with EN IEC 62061.

All the units used within a safety function must be considered when calculating the safety characteristic data.



INFORMATION

A safety function's SIL/PL values are **not** identical to the SIL/PL values of the units that are used and may be different. We recommend that you use the PASCAL software tool to calculate the safety function's SIL/PL values.

Classification according to ZVEI, CB24I

The following tables describe the classes and specific values of the product interface and the classes of interfaces compatible with it. The classification is described in the ZVEI position paper "Classification of Binary 24 V Interfaces - Functional Safety aspects covered by dynamic testing".

Input

Interfaces

Drain

Interface	Sensor
Class	C2

Source

Class	C2, C3
-------	--------

Drain parameters

Max. test pulse duration	0,5 ms
Min. test pulse interval	2 ms
Min. input resistance	4,4 kOhm
Max. capacitive load	1 nF

Single-pole output

Interfaces

Source

Interface	Sensor
Class	C2

Drain

Interface	Evaluation device
Class	C1, C2

Source parameters

Max. test pulse duration	500 μ s
Max. rated current	0,1 A
Max. capacitive load	0,07 μ F

Order reference

Safety gate system

Product type	Features	Connection type	Order no.
PSEN sl-1.0p 4.1 / PSEN sl-1.0 1 unit	Safety gate system, fully coded	M12, 8-pin connector	570671
PSEN sl-1.0p 4.2 / PSEN sl-1.0 1 unit	Safety gate system, uniquely coded	M12, 8-pin connector	570672
PSEN sl-1.0p 4.1 / PSEN sl-1.0fm 1 unit	Safety gate system, fully coded, with free-moving actuator	M12, 8-pin connector	570674
PSEN sl-1.0p 4.2 / PSEN sl 1.0fm 1 unit	Safety gate system, uniquely coded, with free-moving actuator	M12, 8-pin connector	570675

Accessories

Product type	Features	Order no.
PSEN sl bracket swing door	Mounting bracket for swing gates and folding gates	570550
PSEN sl bracket sliding door	Mounting bracket for sliding gates	570551
PSEN sl restart interlock	Add-on module for the safety gate systems PSENslock and PSENsl2	570552

EC declaration of conformity

This product/these products meet the requirements of the directive 2006/42/EC for machinery of the European Parliament and of the Council. The complete EC Declaration of Conformity is available on the Internet at www.pilz.com/downloads.

Authorised representative: Norbert Fröhlich, Pilz GmbH & Co. KG, Felix-Wankel-Str. 2, 73760 Ostfildern, Germany

UKCA-Declaration of Conformity

This product(s) complies with following UK legislation: Supply of Machinery (Safety) Regulation 2008.

The complete UKCA Declaration of Conformity is available on the Internet at www.pilz.com/downloads.

Representative: Pilz Automation Technology, Pilz House, Little Colliers Field, Corby, Northamptonshire, NN18 8TJ United Kingdom, eMail: mail@pilz.co.uk

Support

Technical support is available from Pilz round the clock.

Americas

Brazil

+55 11 97569-2804

Canada

+1 888 315 7459

Mexico

+52 55 5572 1300

USA (toll-free)

+1 877-PILZUSA (745-9872)

Asia

China

+86 21 60880878-216

Japan

+81 45 471-2281

South Korea

+82 31 778 3300

Australia and Oceania

Australia

+61 3 95600621

New Zealand

+64 9 6345350

Europe

Austria

+43 1 7986263-0

Belgium, Luxembourg

+32 9 3217570

France

+33 3 88104003

Germany

+49 711 3409-444

Ireland

+353 21 4804983

Italy, Malta

+39 0362 1826711

Scandinavia

+45 74436332

Spain

+34 938497433

Switzerland

+41 62 88979-32

The Netherlands

+31 347 320477

Turkey

+90 216 5775552

United Kingdom

+44 1536 462203

You can reach our international hotline on:

+49 711 3409-222

support@pilz.com

Pilz develops environmentally-friendly products using ecological materials and energy-saving technologies. Offices and production facilities are ecologically designed, environmentally-aware and energy-saving. So Pilz offers sustainability, plus the security of using energy-efficient products and environmentally-friendly solutions.



We are represented internationally. Please refer to our homepage www.pilz.com for further details or contact our headquarters.

Headquarters: Pilz GmbH & Co. KG, Felix-Wankel-Straße 2, 73760 Ostfildern, Germany
Telephone: +49 711 3409-0, Telefax: +49 711 3409-133, E-Mail: info@pilz.com, Internet: www.pilz.com

PILZ
THE SPIRIT OF SAFETY

1003808-EN-04, 2022-11 Printed in Germany
© Pilz GmbH & Co. KG, 2019

CECE®, CHRE®, CMSE®, InduraNET p®, Leansafe®, Master of Safety®, Master of Security®, PAS4000®, PAScall®, PASconfig®, Pilz®, PTT®, PLID®, PMCPirimo®, PMCPiritego®, PMCTendo®, PMD®, PMJ®, PNOZ®, PRBM®, PRGM®, PRCM®, PRCM®, PRTM®, PSEN®, PSEN®, PSS®, PVS®, SafetyBUS p®, SafetyEYE®, SafetyNET p®, THE SPIRIT OF SAFETY® are registered and protected trademarks of Pilz GmbH & Co. KG in some countries. We would point out that product features may vary from the details stated in this document, depending on the status at the time of publication and the scope of the equipment. We accept no responsibility for the validity, accuracy and entirety of the text and graphics presented in this information. Please contact our Technical Support if you have any questions.