



Visualisation; Diagnostics

Easy to Configure

Programming IEC 61131-3

Rapid Installation

## PZE X4V8

# PILZ

THE SPIRIT OF SAFETY

► Safety relays

This document is a translation of the original document.

All rights to this documentation are reserved by Pilz GmbH & Co. KG. Copies may be made for internal purposes. Suggestions and comments for improving this documentation will be gratefully received.

Source code from third-party manufacturers or open source software has been used for some components. The relevant licence information is available on the Internet on the Pilz homepage.

Pilz®, PIT®, PMI®, PNOZ®, Primo®, PSEN®, PSS®, PVIS®, SafetyBUS p®, SafetyEYE®, SafetyNET p®, the spirit of safety® are registered and protected trademarks of Pilz GmbH & Co. KG in some countries.



SD means Secure Digital

<b>Introduction</b>	<b>4</b>
Validity of documentation	4
Using the documentation	4
Definition of symbols	4
<b>Safety</b>	<b>5</b>
Intended use	5
Safety regulations	5
Safety assessment	5
Use of qualified personnel	5
Warranty and liability	6
Disposal	6
For your safety	6
<b>Unit features</b>	<b>7</b>
<b>Safety features</b>	<b>7</b>
<b>Block diagram/terminal configuration</b>	<b>7</b>
<b>Function description</b>	<b>8</b>
<b>Installation</b>	<b>8</b>
<b>Wiring</b>	<b>8</b>
<b>Preparing for operation</b>	<b>9</b>
<b>Operation</b>	<b>10</b>
Status indicators	11
<b>Faults – Interference</b>	<b>11</b>
<b>Dimensions in mm</b>	<b>11</b>
<b>Technical details</b>	<b>12</b>
Safety characteristic data	14
<b>Supplementary data</b>	<b>15</b>
Service life graph	15
<b>Order reference</b>	<b>16</b>
<b>EC declaration of conformity</b>	<b>16</b>

## Introduction

### Validity of documentation

This documentation is valid for the product PZE X4V8. It is valid until new documentation is published.

This operating manual explains the function and operation, describes the installation and provides guidelines on how to connect the product.

### Using the documentation

This document is intended for instruction. Only install and commission the product if you have read and understood this document. The document should be retained for future reference.

### Definition of symbols

Information that is particularly important is identified as follows:



#### **DANGER!**

This warning must be heeded! It warns of a hazardous situation that poses an immediate threat of serious injury and death and indicates preventive measures that can be taken.



#### **WARNING!**

This warning must be heeded! It warns of a hazardous situation that could lead to serious injury and death and indicates preventive measures that can be taken.



#### **CAUTION!**

This refers to a hazard that can lead to a less serious or minor injury plus material damage, and also provides information on preventive measures that can be taken.



#### **NOTICE**

This describes a situation in which the product or devices could be damaged and also provides information on preventive measures that can be taken. It also highlights areas within the text that are of particular importance.

**INFORMATION**

This gives advice on applications and provides information on special features.

**Safety****Intended use**

The contact expansion module PZE X4V8 meets the requirements of EN 60947-5-1, EN 60204-1 and VDE 0113-1. It is an expansion module for increasing the number of contacts available on a base unit. Base units are all safety relays with feedback loop.

The max. achievable safety level depends on the base unit. The expansion module may not exceed this. The safety-related characteristic values stated under [Safety-related characteristic data](#) [ 15] can only be achieved if the base unit also exhibits these values.

The following is deemed improper use in particular:

- ▶ Any component, technical or electrical modification to the product
- ▶ Use of the product outside the areas described in this manual
- ▶ Use of the product outside the technical details (see [Technical details](#) [ 12]).

**NOTICE**

EMC-compliant electrical installation

The product is designed for use in an industrial environment. The product may cause interference if installed in other environments. If installed in other environments, measures should be taken to comply with the applicable standards and directives for the respective installation site with regard to interference.

**Safety regulations****Safety assessment**

Before using a unit it is necessary to perform a safety assessment in accordance with the Machinery Directive.

Functional safety is guaranteed for the product as a single component. However, this does not guarantee the functional safety of the overall plant/machine. In order to achieve the required safety level for the overall plant/machine, define the safety requirements for the plant/machine and then define how these must be implemented from a technical and organisational standpoint.

**Use of qualified personnel**

The products may only be assembled, installed, programmed, commissioned, operated, maintained and decommissioned by competent persons.

A competent person is someone who, because of their training, experience and current professional activity, has the specialist knowledge required to test, assess and operate the work equipment, devices, systems, plant and machinery in accordance with the general standards and guidelines for safety technology.

It is the company's responsibility only to employ personnel who:

- ▶ Are familiar with the basic regulations concerning health and safety / accident prevention
- ▶ Have read and understood the information provided in this description under "Safety"
- ▶ And have a good knowledge of the generic and specialist standards applicable to the specific application.

### **Warranty and liability**

All claims to warranty and liability will be rendered invalid if

- ▶ The product was used contrary to the purpose for which it is intended
- ▶ Damage can be attributed to not having followed the guidelines in the manual
- ▶ Operating personnel are not suitably qualified
- ▶ Any type of modification has been made (e.g. exchanging components on the PCB boards, soldering work etc.).

### **Disposal**

- ▶ In safety-related applications, please comply with the mission time  $T_M$  in the safety-related characteristic data.
- ▶ When decommissioning, please comply with local regulations regarding the disposal of electronic devices (e.g. Electrical and Electronic Equipment Act).

### **For your safety**

The unit meets all the necessary conditions for safe operation. However, please note the following:

- ▶ Note for overvoltage category III: If voltages higher than low voltage (>50 VAC or >120 VDC) are present on the unit, connected control elements and sensors must have a rated insulation voltage of at least 250 V.

### Unit features

- ▶ Positive-guided relay outputs:
  - 4 safety contacts (N/O), delay-on de-energisation
- ▶ LED display for:
  - Switch status of the safety contacts
- ▶ Connection for feedback loop
- ▶ Operation: single-channel
- ▶ Selectable delay time

### Safety features

The unit meets the following safety requirements:

- ▶ The contact expander module expands an existing circuit. As the output relays are monitored via the base unit's feedback loop, the safety functions on the existing circuit are transferred to the contact expander module.
- ▶ The safety function remains effective in the case of a component failure.
- ▶ Earth fault in the feedback loop:  
Detected, depending on the base unit that is used.
- ▶ Earth fault in the input circuit:  
The output relays de-energise and the safety contacts open.

### Block diagram/terminal configuration

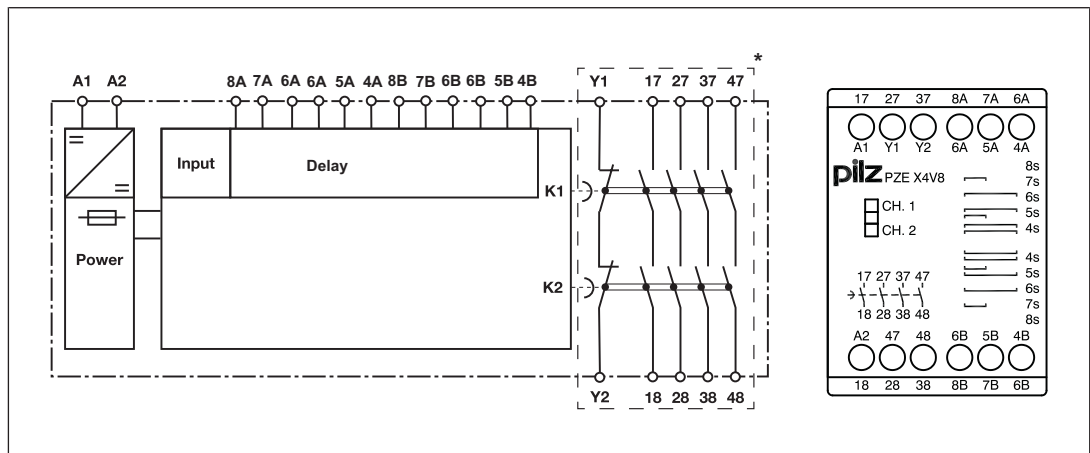

\*Insulation between the non-marked area and the relay contacts: Basic insulation (over-voltage category III), Protective separation (overvoltage category II)

## Function description

The contact expansion module PZE X4V8 is an add-on device with selectable delay-on de-energisation, and it is used to expand a safety circuit. The contact expansion module is driven by a base unit (e. g. emergency stop relay).

- ▶ Functional procedure once the input circuit is closed (e.g. safety contacts on the base unit are closed):
  - The supply voltage is present at input (A1) of the contact expansion module.
  - The safety contacts 17-18, 27-28, 37-38 and 47-48 close.
  - The LEDs "CH.1" and "CH.2" are lit.
- ▶ Functional procedure once the input circuit is opened (e.g. safety contacts on the base unit are opened):
  - The supply voltage is not present at input (A1) of the contact expansion module.
  - The LEDs "CH.1" and "CH.2" go out.
  - Safety contacts 17-18, 27-28, 37-38 and 47-48 are opened redundantly once the delay time has elapsed.



### NOTICE

At the latest the safety contacts open after the set delay time  $t_v + 50\%$  of the set value, even in the case of a component failure.

## Installation

- ▶ The unit should be installed in a control cabinet with a protection type of at least IP54.
- ▶ Use the notch on the rear of the unit to attach it to a DIN rail.
- ▶ Ensure the unit is mounted securely on a vertical DIN rail (35 mm) by using a fixing element (e.g. retaining bracket or an end angle).

## Wiring

Please note:

- ▶ Information given in the "[Technical details \[12\]](#)" must be followed.
- ▶ Outputs 17-18, 27-28, 37-38 and 47-48 are delay-on de-energisation safety contacts.
- ▶ To prevent contact welding, a fuse should be connected before the output contacts (see [Technical details \[12\]](#)).
- ▶ Calculation of the max. cable runs  $l_{max}$  in the input circuit:

$$l_{max} = \frac{R_{lmax}}{R_l / km}$$

$R_{lmax}$  = max. overall cable resistance (see [Technical details \[12\]](#))

$R_l / km$  = cable resistance/km

- ▶ Use copper wire that can withstand 60/75 °C.
- ▶ Sufficient fuse protection must be provided on all output contacts with capacitive and inductive loads.



- ▶ Do not switch low currents using contacts that have been used previously with high currents.
- ▶ The power supply must comply with the regulations for extra low voltages with protective electrical separation (SELV, PELV) in accordance with VDE 0100, Part 410.
- ▶ Ensure the wiring and EMC requirements of IEC 60204-1 are met.

**Preparing for operation**

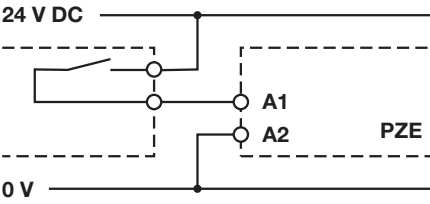
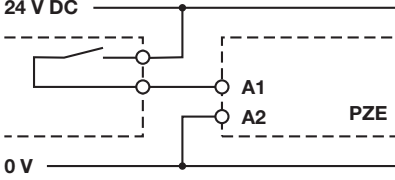
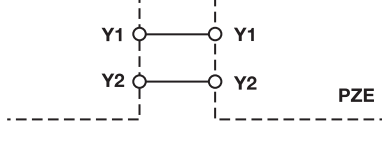
Supply voltage	AC	DC
	/	
Input circuit	Single-channel	Dual-channel
<p>Base unit: Safety relay PNOZ X Driven via safety contacts</p>		/
Feedback loop	Base unit: Safety relay PNOZ X	
<p>Y1 and Y2 are inputs on the base unit; they evaluate the feedback loop</p>		

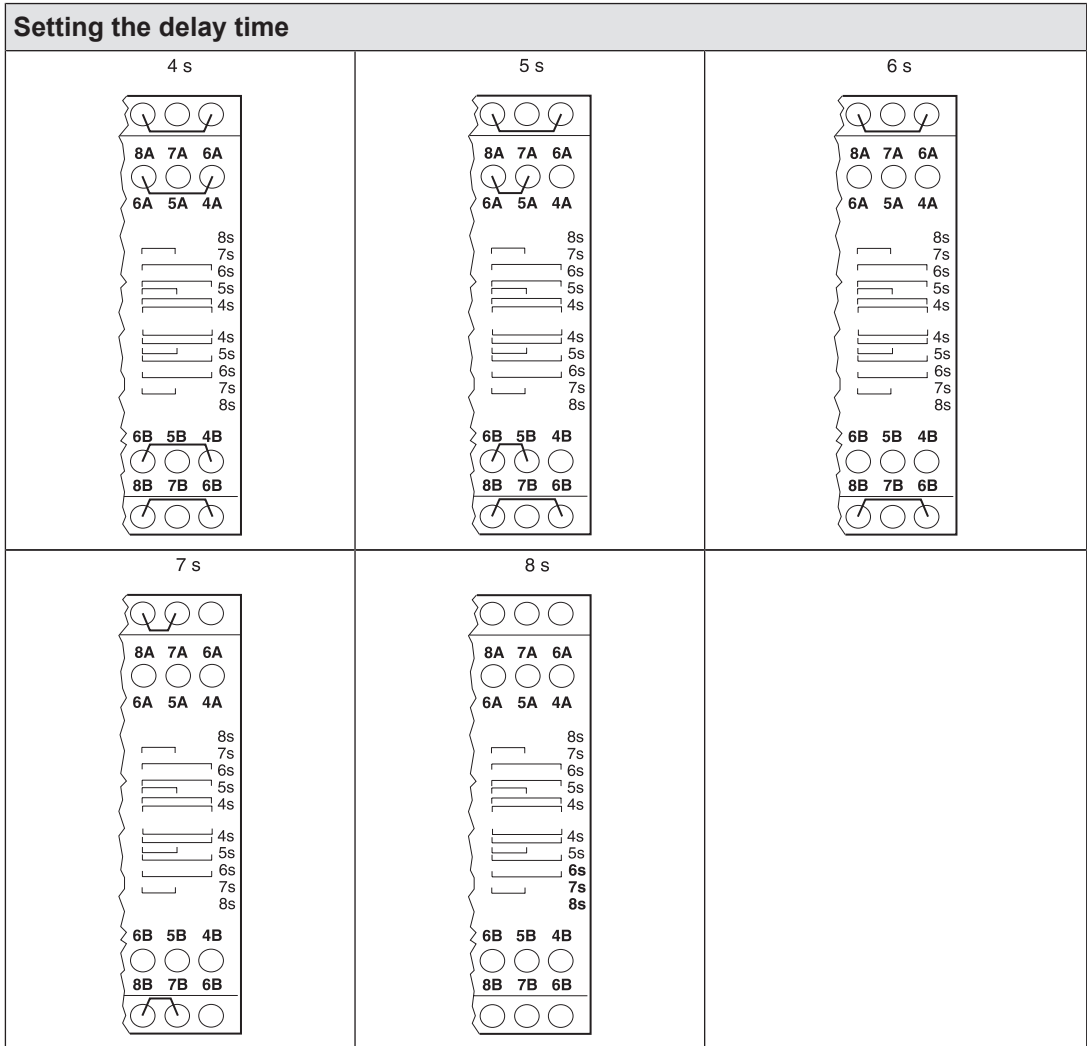

### Operation



**NOTICE**

The safety function should be checked after initial commissioning and each time the plant/machine is changed. The safety functions may only be checked by qualified personnel.

### Status indicators

LEDs indicate the status and errors during operation:



LED on



#### CH.1

Safety contacts of channel 1 are closed.



#### CH.2

Safety contacts of channel 2 are closed.

### Faults – Interference

By closing or interrupting the input circuit you can check whether the unit switches on or off correctly.

For safety reasons, the unit cannot be started if the following faults are present:

- ▶ Contact malfunction: As the contact block is connected to a base unit, reactivation will not be possible if the contacts have welded after the input circuit has opened.
- ▶ Open circuit, short circuit or earth fault ( e.g. in the input circuit)
- ▶ In the case of an error, the delay-on de-energisation safety contacts may open before the delay time has elapsed.

### Dimensions in mm

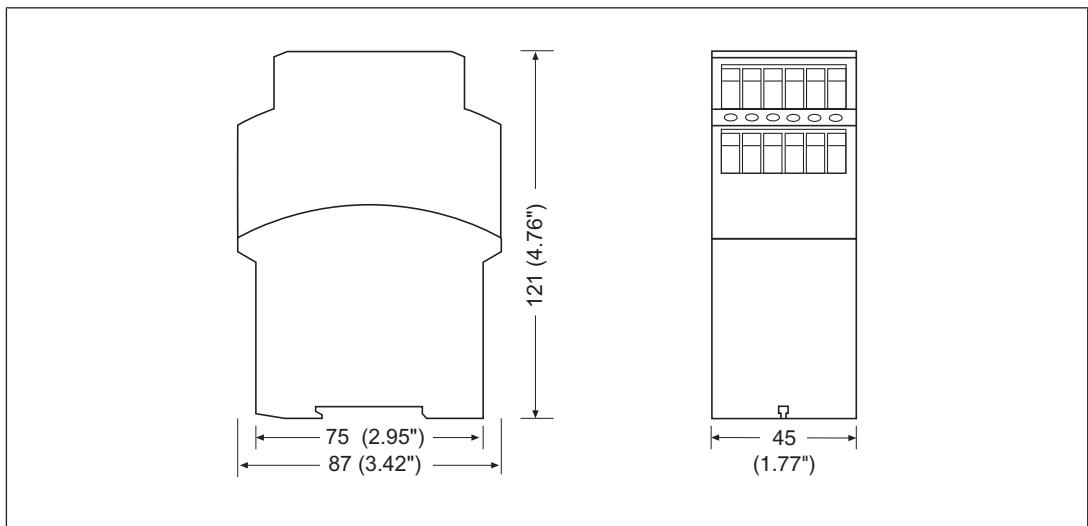

## Technical details

<b>General</b>	
Approvals	<b>CCC, CE, EAC (Eurasian), TÜV, cULus Listed</b>
<b>Electrical data</b>	
Supply voltage	
Voltage	<b>24 V</b>
Kind	<b>DC</b>
Voltage tolerance	<b>-15 %/+10 %</b>
Output of external power supply (DC)	<b>2,5 W</b>
Residual ripple DC	<b>20 %</b>
Duty cycle	<b>100 %</b>
Max. inrush current impulse	
Current pulse, A1	<b>1,7 A</b>
Pulse duration, A1	<b>280 ms</b>
<b>Inputs</b>	
Number	<b>1</b>
Voltage at	
Input circuit DC	<b>24 V</b>
Current at	
Input circuit DC	<b>70 mA</b>
Max. overall cable resistance R <sub>lmax</sub>	
Single-channel at UB DC	<b>30 Ohm</b>
<b>Relay outputs</b>	
Number of output contacts	
Safety contacts (N/O), delayed	<b>4</b>
Max. short circuit current I <sub>K</sub>	<b>1 kA</b>
Utilisation category	
In accordance with the standard	<b>EN 60947-4-1</b>
Utilisation category of safety contacts delayed	
AC1 at	<b>240 V</b>
Min. current	<b>0,01 A</b>
Max. current	<b>5 A</b>
Max. power	<b>1200 VA</b>
DC1 at	<b>24 V</b>
Min. current	<b>0,01 A</b>
Max. current	<b>5 A</b>
Max. power	<b>120 W</b>
Utilisation category	
In accordance with the standard	<b>EN 60947-5-1</b>
Utilisation category of safety contacts delayed	
AC15 at	<b>230 V</b>
Max. current	<b>5 A</b>
DC13 (6 cycles/min) at	<b>24 V</b>
Max. current	<b>4 A</b>

<b>Relay outputs</b>	
Utilisation category in accordance with UL	
Voltage	<b>240 V AC G.U. (same polarity)</b>
With current	<b>5 A</b>
Voltage	<b>24 V DC Resistive</b>
With current	<b>5 A</b>
Pilot Duty	<b>B300, R300</b>
External contact fuse protection, safety contacts	
In accordance with the standard	<b>EN 60947-5-1</b>
External contact fuse protection, delayed safety contacts	
Max. melting integral	<b>100 A<sup>2</sup>s</b>
Blow-out fuse, quick	<b>6 A</b>
Blow-out fuse, slow	<b>4 A</b>
Blow-out fuse, gG	<b>6 A</b>
Circuit breaker 24 V AC/DC, characteristic B/C	<b>4 A</b>
Conventional thermal current	<b>5 A</b>
Contact material	<b>AgSnO<sub>2</sub> + 0,2 µm Au</b>
<b>Times</b>	
Switch-on delay	
With automatic start after power on typ.	<b>320 ms</b>
With automatic start after power on max.	<b>500 ms</b>
Delay time t <sub>v</sub>	<b>4 s, 5 s, 6 s, 7 s, 8 s</b>
Time accuracy	<b>-50 %/+50 %</b>
Supply interruption before de-energisation	<b>2.000 ms</b>
<b>Environmental data</b>	
Climatic suitability	<b>EN 60068-2-78</b>
Ambient temperature	
Temperature range	<b>-10 - 55 °C</b>
Storage temperature	
Temperature range	<b>-40 - 85 °C</b>
Climatic suitability	
Humidity	<b>93 % r. h. at 40 °C</b>
Condensation during operation	<b>Not permitted</b>
EMC	<b>EN 60947-5-1, EN 61000-6-2, EN 61326-3-1</b>
Vibration	
In accordance with the standard	<b>EN 60068-2-6</b>
Frequency	<b>10 - 55 Hz</b>
Amplitude	<b>0,35 mm</b>
Airgap creepage	
In accordance with the standard	<b>EN 60947-1</b>
Overvoltage category	<b>III / II</b>
Pollution degree	<b>2</b>
Rated insulation voltage	<b>250 V</b>
Rated impulse withstand voltage	<b>4 kV</b>

<b>Environmental data</b>	
Protection type	
Mounting area (e.g. control cabinet)	<b>IP54</b>
Housing	<b>IP40</b>
Terminals	<b>IP20</b>
<b>Mechanical data</b>	
Mounting position	<b>Any</b>
Mechanical life	<b>10,000,000 cycles</b>
Material	
Bottom	<b>PPO UL 94 V0</b>
Front	<b>ABS UL 94 V0</b>
Top	<b>PPO UL 94 V0</b>
Connection type	<b>Screw terminal</b>
Mounting type	<b>Fixed</b>
Conductor cross section with screw terminals	
1 core flexible	<b>0,2 - 4 mm<sup>2</sup>, 24 - 10 AWG</b>
2 core with the same cross section, flexible with crimp connectors, no plastic sleeve	<b>0,2 - 2,5 mm<sup>2</sup>, 24 - 14 AWG</b>
2 core with the same cross section, flexible without crimp connectors or with TWIN crimp connectors	<b>0,2 - 2,5 mm<sup>2</sup>, 24 - 14 AWG</b>
Torque setting with screw terminals	<b>0,6 Nm</b>
Dimensions	
Height	<b>87 mm</b>
Width	<b>45 mm</b>
Depth	<b>121 mm</b>
Weight	<b>345 g</b>

Where standards are undated, the 2014-07 latest editions shall apply.

#### Safety characteristic data



#### NOTICE

You must comply with the safety-related characteristic data in order to achieve the required safety level for your plant/machine.

Operating mode	EN ISO 13849-1: 2008 PL	EN ISO 13849-1: 2008 Category	EN 62061 SIL CL	EN 62061 PFH <sub>D</sub> [1/h]	IEC 61511 SIL	IEC 61511 PFD	EN ISO 13849-1: 2008 T <sub>M</sub> [year]
Safety contacts, delayed <30 s	<b>PL d</b>	<b>Cat. 3</b>	<b>SIL CL 2</b>	<b>2,48E-09</b>	<b>SIL 2</b>	<b>1,47E-05</b>	<b>20</b>

All the units used within a safety function must be considered when calculating the safety characteristic data.



**INFORMATION**

A safety function's SIL/PL values are **not** identical to the SIL/PL values of the units that are used and may be different. We recommend that you use the PAScal software tool to calculate the safety function's SIL/PL values.

**Supplementary data**



**CAUTION!**

It is essential to consider the relay's service life graphs. The relay outputs' safety-related characteristic data is only valid if the values in the service life graphs are met.

The PFH value depends on the switching frequency and the load on the relay output. If the service life graphs are not accessible, the stated PFH value can be used irrespective of the switching frequency and the load, as the PFH value already considers the relay's B10d value as well as the failure rates of the other components.

**Service life graph**

The service life graphs indicate the number of cycles from which failures due to wear must be expected. The wear is mainly caused by the electrical load; the mechanical load is negligible.

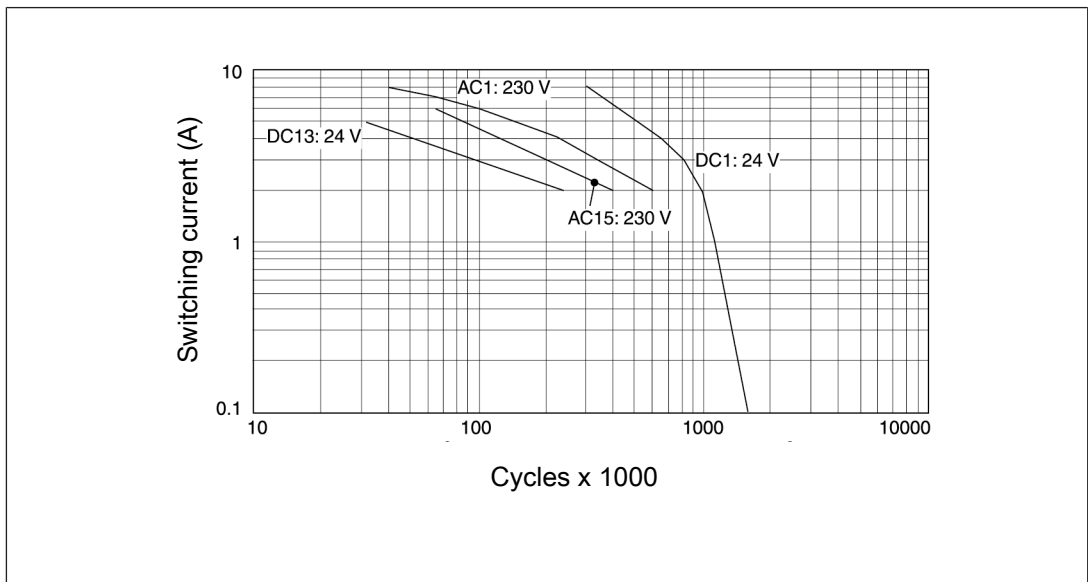

**Example**

- ▶ Inductive load: 2 A
- ▶ Utilisation category AC15
- ▶ Contact service life: 400 000 cycles

Provided the application to be implemented requires fewer than 400 000 cycles, the PFH value (see Technical details) can be used in the calculation.

To increase the service life, sufficient spark suppression must be provided on all output contacts. With capacitive loads, any power surges that occur must be noted. With DC contacts, use flywheel diodes for spark suppression.

**Order reference**

Type	Features	Connection type	Order no.
PZE X4V8	24 V DC tv: 4 - 8 s, selectable	Screw terminals	774 584

**EC declaration of conformity**

This product/these products meet the requirements of the directive 2006/42/EC for machinery of the European Parliament and of the Council. The complete EC Declaration of Conformity is available on the Internet at [www.pilz.com/downloads](http://www.pilz.com/downloads).

Representative: Norbert Fröhlich, Pilz GmbH & Co. KG, Felix-Wankel-Str. 2, 73760 Ostfildern, Germany



# ► Support

Technical support is available from Pilz round the clock.

## Americas

### Brazil

+55 11 97569-2804

### Canada

+1 888-315-PILZ (315-7459)

### Mexico

+52 55 5572 1300

### USA (toll-free)

+1 877-PILZUSA (745-9872)

## Asia

### China

+86 21 60880878-216

### Japan

+81 45 471-2281

### South Korea

+82 31 450 0680

## Australia

+61 3 95446300

## Europe

### Austria

+43 1 7986263-0

### Belgium, Luxembourg

+32 9 3217575

### France

+33 3 88104000

### Germany

+49 711 3409-444

### Ireland

+353 21 4804983

### Italy

+39 0362 1826711

## Scandinavia

+45 74436332

## Spain

+34 938497433

## Switzerland

+41 62 88979-30

## The Netherlands

+31 347 320477

## Turkey

+90 216 5775552

## United Kingdom

+44 1536 462203

## You can reach our international hotline on:

+49 711 3409-444

support@pilz.com

Pilz develops environmentally-friendly products using ecological materials and energy-saving technologies. Offices and production facilities are ecologically designed, environmentally-aware and energy-saving. So Pilz offers sustainability, plus the security of using energy-efficient products and environmentally-friendly solutions.

*Energy saving by Pilz*



Pilz GmbH & Co. KG  
Felix-Wankel-Straße 2  
73760 Ostfildern, Germany  
Tel.: +49 711 3409-0  
Fax: +49 711 3409-133  
info@pilz.com  
www.pilz.com

**PILZ**  
THE SPIRIT OF SAFETY