

J1939 Protocol Communications Module

Red Lion Automation Series



▶▶▶ J1939 Protocol Communication

The J1939 plug-in module expands the communication capabilities of our select host devices operator interface panels by seamlessly integrating with J1939 protocol networks.

Red Lion's J1939 module provides easy integration with J1939 protocol networks, and allows for translation of more than 300 different protocols. Configure the J1939 module using Red Lion's Crimson® software, which makes setup simple using an intuitive graphical user interface with drag and drop functionality.



APPLICATIONS

- > Automotive
- > Food & Beverage
- > Factory Automation
- > OEM Machine Builders
- > Water/Wastewater

PRODUCT HIGHLIGHTS

- > Seamless J1939 network integration
- > Communicate with over 300 industrial protocols

FEATURES & BENEFITS

- > J1939 protocol conversion
 - Easily integrates select Red Lion devices into J1939 protocol networks
 - Converts between J1939 and more than 300 different protocols
- > All-in-one solution
 - Removes need for external devices and communication gateways
 - Cost-effectively saves space, and time
- > -10 to 50 °C operating temperature
 - Reliably works in harsh environments
- > Powered from host device
 - Simplifies deployment by eliminating external power requirement
- > Easily programmed
 - Seamless configuration using Red Lion's Crimson desktop software

▶▶▶ J1939 Protocol Communication Module Specifications

POWER

J1939 Max Power: 1.2 W (supplied by host device)

COMMUNICATION PROPERTIES

J1939 Protocol Port:

Software programmable up to 250 Kbaud and digitally isolated

124 ohm, 1 W termination provided through switch

Port may be configured for various J1939 protocols

Isolation from host

1000 VDC for 1 minute

CERTIFICATIONS AND COMPLIANCES

CE Approved

EN 61326-1 for Industrial Locations

IEC/EN 61010-1

RoHS Compliant

ENVIRONMENTAL

Operating Temperature Range: -10 to 50 °C

Storage Temperature Range: -40 to 85 °C

Operating and Storage Humidity: 85 % max relative humidity,
non-condensing, from 0 to 50 °C

Altitude: Up to 2000 meters

COMPATIBLE HOST DEVICES

CR3000 HMIs

DA30D High Performance Data Station

ORDERING GUIDE

PART NUMBER	DESCRIPTION
CRM000CMJ1939000	Communications Module, J1939 Protocol Interface

DIMENSIONS *In inches (mm)*

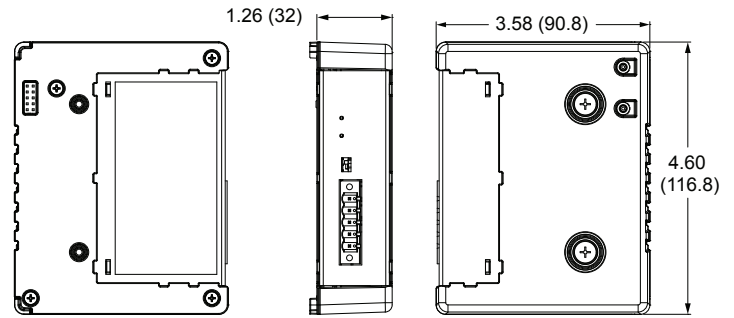

www.redlion.net

Connect. Monitor. Control.

Americas
sales@redlion.net

Asia-Pacific
asia@redlion.net

**Europe
Middle East
Africa**
europe@redlion.net

+1 (717) 767-6511

As the global experts in communication, monitoring and control for industrial automation and networking, Red Lion has been delivering innovative solutions for over forty years. Our automation, Ethernet and cellular M2M technology enables companies worldwide to gain real-time data visibility that drives productivity. Product brands include Red Lion, N-Tron and Sixnet. With headquarters in York, Pennsylvania, the company has offices across the Americas, Asia-Pacific and Europe. Red Lion is part of Spectris plc, the productivity-enhancing instrumentation and controls company. For more information, please visit www.redlion.net.

ADLD0480 110718 © 2018 Red Lion Controls, Inc. All rights reserved. Red Lion, the Red Lion logo, N-Tron and Sixnet are registered trademarks of Red Lion Controls, Inc. All other company and product names are trademarks of their respective owners.