

Model GMUIN4 - Graphite® Universal Input Module

Installation Guide

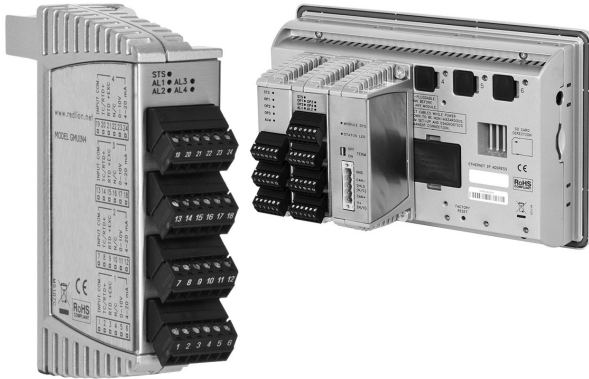

- Dedicated 4 universal input module for the Graphite products
- Accepts thermocouples, RTDs, 0/4-20 mA and 0-10 V signal inputs
- Offers complete isolation; inputs, power and core
- Ideal for data-acquisition applications



FOR USE IN HAZARDOUS LOCATIONS:
 Class I, Division 2, Groups A, B, C, and D
 T4



II 3 G Ex nA IIC T4 Gc
 -40°C ≤ T_{AMB} ≤ 75°C
 DEMKO 14 ATEX 1387X
 IECEx UL 15.0035X
 UL23UKEX2879X

GENERAL DESCRIPTION

The model GMUIN4 is a 16-bit analog input module designed for use with the Graphite products. The module provides 4 isolated universal analog inputs as a means of signal measurement for data-acquisition. The GMUIN4 accepts a wide range of thermocouples and RTDs, as well as 0/4-20 mA and 0-10 V process signals. The modules connect and communicate via proprietary USB connection to the various Graphite devices. The Graphite devices, equipped with serial ports as well as an Ethernet port(s), allows the system to share data with PCs, PLCs, and SCADA systems. The maximum number of modules varies for each Graphite device, see specific models for details.

Once programmed, the module will continue to operate independent of the Graphite device as long as power is applied. Remove power from the host device before installing or replacing any modules.

CONFIGURATION

The Graphite is configured with Windows® compatible Crimson® software. The software is an easy to use, graphical interface which provides a means of configuration and commissioning of new systems, as well as routine module re-calibration.

SAFETY SUMMARY

All safety related regulations, local codes as well as instructions that appear in this document or on equipment must be observed to ensure personal safety and to prevent damage to either the device or equipment connected to it.

Do not use these products to replace proper safety interlocking. No software-based device (or any other solid-state device) should ever be designed to be responsible for the maintenance of personnel safety or consequential equipment not equipped with safeguards. Red Lion disclaims any responsibility for damages, either direct or consequential, that result from the use of this equipment in a manner not consistent with these specifications.

 **CAUTION: Risk of Danger.**
 Read complete instructions prior to installation and operation of the unit.

 **WARNING - EXPLOSION HAZARD** - Do not disconnect equipment unless power has been switched off or area is known to be non-hazardous.

 **WARNING - EXPLOSION HAZARD** - Substitution of components may impair suitability for Class I, Division 2

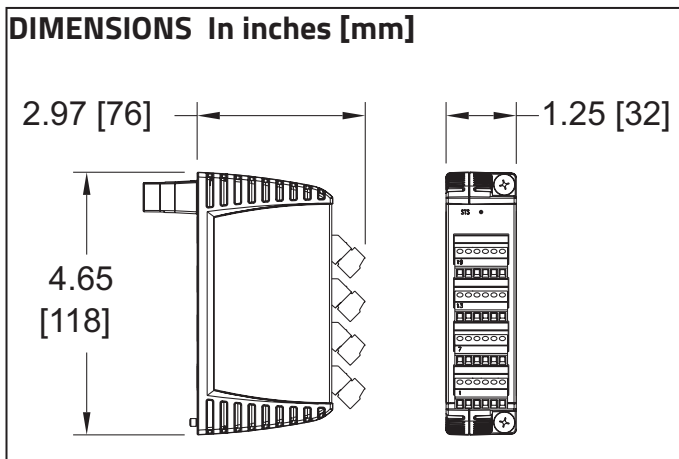

ORDERING INFORMATION

| DESCRIPTION | PART NUMBER |
|-------------------------------------|-------------|
| Graphite Module, 4 Universal Inputs | GMUIN400 |

A listing of the entire Graphite family of products and accessories can be found at www.redlion.net.

SPECIFICATIONS

1. POWER: Power will be supplied by the Graphite host device. Some modules, depending on usage may consume high levels of power. This may limit the total number of modules that can be installed on a single Graphite host. Check the Graphite module and Graphite host data sheets for specific usage and power requirements.

GMUIN4 Max Power: 1.8 W

2. LEDs:

STS - Status LED shows module condition.
AL1, AL2, AL3, AL4 - Alarm LEDs are lit during any input alarm condition.

3. MEMORY: Non-volatile memory retains all programmable parameters.

4. ISOLATION LEVEL: 500 Vrms @ 50/60 Hz for 1 minute between each Signal Input and the host Power Supply Input.

5. COMMUNICATIONS: Provided by the Graphite host device

6. INPUTS:

Effective Resolution: Full 16-bit
Sample Time: 50 msec
Common Mode Rejection: >110 dB, 50/60 Hz
Normal Mode Rejection: >50 dB, 50/60 Hz
Temperature Coefficient: 0.01%/°C
Step Response Time: 100 msec typ., 200 msec max.

7. THERMOCOUPLE INPUTS:

Types: T, E, J, K, R, S, B, N, C
Slope & Offset: Provides sensor error correction
Input Impedance: 20 M Ω
Lead Resistance Effect: 0.25 μV/Ω
Cold Junction Compensation: Less than ±1 °C typical (±1.5 °C max) over -40 to 75 °C ambient temperature
Resolution: 0.1°

| TYPE | MEASUREMENT RANGE | WIRE COLOR | |
|-------|------------------------------------|-----------------------|------------------------|
| | | ANSI | BS 1843 |
| T | -200 to +400°C -328 to +752°F | (+) Blue (-) Red | (+) White (-) Blue |
| E | -200 to +730°C -328 to +1346°F | (+) Violet (-) Red | (+) Brown (-) Blue |
| J | -200 to +760°C -328 to +1400°F | (+) White (-) Red | (+) Yellow (-) Blue |
| K | -200 to +1350°C -328 to +2462°F | (+) Yellow (-) Red | (+) Brown (-) Blue |
| R | 0 to +1768°C +32 to +3214°F | No Standard | (+) White (-) Blue |
| S | 0 to +1768°C +32 to +3214°F | No Standard | (+) White (-) Blue |
| B | +149 to +1820°C +300 to +3308°F | No Standard | No Standard |
| N | -200 to +1300°C -328 to +2372°F | (+) Orange (-) Red | (+) Orange (-) Blue |
| C | 0 to +2315°C +32 to +4199°F | No Standard | No Standard |
| W5/W6 | 0 mV to 50 mV | N/A | N/A |

Temperature Indication Accuracy: ± (0.3% of span, +1 °C).
Includes NIST conformity, cold junction effect, A/D conversion errors, temperature coefficient and linearization conformity at 23 °C after 20 minute warm up.
Probe Break Response: Upscale drive, Input Fault Alarm bit set high, ALM LED illuminates.

8. RTD INPUTS:

Type: 2 or 3 wire
Excitation: 150 μA
Lead Resistance: 15 Ω Max
Resolution: 0.1°

| TYPE | INPUT TYPE | RANGE |
|------|------------------------------------|-----------------------------------|
| 385 | 100 Ω platinum, Alpha = .00385 | -200 to +600°C -328 to +1100°F |
| 392 | 100 Ω platinum, Alpha = .003919 | -200 to +600°C -328 to +1100°F |
| 672 | 120 Ω nickel, Alpha = .00672 | -80 to +215°C -112 to +419°F |
| Ohms | Linear resistance | 0 Ω to 300 Ω |
| 428 | 50 Ω copper, Alpha = .00428 | -50 to +200 °C -58 to +392 °F |

Slope & Offset: Provides sensor error correction
Temperature Indication Accuracy: Includes NIST conformity, A/D conversion errors, temperature coefficient and linearization conformity at 23 °C after 20 minute warm up.
Probe Break Response: If channel is enabled: upscale drive, Input Fault Alarm bit set high, ALM LED illuminates.

9. CURRENT INPUTS:

Ranges: 0-20 mA or 4-20 mA
Programmable Scaling: ±30,000
Input Impedance: 10 Ω
Max. Continuous Overload: 100 mA
Accuracy: ±0.1% of span
Input Fault Response: Upscale Drive, Input Fault Alarm bit set high, ALx LED illuminates below -2 mA, and above 22 mA for 0-20 mA range; below +2 mA and above 22 mA for 4-20 mA signals.

10. VOLTAGE INPUTS:

Ranges: 0-10 VDC
Programmable Scaling: ±30,000
Input Impedance: 1 M Ω
Max. Continuous Overload: 50 VDC
Accuracy: ±0.1% of span
Input Fault Response: Upscale Drive, Input Fault Alarm bit set high, ALx LED illuminates below -0.5 VDC and above +10.5 VDC.

11. ENVIRONMENTAL CONDITIONS:

Operating Temperature Range: -40 to 75 °C T_{AMB}, or lowest range among equipment used in your Graphite system.
Consult the user manual or www.redlion.net/OpTemp for further details.
Storage Temperature Range: -40 to +85 °C T_{AMB}
Operating and Storage Humidity: 85% max relative humidity, non-condensing.
Altitude: Up to 2000 meters

12. CERTIFICATIONS AND COMPLIANCES:

CE Approved
EN 61326-1 Immunity to Industrial Locations
IEC/EN 61010-1
RoHS Compliant
ATEX/UKEX Approved
Ⓜ II 3 G Ex nA IIC T4 Gc
DEMKO 14 ATEX 1387X
EN 60079-0, -11, -15, -31
UL23UKEX2879X

IECEX Approved

Ex nA IIC T4 Gc

IECEX UL 15.0035X

IEC 60079-0, -11, -15, -31

India PESO Approved:

A/P/HQ/MH/104/7441 (P549599)

UL Listed: File #E302106

UL Hazardous: File #E317425

ABS Type Approval for Shipboard Applications

13. CONSTRUCTION: Case body is all metal construction.

14. CONNECTIONS: Removable wire clamp screw terminal blocks

Wire Gage: 28-16 AWG (0.32 mm - 1.29 mm) terminal gage wire

Torque: 1.95-2.21 inch-lbs (0.22-0.25 N-m)

15. MOUNTING: Screws to host.

16. WEIGHT: 8 oz (224 g)

Block Diagram for GMUIN4

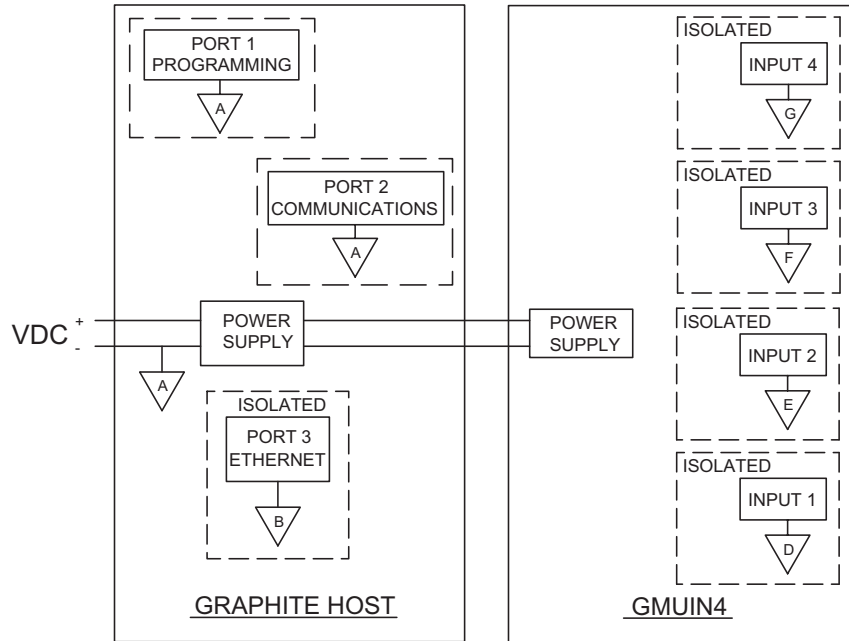

EMC INSTALLATION GUIDELINES

Visit <http://www.redlion.net/emi> for more information on EMI guidelines, Safety and CE issues as they relate to Red Lion products.

HARDWARE INSTALLATION

The physical order of all installed modules must match the modules order in Crimson. Torque screws to 6.0 pound-force inch [96 ounce-force inch] (0.68 Nm).

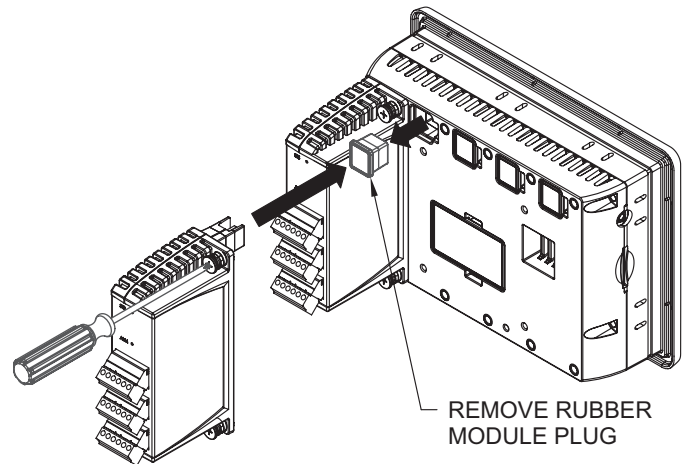

WARNING: Disconnect all power to the unit before installing or removing modules.

WIRING

Wiring Connections

All conductors should meet voltage and current ratings for each terminal. Also, cabling should conform to appropriate standards of good installation, local codes and regulations and be suitably rated for the temperatures of the environment to which it is being installed. When wiring the module, use the numbers on the label to identify the position number with the proper function. Strip the wire, leaving approximately 1/4" (6 mm) of bare wire exposed. Insert the wire into the terminal, and tighten.

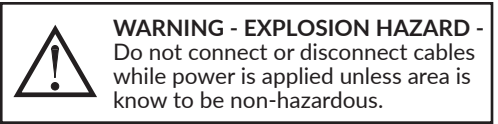

WARNING - EXPLOSION HAZARD -
Do not connect or disconnect cables while power is applied unless area is known to be non-hazardous.

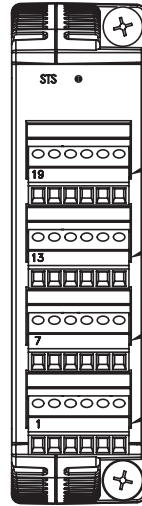

Terminals 19 to 24

Terminals 13 to 18

Terminals 7 to 12

Terminals 1 to 6

Input Connections

THERMOCOUPLE

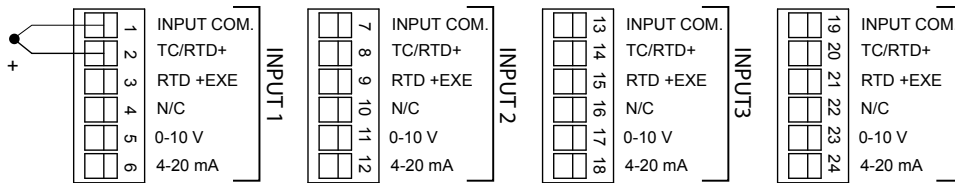

RTD

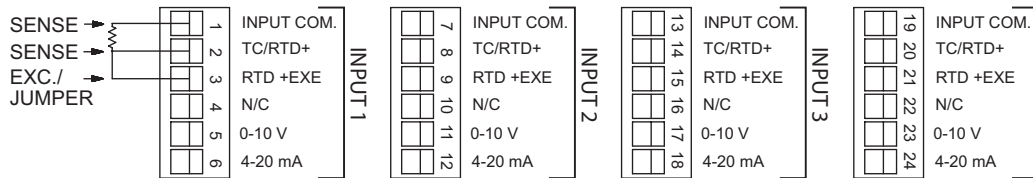

CURRENT

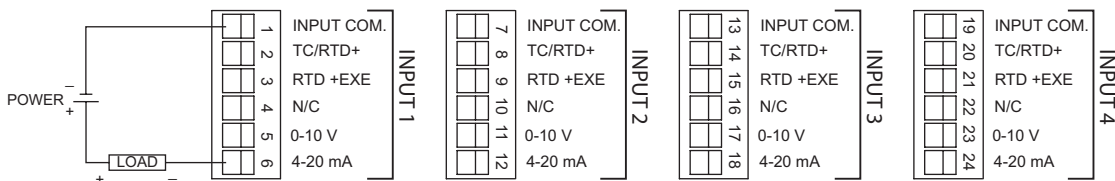

VOLTAGE

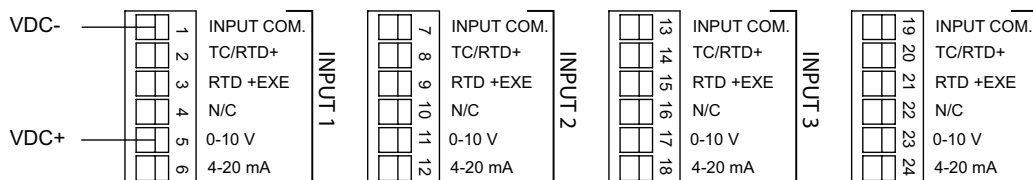

LEDs

STS – Status LED

The Status LED is a green LED that provides information regarding the state of the module. This includes indication of the various stages of the start-up routine (power-up), as well as any errors that may occur.

Startup Routine

| LED | INDICATION |
|----------------|---|
| Off | Module is currently running the boot loader and/or being flash upgraded by Crimson. |
| Flashing Green | Module switching to configuration. |
| Green | Module performing normally. |

Error States

| LED | INDICATION |
|----------------|---|
| Flashing Green | Module is controlling properly, but has lost communication with the Host. |

AL1, AL2, AL3, AL4 – Alarm LEDs

The Alarm LEDs indicates the presence of an input fault condition. When one or more Input Fault Alarm bits is high, the LED turns on.

FIRMWARE UPGRADE

The module's firmware is stored in flash memory so that software/hardware conflicts are avoided, and so features can be added in the future.

During a download, Crimson compares its own library of firmware files with those stored in the module. If they do not match, Crimson will download the necessary firmware.

CONFIGURATION

Programming is done via Crimson[®] software, a Windows[®] compatible configuration interface. Please see the Crimson manual for more information.

RED LION CONTROLS TECHNICAL SUPPORT

If for any reason you have trouble operating, connecting, or simply have questions concerning your new product, contact Red Lion's technical support.

Support: support.redlion.net

Website: www.redlion.net

Inside US: +1 (877) 432-9908

Outside US: +1 (717) 767-6511

Red Lion Controls, Inc.

35 Willow Springs Circle York, PA 17406

This page intentionally left blank.

This page intentionally left blank.

COPYRIGHT

©2023 Red Lion Controls, Inc. All Rights Reserved. Red Lion, the Red Lion logo, Graphite and Crimson are registered trademarks of Red Lion Controls. All other marks are the property of their respective owners.

LIMITED WARRANTY

(a) Red Lion Controls Inc. (the "Company") warrants that all Products shall be free from defects in material and workmanship under normal use for the period of time provided in "Statement of Warranty Periods" (available at www.redlion.net) current at the time of shipment of the Products (the "Warranty Period"). **EXCEPT FOR THE ABOVE-STATED WARRANTY, COMPANY MAKES NO WARRANTY WHATSOEVER WITH RESPECT TO THE PRODUCTS, INCLUDING ANY (A) WARRANTY OF MERCHANTABILITY; (B) WARRANTY OF FITNESS FOR A PARTICULAR PURPOSE; OR (C) WARRANTY AGAINST INFRINGEMENT OF INTELLECTUAL PROPERTY RIGHTS OF A THIRD PARTY; WHETHER EXPRESS OR IMPLIED BY LAW, COURSE OF DEALING, COURSE OF PERFORMANCE, USAGE OF TRADE OR OTHERWISE.** Customer shall be responsible for determining that a Product is suitable for Customer's use and that such use complies with any applicable local, state or federal law.

(b) The Company shall not be liable for a breach of the warranty set forth in paragraph (a) if (i) the defect is a result of Customer's failure to store, install, commission or maintain the Product according to specifications; (ii) Customer alters or repairs such Product without the prior written consent of Company.

(c) Subject to paragraph (b), with respect to any such Product during the Warranty Period, Company shall, in its sole discretion, either (i) repair or replace the Product; or (ii) credit or refund the price of Product provided that, if Company so requests, Customer shall, at Company's expense, return such Product to Company.

(d) **THE REMEDIES SET FORTH IN PARAGRAPH (c) SHALL BE THE CUSTOMER'S SOLE AND EXCLUSIVE REMEDY AND COMPANY'S ENTIRE LIABILITY FOR ANY BREACH OF THE LIMITED WARRANTY SET FORTH IN PARAGRAPH (a).**

BY INSTALLING THIS PRODUCT, YOU AGREE TO THE TERMS OF THIS WARRANTY, AS WELL AS ALL OTHER DISCLAIMERS AND WARRANTIES IN THIS DOCUMENT.