

WHITE PAPER

# TURN REMOTE SITES INTO SMART REMOTE SITES

Cellular Networking Solutions to Connect, Monitor and Control Remote Assets



**RL**  
RED LION™  
a spectris company

# TABLE OF CONTENTS

Introduction .....	3
Challenge: Monitoring Remote Assets .....	4
Scenario: Power Outage Prevention .....	5
Solution: Cellular Networking Turns Remote Sites into Smart Remote Sites .....	6
Case Study: Magnus Overcomes Geography Challenges to Meet Customer Needs .....	9
Alternative Solutions .....	10
Conclusion: Implement Reliable Cellular Networking Solution with Red Lion .....	11
The Red Lion Advantage .....	12

## EXECUTIVE SUMMARY

Every business strives to protect revenue, as well as ensure uptime and availability for customers. The oil and gas, alternative energy, power, utilities, water and waste water spaces face unique challenges when working toward these goals. They must achieve seamless connectivity, regardless of expansive territories, asset age and types of communication technology.

Using cellular networking to build smart remote sites overcomes many infrastructure, financial and safety barriers.

# INTRODUCTION

**Today's energy and utility companies operate in competitive, closely scrutinized business environments.**

These organizations must adhere to stringent regulatory requirements to prevent downtime for customers. When equipment fails, the resulting downtime leads to immediate financial and safety consequences. As competitive forces grow and business demands intensify, companies can capitalize on the benefits of the Industrial Internet of Things (IIoT) to improve their processes and data assets.

**Companies require more consistency, better visibility of networks, reduction of waste and loss, and increased compliance with regulatory requirements.** Smart technology has the ability to connect all devices and control systems. It also delivers the visibility to collect and analyze data from both new and legacy devices.

**High-availability smart sites can:**

- Minimize or eliminate unscheduled downtime
- Reduce time to repair
- Provide continuous operation, regardless of communication
- Increase visibility of equipment and sites
- Prevent unsafe conditions
- Comply with increasing regulatory conformity

## SMART TECHNOLOGY FOR A COMPETITIVE ADVANTAGE

As the connected or “smart” technology trend advances, organizations also recognize the opportunity to outfit remote sites with these new applications. Bringing connectivity, control and monitoring capabilities to remote locations enables companies to find success in the IIoT environment.

To enable remote monitoring and control of data and equipment, energy and utility companies are integrating legacy equipment with IP networks. Cellular networking offers a cost-effective and intelligent solution. It can be leveraged across remote sites as a tool to reduce downtime and repair time, as well as to increase communication reliability and improve safety conditions. The level of connectivity afforded by cellular networking presents a host of new applications that help businesses run more smoothly and efficiently. It can also reduce the resources required to manage and run operations.

# CHALLENGE: MONITORING REMOTE ASSETS

Companies are finding it more difficult than ever to maintain the integrity and operational efficiency of infrastructures. A single compromised point in an expansive energy or utility infrastructure can result in costly downtime and dissatisfied customers, and possibly lead to life-threatening situations. These challenges are heightened at remote sites where distance and visibility compound each issue.

Challenges to monitoring remote sites and remote equipment include, expansive geographic territory, aging industrial equipment, and out-of-date technology.

## CELLULAR NETWORK PERFORMANCE IMPROVEMENTS: STATISTICS FROM A REAL CUSTOMER EXAMPLE

Below are statistics from a customer who converted from a traditional SCADA network that uses a polling/ response network to a cellular network. As demonstrated in the chart below, polling a site occurred approximately 10 times faster and emergency alarms were sent 95% faster using a cellular network. The architecture difference of a cellular network is significantly more scalable and can both poll and push data.

Metric	Unit	Trunking	Cellular	Improvement
<b>Average Poll/COS Time</b> Average amount of time to poll an RTU from the FIU or time to send a "COS" – RTU change-of-state transmission, such as alarm or status change	seconds	9.6	0.9	91%
<b>Maximum Poll/COS Time</b> Max time to poll a site or send a COS transmission	seconds	63.0	1.7	97%
<b>Average Message Retry</b> Efficiency of the communication channel/ RF system – % of "failed" messages that need to be resent	percent	7.3	1.6	78%
<b>Time to send simultaneously an alarm from 5-10 RTUs.</b> Typical "storm" scenario when multiple RTUs on the same channel send alarms simultaneously (within 1 second of each other)	seconds	48-70	2.6-3.5	95%

Comparison based on:

- Statistics collected for 15 RTUs converted to cellular and operating 1-3 weeks + 2 RTUs converted to cellular and operating over 2 months.
- Statistics collected for 72 trunking RTUs operating for 62 days.

## EXPANSIVE GEOGRAPHY

Energy and utility companies commonly have large geographic footprints, ranging from multiple sites in a single city to a global network of locations. Long distances, harsh environmental conditions and limited field staff availability make these remote sites difficult to access regularly. Accessing critical information, such as equipment status and operational data, becomes even more time-consuming and costly as workforces stretch out to cover larger geographies. To maintain these expansive territories, companies must find new ways to bridge the distance.

## AGING INFRASTRUCTURE

Aging equipment creates significant challenges for businesses trying to implement new technology platforms. Older equipment was never designed to be remotely monitored in real-time and often only provides local communication ports. While legacy equipment and assets may not be ready for high-speed IP networks, they still have significant life left in them. Most companies can't afford to replace aging assets system wide, especially if the equipment is still useful. But alternative solutions, such as new communication, protocol conversion and control technologies, can keep aging infrastructures up and running smoothly.

## OUTDATED COMMUNICATION TECHNOLOGY

Companies often struggle to combine new technology with legacy systems and processes. Outdated communication systems, such as Modbus and distributed network protocols (DNP3), are typically serial-based and lack visibility into remote sites.

These communications infrastructures are slow and unable to integrate into new applications. Additionally, most legacy communication networks were not developed with built-in redundancies, and communication failures create a domino effect, which leads to stopped operations.

Communication challenges put a lot at stake: downtime, blackouts and even catastrophic gas pipeline explosions. To prevent these disastrous consequences, companies must find technology solutions to monitor and control data at every location, no matter how remote.

## SOLUTION: CELLULAR NETWORKING

To strengthen connectivity at remote sites in spite of these challenges, companies should consider adding more advanced monitoring, visibility and communication capabilities. Many oil and gas, alternative energy, power, utility, water and waste water companies are successfully integrating **cellular networking** as an intelligent, cost-effective solution.

## SCENARIO: POWER OUTAGE PREVENTION

Organizations are already witnessing the consequences of not updating and maintaining networks.

Consider a power substation located in a rural location, miles from the power company's operations center. The substation provides electricity to nearby residences and a bustling industrial complex. The power company has reduced scheduled substation visits due to cost, a reduced workforce and resource constraints. Most of the equipment in the substation is decades old and using outdated communication technology.

The technology allows the operations center to identify when a power outage occurs, but it often cannot detect the cause or resolve the issue remotely. In an emergency situation, a crew is required to travel to the substation and review all the equipment to try to find the issue. Uncovering the outage source and then repairing it could take several hours. All the while, the community is left without power.



### A Better Approach

If the electric utility had real-time, continuous connectivity to the substation, they could more quickly diagnose and address the issue. Such visibility would allow the operations center to proactively monitor equipment and notice any increased load demands on equipment. The company could take swift action by re-routing the electricity through another circuit. If the utility had the connectivity capabilities to implement demand response or distribution automation initiatives, outages in certain circumstances might be completely prevented.

# SOLUTION: CELLULAR NETWORKING

## TURN REMOTE SITES INTO SMART REMOTE SITES

By now, IIoT is beginning to take hold in every corner of industry, including energy and utilities. Remote data monitoring is critical for effective IIoT implementation, where multiple devices across a system connect with each other.

To access data in hard-to-reach locations, companies across many industrial businesses have turned to cellular networking, which adds cellular connectivity to remote terminal units (RTUs). Together, RTUs and cellular networking have the power to connect diverse legacy equipment and turn remote sites into “smart” remote sites.

Cellular networking provides secure access to data in remote locations, leveraging nationwide cellular carrier networks. Reliable, easy connectivity to data enables organizations to monitor and control critical applications throughout their system, including aging equipment at remote sites. It eliminates costly visits to remote locations to update configurations or for real-time data collection. Also, cellular RTUs bridge the communication gap between legacy systems and modern real-time communication and control applications. This solution translates to large savings.

Energy and utility companies must find a suitable partner to successfully implement smart remote sites via cellular networking. Without the right vendor, an organization may find itself with a substandard program that does not withstand industry challenges. A reliable connectivity partner can align a company’s legacy systems with next generation technology.

Finding the right partner can significantly simplify the task of selecting and deploying a cellular networking solution.

### Consider these important criteria when selecting a connectivity partner:

- Device management
- Security and regulatory standards
- Edge control
- Serial-to-IP conversion
- Cloud connectivity
- Purpose-built industrial products
- Rapid deployment
- Software development kit integration

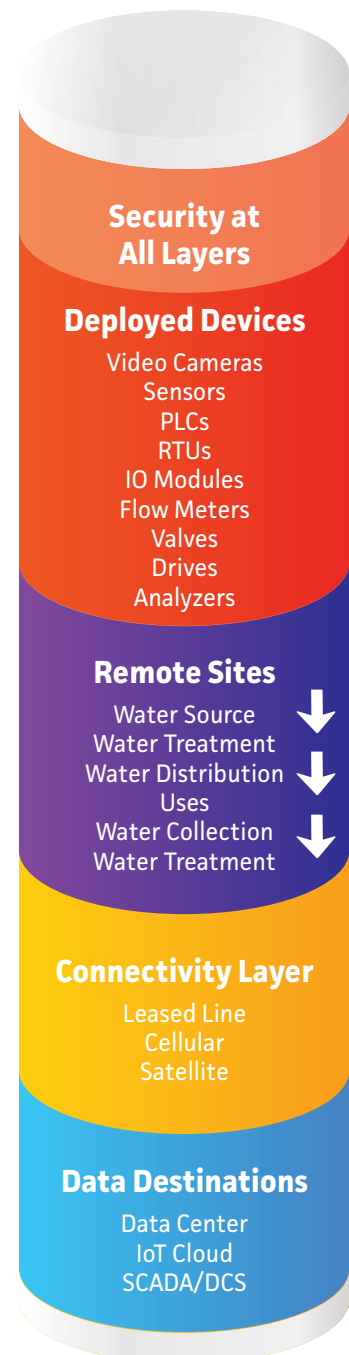

## SERIAL-TO-IP CONVERSION

Most remote sites contain legacy serial devices that communicate using Modbus, DNP3, or other protocols. To connect to modern SCADA or monitoring platforms, these protocols require a connection to an IP-based infrastructure. Serial-to-IP conversion is difficult due to speed and protocol differences. Cellular networking streamlines this process by connecting RTUs, programmable logic controllers (PLCs) and other human-machine interface (HMI) equipment. Cellular networking also configures the connected equipment to communicate at the appropriate speed and use the native protocol of the existing equipment.

Alternative solutions to serial-to-IP conversion do exist, but they require multiple gateways to communicate with the native protocol at the proper speed. They also require the extra step of converting the data to IP before finally communicating via cellular network.

## SIMPLIFIED ASSETS

Building one hardened package with integrated routing, security and cellular technologies drastically simplifies smart remote site implementation. For example, cellular RTUs with native Modbus support can poll existing RTUs and PLCs. As a single asset, cellular RTUs provide real-time access to and from sensor-level data from pumps, valves, reclosers, transformers, capacitor banks, meters and more.

Using multiple network devices—such as a cellular modem, Modbus gateway and security VPN client—is an option. But each device is costly to deploy and complicated to administer and maintain.

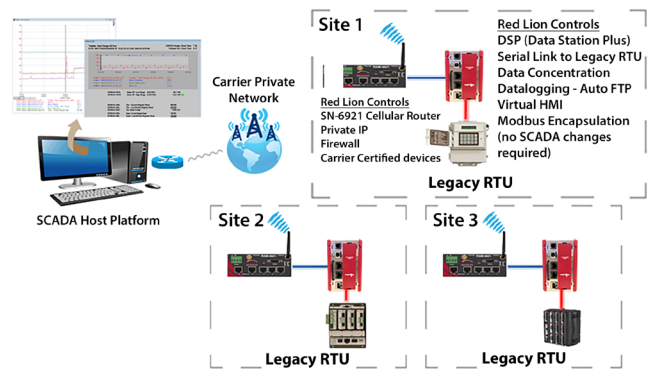
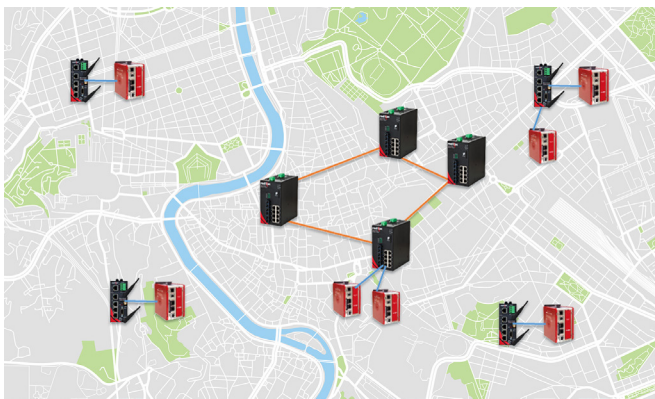

## CLOUD CONNECTIVITY

An effective cellular networking solution uses cloud technology to enable connectivity across multiple devices—regardless of age, quality or distance. Cellular networking provides reliable, secure and scalable communication to leading IIoT cloud platforms. This solution allows organizations to easily establish communication and push data to select cloud platforms in minutes.

## PURPOSE-BUILT INDUSTRIAL PRODUCTS

Industries like oil and gas, alternative energy, power, utilities, water and waste water demand technology that can withstand challenging conditions. For instance, an electric utility's on-site devices need to tolerate high electromagnetic interference (EMI). A cellular networking solution that is purpose-built for these industrial environments ensures device control and data collection continue even if communication fails.

## EDGE CONTROL

Cellular networking solutions often use edge control, which processes data as near to the data source as possible: at the edge of the network. Shifting control to the network's edge enhances operational reliability. It also reduces costs by decreasing the amount of transmitted data.

### Traditional SCADA with Control at Headquarters

Note that data is collected and transmitted from remote sites (left side) and sent all the way to the headquarters where the data is processed. If a change is required, a signal is sent all the way back. If the network becomes un-responsive, all control stops.

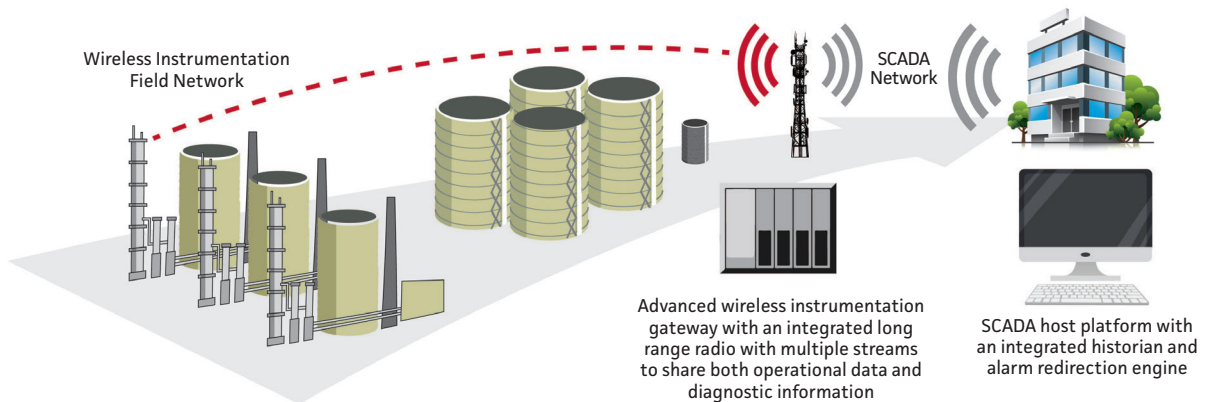

## RAPID DEPLOYMENT

When transitioning to cellular network connectivity, equipment downtime equals lost revenue. A system that rapidly deploys and connects within minutes minimizes lost time and lost revenue.

## DEVICE MANAGEMENT

When a cellular network connects thousands of devices, it is critical to incorporate a device management platform. A central dashboard gives users visibility into the health and connectivity statistics of each device.

### Modern Cellular-Based Network with Control at Edge

Equipment at remote sites connect to a cellular RTU, which has built-in edge processing capabilities. So if the network is unresponsive, the cellular RTU can still perform all control activities.

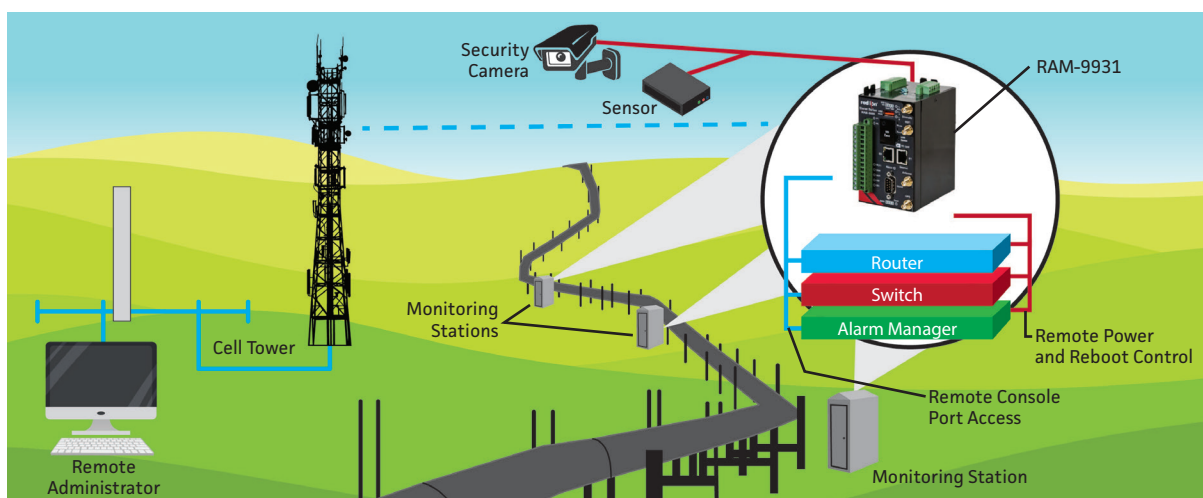



### Device Statistics May Include:

- Current connection status
- Connection history
- Firmware version
- IP address
- Alarms
- Signal level

The ideal solution configures easily and allows remote users to perform nearly any task that they would otherwise do onsite.

### SECURITY AND REGULATORY STANDARDS

Cellular connections over IP networks have more stringent security standards than direct circuit connections over modem banks and private radio networks. Energy and utility companies are also subject to strict regulatory mandates. To lower security risk, prevent breaches and avoid penalties, organizations must understand the enhanced requirements. And they must make certain any cellular network partner is up-to-date on data security best practices and industry regulations.

### SOFTWARE DEVELOPMENT KIT INTEGRATION

Another important element of an effective cellular networking solution is an integrated software development kit (SDK) that enables application customization.

Industrial environments demand flexibility to customize features to meet specific site requirements, and software tools need to integrate seamlessly with proprietary applications.

An example of this integration is the development of custom software code designed to extract specific data into specially formatted reports. Without an SDK, a company needs to dedicate additional time and resources to application support.

A smart remote site with an integrated SDK gives users the ability to monitor, reboot and control equipment without sending a technician to the field.

### CASE STUDY: MAGNUS OVERCOMES GEOGRAPHY CHALLENGES TO MEET CUSTOMER NEEDS

Magnus Services, an oil field water management and automation company based in North Dakota, has grown its business to work with oil companies across expansive geographies throughout the U.S. The company needed a way to remotely monitor and control water usage during fracking operations. Such visibility would help maintain critical water levels and prevent the overflow of tanks onsite, which can bring work to a standstill. It was also important for the company to improve the efficiency of its mobile water tank units, which are used temporarily on customer sites, then relocated.

### IMPLEMENTING CELLULAR TECHNOLOGY

Using Red Lion's IIoT-ready **RAM 6900 series cellular RTUs**, Magnus developed the H2Know solution to remotely monitor and control the supply of water to fracking operations for its customers.

The integrated solution was built to meet Magnus' specific needs, including incorporation of the automation system, platform development, monitoring and related control logic. It uses cellular networking technology to provide reliable communications from remote areas, despite extremely cold temperatures, wind and dust. With this solution, oil companies access near real-time data on water levels and water control functions at their fracking sites. H2Know also sends alerts on alarm conditions and provides recording, trending and reporting capabilities. This solution allows oil companies to take preventive steps to ensure proper water levels and gives them key insights into trend data.

### THE RESULTS

The deployment of H2Know gives Magnus customers the ability to improve overall process control, with remote monitoring and control capabilities that span all fracking operation sites. This monitoring and control is faster and reduces the need for personnel onsite, assisting in more efficient use of the water stored at each location. Operations and support staff don't need to make as many trips to remote locations, which saves time and reduces costs.

The automated system produces meaningful data through cloud-based visualization and reporting. Data is accessed via a web browser, delivering the flexibility to access important information anytime, anywhere.

# ALTERNATIVE SOLUTIONS FOR REMOTE MONITORING

## Common alternative approaches include:

### SATELLITE COMMUNICATION

Satellite communication, with a dish mounted onsite, is a common choice for incorporating connectivity at remote sites. It has the advantage of providing coverage for large areas and requires only a single-service provider. However, satellite service is charged on a per megabyte data rate, which becomes expensive. Additionally, satellite communication lacks reliability in harsh environmental conditions and heavily forested areas. Dishes need clear line-of-sight to the sky. Snow, rain and wind can make satellite communication systems inoperable.

### FIXED WIRELESS NETWORKS

Fixed wireless networks are common in environments where a company has many devices within line-of-sight of each other. The fixed wireless network aggregates the devices and uses licensed or unlicensed frequencies, 900MHz or 2.4MHz. This solution allows for data transfer without incremental fees. But any devices out of range of the fixed wireless network will be expensive or impossible to connect. If a radio on the network fails, the company will typically need to send a climber, electrician and IT expert to diagnose the issue and repair the radio, network, cable and power supply. Towers are also susceptible to lightning strikes, which can take out the entire network.

### LEASED-LINE OR DIAL-UP NETWORKS

Connectivity through leased-line or dial-up networks over copper-based lines are common in electrical utilities. Many cities already have phone lines running on traditional twisted copper, and utilities try to leverage this platform. However, leased-line or dial-up networks are slow and unreliable. In fact, most telephone companies are trying to eliminate copper-based networks due to the high cost of maintenance and the mass adoption of high-speed IP networks. The price of leased-line networks, even with their slow dial-up connections, are skyrocketing. Also, buried copper lines are easily damaged by agriculture, utility and industrial projects that dig into the ground.

### SUPERIOR SOLUTION: CELLULAR NETWORKING

 Satellite communication, fixed wireless networks and leased-line or dial-up networks can service remote sites. But the risks often outweigh the benefits. **A cellular networking solution offers advanced reliability, cost efficiency, and connectivity anywhere, anytime.**

# IMPLEMENT RELIABLE CELLULAR NETWORKING SOLUTIONS WITH RED LION

Smart remote sites connected by cellular networking deliver advanced access to existing RTUs, PLCs, HMIs and process control equipment. They use an easy-to-configure solution integrated into a single, cellular automation device.

## Even when working across multiple locations, cellular networking delivers the power to:

- Minimize or eliminate downtime
- Reduce time to repair
- Ensure continuous operation
- Increase visibility of equipment
- Improve safety conditions
- Comply with regulatory requirements

## PARTNER WITH EXPERTS IN CELLULAR NETWORKING

Energy and utility companies need a reliable partner to take on cellular networking implementation. Red Lion Controls has the experience and technology to purpose-build cellular networking programs within these unique, industrial environments. Their expertise leverages key elements of remote monitoring and control, including serial-to-IP conversion, simplified packaging, cloud connectivity, rapid deployment and more.

Red Lion is at the forefront of cellular networking solutions with its **Sixnet® series RAM® 6000 and 9000 industrial cellular RTUs**, as well as the **RAMQTT**, Red Lion's native message queuing telemetry transport (MQTT) client.

## RELIABLE, RUGGED, SECURE DESIGN

Red Lion's RAM RTUs combine a built-in Modbus gateway and state-of-the-art firewall with full router functionality and 4G LTE cellular connectivity. This design provides a compact, industrially hardened device. It is easily implemented and does not disturb the existing environment. Customers who need connectivity with a low cost of deployment benefit from the Sixnet® series, which provides access to common IIoT platforms.

## SIMPLIFY IMPLEMENTATION

Additionally, application customization is optional via an integrated SDK. RAMQTT reduces deployment and configuration complexities involved with IIoT integrations. It simplifies implementation with pre-configured profiles for AT&T® M2X, Amazon® AWSTM IoT, Cumulocity, Microsoft® Azure®, Nokia Impact and Telenor Connexion. Red Lion's MQTT client allows users to be up and running in less than two minutes per device.

Building unmatched intelligence into a single cellular networking platform provides an optimal solution to connect, monitor and control systems and processes at smart remote sites.

**Learn more about cellular networking solutions with Red Lion Controls. Visit [www.redlion.net/RAM](http://www.redlion.net/RAM).**

# THE RED LION ADVANTAGE

As the global experts in communication, monitoring and control for industrial automation and networking, Red Lion has been delivering innovative visual management solutions for over 45 years.

Our automation, Ethernet and cellular M2M technology enables companies worldwide to gain real-time data visibility that drives productivity and profitability. Product brands include Red Lion, N-Tron® and Sixnet®. Red Lion Controls is headquartered in York, Pennsylvania and has offices across the Americas, Asia-Pacific and Europe. Red Lion Controls is part of Spectris plc, the productivity-enhancing instrumentation and controls company.

**CONNECT. MONITOR. CONTROL.**

**Americas** | [sales@redlion.net](mailto:sales@redlion.net)

**Asia-Pacific** | [asia@redlion.net](mailto:asia@redlion.net)

**Europe, Middle East, Africa** | [europe@redlion.net](mailto:europe@redlion.net)

+1(717) 767-6511

[www.redlion.net](http://www.redlion.net)



a spectris company

**[www.redlion.net](http://www.redlion.net)**

ADLD0440 062419 © 2019 Red Lion Controls, Inc. All rights reserved. Red Lion, the Red Lion logo, N-Tron and Sixnet are registered trademarks of Red Lion Controls, Inc. All other company and product names are trademarks of their respective owners.