

HSPA+ Cellular Communication Module



- COMPATIBLE WITH
CR3000 HMI's
DA300D High Performance Data Station
- CONFIGURED USING CRIMSON SOFTWARE (VERSION 3.1 OR LATER)
- SUPPORTS HSPA+ CELLULAR DATA CONNECTIVITY WITH FALL BACK TO 3G AND 2G
- UP TO 21 MBPS DOWNLINK/5.76 MBPS UPLINK SPEEDS
- POWERED AND CONFIGURED FROM HOST DEVICE



FOR USE IN HAZARDOUS LOCATIONS:
Class I, Division 2, Groups A, B, C, and D
T4



GENERAL DESCRIPTION

The HSPA+ cellular communication module provides the host device cellular data connectivity. The cellular standard adopted in this module is HSPA+ with fallback capability to 3G and 2G. It can get speeds up to 21 Mbps downlink and 5.76 Mbps uplink. It's built upon the GSM standard, offered in the US through AT&T and T-Mobile and widely available throughout the world. HSPA+ can be used for services such as Wireless Application Protocol (WAP) access, Short Message Service (SMS), and for Internet connectivity.

The HSPA module is penta-band, allowing it to work in frequencies across the Americas, Europe and Asia. US and Canada work in the 850/1900 MHz bands, while Europe, Middle East, Africa and most of Asia work in the 900/1700/2100 MHz HSPA+ frequencies.

The HSPA module requires the addition of a SIM (Subscriber Identity Module) card, which is inserted into the holder prior to installation of the HSPA module. The SIM card securely stores the service-subscriber key (IMSI) used to identify a subscriber, and is used to connect to the network to obtain an IP address from the cellular provider.

The modules connect and communicate via proprietary USB connection to the various host devices. The host devices, equipped with serial ports as well as Ethernet port(s), allow the system to share data with PCs, PLCs and SCADA systems.

CONFIGURATION

The module is configured with Windows® compatible Crimson® 3.1 software. The software is an easy to use, graphical interface which provides a means of configuration and commissioning of new systems, as well as routine module re-calibration.

SAFETY SUMMARY

All safety related regulations, local codes and instructions that appear in this literature or on equipment must be observed to ensure personal safety and to prevent damage to either the instrument or equipment connected to it. If equipment is used in a manner not specified by the manufacturer, the protection provided by the equipment may be impaired.

Do not use this unit to directly command motors, valves, or other actuators not equipped with safeguards. To do so can be potentially harmful to persons or equipment in the event of a fault to the unit.

The antenna used for this module must be installed to provide a separation distance of at least 7.87 inches (20 cm) from all persons.



CAUTION: Risk of Danger.

Read complete instructions prior to installation and operation of the unit.



WARNING - EXPLOSION HAZARD - DO NOT DISCONNECT EQUIPMENT UNLESS POWER HAS BEEN SWITCHED OFF OR AREA IS KNOWN TO BE NON-HAZARDOUS.

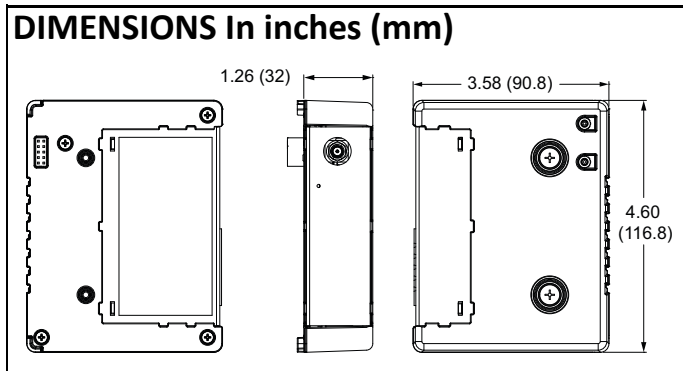

SPECIFICATIONS

1. **POWER:** Power will be supplied by the host device.
HSPA Max Power:
HSPA+ Mode: During continuous active webserver traffic
Instantaneous maximum: **5.4 W**
Average: 3.5 W
GPRS Mode:
Instantaneous maximum: **15.0 W** (1.1 msec every 4.6 msec)
Average: 8.5 W
2. **LINK STATUS LEDs:**
Link Status - Link Status LED shows cellular link condition.
3. **COMMUNICATIONS:**
Isolation from HSPA Antenna connector to host device: 500 VDC for 1 minute.
4. **ENVIRONMENTAL CONDITIONS:**
Operating Temperature Range: -10 to 50 °C
Storage Temperature Range: -40 to +85 °C
Operating and Storage Humidity: 85% max. relative humidity, non-condensing.
Altitude: Up to 2000 meters
5. **CERTIFICATIONS AND COMPLIANCES:**
CE Approved
EN 61326-1 Immunity to Industrial Locations
IEC/EN 61010-1
RoHS Compliant
UL Hazardous: File #E317425
Note: The HSPA module has been tested and found to comply with the limits for a Class A digital device, pursuant to part 15 of the FCC rules.
6. **ANTENNA CONNECTOR:**
SMA Female connector requires:
50 Ohm antenna with SMA male connector
Penta-band HSPA+ antenna (850/900/1700/1900/2100 MHz) for global support.
Dual-band (850/1900 MHz) antenna for US and Canada only
Dual band (900/2100 MHz) for Europe only

- Voltage Standing Wave Ratio (VSWR) should not exceed 2.0:1
The antenna cable should be 50Ω impedance, RG178/U or RG174/U type and be able to connect to the RSMA (Male) jack bulkhead. The antenna could be horizontal, vertical or right angled. Longer antenna cable would equate to signal loss.
7. **CONSTRUCTION:** Case body is polycarbonate with stainless steel cover.
 8. **CONNECTIONS:** Antenna connector for external antenna.
 9. **MOUNTING:** Screws to host
 10. **WEIGHT:** 7.0 oz (198.45 g)

Block Diagram for HSPA

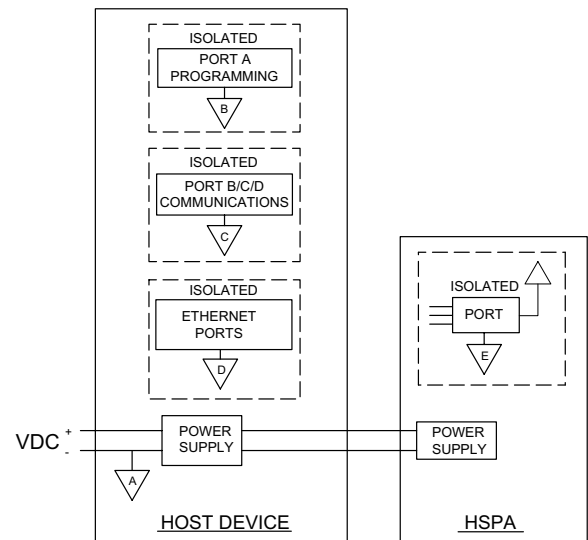

EMC INSTALLATION GUIDELINES

Although Red Lion Controls products are designed with a high degree of immunity to Electromagnetic Interference (EMI), proper installation and wiring methods must be followed to ensure compatibility in each application. The type of the electrical noise, source or coupling method into a unit may be different for various installations. Cable length, routing, and shield termination are very important and can mean the difference between a successful or troublesome installation. Listed are some EMI guidelines for a successful installation in an industrial environment.

1. A unit should be mounted in a metal enclosure, which is properly connected to protective earth.
2. Use shielded cables for all Signal and Control inputs. The shield connection should be made as short as possible. The connection point for the shield depends somewhat upon the application. Listed below are the recommended methods of connecting the shield, in order of their effectiveness.
 - a. Connect the shield to earth ground (protective earth) at one end where the unit is mounted.
 - b. Connect the shield to earth ground at both ends of the cable, usually when the noise source frequency is over 1 MHz.
3. Never run Signal or Control cables in the same conduit or raceway with AC power lines, conductors, feeding motors, solenoids, SCR controls, and heaters, etc. The cables should be run through metal conduit that is properly grounded. This is especially useful in applications where cable runs are long and portable two-way radios are used in close proximity or if the installation is near a commercial radio transmitter. Also, Signal or Control cables within an enclosure should be routed as far away as possible from contactors, control relays, transformers, and other noisy components.
4. Long cable runs are more susceptible to EMI pickup than short cable runs.
5. In extremely high EMI environments, the use of external EMI suppression devices such as Ferrite Suppression Cores for signal and

control cables is effective. The following EMI suppression devices (or equivalent) are recommended:

Fair-Rite part number 0443167251 (Red Lion Controls #FCOR0000)
Line Filters for input power cables:

Schaffner # FN2010-1/07 (Red Lion Controls #LFIL0000)

6. To protect relay contacts that control inductive loads and to minimize radiated and conducted noise (EMI), some type of contact protection network is normally installed across the load, the contacts or both. The most effective location is across the load.

- a. Using a snubber, which is a resistor-capacitor (RC) network or metal oxide varistor (MOV) across an AC inductive load is very effective at reducing EMI and increasing relay contact life.

- b. If a DC inductive load (such as a DC relay coil) is controlled by a transistor switch, care must be taken not to exceed the breakdown voltage of the transistor when the load is switched. One of the most effective ways is to place a diode across the inductive load. Most Red Lion products with solid state outputs have internal zener diode protection. However external diode protection at the load is always a good design practice to limit EMI. Although the use of a snubber or varistor could be used.

Red Lion part numbers: Snubber: SNUB0000

Varistor: ILS11500 or ILS23000

7. Care should be taken when connecting input and output devices to the instrument. When a separate input and output common is provided, they should not be mixed. Therefore a sensor common should NOT be connected to an output common. This would cause EMI on the sensitive input common, which could affect the instrument's operation.

Visit www.redlion.net/emi for more information on EMI guidelines, Safety and CE issues as they relate to Red Lion products.

HARDWARE INSTALLATION

SIM CARD INSTALLATION

Before installing the module in the host device, a SIM Card from one of the GSM/HSPA+ providers, with data enabled, has to be purchased and inserted into the module SIM Card slot. To insert the SIM card, the wrapper has to be removed from the module.

1. Remove the metal cover from the HSPA unit by releasing the four plastic retaining tabs and sliding it off of unit.
2. Insert the SIM card as shown in Figure 1.
3. Replace the metal cover onto the unit until it snaps in place.

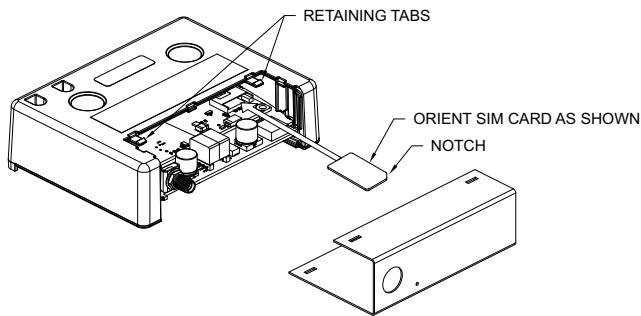

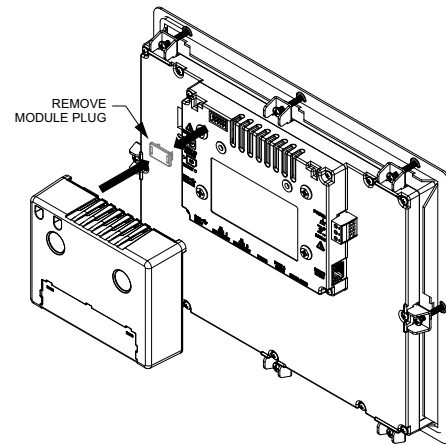

Figure 1

 **WARNING - EXPLOSION HAZARD - DO NOT CONNECT OR DISCONNECT CABLES WHILE POWER IS APPLIED UNLESS AREA IS KNOWN TO BE NON-HAZARDOUS.**

HSPA MODULE INSTALLATION

Remove polycarbonate module plug and attach module to host device. Torque screws to 6.0 pound-force inch [96 ounce-force inch] (0.68 Nm).



Installing Module on CR3000

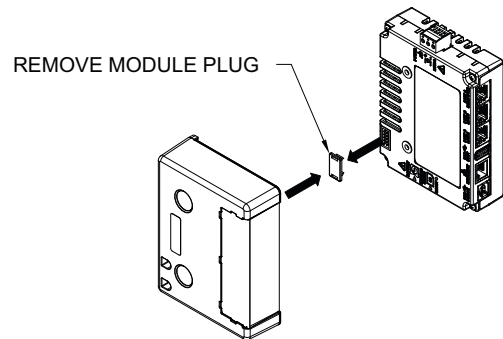

Installing Module on DA30D

 **WARNING: Disconnect all power to the unit before installing or removing modules.**

ANTENNA INSTALLATION

Antennas intended for use in Class 1, Division 2 and Zone 2 Hazardous Locations must be installed within the end use enclosure. For remote mounting in an unclassified location, routing and installation of the antennas shall be in accordance with the National Electrical Codes requirements.

COMMUNICATING WITH THE HSPA MODULE

LED

LINK STATUS – Modem Status LED

The Link Status LED is a green LED that provides information regarding the state of the modem module's cellular connection. The status is described below.

OFF	No power to the unit
ON	Powered and not registered on the cellular network.
BLINKING	Powered and registered on the cellular network.

CONFIGURING A HSPA MODULE

The HSPA module is configured using Crimson 3.1 software. After choosing the appropriate Cellular modem module, it is set up as a PPP Modem client, PPP Modem Server or SMS via HSPA+ Modem. Find additional information in your host device hardware literature and the Crimson 3.1 manual.

SIM CARD DETAILS

A SIM Card with data plan enabled has to be installed on the module before installing the module in the host device. Please contact your GSM/HSPA+ cellular network provider on setting up an account and data plan. The carrier should provide you with a SIM card to insert into the module, along with the APN, username, and password for data connectivity.

TROUBLESHOOTING

If for any reason you have trouble operating, connecting, or simply have questions concerning your new unit, contact Red Lion's technical support.

Email: support@redlion.net

Website: www.redlion.net

Inside US: +1 (877) 432-9908

Outside US: +1 (717) 767-6511

ORDERING INFORMATION

TYPE	DESCRIPTION	PART NUMBER
Input Module	Host Module, HSPA+ Cellular Module	CRM000 CM CMOD0 000
Antennas	2G/3G 3" hinged antenna	ANT-TG090113
	2G/3G/4G LTE low profile direct permanent mount antenna, IP67 rated	ANT-G30B108111
	2G/3G 4.5" whip magnetic mount antenna, IP65 rated	ANT-GA107201111
	2G/3G low profile direct permanent mount antenna, IP65 rated	ANT-G21B301111

A listing of the entire CR3000 and DA30D family of products and accessories can be found at www.redlion.net.

3G/HSPA+ activation availability is carrier dependent. Please check with your cellular carrier to determine if 3G/HSPA+ is available in your area.

LIMITED WARRANTY

(a) Red Lion Controls Inc. (the "Company") warrants that all Products shall be free from defects in material and workmanship under normal use for the period of time provided in "Statement of Warranty Periods" (available at www.redlion.net) current at the time of shipment of the Products (the "Warranty Period"). **EXCEPT FOR THE ABOVE-STATED WARRANTY, COMPANY MAKES NO WARRANTY WHATSOEVER WITH RESPECT TO THE PRODUCTS, INCLUDING ANY (A) WARRANTY OF MERCHANTABILITY; (B) WARRANTY OF FITNESS FOR A PARTICULAR PURPOSE; OR (C) WARRANTY AGAINST INFRINGEMENT OF INTELLECTUAL PROPERTY RIGHTS OF A THIRD PARTY; WHETHER EXPRESS OR IMPLIED BY LAW, COURSE OF DEALING, COURSE OF PERFORMANCE, USAGE OF TRADE OR OTHERWISE.** Customer shall be responsible for determining that a Product is suitable for Customer's use and that such use complies with any applicable local, state or federal law.

(b) The Company shall not be liable for a breach of the warranty set forth in paragraph (a) if (i) the defect is a result of Customer's failure to store, install, commission or maintain the Product according to specifications; (ii) Customer alters or repairs such Product without the prior written consent of Company.

(c) Subject to paragraph (b), with respect to any such Product during the Warranty Period, Company shall, in its sole discretion, either (i) repair or replace the Product; or (ii) credit or refund the price of Product provided that, if Company so requests, Customer shall, at Company's expense, return such Product to Company.

(d) **THE REMEDIES SET FORTH IN PARAGRAPH (c) SHALL BE THE CUSTOMER'S SOLE AND EXCLUSIVE REMEDY AND COMPANY'S ENTIRE LIABILITY FOR ANY BREACH OF THE LIMITED WARRANTY SET FORTH IN PARAGRAPH (a).**