

Model GMPB - Graphite® PROFIBUS-DP Module

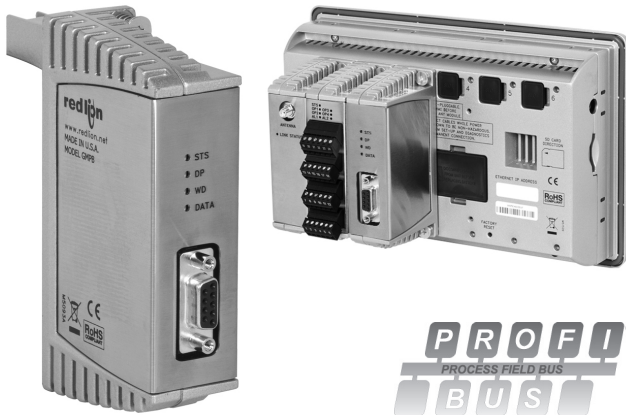

- CONNECTS GRAPHITE PRODUCTS TO PROFIBUS-DP NETWORK
- CONFIGURED USING CRIMSON® SOFTWARE (VERSION 3.0 OR LATER)
- STANDARD 9-PIN D-SUB CONNECTOR INTERFACE
- OPERATES FROM 9.6 KBAUD TO 12 MBAUD WITH AUTOMATIC BAUD RATE DETECTION
- DIAGNOSTIC LEDs INDICATE MODULE STATUS



FOR USE IN HAZARDOUS LOCATIONS:
 Class I, Division 2, Groups A, B, C, and D
 T4



II 3 G Ex nA IIC T4 Gc
 -40°C ≤ T_{AMB} ≤ 75°C
 DEMKO 14 ATEX 1387X
 IECEx UL 15.0035X



GENERAL DESCRIPTION

The Model GMPB adds PROFIBUS DP connectivity to any Graphite product. This allows a high speed exchange of blocks of data, at data rates up to 12 MBaud, between the Graphite host device and a Master PLC on a PROFIBUS network. The DP suffix refers to “Decentralized Periphery”, which is used to describe distributed I/O devices connected via a fast serial data link with a central controller.

The PROFIBUS-DP Network connects through a 9-pin D-subminiature female connector. Power for the module is provided by the Graphite host device. The PROFIBUS-DP Network is fully isolated from the Graphite host.

The modules connect and communicate via proprietary USB connection to the various Graphite devices. The Graphite devices, equipped with serial ports as well as Ethernet port(s), allows the system to share data with PCs, PLCs and SCADA systems.

CONFIGURATION

The Graphite is configured with Windows® compatible Crimson 3 software. The software is an easy to use, graphical interface which provides a means of configuration and commissioning of new systems, as well as routine module re-calibration.

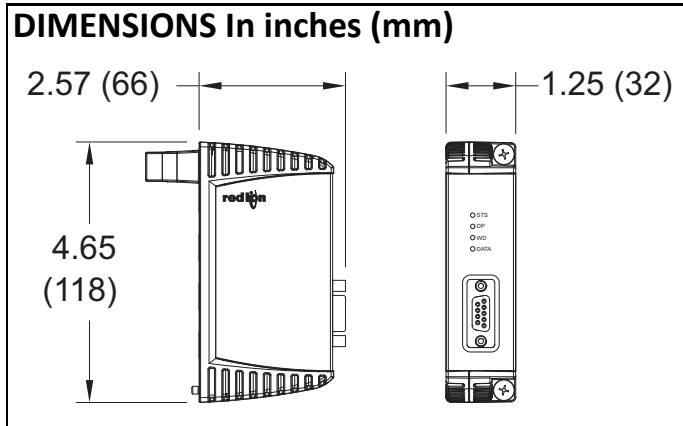

SAFETY SUMMARY

All safety related regulations, local codes and instructions that appear in this literature or on equipment must be observed to ensure personal safety and to prevent damage to either the instrument or equipment connected to it. If equipment is used in a manner not specified by the manufacturer, the protection provided by the equipment may be impaired.

Do not use this unit to directly command motors, valves, or other actuators not equipped with safeguards. To do so can be potentially harmful to persons or equipment in the event of a fault to the unit.



CAUTION: Risk of Danger.

Read complete instructions prior to installation and operation of the unit.



WARNING - EXPLOSION HAZARD - DO NOT DISCONNECT EQUIPMENT UNLESS POWER HAS BEEN SWITCHED OFF OR AREA IS KNOWN TO BE NON-HAZARDOUS.



WARNING - EXPLOSION HAZARD - SUBSTITUTION OF COMPONENTS MAY IMPAIR SUITABILITY FOR CLASS I, DIVISION 2.

ORDERING INFORMATION

DESCRIPTION	PART NUMBER
Graphite Module, PROFIBUS Interface	GMPBDP00

A listing of the entire Graphite family of products and accessories can be found at www.redlion.net.

SPECIFICATIONS

1. **POWER:** Power will be supplied by the Graphite host device. Some modules, depending on usage may consume high levels of power. This may limit the total number of modules that can be installed on a single Graphite host. Check the Graphite module and Graphite host data sheets for specific usage and power requirements.

GMPB Max Power: 2.6 W

2. **LEDs:**

STS - Status LED shows module condition.

DP - LED shows communications state.

WD - LED shows communications state.

DATA - LED shows data exchange.

3. **COMMUNICATIONS:**

PROFIBUS Port: FIELDBUS TYPE: PROFIBUS-DP per EN 50 170.

Baud Rates: 9.6 Kbaud to 12 Mbaud, auto baud rate detection.

Station Address: software programmable in the range 1 to 125.

Output Power: +5 VDC @ 90 mA max. on the D-Sub connector pins 5 (GND) and 6 (+5 V).

Network Isolation: 500 Vrms @ 50/60 Hz for 1 minute between PROFIBUS-DP network and Graphite host.

4. **ENVIRONMENTAL CONDITIONS:**

Operating Temperature Range: -40 to 75 °C, or lowest range among equipment used in your Graphite system. Consult the user manual or www.redlion.net/OpTemp for further details.

Storage Temperature Range: -40 to +85 °C

Operating and Storage Humidity: 85% max. relative humidity, non-condensing.

Altitude: Up to 2000 meters

5. **CERTIFICATIONS AND COMPLIANCES:**

CE Approved

EN 61326-1 Immunity to Industrial Locations

IEC/EN 61010-1

RoHS Compliant

ATEX Approved

Ⓜ II 3 G Ex nA IIC T4 Gc

DEMKO 14 ATEX 1387X

EN 60079-0, -15

IECEx Approved

Ex nA IIC T4 Gc

IECEx UL 15.0035X

IEC 60079-0, -15

UL Listed: File #E302106

UL Hazardous: File #E317425

ABS Type Approval for Shipboard Applications

6. **CONSTRUCTION:** Case body is all metal construction.

7. **CONNECTIONS:** Pluggable DB9F connector.

8. **MOUNTING:** Screws to host

9. **WEIGHT:** 8 oz (224 g)

Block Diagram for GMPB

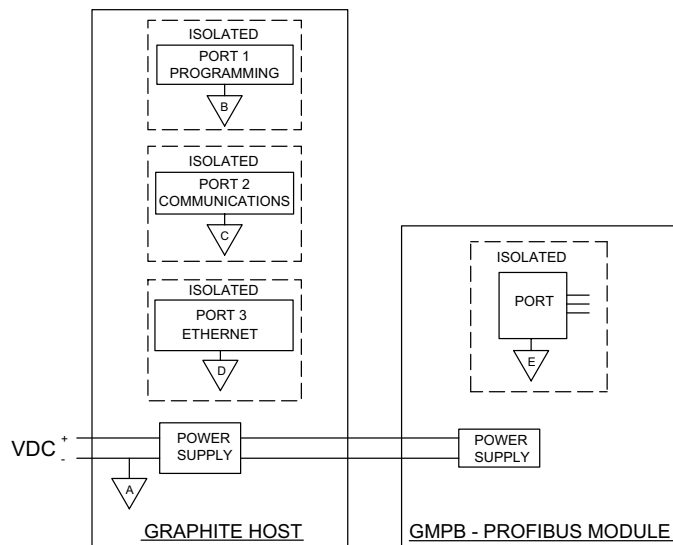

EMC INSTALLATION GUIDELINES

Although Red Lion Controls products are designed with a high degree of immunity to Electromagnetic Interference (EMI), proper installation and wiring methods must be followed to ensure compatibility in each application. The type of the electrical noise, source or coupling method into a unit may be different for various installations. Cable length, routing, and shield termination are very important and can mean the difference between a successful or troublesome installation. Listed are some EMI guidelines for a successful installation in an industrial environment.

1. A unit should be mounted in a metal enclosure, which is properly connected to protective earth.
2. Use shielded cables for all Signal and Control inputs. The shield connection should be made as short as possible. The connection point for the shield depends somewhat upon the application. Listed below are the recommended methods of connecting the shield, in order of their effectiveness.
 - a. Connect the shield to earth ground (protective earth) at one end where the unit is mounted.
 - b. Connect the shield to earth ground at both ends of the cable, usually when the noise source frequency is over 1 MHz.
3. Never run Signal or Control cables in the same conduit or raceway with AC power lines, conductors, feeding motors, solenoids, SCR controls, and heaters, etc. The cables should be run through metal conduit that is properly grounded. This is especially useful in applications where cable runs are long and portable two-way radios are used in close proximity or if the installation is near a commercial radio transmitter. Also, Signal or Control cables within an enclosure should be routed as far away as possible from contactors, control relays, transformers, and other noisy components.
4. Long cable runs are more susceptible to EMI pickup than short cable runs.
5. In extremely high EMI environments, the use of external EMI

suppression devices such as Ferrite Suppression Cores for signal and control cables is effective. The following EMI suppression devices (or equivalent) are recommended:

Fair-Rite part number 0443167251 (Red Lion Controls #FCOR0000)

Line Filters for input power cables:

Schaffner # FN2010-1/07 (Red Lion Controls #LFIL0000)

6. To protect relay contacts that control inductive loads and to minimize radiated and conducted noise (EMI), some type of contact protection network is normally installed across the load, the contacts or both. The most effective location is across the load.
 - a. Using a snubber, which is a resistor-capacitor (RC) network or metal oxide varistor (MOV) across an AC inductive load is very effective at reducing EMI and increasing relay contact life.
 - b. If a DC inductive load (such as a DC relay coil) is controlled by a transistor switch, care must be taken not to exceed the breakdown voltage of the transistor when the load is switched. One of the most effective ways is to place a diode across the inductive load. Most Red Lion products with solid state outputs have internal zener diode protection. However external diode protection at the load is always a good design practice to limit EMI. Although the use of a snubber or varistor could be used.
Red Lion part numbers: Snubber: SNUB0000
Varistor: ILS11500 or ILS23000

7. Care should be taken when connecting input and output devices to the instrument. When a separate input and output common is provided, they should not be mixed. Therefore a sensor common should NOT be connected to an output common. This would cause EMI on the sensitive input common, which could affect the instrument's operation.

Visit www.redlion.net/emi for more information on EMI guidelines, Safety and CE issues as they relate to Red Lion products.

HARDWARE INSTALLATION

The physical order of all installed modules must match the modules order in Crimson. Torque screws to 6.0 pound-force inch [96 ounce-force inch] (0.68 Nm).

 **WARNING: Disconnect all power to the unit before installing or removing modules.**

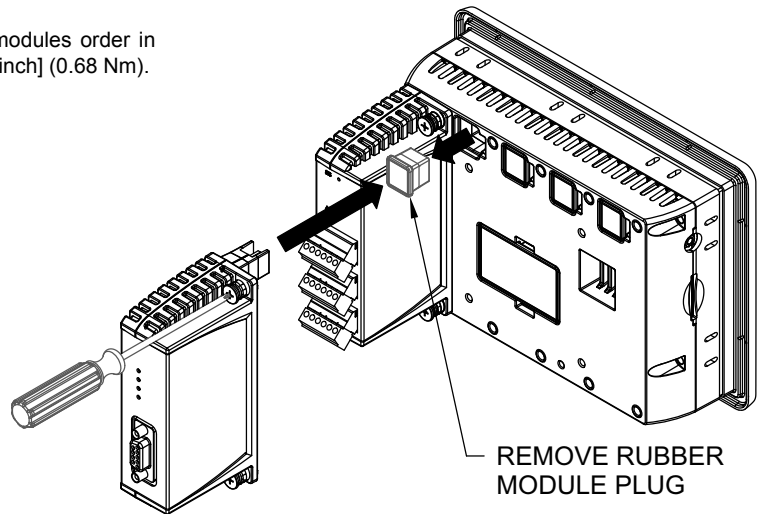



COMMUNICATING WITH THE GMPB MODULE

CONFIGURATION

Programming is done via Crimson 3 software, a Windows® compatible configuration interface. Please see the Crimson manual for more information.

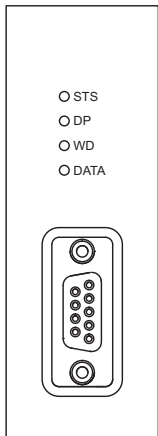
LEDs



 **WARNING - EXPLOSION HAZARD - DO NOT CONNECT OR DISCONNECT CABLES WHILE POWER IS APPLIED UNLESS AREA IS KNOWN TO BE NON-HAZARDOUS.**

STS – STATUS LED

The Status LED is a green LED that provides information regarding the state of the module. This includes indication of the various stages of the start-up routine (power-up), as well as any errors that may occur.

Startup Routine

Off	Module is currently running the boot loader and/or being flash upgraded by Crimson.
Flashing Green	Module switching to configuration.
Green	Module performing normally.

Error States

Flashing Green	Module is running, but has lost communication with the Host.
----------------	--

COMMUNICATIONS LEDs

The module has 3 LEDs that provide communications state information.

DP (RED)	WD (GREEN)	DATA (RED)	DESCRIPTION
SLOW ALTERNATING FLASH	SLOW ALTERNATING FLASH	OFF	Baud Search
ON	OFF	OFF	Baud Control
FAST FLASH	SLOW FLASH	OFF	Waiting for Parameter Telegram
SLOW FLASH	FAST FLASH	OFF	Waiting for Configuration Telegram
OFF	OFF	ON	Data Exchange

FIRMWARE UPGRADE

The module's firmware is stored in flash memory so that software/hardware conflicts are avoided, and so features can be added in the future.

During a download, Crimson compares its own library of firmware files with those stored in the module. If they do not match, Crimson will download the necessary firmware.

GRAPHITE TROUBLESHOOTING

If for any reason you have trouble operating, connecting, or simply have questions concerning your new Graphite unit, contact Red Lion's technical support.

Email: support@redlion.net
 Website: www.redlion.net
 Inside US: +1 (877) 432-9908
 Outside US: +1 (717) 767-6511

GSD FILE

The GSD file and associated bitmap are part of the Crimson installation, and can also be downloaded from the Red Lion website.

DATA TAGS

PROFIBUS data blocks have no concept or knowledge of data type or structure – they are described by a size in bytes. Crimson's Tag based approach to data allows for data of mixed types, bytes, 16-bit words and 32-bit words, to be mapped into a single data block.

A PROFIBUS master exchanges data with slaves as separate input and output blocks. Data transfer direction is described with respect to the

PROFIBUS Network such that input data is transferred to the network, or written by the Graphite, and output data is transferred from the network, or read by the Graphite.

Data Tags are mapped to either an Input Block and are Write only, or an Output Block and are Read Only. The Access must be selected to reflect this.

The Data Offset is the byte address of the Data Tag within the Data Block.

The Data Type is the actual size in bytes of the data that will be mapped into the Data Block.

LIMITED WARRANTY

(a) Red Lion Controls Inc. (the "Company") warrants that all Products shall be free from defects in material and workmanship under normal use for the period of time provided in "Statement of Warranty Periods" (available at www.redlion.net) current at the time of shipment of the Products (the "Warranty Period"). **EXCEPT FOR THE ABOVE- STATED WARRANTY, COMPANY MAKES NO WARRANTY WHATSOEVER WITH RESPECT TO THE PRODUCTS, INCLUDING ANY (A) WARRANTY OF MERCHANTABILITY; (B) WARRANTY OF FITNESS FOR A PARTICULAR PURPOSE; OR (C) WARRANTY AGAINST INFRINGEMENT OF INTELLECTUAL PROPERTY RIGHTS OF A THIRD PARTY; WHETHER EXPRESS OR IMPLIED BY LAW, COURSE OF DEALING, COURSE OF PERFORMANCE, USAGE OF TRADE OR OTHERWISE.** Customer shall be responsible for determining that a Product is suitable for Customer's use and that such use complies with any applicable local, state or federal law.

(b) The Company shall not be liable for a breach of the warranty set forth in paragraph (a) if (i) the defect is a result of Customer's failure to store, install, commission or maintain the Product according to specifications; (ii) Customer alters or repairs such Product without the prior written consent of Company.

(c) Subject to paragraph (b), with respect to any such Product during the Warranty Period, Company shall, in its sole discretion, either (i) repair or replace the Product; or (ii) credit or refund the price of Product provided that, if Company so requests, Customer shall, at Company's expense, return such Product to Company.

(d) **THE REMEDIES SET FORTH IN PARAGRAPH (c) SHALL BE THE CUSTOMER'S SOLE AND EXCLUSIVE REMEDY AND COMPANY'S ENTIRE LIABILITY FOR ANY BREACH OF THE LIMITED WARRANTY SET FORTH IN PARAGRAPH (a).**