

# TANDEM clamping block

## KSH plus, KSH-LH plus, KSH-F plus

### Assembly and Operating Manual



## Imprint

### Copyright:

This manual is protected by copyright. The author is SCHUNK GmbH & Co. KG. All rights reserved. Any reproduction, processing, distribution (making available to third parties), translation or other usage - even excerpts - of the manual is especially prohibited and requires our written approval.

### Technical changes:

We reserve the right to make alterations for the purpose of technical improvement.

**Document number:** 0489065

**Version:** 05.00 |18/05/2020|en

© H.-D. SCHUNK GmbH & Co.

All rights reserved.

Dear Customer,

thank you for trusting our products and our family-owned company, the leading technology supplier of robots and production machines.

Our team is always available to answer any questions on this product and other solutions. Ask us questions and challenge us. We will find a solution!

Best regards,

Your SCHUNK team

H.-D. SCHUNK GmbH & Co.

Spanntechnik KG

Lothringer Str. 23

D-88512 Mengen

Tel. +49-7572-7614-0

Fax +49-7572-7614-1099

info@de.schunk.com

schunk.com

## Table of contents

<b>1</b>	<b>General</b> .....	<b>5</b>
1.1	About this manual .....	5
1.1.1	Presentation of Warning Labels.....	5
1.1.2	Applicable documents.....	6
1.1.3	Sizes.....	6
1.2	Warranty.....	6
1.3	Scope of Delivery.....	6
<b>2</b>	<b>Basic safety notes</b> .....	<b>7</b>
2.1	Intended use.....	7
2.2	Not intended use.....	7
2.3	Constructional changes .....	7
2.4	Spare parts.....	8
2.5	Use of special chuck jaws .....	8
2.6	Environmental and operating conditions.....	8
2.7	Personnel qualification.....	9
2.8	Personal protective equipment.....	9
2.9	Notes on safe operation.....	10
2.10	Transport .....	10
2.11	Malfunctions.....	11
2.12	Disposal.....	11
2.13	Fundamental dangers.....	11
2.13.1	Protection during handling and assembly .....	12
2.13.2	Protection during commissioning and operation .....	12
2.13.3	Protection against dangerous movements.....	13
2.13.4	Notes on particular risks .....	13
<b>3</b>	<b>Technical Data</b> .....	<b>16</b>
<b>4</b>	<b>Tightening torques for screws</b> .....	<b>18</b>
<b>5</b>	<b>Assembly</b> .....	<b>19</b>
5.1	Assembly of the Clamping Block on the machine table.....	19
5.2	Connecting the clamping block .....	20
5.3	Hydraulic circuit diagram .....	23
<b>6</b>	<b>Control of proper function</b> .....	<b>24</b>
<b>7</b>	<b>Troubleshooting</b> .....	<b>25</b>
<b>8</b>	<b>Maintenance and care</b> .....	<b>26</b>
8.1	Disassembly and assembly the clamping block .....	26

8.2	Assembling the piston seal.....	30
8.3	Testing the leakage and tightness of the hydraulic system.....	31
<b>9</b>	<b>Sealing kits, accessory packs and parts lists .....</b>	<b>33</b>
9.1	Sealing kit lists .....	33
9.2	Accessory packs.....	34
9.3	Part lists .....	36
<b>10</b>	<b>Assembly drawings.....</b>	<b>45</b>
10.1	KSH plus, KSH-LH plus.....	45
10.2	KSH-F plus .....	46
<b>11</b>	<b>Translation of the original declaration of incorporation.....</b>	<b>47</b>

# 1 General

## 1.1 About this manual

This manual contains important information for a safe and appropriate use of the product.

This manual is an integral part of the product and must be kept accessible for the personnel at all times.





Before starting work, the personnel must have read and understood this operating manual. Prerequisite for safe working is the observance of all safety instructions in this manual.

Illustrations in this manual are provided for basic understanding and may differ from the actual product design.

In addition to these instructions, the documents listed under [\(☞ 1.1.2, Page 6\)](#) are applicable.

### 1.1.1 Presentation of Warning Labels

To make risks clear, the following signal words and symbols are used for safety notes.

	<p><b>⚠ DANGER</b></p> <p><b>Danger for persons!</b> Non-observance will inevitably cause irreversible injury or death.</p>
	<p><b>⚠ WARNING</b></p> <p><b>Dangers for persons!</b> Non-observance can lead to irreversible injury and even death.</p>
	<p><b>⚠ CAUTION</b></p> <p><b>Dangers for persons!</b> Non-observance can cause minor injuries.</p>
	<p><b>CAUTION</b></p> <p><b>Material damage!</b> Information about avoiding material damage.</p>

### 1.1.2 Applicable documents

- General terms of business \*
- Catalog data sheet of the purchased product \*

The documents marked with an asterisk (\*) can be downloaded on our homepage **schunk.com**

### 1.1.3 Sizes

This operating manual applies to the following sizes:

- KSH plus 64, 100, 140, 160
- KSH-LH plus 64, 100, 140, 160, 250
- KSP-H plus 64, 100, 140, 160

## 1.2 Warranty

The warranty period is 24 months after delivery date from factory or 500 000 cycles\*, if it is used as intended, under the following conditions:

- Observe the applicable documents, ([☞ 1.1.2, Page 6](#))
- Observe the ambient conditions and operating conditions, ([☞ 2.6, Page 8](#))
- Observance of the specified care and maintenance instructions ([☞ 8, Page 26](#))

Parts touching the workpiece and wear parts are not included in the warranty.

\* A cycle consists of a complete clamping process ("Open" and "Close").

## 1.3 Scope of Delivery

### Clamping block

#### KSH plus or KSH-LH plus or KSH-F plus

(without top jaws)

ACCESSORY KIT:

(for contents, see sealing kit and parts list)([☞ 9.1, Page 33](#))

## 2 Basic safety notes

### 2.1 Intended use

- This product is intended for clamping and holding workpieces on machine tools and other suitable technical devices.
- It is designed to be set up on a machine table or machine pallets.
- The product may only be used within the scope of its technical data, ([↩ 3, Page 16](#)).
- The product is intended for industrial and industry-oriented use.
- Appropriate use of the product includes compliance with all instructions in this manual.

### 2.2 Not intended use

- The product is not being used as intended if, for example:
- It is used as lifting equipment, as a press, as a punching tool, as a lathe chuck, as a drill or as a cutting tool.
- It is used in working environments that are not permissible.
- Workpieces are not properly clamped.
- Safety regulations are disregarded and persons are working at this product (for example, to machine clamped workpieces) without additional protective equipment.
- The technical data specified by the manufacturer are exceeded during usage.
- It is used with machines/systems or workpieces that are not designed to be used with it.

### 2.3 Constructional changes

#### Implementation of structural changes

By conversions, changes, and reworking, e.g. additional threads, holes, or safety devices can impair the functioning or safety of the product or damage it.

- Structural changes should only be made with the written approval of SCHUNK.

## 2.4 Spare parts

### Use of unauthorized spare parts

Using unauthorized spare parts can endanger personnel and damage the product or cause it to malfunction.

- Use only original spare parts or spares authorized by SCHUNK.

## 2.5 Use of special chuck jaws

### Requirements of the chuck jaws

When using special chuck jaws, please observe the following rules:

- The chuck jaws should be designed to be as low as possible. The clamping point must be as close as possible to the housing. (clamping points at a greater distance cause higher surface pressures in the jaw guidance and can significantly reduce the clamping force.)
- Do not use welded jaws.
- Reduce operating pressure for higher clamping points.

## 2.6 Environmental and operating conditions

### Required ambient conditions and operating conditions

Incorrect ambient and operating conditions can make the product unsafe, leading to the risk of serious injuries, considerable material damage and/or a significant reduction to the product's life span.

- Make sure that the product is used only in the context of its defined application parameters, ([👉 3, Page 16](#)).
- Make sure that the product is a sufficient size for the application.
- Ensure that maintenance and lubrication intervals are observed, ([👉 8, Page 26](#)).
- Ensure that the environment is free from ferromagnetic particles or chips.



## 2.7 Personnel qualification

### Inadequate qualifications of the personnel

If the personnel working with the product is not sufficiently qualified, the result may be serious injuries and significant property damage.

- All work may only be performed by qualified personnel.
- Before working with the product, the personnel must have read and understood the complete assembly and operating manual.
- Observe the national safety regulations and rules and general safety instructions.

The following personal qualifications are necessary for the various activities related to the product:

- Trained electrician** Due to their technical training, knowledge and experience, trained electricians are able to work on electrical systems, recognize and avoid possible dangers and know the relevant standards and regulations.
- Qualified personnel** Due to its technical training, knowledge and experience, qualified personnel is able to perform the delegated tasks, recognize and avoid possible dangers and knows the relevant standards and regulations.
- Instructed person** Instructed persons were instructed by the operator about the delegated tasks and possible dangers due to improper behaviour.
- Service personnel of the manufacturer** Due to its technical training, knowledge and experience, service personnel of the manufacturer is able to perform the delegated tasks and to recognize and avoid possible dangers.

## 2.8 Personal protective equipment

### Use of personal protective equipment

Personal protective equipment serves to protect staff against danger which may interfere with their health or safety at work.

- When working on and with the product, observe the occupational health and safety regulations and wear the required personal protective equipment.
- Observe the valid safety and accident prevention regulations.
- Wear protective gloves to guard against sharp edges and corners or rough surfaces.

- Wear heat-resistant protective gloves when handling hot surfaces.
- Wear protective gloves and safety goggles when handling hazardous substances.
- Wear close-fitting protective clothing and also wear long hair in a hairnet when dealing with moving components.

## 2.9 Notes on safe operation

### **Incorrect handling of the personnel**

Incorrect handling and assembly may impair the product's safety and cause serious injuries and considerable material damage.

- Avoid any manner of working that may interfere with the function and operational safety of the product.
- Use the product as intended.
- Observe the safety notes and assembly instructions.
- Do not expose the product to any corrosive media. This does not apply to products that are designed for special environments.
- Eliminate any malfunction immediately.
- Observe the care and maintenance instructions.
- Observe the current safety, accident prevention and environmental protection regulations regarding the product's application field.

### **IMPORTANT!**

Following a longer shutdown period (more than approx. 6 hours), always re-tension the clamping device in order to compensate for the setting properties of the clamping situation or possible pressure losses and the resulting loss of clamping force.

## 2.10 Transport

### **Handling during transport**

Incorrect handling during transport may impair the product's safety and cause serious injuries and considerable material damage.

- When handling heavy weights, use lifting equipment to lift the product and transport it by appropriate means.
- Secure the product against falling during transportation and handling.

- Stand clear of suspended loads.

## 2.11 Malfunctions

### Behavior in case of malfunctions

- Immediately remove the product from operation and report the malfunction to the responsible departments/persons.
- Order appropriately trained personnel to rectify the malfunction.
- Do not recommission the product until the malfunction has been rectified.
- Test the product after a malfunction to establish whether it still functions properly and no increased risks have arisen.

## 2.12 Disposal

### Handling of disposal

The incorrect handling of disposal may impair the product's safety and cause serious injuries as well as considerable material and environmental harm.

- Follow local regulations on dispatching product components for recycling or proper disposal.

## 2.13 Fundamental dangers

### General

- Observe safety distances.
- Never deactivate safety devices.
- Before commissioning the product, take appropriate protective measures to secure the danger zone.
- Disconnect power sources before installation, modification, maintenance, or calibration. Ensure that no residual energy remains in the system.
- If the energy supply is connected, do not move any parts by hand.
- Do not reach into the open mechanism or movement area of the product during operation.

### **2.13.1 Protection during handling and assembly**

#### **Incorrect handling and assembly**

Incorrect handling and assembly may impair the product's safety and cause serious injuries and considerable material damage.

- Have all work carried out by appropriately qualified personnel.
- For all work, secure the product against accidental operation.
- Observe the relevant accident prevention rules.
- Use suitable assembly and transport equipment and take precautions to prevent jamming and crushing.

#### **Incorrect lifting of loads**

Falling loads may cause serious injuries and even death.

- Stand clear of suspended loads and do not step into their swiveling range.
- Never move loads without supervision.
- Do not leave suspended loads unattended.

### **2.13.2 Protection during commissioning and operation**

#### **Falling or violently ejected components**

Falling and violently ejected components can cause serious injuries and even death.

- Take appropriate protective measures to secure the danger zone.
- Never step into the danger zone during operation.



### 2.13.3 Protection against dangerous movements



#### Unexpected movements



Residual energy in the system may cause serious injuries while working with the product.



- Switch off the energy supply, ensure that no residual energy remains and secure against inadvertent reactivation.
- Never rely solely on the response of the monitoring function to avert danger. Until the installed monitors become effective, it must be assumed that the drive movement is faulty, with its action being dependent on the control unit and the current operating condition of the drive. Perform maintenance work, modifications, and attachments outside the danger zone defined by the movement range.
- To avoid accidents and/or material damage, human access to the movement range of the machine must be restricted. Limit/prevent accidental access for people in this area due through technical safety measures. The protective cover and protective fence must be rigid enough to withstand the maximum possible movement energy. EMERGENCY STOP switches must be easily and quickly accessible. Before starting up the machine or automated system, check that the EMERGENCY STOP system is working. Prevent operation of the machine if this protective equipment does not function correctly.



### 2.13.4 Notes on particular risks

	 <b>WARNING</b>
	<p><b>Risk of injury to operating personnel if the clamping block fails because the technical data have been exceeded and a workpiece is released or parts fly off!</b></p> <ul style="list-style-type: none"> <li>• The technical data specified by the manufacturer for using the clamping block must never be exceeded.</li> <li>• The clamping block may only be used on machines and facilities that fulfill the minimum requirements of the EC Machinery Directive 2006/42/EC; specifically, they must have effective technical measures to protect against possible mechanical hazards.</li> </ul>

	 <b>WARNING</b>
	<p><b>Risk of injury from workpiece loss if compressed air or oil pressure fails or is reduced and from improper controlling (operator error)!</b></p> <ul style="list-style-type: none"> <li>• Use pressure maintenance valves.</li> <li>• Safeguards in user program.</li> </ul>

	 <b>WARNING</b>
	<p><b>Risk of injury from clamping block or chuck jaws falling during transport, installation or removal!</b></p> <ul style="list-style-type: none"> <li>• Make sure the clamping block and chuck jaws do not fall during transport, installation or removal.</li> <li>• Use a crane and/or a transport truck for transportation.</li> <li>• Only install the clamping block on machines with the appropriate connection dimensions.</li> </ul>

	 <b>CAUTION</b>
	<p><b>Risk of crushing from chuck jaws opening and closing when manually loading and unloading!</b></p> <ul style="list-style-type: none"> <li>• Do not reach between the chuck jaws.</li> <li>• Wear personal protective equipment.</li> <li>• Prevent the clamping block from being actuated unintentionally.</li> <li>• Use automated loading.</li> </ul>

	 <b>CAUTION</b>
	<p><b>Risk of slipping or falling if the operational environment of the clamping block is not clean (e.g. contaminated with cooling lubricants or oil).</b></p> <ul style="list-style-type: none"> <li>• Ensure that the working environment is clean before starting assembly and installation work.</li> <li>• Wear suitable safety boots.</li> <li>• Follow the safety and accident-prevention regulations when operating the clamping block, especially when working with machine tools and other technical equipment.</li> </ul>

**⚠ CAUTION**

**Risk of burns due to workpieces with high temperatures.**

- Wear protective gloves when removing the workpieces.
- Automatic loading is preferred.

### 3 Technical Data

Installation position	any
Operating temperature	+5°C to +60°C
Noise emission [dB(A)]	≤ 70
Actuation	Hydraulic oil
Requirement for the pressure medium	filtered (10 µm), viscosity 46 mm/s at 40°C in line with ISO VG
Volumetric flow	max. 2 l/min
Towing oil loss	max. 0.5 mg/cycle

Designation	KSH plus				KSH-LH plus					KSH-F plus			
	64	100	140	160	64	100	140	160	250	64	100	140	160
Stroke per jaw [mm]	2	2	3	3	4	6	7	8	15	2	4	6	6
Clamping force* at max. pressure [kN]	4.5	18	30	45	4.5	16	26	40	50	4	18	30	45
max. pressure [bar]	60	60	60	60	120	120	120	120	45	60	60	60	60
Repeat accuracy** [mm]	0.01	0.01	0.015	0.02	0.01	0.01	0.015	0.02	0.03	0.01	0.01	0.015	0.02
max. jaw height [mm]	60	60	60	60	60	60	60	60	150	60	60	60	60
Weight [kg]	1.5	5	9.5	14	1.5	5	9.5	14	35	1.5	5	9.5	14

\* Clamping force is the arithmetic sum of the individual forces occurring at the chuck jaws at distance "H" (see catalog).

\*\* Distribution of the end position spread after 100 consecutive strokes.

Dimension	KSH plus, KSH-LH plus, KSH-F plus				
	64	100	140	160	250
A	36	90	126	146	180
B	56	64	92	106	160
∅ C	4H7 x 7.5	6H7 x 12	8H7 x 14	8H7 x 14	10H7 x 20
D	50	80	110	125	200 x 180
E	17	29.5	25 (2x)	50	45
F	17	32	45.5	40	80
G	21	34.5	51.8	59.7	50
H	33.6	55	74	82	140



Dimension	KSH plus, KSH-LH plus, KSH-F plus				
	64	100	140	160	250
I	41	64	91	104	170
J	55.7	74.2	77.7	87.2	103.2
K	33.3	47	46	50	57
L	14	15	13.5	15	20
M	30	57	88	100	45 (off-center)
N	M6	M8	M8	M10	M12
O	12	15	15.5	18	20
P	2.5	4	3.5	4	5
Ø Q	8f7	10f7	10f7	12f7	14f7
Ø R	8	11	11	13	16
S	4	4.5	5.5	6	6

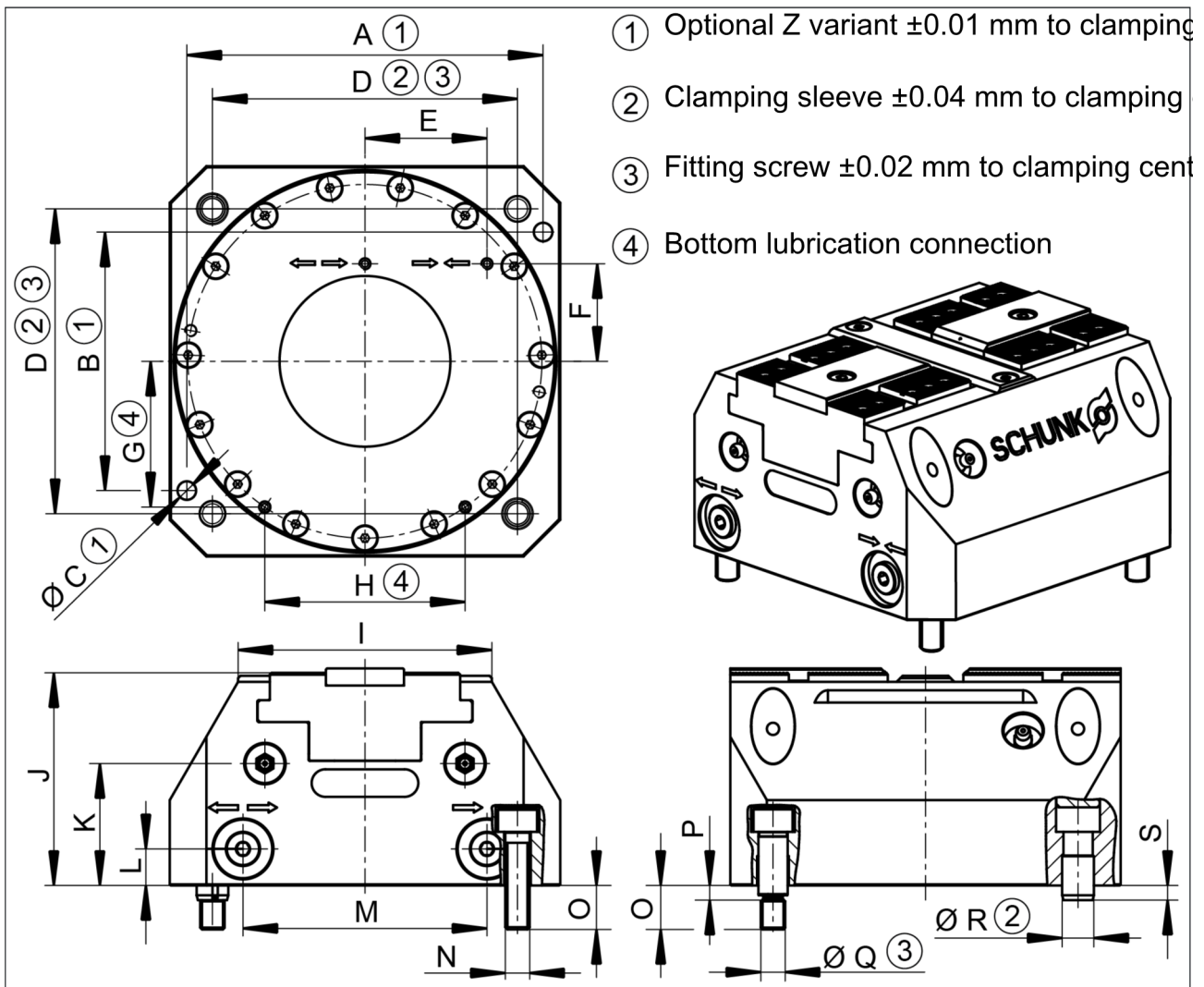

## 4 Tightening torques for screws

**Tightening torques to mount the clamping system on the machine table (screw quality 10.9)**

Screw size	M4	M5	M6	M8	M10	M12	M14	M16	M18	M20	M22	M24
Admissible torque $M_A$ (Nm)	4.2	7.5	13	28	50	88	120	160	200	290	400	500

**Tightening torques to mount top jaws on the TANDEM clamping block (screw quality 12.9)**

Screw size	M4	M5	M6	M8	M10	M12	M14	M16	M20	M24
Tightening torques $M_A$ (Nm)	5	9	15	32	62	108	170	262	510	880

**Tightening torques to mount the chuck piston onto the cylinder piston (screw quality 12.9)**

Variante	Screw size	M5	M8	M10	M12
KSH ....., KSH-F .....	Tightening torques $M_A$ (Nm)	9	32	62	108
KSH-LH .....	Tightening torques $M_A$ (Nm)	9	32	75	140

## 5 Assembly

The numbers shown for individual components refer to the assembly illustrations or clamping block connections and to the "Drawings" chapter. ([👉 10, Page 45](#))

	<p><b>⚠️ WARNING</b></p>
	<p><b>Risk of injury due to accidental actuation of the clamping force block during assembly and connection.</b></p> <ul style="list-style-type: none"> <li>Make sure the power supply for the clamping block is off during assembly and connection.</li> <li>Perform maintenance, modifications, or installations outside of the danger zone.</li> </ul>

	<p><b>⚠️ WARNING</b></p>
	<p><b>Risk of injury from clamping block or chuck jaws falling during transport, installation or removal!</b></p> <ul style="list-style-type: none"> <li>Make sure the clamping block and chuck jaws do not fall during transport, installation or removal.</li> <li>Use a crane and/or a transport truck for transportation.</li> <li>Only install the clamping block on machines with the appropriate connection dimensions.</li> </ul>

### 5.1 Assembly of the Clamping Block on the machine table

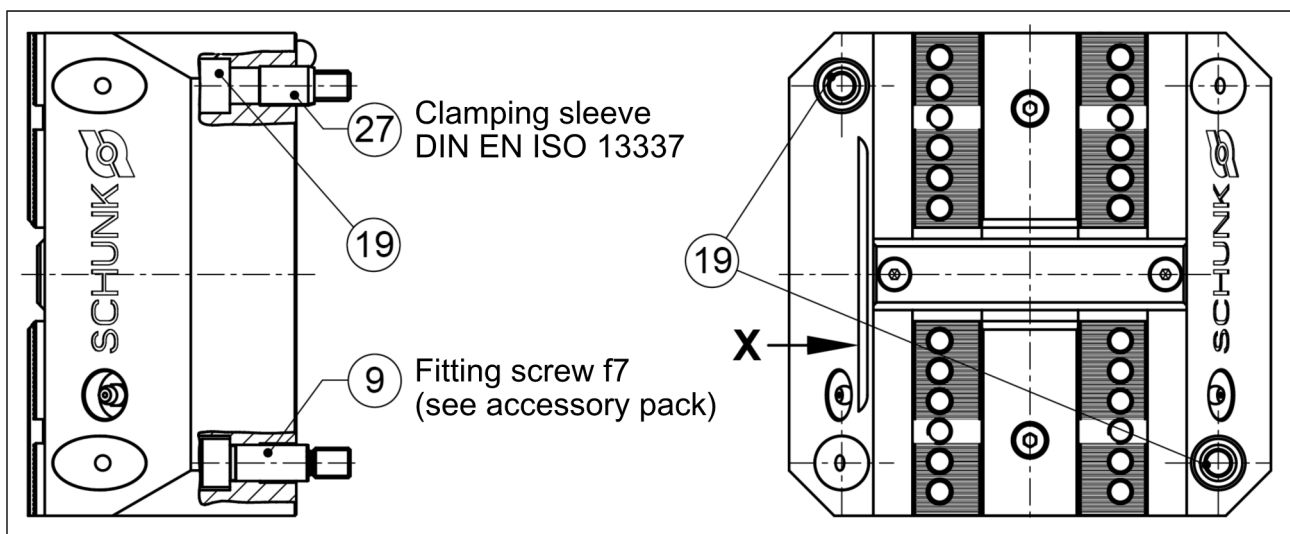

Assembly of the Clamping Block

**NOTE**

- For vertical installation, the opening of the coolant drain (item 13) must always face downwards
- Surface "X" is parallel to the guideway of the base jaws (item 2) so the clamping block can be aligned on the machine table.

**Assembly with clamping sleeves:**

Mount the clamping block on the machine table together with clamping sleeves (item 27) and screws (item 19).

**Assembly with fitting screws:**

There are two fittings in the housing (item 1) that, along with the optional fitting screws (item 9), are used to center the clamping block on the machine table with repeat accuracy. Do not realign the clamping block after removing it from the machine table (e.g., after replacing the seals). When using fitting screws (item 9), use them instead of the clamping sleeves (item 27) and the two corresponding screws (item 19).

**5.2 Connecting the clamping block**

**Make sure the power supply is off when connecting the clamping block. Observe the "Basic safety notes" and the hydraulic wiring diagram ([5.3, Page 23](#)).**

**The hydraulic screw fittings must be assembled in accordance with the installation conditions recommended by the manufacturer.**

**For the operation of the clamping block, the hydraulic oil must correspond to a viscosity of 46 mm/s, and be filtered.** Hydraulic oil that is not prepared can wear out the clamping block prematurely and lead to malfunctions.



**CAUTION**

**Risk of work piece losses and damage to the automated system due to loss of oil pressure caused by damaged hydraulic lines.**

Always make sure the connections are tight, and protect the hydraulic hoses or lines against hot chips and falling parts with suitable protection covers.

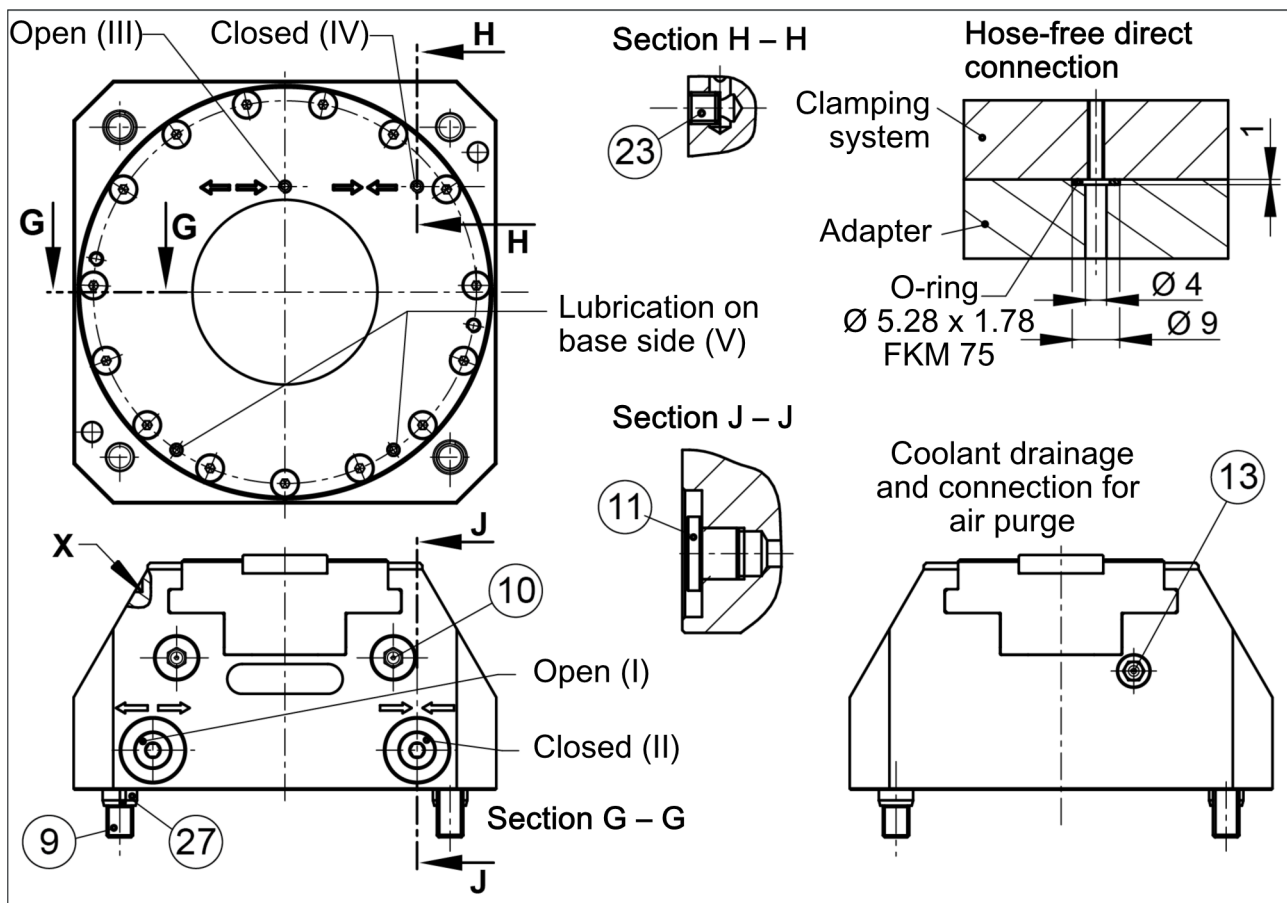

Connecting the clamping block

The clamping force block has four hydraulic connections: **I, II, III, IV.**

Two connections for OPEN (**I** and **III**) and two connections for CLOSE (**II** and **IV**).

Which of the two hydraulic connections has to be opened for actuation depends on the specific application:

- Connection **I** and **II** for operation with external hydraulic pipes or hose lines.  
The thread for the hydraulic fitting – on the front of the housing (item 1) – is G $\frac{1}{8}$ " for all clamping force blocks.
- Connection **III** and **IV** in the base for hose-free direct connection in the machine table.

**The threads for hose-free, direct connection are not designed for hydraulic screw fittings.**

NOTE:

All four hydraulic connections come sealed on delivery of the clamping force block. The connections on the base are sealed with set-screws (item 23) and those on the front with locking screws for hydraulics (item 11).

### Hose-free direct connection

If the clamping system is connected via hose-free direct connections in the machine table, the base side openings in the cover (item 5) must be sealed.

Do not open the front connections (**I, II**) on the clamping system, alternatively seal them airtight with locking screws for hydraulics (G $\frac{1}{8}$ ").

The hydraulic pressure input and output supply to the connections (**III, IV**) is sealed via an O-ring, which is inserted in an O-ring seat in the tabletop.

- The dimensions for the production of the axial-sealing O-ring seat are:  $\varnothing 9^{+0.1} \times 1.1^{+0.05}$ .

Before assembling the clamping block on the table top, the Torx set-screws (item 23) must be removed from the cover (item 5) of the clamping block.

#### NOTE:

When joining together, make sure that the feed-throughs of the input and output feed for the hydraulic pressure supply to the clamping force block and tabletop are precisely aligned above one another, and the O-rings for sealing are inserted.

- Screw the clamping force block to the machine table, observing the tightening torques ([☞ 4, Page 18](#)). The assembly parts (screws, clamping sleeves, O-rings) are included in the accessory pack. The different mounting variations of the clamping force block are described in the chapter on "Mounting the clamping force block on the machine table" ([☞ 5.1, Page 19](#)).
- Before commissioning the clamping block, make sure that the frontal hydraulic connections are properly sealed.

### Automatic lubrication

The clamping block has two more base connections (**V**) for direct lubrication through the machine table. At the time of delivery, these connections are sealed with set-screws (item 23 and item 24).

If required, the clamping block can be automatically supplied with grease through these connections. A bore hole provides the guideway of both base jaws with grease. That is why both lines must be connected. The Torx set-screws (item 23 and item 24) also need to be removed from the cover (item 5). The automatic supply of lubricant should take place intermittently.

Sealing is carried out in each case via an O-ring, which is inserted in an O-ring seat in the table top.

- The dimensions for the production of the axial-sealing O-ring seat are:  $\varnothing 9^{+0.1} \times 1.1^{+0.05}$ .

The recommended O-rings for sealing the supply lines  $\varnothing 5.28 \times 1.78$  FKM 75 are not included in the clamping force block's scope of delivery.

### 5.3 Hydraulic circuit diagram

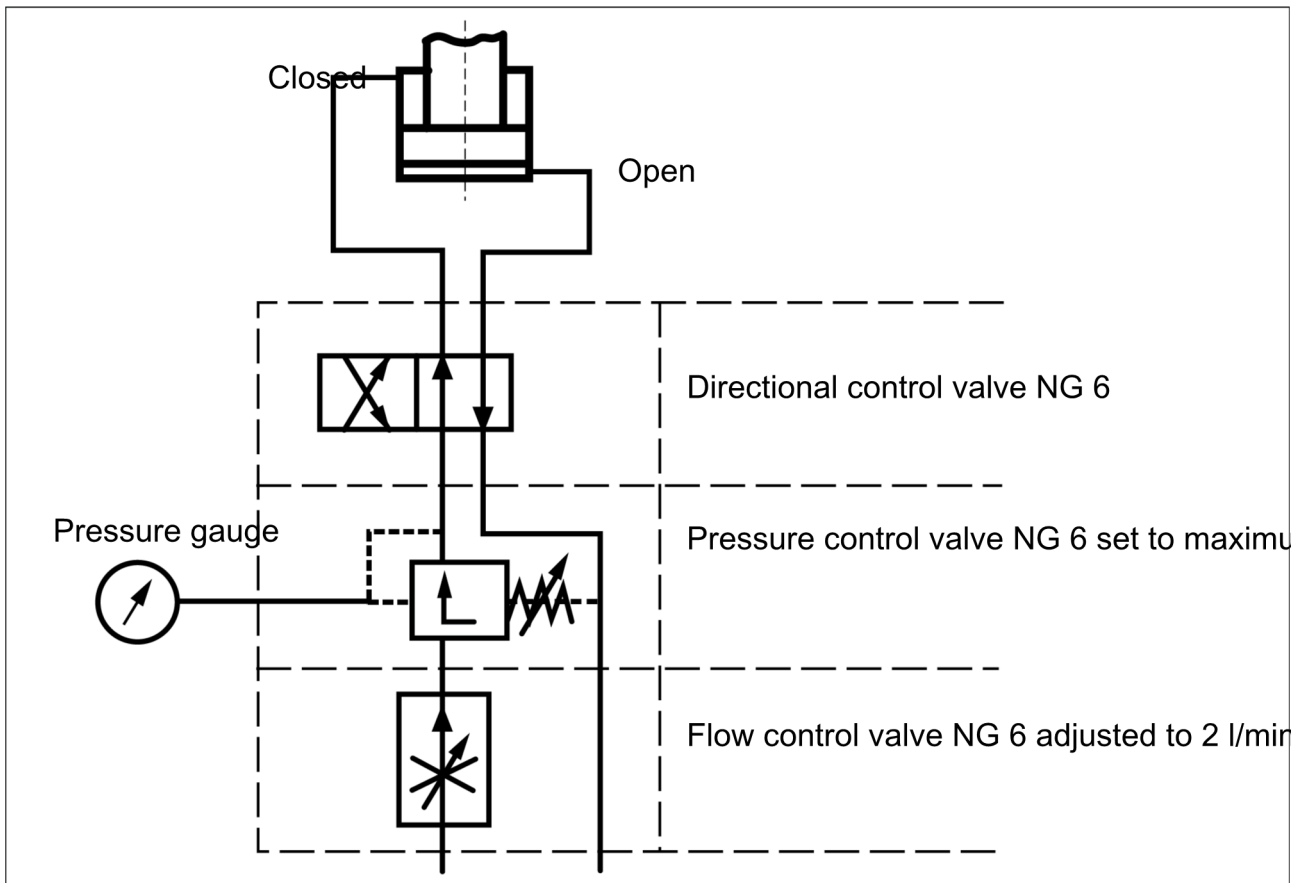

Hydraulic circuit diagram

## 6 Control of proper function

- Test to make sure the TANDEM clamping block is functioning properly before putting it into operation. Make sure there are no leaks in the line system.
- If the clamping system is involved in a collision, it must be tested to see if it is still functioning properly before using it again. Only use original SCHUNK spare parts when replacing damaged parts.
- Visually inspect the clamping block at least once per shift for visible damage and defects.
- Renew the chuck jaw mounting bolts if there are signs of wear or damage. Only use screws with a quality of 12.9.



## 7 Troubleshooting

### Clamping block's chucks jaws don't move

Possible cause	Remedial measures
Oil supply is interrupted or not enough pressure	Check the hydraulic supply
Connections incorrectly connected	Check connections ( <a href="#">☞ 5.2, Page 20</a> )
Hydraulic connections that are not in use are not closed	Check connections and close
Hydraulic connections that are in use are closed	Check connections and open
Screw breakage on the chuck piston or piston rod is broken (e.g. due to overload)	Disassemble clamping block and replace damaged parts ( <a href="#">☞ 8.1, Page 26</a> ) or send to SCHUNK for repair

### The clamping block does not make a complete stroke

Possible cause	Remedial measures
Chips or dirt between the covering strip and base jaws	Unscrew the covering strip (item 7) and remove chips and dirt

### The clamping force is getting weaker

Possible cause	Remedial measures
The clamping block is not tightly sealed	Check connection and sealing screw fittings and reseal or replace
Seals are damaged	Disassemble clamping block ( <a href="#">☞ 8.1, Page 26</a> ) and replace all the seals (see sealing kit list ( <a href="#">☞ 9.1, Page 33</a> ))
Inadequate lubrication	Lubricate the lubrication nipples with LINO MAX 200 ( <a href="#">☞ 8, Page 26</a> )

### The clamping block is jerky

Possible cause	Remedial measures
Guide rollers on the sliding surfaces are not greased	See chapter ( <a href="#">☞ 8, Page 26</a> )

## 8 Maintenance and care

To ensure the clamping block operates perfectly, the following instructions are to be observed:

- Make sure the borehole for coolant drainage is clear at all times!
- Lubricate the guides on the two front or the two side lubricating nipples with LINOMAX 200 depending on load, but at least once per month or every 10,000 clamping operations. Make sure the chuck jaws are in the open position.
- Upgrade the base jaws and the chuck piston at least every three months or more often if necessary (see chapter "Disassembling and assembling the clamping force block", point 1–8 ([☞ 8.1, Page 26](#))). Clean the housing, base jaws and chuck piston, and lubricate all the guides (housing, base jaws, chuck piston) with LINOMAX 200. Reassemble everything and relubricate the two front or two side lubricating nipples with LINOMAX 200.

(Product information for LINOMAX 200 can be requested from SCHUNK ).

	<b>⚠ CAUTION</b>
	<b>Allergic reactions due to grease in contact with skin!</b> Wear gloves.

### IMPORTANT!

Please regularly check the clamping device for tightness by applying a clamping force tester over a longer period of time (> 10 min.). The clamping force should not drop during this period. Please adjust the inspection interval to the operating conditions of the clamping device, however, we do recommend conducting a check every 5,000 clamping cycles at the latest

### 8.1 Disassembly and assembly the clamping block

The item numbers specified for the corresponding individual components relate to chapter drawings. ([☞ 10, Page 45](#))

**NOTE**

The base jaws (items 2, 31), chuck piston (item 3) and housing (item 1) are precisely coordinated. These parts cannot be replaced individually. To replace these parts, ship the whole clamping block with a repair order to SCHUNK.

When replacing wearing parts (e.g. seals - [☞ 9.1, Page 33](#)), adhere to the following order:

- 1 Apply hydraulic pressure to the clamping block until the jaws are in the OPEN position.
- 2 Remove the pressure line or shut off the hydraulic system and secure against unauthorized reactivation.
- 3 Remove the covering strip (item 7) and the guide strips (item 6).
- 4 Remove the cylindrical screw (item 14) from the chuck piston.  
To ensure that the piston does not turn when loosening the screw, it may be necessary to move the clamping block to the OPEN jaw position for further disassembly. Size **KSH-LH plus 250** must be moved to position CLOSED. To do this, reconnect the clamping block to the hydraulic system and set the clamping block to position OPEN or CLOSED with the prescribed pressure and loosen the screw. Do not remove the pressure line until the screw (item 14) has been removed.
- 5 Pull the plugs (item 8) out of the housing (item 1).
- 6 Loosen the screws (items 9, 19) and disassemble the clamping system from the machine table.
- 7 To pull-off the chuck piston (item 3) for size 64 screw in one M6 x > 25 screw in the center bore, for size 100, screw in one M10 x > 25 screw in the center bore, for sizes 140 and 160, screw one M12 x 25 screw in the center bore, for size 250, screw in two M6 x 25 screws in the lateral threaded holes.

In addition, for the variant KSH-F plus:

- Remove the screw (item 32) between the base jaw (item 31) and housing (item 1).
- Remove the positioning bolt (item 29) between base jaw (item 31) and housing (item 1). Also, screw an M3 screw for size 64, an M5 screw for sizes 100, 140 and 160 or an M6 screw for size 250 in the thread of the positioning bolt (item 29).
- Pull the base jaw (item 31) out of the housing (item 1).

- 8 Pull the base jaws (item 2) out of the housing (item 1).
- 9 Before pulling off the cover (item 5), all the screws (item 21) need to be removed. To pull off the cover (item 5), screw two screws into the outer threaded holes:  
for size 64, two M3 x > 25 screws,  
for size 100, two M3 x > 25 screws,  
for size 140, two M4 x > 25 screws,  
for size 160 and 250, two M5 x > 25 screws.
- 10 Remove the seals (items 17, 22, 41).
- 11 Shim the clamping block such that the cylinder piston (item 4) can be pushed out.
- 12 Remove the two-part seal (item 20) from the housing (item 1).
- 13 For signs of wear or damage, remove the two-part seal (item 12) from the cylinder piston (item 4).  
If no signs of damage or wear are detected, the seal should remain fitted, as special tools are required for reassembly.
- 14 Clean all the parts thoroughly and check for damage and wear.  
**Replace damaged and worn parts with original SCHUNK spare parts.**
- 15 Grease the new seal (item 15) with Renolit HLT 2 or an equivalent grease. Carefully install the seal, it must not be damaged.
- 16 Disassemble the two-part seal (item 20) and grease with Renolit HLT 2 or an equivalent grease.
  - Insert the O-ring of the seal (item 20) into the groove of the housing (item 1). **Do not twist!**
  - Press the sealing ring together into a kidney shape. Ensure there are no sharp-edged kinks.Place the sealing ring in its compressed form into the groove, then press the already inserted O-ring downwards on all sides.
- 17 Grease the two-part seal (item 12) with Renolit HLT 2 or an equivalent grease. Carefully install the seal (see Mounting the Piston Seal ([👉 8.2, Page 30](#))).
- 18 Grease the sliding surfaces of the cylinder and piston with Renolit HLT 2 or equivalent grease.
- 19 Insert the cylinder piston (item 4) including mounted seal (item 12) into the cylinder of the cover (item 5).

- 20 When pressing in the cylinder piston (item 4), the seal (item 12) must sit snugly in the cylinder and must not be damaged during assembly.
- 21 Lubricate the new seals (items 17, 22, 41) with Renolit HLT 2 or an equivalent grease.
- 22 Place the O-rings (item 22) and (item 41) in the housing (item 1); and the O-ring (item 17) in the cover (item 5). Carefully install the new seals, they must not be damaged.
- 23 Insert the cover (item 5) into the housing (item 1), making sure that the openings for the hydraulic feed-throughs are aligned.
- 24 Screw the cover (item 5) onto the housing (item 1). Use a torque wrench ([👉 4, Page 18](#)).
- 25 If using clamping sleeves (item 27) for centering, insert these into the housing (item 1) now.
- 26 Grease the sliding surfaces of the housing (item 1), base jaws (item 2) and chuck piston (item 3) with LINO MAX 200 grease.
- 27 Assemble the base jaws (item 2) and the chuck piston (item 3). Be sure to observe the installation position for the base jaws and the chuck piston.  
In addition, for variant KSH-F plus:
  - Mount base jaw (item 31) in the housing (item 1).
  - Mount the positioning bolt (item 29) between base jaw (item 31) and housing (item 1).
  - Screw in the screw (item 32) between the base jaw (item 31) and the housing (item 1).
- 28 Connect the hydraulic clamping force block to the air supply with hydraulic oil before operation and put the jaws in the CLOSED position. For this purpose, a blow gun for compressed air with a rubber nozzle can be used.
- 29 Screw down the chuck piston (item 3) and cylinder piston (item 4). Tighten the screw (item 14) with a torque wrench ([👉 4, Page 18](#)).  
To ensure that the piston does not turn when loosening the screw, it may be necessary to move the clamping block to the OPEN jaw position for further disassembly. To do this, reconnect the clamping block to the hydraulic system and set it to OPEN position with the prescribed pressure. Do not remove the pressure line until the screw (pos. 14) has been tightened to the prescribed torque.
- 30 Fasten the guide strips (item 6) and the covering strip (item 7).

31 Testing the leakage and tightness of the hydraulic system  
[\(↪ 8.3, Page 31\).](#)

**8.2 Assembling the piston seal**

To assemble the seal (item 12), a multi-part assembly tool is required. If no assembly tool is available, repair work on the TANDEM clamping block should be carried out by SCHUNK.

**1. Assembly**

- Disassemble the two-part seal (item 12) and grease with Renolit HLT 2 or an equivalent grease.
- Pull the O-ring of the seal (item 12) over the cylinder piston (item 4) and into the groove. (Do not stretch or tear the O-Ring.)
- Stretch the sealing ring with an expansion sleeve over the cone sleeve and slide over the cylinder piston and the O-ring that was previously inserted into the groove.

**2. Calibration**

After sliding it over, the Turcon-ring snaps into the groove. However, assembly is still not complete. The stretched ring needs to be returned to its original shape with a calibration sleeve.

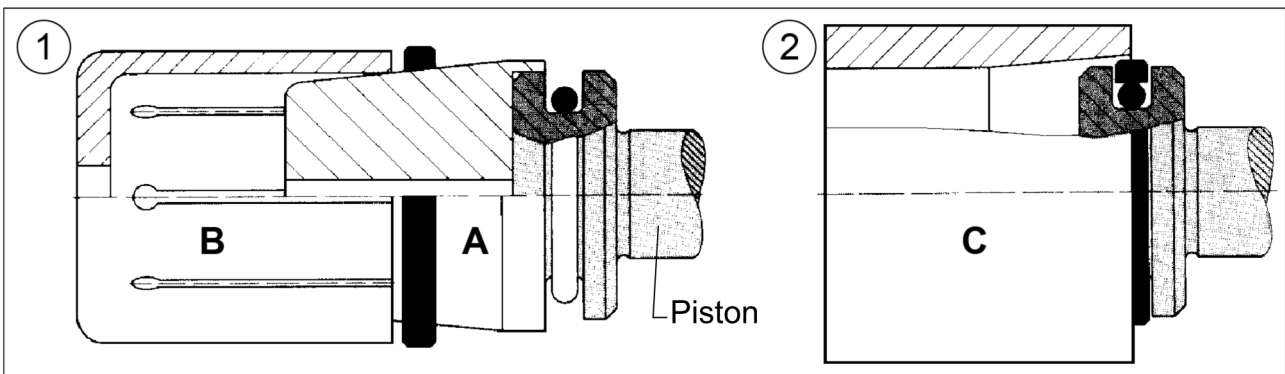

Assembling the piston seal

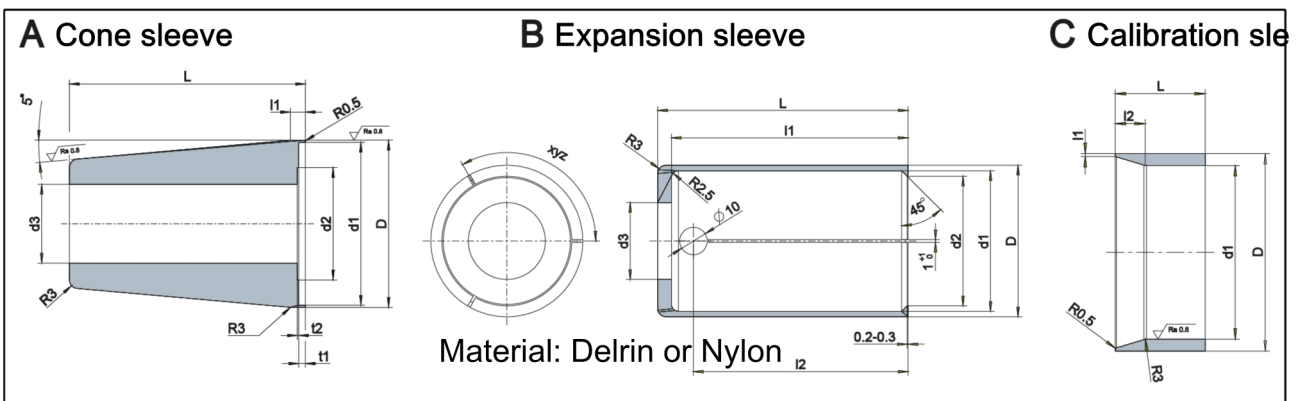

Assembly tools for the piston seal

A cone sleeve			Material: steel						
KSH plus	Piston $\varnothing$	D	$d_1^{+0.15}$	$d_2$	$d_3$	L	$l_1$	$t_1^{+0.3}$	$t_2$
64	21	22.5	21	13	5	70	5	2	0.5
100	35	36.5	35	22	17	75	5.7	2.7	0.5
140	50	51.5	50	37	25	80	5	2	0.5
160	58	59.5	58	40	28	85	5.4	2.4	0.5
250	120	121.5	120	60	58	100	11.5	8.5	0.5

B expansion sleeve			Material: POM, Nylon® or similar						
KSH plus	Piston $\varnothing$	D	$d_1$	$d_2$	$d_3$	L	$l_1$	$l_2$	xyz
64	21	20.37	16.37	12.37	5	76	71	63	3 x 120°
100	35	34.64	30.64	26.64	17	81	76	68	3 x 120°
140	50	48.94	44.94	40.94	25	86	81	73	4 x 90°
160	58	55.22	51.22	47.22	28	91	86	78	4 x 90°
250	120	115.54	111.54	107.54	58	106	101	93	6 x 60°

C calibration sleeve		Material: steel				
KSH plus	Piston $\varnothing$	D	$d_1^{+0.1}$	L	$l_1$	$l_2^{\pm 1}$
64	21	29.05	21.05	30	1	10
100	35	43.05	35.05	30	1	10
140	50	58.05	50.05	30	1	10
160	58	66.05	58.05	30	1	10
250	120	128.05	120.05	30	1	10

### 8.3 Testing the leakage and tightness of the hydraulic system

The TANDEM clamping block is hydraulically actuated. The clamping force can be regulated via the initiated hydraulic pressure.

- To test the leakage and tightness, the following components are needed: Hydraulic unit or manually actuated hydraulic pump, pressure gauge, shut-off valve and quick-change couplings.
- Test the tightness of the clamping system in the OPEN and CLOSED positions.

Connect the components for the leakage and tightness test on the clamping system in the following order:

- 1 Adjust the hydraulic unit with pressure gauge and shut-off valve to minimum pressure.
- 2 Connect the hydraulic screw fittings to the **frontal** OPEN and CLOSED connections.
- 3 Link the energy line and hydraulic coupling to the hydraulic screw fittings.



**! WARNING**

**Risk of injury due to leaking of high pressure oil**

When testing the leakage and tightness, the hydraulic connections on the base side must be closed!

When using a hose-free direct connection, the clamping system must stay firmly screwed to the machine table!

The leakage and tightness test is to be performed in the following order:

- 1 Actuate the clamping block with reduced hydraulic pressure. Check the clamping block for free movement by opening and closing the jaws several times.
- 2 Check the clamping block with the maximum permissible hydraulic pressure.
- 3 Inspect the outside of the TANDEM clamping block for visible signs of damage and oil leakage.

**Measures in the event of a leaking hydraulic system**

If the clamping system is leaking, check the screw fittings first.

Leaking screw fittings must be sealed.

If the screw fittings are sealed, check the seals in the clamping block and replace if necessary ([↩ 8.1, Page 26](#)).



## 9 Sealing kits, accessory packs and parts lists

When ordering spare parts, the type, size and, if possible, the serial number of the clamping block must always be stated to avoid delivery mistakes.

**Seals, sealing elements, screw connections, springs, bearings, screws, wiper bars and parts that come into contact with the workpiece are not covered by the warranty.**

### 9.1 Sealing kit lists

#### KSH plus 64, KSH-LH plus 64, KSH-F plus 64 (ID 0405139)

Item	Designation	Quantity
12	Turcon Glyd Ring	1
15	Sealing ring	1
17	O-ring	1
18	O-ring	4
20	Turcon Glyd Ring	1
22	O-ring	4
54	O-ring	4

#### KSH plus 100, KSH-LH plus 100, KSH-F plus 100 (ID 0405239)

Item	Designation	Quantity
12	Turcon Glyd Ring	1
15	Sealing ring	1
17	O-ring	1
18	O-ring	4
20	Turcon Glyd Ring	1
22	O-ring	2
26	O-ring	2
54	O-ring	4

#### KSH plus 140, KSH-LH plus 140, KSH-F plus 140 (ID 1352793)

Item	Designation	Quantity
12	Turcon Glyd Ring	1
15	Sealing ring	1
17	O-ring	1
18	O-ring	4

## Sealing kits, accessory packs and parts lists

Item	Designation	Quantity
20	Turcon Glyd Ring	1
22	O-ring	4
54	O-ring	4

### **KSH plus 160, KSH-LH plus 160, KSH-F plus 160 (ID 0405339)**

Item	Designation	Quantity
12	Turcon Glyd Ring	1
15	Sealing ring	1
17	O-ring	1
18	O-ring	4
20	Turcon Glyd Ring	1
22	O-ring	2
41	O-ring	2
54	O-ring	4

### **KSH plus 250, KSH-LH plus 250, KSH-F plus 250 (ID 0405559)**

Item	Designation	Quantity
12	Turcon Glyd Ring	1
15	Sealing ring	1
17	O-ring	1
18	O-ring	4
20	Turcon Glyd Ring	1
54	O-ring	4

**Wear parts – replacement recommended during maintenance**

**The sealing kit can only be ordered as a complete kit.**

## **9.2 Accessory packs**

### **KSH plus 64, KSH-LH plus 64, KSH-F plus 64 (ID 8507916)**

Item	Designation	Quantity
8	Plug	4
9	Fitting screw	2
18	O-ring	4
19	Screw	4
27	Clamping sleeve	2
51	Screw	8

Item	Designation	Quantity
54	O-ring	4
55	O-ring	2

**KSH plus 100, KSH-LH plus 100, KSH-F plus 100**(ID 8507916)

Item	Designation	Quantity
8	Plug	4
9	Fitting screw	2
18	O-ring	4
19	Screw	4
27	Clamping sleeve	2
51	Screw	8
54	O-ring	4

**KSH plus 140, KSH-LH plus 140, KSH-F plus 140**(ID 1346788)

Item	Designation	Quantity
8	Plug	4
9	Fitting screw	2
18	O-ring	4
19	Screw	4
27	Clamping sleeve	2
51	Screw	8
54	O-ring	4

**KSH plus 160, KSH-LH plus 160, KSH-F plus 160**(ID 8507917)

Item	Designation	Quantity
8	Plug	4
9	Fitting screw	2
18	O-ring	4
19	Screw	4
27	Clamping sleeve	2
51	Screw	8
54	O-ring	4

**KSH plus 250, KSH-LH plus 250, KSH-F plus 250**(ID 8507918)

Item	Designation	Quantity
8	Plug	4
9	Fitting screw	2

Item	Designation	Quantity
18	O-ring	4
19	Screw	4
27	Clamping sleeve	2
51	Screw	8
52	T-handle for KSP	2
53	Set-screw	2
54	O-ring	4

### 9.3 Part lists

#### KSH plus 64(ID 0405130), KSH-LH plus 64(ID 1313057)

Item	Designation	Quantity
1*	Body	1
2*	Base jaw	2
3*	Piston	1
4	Cylinder piston	1
5	Cover	1
6	Guide strip	2
7	Covering strip	1
8***	Plug	4
9***	Fitting screw	2
10	Funnel lubrication nipple	4
11	Locking screw	2
12**	Turcon Glyd Ring	1
13	Sound absorber	1
14	Screw	1
15**	Sealing ring	1
16	Screw	2
17**	O-ring	1
18***	O-ring	4
19***	Screw	4
20**	Turcon Glyd Ring	1
21	Countersunk screw	8
22**	O-ring	4
23	Set-screw	8

Item	Designation	Quantity
25	Countersunk screw	2
27***	Clamping sleeve	2

**KSH-F plus 64(ID 0405140)**

Item	Designation	Quantity
1*	Body	1
2*	Base jaw	1
3*	Piston	1
4	Cylinder piston	1
5	Cover	1
6	Guide strip	1
7	Covering strip	1
8***	Plug	4
9***	Fitting screw	2
10	Funnel lubrication nipple	4
11	Locking screw	2
12**	Turcon Glyd Ring	1
13	Sound absorber	1
14	Screw	1
15**	Sealing ring	1
16	Screw	1
17**	O-ring	1
18***	O-ring	4
19***	Screw	4
20**	Turcon Glyd Ring	1
21	Countersunk screw	8
22**	O-ring	4
23	Set-screw	8
25	Countersunk screw	2
27***	Clamping sleeve	2
29	Socket pin	1
30	Screw	1
31*	Base jaw	1
32	Screw	1
33	Guide strip	1

**KSH plus 100**(ID 0405230) , **KSH-LH plus 100**(ID 0405250)

Item	Designation	Quantity
1*	Body	1
2*	Base jaw	2
3*	Piston	1
4	Cylinder piston	1
5	Cover	1
6	Guide strip	2
7	Covering strip	1
8***	Plug	4
9***	Fitting screw	2
10	Funnel lubrication nipple	4
11	Locking screw	2
12**	Turcon Glyd Ring	1
13	Sound absorber	1
14	Screw	1
15**	Sealing ring	1
16	Screw	2
17**	O-ring	1
18***	O-ring	4
19***	Screw	4
20**	Turcon Glyd Ring	1
21	Countersunk screw	10
22**	O-ring	2
23	Set-screw	5
24	Set-screw	2
25	Countersunk screw	2
26	O-ring	2
27***	Clamping sleeve	2

**KSH-F plus 100**(ID 0405240)

Item	Designation	Quantity
1*	Body	1
2*	Base jaw	1
3*	Piston	1
4	Cylinder piston	1

Item	Designation	Quantity
5	Cover	1
6	Guide strip	2
7	Covering strip	1
8***	Plug	4
9***	Fitting screw	2
10	Funnel lubrication nipple	4
11	Locking screw	2
12**	Turcon Glyd Ring	1
13	Sound absorber	1
14	Screw	1
15**	Sealing ring	1
16	Screw	2
17**	O-ring	1
18***	O-ring	4
19***	Screw	4
20**	Turcon Glyd Ring	1
21	Countersunk screw	10
22**	O-ring	2
23	Set-screw	5
24	Set-screw	2
25	Countersunk screw	2
26	O-ring	2
27***	Clamping sleeve	2
28	Spherical washer	1
29	Socket pin	1
30	Screw	1
31*	Base jaw	1
32	Screw	1

**KSH plus 140(ID 1330214), KSH-LH plus 140(ID 1330216)**

Item	Designation	Quantity
1*	Body	1
2*	Base jaw	2
3*	Piston	1
4	Cylinder piston	1

## Sealing kits, accessory packs and parts lists

Item	Designation	Quantity
5	Cover	1
6	Guide strip	2
7	Covering strip	1
8***	Plug	4
9***	Fitting screw	2
10	Funnel lubrication nipple	4
11	Locking screw	2
12**	Turcon Glyd Ring	1
13	Sound absorber	1
14	Screw	1
15**	Sealing ring	1
16	Screw	2
17**	O-ring	1
18***	O-ring	4
19***	Screw	4
20**	Turcon Glyd Ring	1
21	Countersunk screw	15
22**	Flat gasket	4
23	Set-screw	5
25	Countersunk screw	2
27***	Clamping sleeve	2

### KSH-F plus 140(ID 1330218)

Item	Designation	Quantity
1*	Body	1
2*	Base jaw	1
3*	Piston	1
4	Cylinder piston	1
5	Cover	1
6	Guide strip	1
7	Covering strip	1
8***	Plug	4
9***	Fitting screw	2
10	Funnel lubrication nipple	4
11	Locking screw	2



Item	Designation	Quantity
12**	Turcon Glyd Ring	1
13	Sound absorber	1
14	Screw	1
15**	Sealing ring	1
16	Screw	1
17**	O-ring	1
18***	O-ring	4
19***	Screw	4
20**	Turcon Glyd Ring	1
21	Countersunk screw	15
22**	Flat gasket	4
23	Set-screw	8
24	Set-screw	2
25	Countersunk screw	2
27***	Clamping sleeve	2
28	Spherical washer	1
29	Socket pin	1
30	Screw	1
31*	Base jaw	1
32	Screw	1

**KSH plus 160(ID 0405330), KSH-LH plus 160(ID 0405350)**

Item	Designation	Quantity
1*	Body	1
2*	Base jaw	2
3*	Piston	1
4	Cylinder piston	1
5	Cover	1
6	Guide strip	2
7	Covering strip	1
8***	Plug	4
9***	Fitting screw	2
10	Funnel lubrication nipple	4
11	Locking screw	2
12**	Turcon Glyd Ring	1

## Sealing kits, accessory packs and parts lists

Item	Designation	Quantity
13	Sound absorber	1
14	Screw	1
15**	Sealing ring	1
16	Screw	2
17**	O-ring	1
18***	O-ring	4
19***	Screw	4
20**	Turcon Glyd Ring	1
21	Countersunk screw	15
22**	O-ring	2
23	Set-screw	4
24	O-ring	2
25	Countersunk screw	2
26	Set-screw	4
27***	Clamping sleeve	2
41**	O-ring	2

### KSH-F plus 160(ID 0405340)

Item	Designation	Quantity
1*	Body	1
2*	Base jaw	1
3*	Piston	1
4	Cylinder piston	1
5	Cover	1
6	Guide strip	2
7	Covering strip	1
8***	Plug	4
9***	Fitting screw	2
10	Funnel lubrication nipple	4
11	Locking screw	2
12**	Turcon Glyd Ring	1
13	Sound absorber	1
14	Screw	1
15**	Sealing ring	1
16	Screw	1

Item	Designation	Quantity
17**	O-ring	1
18***	O-ring	4
19***	Screw	4
20**	Turcon Glyd Ring	1
21	Countersunk screw	15
22**	Flat gasket	2
23	Set-screw	4
24	O-ring	2
25	Countersunk screw	2
26	Set-screw	4
27***	Clamping sleeve	2
28	Spherical washer	1
29	Socket pin	1
30	Screw	1
31*	Base jaw	1
32	Screw	1
41**	O-ring	2

**KSH-LH plus 250(ID 0405550)**

Item	Designation	Quantity
1*	Body	1
2*	Base jaw	2
3*	Piston	1
4	Cylinder piston	1
5	Cover	1
6	Guide strip	2
7	Covering strip	1
8***	Plug	4
9***	Fitting screw	2
10	Funnel lubrication nipple	4
11	Locking screw	2
12**	Turcon Glyd Ring	1
13	Sound absorber	1
14	Screw	1
15**	Sealing ring	1

## Sealing kits, accessory packs and parts lists

Item	Designation	Quantity
16	Screw	2
17**	O-ring	1
18***	O-ring	4
19***	Screw	4
20**	Turcon Glyd Ring	1
23	Set-screw	2
24	Set-screw	2
25	Countersunk screw	2
27***	Clamping sleeve	2

\* Individual components are precisely coordinated and cannot not be replaced by the customer.

\*\* See seal kit list – parts cannot be ordered individually

\*\*\* Included in accessory kit

## 10 Assembly drawings

### 10.1 KSH plus, KSH-LH plus

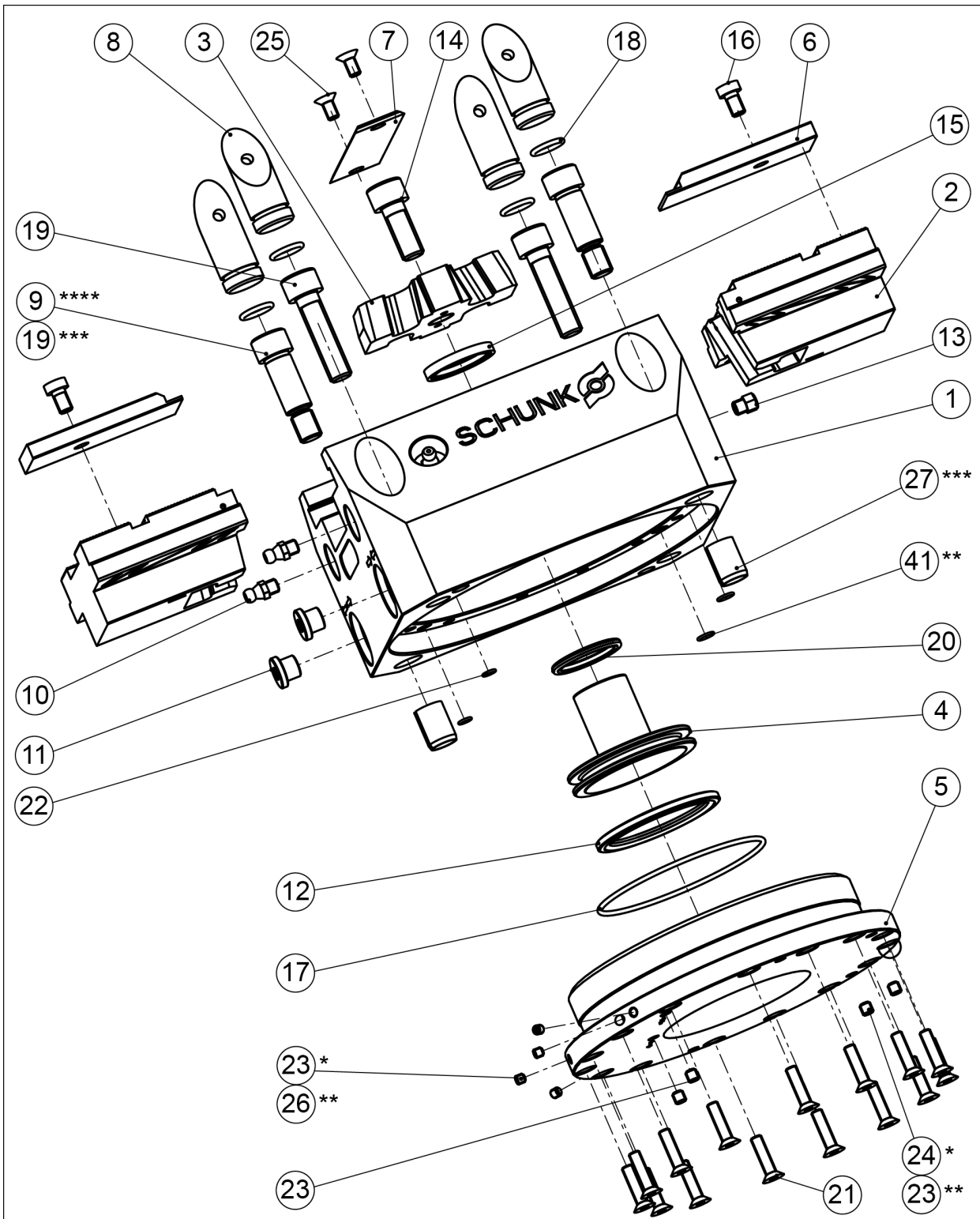

*	for size 100	**	for sizes 140/160/250
***	Centering with clamping sleeves	****	Centering with fitting screws

10.2 KSH-F plus

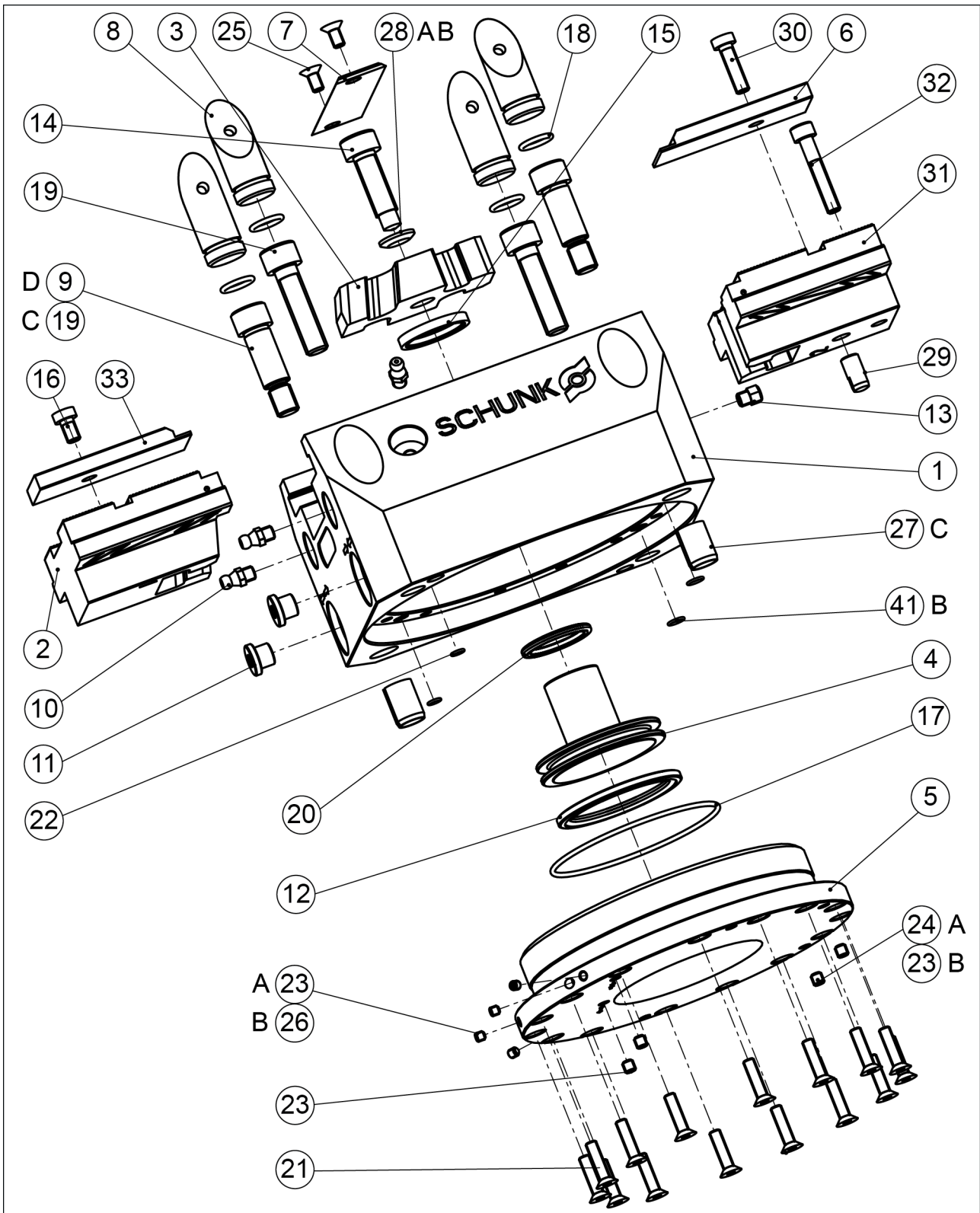

A	for size 100	B	for sizes 140/160
C	Centering with clamping sleeves	D	Centering with fitting screws

## 11 Translation of the original declaration of incorporation

in terms of the Directive 2006/42/EG, Annex II, Part 1.B of the European Parliament and of the Council on machinery.

Manufacturer/ Distributor H.-D. SCHUNK GmbH & Co. Spanntechnik KG  
Lothringer Str. 23  
D-88512 Mengen

We hereby declare that on the date of the declaration the following partly completed machine complied with all basic safety and health regulations found in the directive 2006/42/EC of the European Parliament and of the Council on machinery. The declaration is rendered invalid if modifications are made to the product.

Product designation: Hydraulic TANDEM clamping force block  
KSH plus 64; KSH-Z plus 64; KSH plus 100; KSH-Z plus 100; KSH plus 140; KSH-Z plus 140; KSH plus 160; KSH-Z plus 160; KSH-LH plus 64; KSH-LH-Z plus 64; KSH-LH plus 100; KSH-LH-Z plus 100; KSH-LH plus 140; KSH-LH-Z plus 140; KSH-LH plus 160; KSH-LH-Z plus 160; KSH-LH plus 250; KSH-LH-Z plus 250; KSH-F plus 64; KSH-F-Z plus 64; KSH-F plus 100; KSH-F-Z plus 100; KSH-F plus 140; KSH-F-Z plus 140; KSH-F plus 160; KSH-F-Z plus 160

ID number 0405130; 0405132; 0405230; 0405232; 1330214; 1330215; 0405330; 0405332; 1313057; 1313058; 0405250; 0405252; 1330216; 1330217; 0405350; 0405352; 0405550; 0405552; 0405140; 0405142; 0405240; 0405242; 1330218; 1330219; 0405340; 0405342

The partly completed machine may not be put into operation until conformity of the machine into which the partly completed machine is to be installed with the provisions of the Machinery Directive (2006/42/EC) is confirmed.

Applied harmonized standards, especially:

EN ISO 12100:2010 Safety of machinery - General principles for design - Risk assessment and risk reduction

EN ISO 80079-36:2016 Fluid power - General rules and safety requirements for hydraulic systems and their components

Other related technical standards and specifications:

VDI 3035:2008-05 Design of machine tools, production lines and peripheral equipment for the use of metalworking fluids

The manufacturer agrees to forward on demand the relevant technical documentation for the partly completed machinery in electronic form to national authorities.

The relevant technical documentation according to Annex VII, Part B, belonging to the partly completed machinery, has been created.

Person authorized to compile the technical documentation:

Philipp Schröder, Address: see manufacturer's address

*Signature: see original declaration*

Mengen, September 2018

p.p. Philipp Schröder; Head of Engineering Design