

# Assembly and Operating Manual

## MPG

### 2-Finger Parallel Gripper



## Imprint

### Copyright:

This manual is protected by copyright. The author is SCHUNK GmbH & Co. KG. All rights reserved. Any reproduction, processing, distribution (making available to third parties), translation or other usage - even excerpts - of the manual is especially prohibited and requires our written approval.

### Technical changes:

We reserve the right to make alterations for the purpose of technical improvement.

**Document number:** 389213

**Version:** 10.00 | 13/05/2020 | en

© SCHUNK GmbH & Co. KG

All rights reserved.

Dear Customer,

thank you for trusting our products and our family-owned company, the leading technology supplier of robots and production machines.

Our team is always available to answer any questions on this product and other solutions. Ask us questions and challenge us. We will find a solution!

Best regards,

Your SCHUNK team

SCHUNK GmbH & Co. KG  
Clamping and gripping technology

Bahnhofstr. 106 - 134  
D-74348 Lauffen/Neckar

Tel. +49-7133-103-0  
Fax +49-7133-103-2399

info@de.schunk.com  
schunk.com

## Table of Contents

<b>1</b>	<b>General</b> .....	<b>5</b>
1.1	About this manual .....	5
1.1.1	Presentation of Warning Labels .....	5
1.1.2	Applicable documents .....	6
1.1.3	Sizes .....	6
1.1.4	Variants.....	6
1.2	Warranty .....	6
1.3	Scope of delivery .....	6
1.3.1	Accessories pack.....	7
1.4	Accessories .....	7
1.4.1	Seal kit .....	7
<b>2</b>	<b>Basic safety notes</b> .....	<b>8</b>
2.1	Intended use.....	8
2.2	Not intended use.....	8
2.3	Constructional changes .....	8
2.4	Spare parts .....	9
2.5	Gripper fingers .....	9
2.6	Ambient conditions and operating conditions .....	9
2.7	Personnel qualification.....	10
2.8	Personal protective equipment.....	11
2.9	Notes on safe operation .....	11
2.10	Transport .....	12
2.11	Malfunctions.....	12
2.12	Disposal .....	12
2.13	Fundamental dangers.....	13
2.13.1	Protection during handling and assembly .....	13
2.13.2	Protection during commissioning and operation .....	14
2.13.3	Protection against dangerous movements.....	14
2.13.4	Protection against electric shock.....	15
2.14	Notes on particular risks.....	16
<b>3</b>	<b>Technical data</b> .....	<b>18</b>
<b>4</b>	<b>Design and description</b> .....	<b>19</b>
4.1	Configuration.....	19
4.2	Description .....	19
<b>5</b>	<b>Assembly</b> .....	<b>20</b>
5.1	Assembly and connection.....	20

5.2	Connections.....	22
5.2.1	Mechanical connection.....	22
5.2.2	Pneumatic connection.....	24
5.3	Mounting the sensor .....	26
5.3.1	Overview of sensors .....	26
5.3.2	Mounting the inductive proximity switch IN 5 .....	26
5.3.3	Mounting the inductive proximity switch IN 3, IN 40.....	30
5.3.4	Mounting flexible position sensor FPS .....	31
5.3.5	Mounting the object-distance sensor OAS.....	33
<b>6</b>	<b>Troubleshooting .....</b>	<b>34</b>
6.1	Product is not moving.....	34
6.2	Product is not executing the complete stroke .....	34
6.3	Product is opening or closing abruptly .....	34
6.4	Gripping force is dropping.....	35
6.5	Product does not achieve the opening and closing times .....	35
6.6	Compressed air connection is leaking .....	36
<b>7</b>	<b>Maintenance .....</b>	<b>37</b>
7.1	Notes .....	37
7.2	Maintenance intervals.....	37
7.3	Lubricants/Lubrication points.....	38
7.4	Disassembling and assembling .....	38
7.4.1	Variant without gripping force maintenance .....	39
7.4.2	Variant with gripping force maintenance for "O.D. Gripping" .....	40
7.4.3	Variant with maintenance of gripping force (I.D. gripping).....	41
7.5	Tightening torque for screws.....	42
7.6	Drawings.....	42
7.6.1	Size 16-80 .....	43
7.6.2	FPS variant .....	44
<b>8</b>	<b>Translation of original declaration of incorporation .....</b>	<b>45</b>
<b>9</b>	<b>Annex to Declaration of Incorporation.....</b>	<b>46</b>

## 1 General

### 1.1 About this manual

This manual contains important information for a safe and appropriate use of the product.

This manual is an integral part of the product and must be kept accessible for the personnel at all times.

Before starting work, the personnel must have read and understood this operating manual. Prerequisite for safe working is the observance of all safety instructions in this manual.

Illustrations in this manual are provided for basic understanding and may differ from the actual product design.

In addition to these instructions, the documents listed under [Applicable documents](#) [► 6] are applicable.

#### 1.1.1 Presentation of Warning Labels

To make risks clear, the following signal words and symbols are used for safety notes.



#### **⚠ DANGER**

##### **Danger for persons!**

Non-observance will inevitably cause irreversible injury or death.



#### **⚠ WARNING**

##### **Dangers for persons!**

Non-observance can lead to irreversible injury and even death.



#### **⚠ CAUTION**

##### **Dangers for persons!**

Non-observance can cause minor injuries.

#### **CAUTION**

##### **Material damage!**

Information about avoiding material damage.

### 1.1.2 Applicable documents

- General terms of business \*
- Catalog data sheet of the purchased product \*
- Assembly and operating manuals of the accessories \*

The documents marked with an asterisk (\*) can be downloaded on our homepage [schunk.com](http://schunk.com)

### 1.1.3 Sizes

This operating manual applies to the following sizes:

- MPG 16
- MPG 20
- MPG 25
- MPG 32
- MPG 40
- MPG 50
- MPG 64
- MPG 80

### 1.1.4 Variants

This operating manual applies to the following variations:

- MPG without gripping force maintenance
- MPG with gripping force maintenance "O.D. gripping" (AS)
- MPG with gripping force maintenance "I.D. gripping" (IS)
- MPG high-temperature (V/HT)
- MPG-FPS

## 1.2 Warranty

If the product is used as intended, the warranty is valid for 24 months from the ex-works delivery date under the following conditions:

- Observe the specified maintenance and lubrication intervals
- Observe the ambient conditions and operating conditions

Parts touching the workpiece and wear parts are not included in the warranty.

## 1.3 Scope of delivery

The scope of delivery includes

- 2-Finger Parallel-Gripper MPG in the version ordered
- Assembly and Operating Manual
- Accessory pack

### 1.3.1 Accessories pack

Content of the accessory pack:

#### MPG 20:

- 2 x centering sleeves for mounting

#### MPG 25 - 64:

- 2 x centering sleeves for mounting
- 2 x O-rings for hose-free direct connection
- 2 x locking screws for hose connections
- **Only MPG 25:** 2 x set-screws

*ID.-No. of the accessory pack*

Accessory pack for	ID number	
	MPG	MPG High-temperature (HT)
MPG 16	5522713	5522713
MPG 20	5511369	5511369
MPG 25	5510172	395510172
MPG 32 / 40	5510173	395510173
MPG 50 / 64	5510591	395510591

### 1.4 Accessories

A wide range of accessories are available for this product

For information regarding which accessory articles can be used with the corresponding product variants, see catalog data sheet.

#### 1.4.1 Seal kit

*ID.-No. of the seal kit*

Accessory pack for	ID number	
	MPG	MPG High-temperature (HT)
MPG 16	5516929	-
MPG 20	0370865	0370875
MPG 25	0370807	0370876
MPG 32	0370808	0370813
MPG 40	0370809	0370877
MPG 50	0370866	0370878
MPG 64	0370867	0370879
MPG 80	5516930	-

Contents of the sealing kit, [Drawings](#) [▶ 42].

## 2 Basic safety notes

### 2.1 Intended use

The product is designed exclusively for gripping and temporarily holding workpieces or objects.

- The product may only be used within the scope of its technical data, [Technical data](#) [► 18].
- When implementing and operating components in safety-related parts of the control systems, the basic safety principles in accordance with DIN EN ISO 13849-2 apply. The proven safety principles in accordance with DIN EN ISO 13849-2 also apply to categories 1, 2, 3 and 4.
- The product is intended for installation in a machine/system. The applicable guidelines must be observed and complied with.
- The product is intended for industrial and industry-oriented use.
- Appropriate use of the product includes compliance with all instructions in this manual.

### 2.2 Not intended use

It is not intended use if the product is used, for example, as a pressing tool, stamping tool, lifting gear, guide for tools, cutting tool, clamping device or a drilling tool.

- Any utilization that exceeds or differs from the appropriate use is regarded as misuse.

### 2.3 Constructional changes

#### Implementation of structural changes

By conversions, changes, and reworking, e.g. additional threads, holes, or safety devices can impair the functioning or safety of the product or damage it.

- Structural changes should only be made with the written approval of SCHUNK.



## 2.4 Spare parts

### Use of unauthorized spare parts

Using unauthorized spare parts can endanger personnel and damage the product or cause it to malfunction.

- Use only original spare parts or spares authorized by SCHUNK.

## 2.5 Gripper fingers

### Requirements for the gripper fingers

Stored energy within the product creates the risk of serious injuries and significant property damage.

- Arrange the gripper fingers in a way that the product reaches either the position "open" or "closed" in a de-energized state.
- Only exchange the gripper fingers when no residual energy remains in the product.
- Make sure that the product and the top jaws are a sufficient size for the application.

## 2.6 Ambient conditions and operating conditions

### Required ambient conditions and operating conditions

Incorrect ambient and operating conditions can make the product unsafe, leading to the risk of serious injuries, considerable material damage and/or a significant reduction to the product's life span.

- Make sure that the product is used only in the context of its defined application parameters, [Technical data](#) [▶ 18].

## 2.7 Personnel qualification

### Inadequate qualifications of the personnel

If the personnel working with the product is not sufficiently qualified, the result may be serious injuries and significant property damage.

- All work may only be performed by qualified personnel.
- Before working with the product, the personnel must have read and understood the complete assembly and operating manual.
- Observe the national safety regulations and rules and general safety instructions.

The following personal qualifications are necessary for the various activities related to the product:

<b>Trained electrician</b>	Due to their technical training, knowledge and experience, trained electricians are able to work on electrical systems, recognize and avoid possible dangers and know the relevant standards and regulations.
<b>Qualified personnel</b>	Due to its technical training, knowledge and experience, qualified personnel is able to perform the delegated tasks, recognize and avoid possible dangers and knows the relevant standards and regulations.
<b>Instructed person</b>	Instructed persons were instructed by the operator about the delegated tasks and possible dangers due to improper behaviour.
<b>Service personnel of the manufacturer</b>	Due to its technical training, knowledge and experience, service personnel of the manufacturer is able to perform the delegated tasks and to recognize and avoid possible dangers.

## 2.8 Personal protective equipment

### Use of personal protective equipment

Personal protective equipment serves to protect staff against danger which may interfere with their health or safety at work.

- When working on and with the product, observe the occupational health and safety regulations and wear the required personal protective equipment.
- Observe the valid safety and accident prevention regulations.
- Wear protective gloves to guard against sharp edges and corners or rough surfaces.
- Wear heat-resistant protective gloves when handling hot surfaces.
- Wear protective gloves and safety goggles when handling hazardous substances.
- Wear close-fitting protective clothing and also wear long hair in a hairnet when dealing with moving components.

## 2.9 Notes on safe operation

### Incorrect handling of the personnel

Incorrect handling and assembly may impair the product's safety and cause serious injuries and considerable material damage.

- Avoid any manner of working that may interfere with the function and operational safety of the product.
- Use the product as intended.
- Observe the safety notes and assembly instructions.
- Do not expose the product to any corrosive media. This does not apply to products that are designed for special environments.
- Eliminate any malfunction immediately.
- Observe the care and maintenance instructions.
- Observe the current safety, accident prevention and environmental protection regulations regarding the product's application field.

## 2.10 Transport

### Handling during transport

Incorrect handling during transport may impair the product's safety and cause serious injuries and considerable material damage.

- When handling heavy weights, use lifting equipment to lift the product and transport it by appropriate means.
- Secure the product against falling during transportation and handling.
- Stand clear of suspended loads.

## 2.11 Malfunctions

### Behavior in case of malfunctions

- Immediately remove the product from operation and report the malfunction to the responsible departments/persons.
- Order appropriately trained personnel to rectify the malfunction.
- Do not recommission the product until the malfunction has been rectified.
- Test the product after a malfunction to establish whether it still functions properly and no increased risks have arisen.

## 2.12 Disposal

### Handling of disposal

The incorrect handling of disposal may impair the product's safety and cause serious injuries as well as considerable material and environmental harm.

- Follow local regulations on dispatching product components for recycling or proper disposal.

## 2.13 Fundamental dangers

### General

- Observe safety distances.
- Never deactivate safety devices.
- Before commissioning the product, take appropriate protective measures to secure the danger zone.
- Disconnect power sources before installation, modification, maintenance, or calibration. Ensure that no residual energy remains in the system.
- If the energy supply is connected, do not move any parts by hand.
- Do not reach into the open mechanism or movement area of the product during operation.

### 2.13.1 Protection during handling and assembly

#### Incorrect handling and assembly

Incorrect handling and assembly may impair the product's safety and cause serious injuries and considerable material damage.

- Have all work carried out by appropriately qualified personnel.
- For all work, secure the product against accidental operation.
- Observe the relevant accident prevention rules.
- Use suitable assembly and transport equipment and take precautions to prevent jamming and crushing.

#### Incorrect lifting of loads

Falling loads may cause serious injuries and even death.

- Stand clear of suspended loads and do not step into their swiveling range.
- Never move loads without supervision.
- Do not leave suspended loads unattended.

### **2.13.2 Protection during commissioning and operation**

#### **Falling or violently ejected components**

Falling and violently ejected components can cause serious injuries and even death.

- Take appropriate protective measures to secure the danger zone.
- Never step into the danger zone during operation.

### **2.13.3 Protection against dangerous movements**

#### **Unexpected movements**

Residual energy in the system may cause serious injuries while working with the product.

- Switch off the energy supply, ensure that no residual energy remains and secure against inadvertent reactivation.
- Never rely solely on the response of the monitoring function to avert danger. Until the installed monitors become effective, it must be assumed that the drive movement is faulty, with its action being dependent on the control unit and the current operating condition of the drive. Perform maintenance work, modifications, and attachments outside the danger zone defined by the movement range.
- To avoid accidents and/or material damage, human access to the movement range of the machine must be restricted. Limit/prevent accidental access for people in this area due through technical safety measures. The protective cover and protective fence must be rigid enough to withstand the maximum possible movement energy. EMERGENCY STOP switches must be easily and quickly accessible. Before starting up the machine or automated system, check that the EMERGENCY STOP system is working. Prevent operation of the machine if this protective equipment does not function correctly.

#### 2.13.4 Protection against electric shock

##### Possible electrostatic energy

Components or assembly groups may become electrostatically charged. When the electrostatic charge is touched, the discharge may trigger a shock reaction leading to injuries.

- The operator must ensure that all components and assembly groups are included in the local potential equalisation in accordance with the applicable regulations.
- While paying attention to the actual conditions of the working environment, the potential equalisation must be implemented by a specialist electrician according to the applicable regulations.
- The effectiveness of the potential equalisation must be verified by executing regular safety measurements.

## 2.14 Notes on particular risks



### **⚠ DANGER**

#### **Risk of fatal injury from suspended loads!**

Falling loads can cause serious injuries and even death.

- Stand clear of suspended loads and do not step within their swiveling range.
- Never move loads without supervision.
- Do not leave suspended loads unattended.
- Wear suitable protective equipment.



### **⚠ WARNING**

#### **Risk of injury from objects falling and being ejected!**

Falling and ejected objects during operation can lead to serious injury or death.

- Take appropriate protective measures to secure the danger zone.



### **⚠ WARNING**

#### **Risk of injury due to unexpected movements!**

If the power supply is switched on or residual energy remains in the system, components can move unexpectedly and cause serious injuries.

- Before starting any work on the product: Switch off the power supply and secure against restarting.
- Make sure, that no residual energy remains in the system.



**⚠ WARNING****Risk of injury from crushing and impacts!**

Serious injury could occur during the base jaw procedure and when breaking or loosening the gripper fingers.

- Wear suitable protective equipment.
- Do not reach into the open mechanism or the movement area of the product.

**⚠ WARNING****Risk of injury from sharp edges and corners!**

Sharp edges and corners can cause cuts.

- Use suitable protective equipment.

**⚠ WARNING****Risk of injury due to spring forces!**

Parts are under spring tension on products which clamp using spring force or which have gripping force maintenance. While disassembling components can move unexpectedly and cause serious injuries.

- Disassemble the product cautiously.
- Make sure that no residual energy remains in the system.

**⚠ WARNING****Risk of injury from objects falling during energy supply failure**

Products with a mechanical gripping force maintenance can, during energy supply failure, still move independently in the direction specified by the mechanical gripping force maintenance.

- Secure the end positions of the product with SCHUNK SDV-P pressure maintenance valves.

### 3 Technical data

Designation	MPG
Pressure medium	Compressed air, compressed air quality according to ISO 8573-1:7 4 4
Nominal working pressure [bar]	6
Min. pressure [bar] without gripping force maintenance	2
with gripping force maintenance	4
Max. pressure [bar] without gripping force maintenance	8
with gripping force maintenance	6.5
Noise emission [dB(A)]	≤ 70

More technical data is included in the catalog data sheet. Whichever is the latest version.

#### Ambient conditions and operating conditions

Designation	MPG
Ambient temperature [°C] min.	+5
max.	+90
Protection class IP *	30
Noise emission [dB(A)]	≤ 70

\* For use in dirty ambient conditions (e.g. sprayed water, vapors, abrasion or processing dust) SCHUNK offers corresponding product options as standard. SCHUNK also offers customized solutions for special applications in dirty ambient conditions.

## 4 Design and description

### 4.1 Configuration

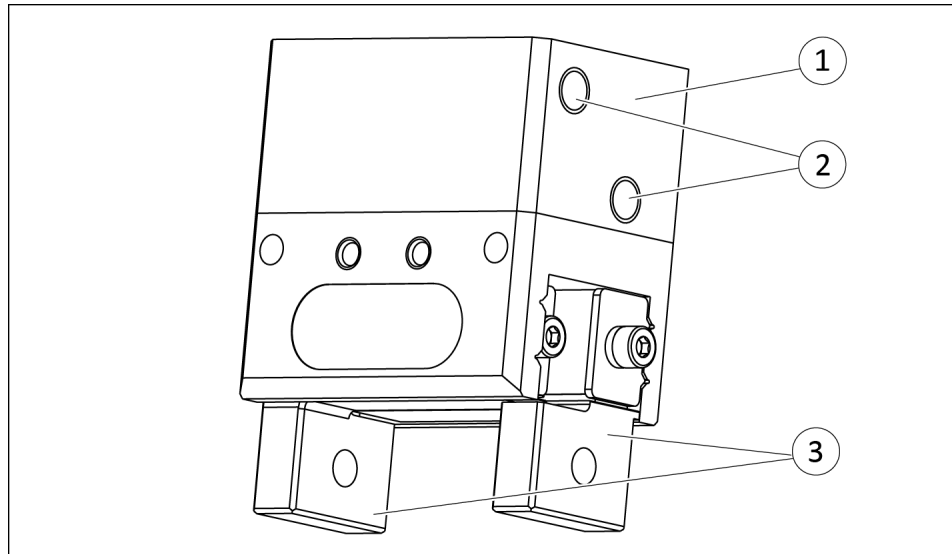

*2-Finger Parallel-Gripper*

1	Housing
2	Main air connections
3	Base jaws

### 4.2 Description

2-finger parallel gripper with smooth roller guides on the base jaws

## 5 Assembly

### 5.1 Assembly and connection



#### **⚠ WARNING**

##### **Risk of injury due to unexpected movements!**

If the power supply is switched on or residual energy remains in the system, components can move unexpectedly and cause serious injuries.

- Before starting any work on the product: Switch off the power supply and secure against restarting.
- Make sure, that no residual energy remains in the system.

#### **CAUTION**

##### **Damage to the gripper is possible!**

If the maximum permissible finger weight or the permissible mass moment of inertia of the fingers is exceeded, the gripper can be damaged.

- A jaw movement always has to be without jerks and bounce.
- You must therefore implement sufficient reduction and/or damping.
- Observe the diagrams and information in the catalog data sheet.

#### **NOTE**

- Observe the requirements for the compressed air supply, [Technical data](#) [▶ 18].
- In case of compressed air loss (cutting off the energy line), the components lose their dynamic effects and do not remain in a secure position. However, the use of a SDV-P pressure maintenance valve is recommended in this case in order to maintain the dynamic effect for some time. Product variants are also offered with mechanical gripping force via springs, which also ensure a minimum clamping force in the event of a pressure drop.

- Check the evenness of the mounting surface, [Mechanical connection](#) [▶ 22].
- Only open the required air connections (main connection or direct connection), [Pneumatic connection](#) [▶ 24].
- Connect the product via the hose-free direct connection.
  - ✓ Use O-rings from the accessory pack.
  - ✓ Seal main air connections which are not required with locking screws.
- OR: Connect compressed air lines to the main air connections "A" and "B".
  - ✓ Screw in air connections (plug connections).  
OR: Screw on throttle valve in order to be able to perform sufficient throttling and/or damping.
- Screw the product to the machine/system, [Mechanical connection](#) [▶ 22].
  - ✓ If necessary, use appropriate connection elements (adapter plates).
  - ✓ Observe the maximal tightening torque, admissible screw-in depth and, if necessary, strength class.
- Secure the gripper fingers to the base jaws, [Mechanical connection](#) [▶ 22].
- Connect the sensor, see assembly and operating manual of the sensor.
- Mount the sensor, [Mounting the sensor](#) [▶ 26].

## 5.2 Connections

### 5.2.1 Mechanical connection

#### Evenness of the mounting surface

The values apply to the whole mounting surface to which the product is mounted.

*Requirements for evenness of the mounting surface (Dimensions in mm)*

Edge length	Permissible unevenness
< 100	< 0.02
> 100	< 0.05

#### Connections at the product

The product can be mounted from three sides.

When selecting the mounting screws, observe the values prescribed by SCHUNK, see table below.

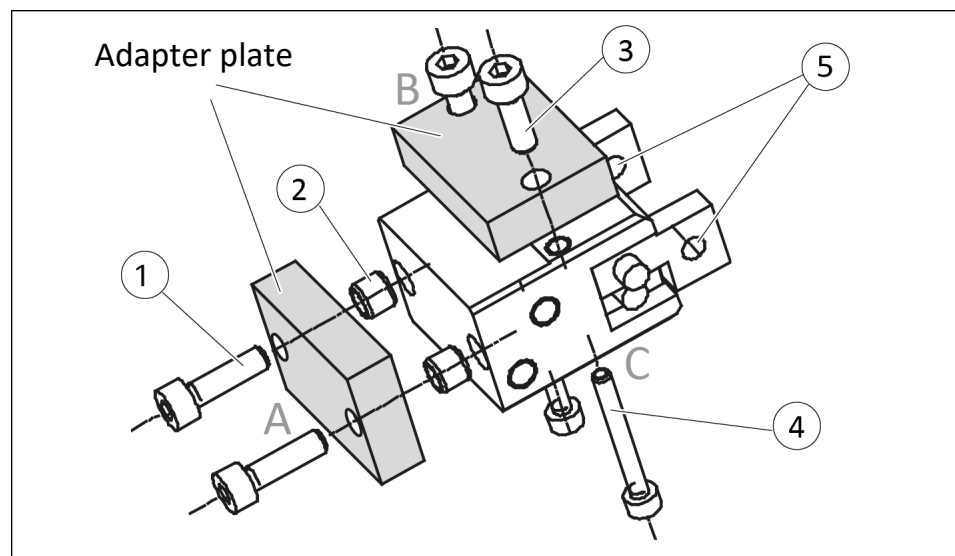

*Assembly options*

Item	Mounting	MPG							
		16	20	25	32	40	50	64	80
Side A									
1	Screw	M2	M2.5	M3	M4	M4	M5	M5	M6
	Max. depth of engagement [mm]	4	6	7.4	8	9	11	11	12.9
2	Centering sleeve [mm]	∅3	∅4	∅5	∅6	∅6	∅8	∅8	∅10
Side B									
3	Screw	M2	M2.5	M3	M4	M4	M5	M5	M6
	Max. depth of engagement [mm]	4	3.5	6	6	8	10	10	13.9
2	Centering sleeve [mm]	∅3	-	-	-	-	-	-	-
Side C									
4	Screw	-	M2x20	M2.5x25	M3x25	M3x30	M4x35	M4x40	M5x55
	Screw according to standard	DIN EN ISO 4762 Max. strength class 8.8							
2	Centering sleeve [mm]	∅3	-	-	-	-	-	-	-
Connections at the base jaws									
5	Bore for mounting screws [mm]	∅2.5	∅3	∅3	∅4	∅4	∅5	∅6	∅8

### 5.2.2 Pneumatic connection

**NOTE**

The central compressed air supply line must be equipped with a maintenance unit that is positioned as near as possible to the consumer.

**NOTE**

Only use carbide bits to remove the bottom grub screws.

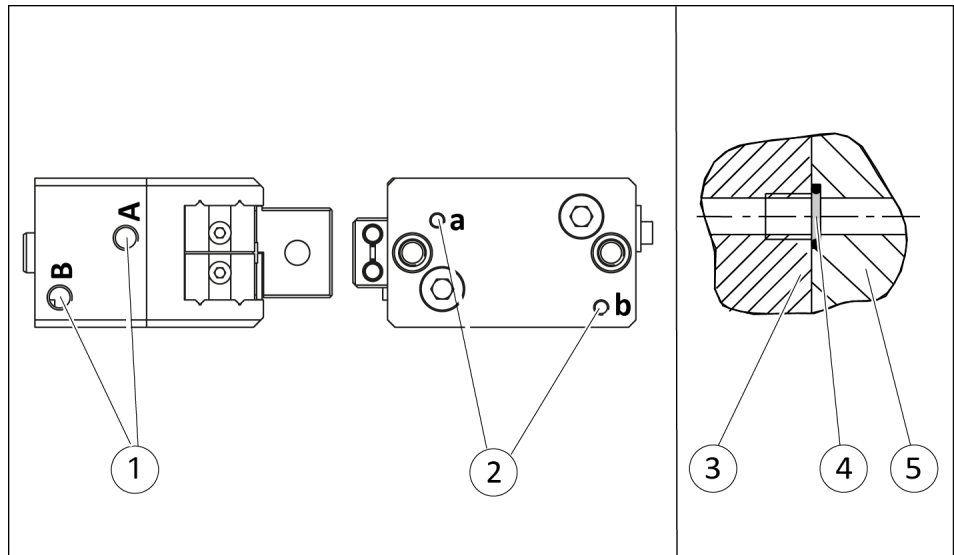

*Compressed air connections*

1	Main connections (Hose connection) (A = open, B = close)		
2	Hose-free direct connection at the base (a = open, b = close)		
Hose-free direct connection			
3	Product	5	Attachment
4	O-ring		



Item	Mounting	MPG							
		16	20	25	32	40	50	64	80
1	Thread in the main air connections	*	M3	M3	M5	M5	M5	M4	M5
	Max. depth of engagement from locating surface [mm]	-	3	3.5	4.5	5	5	5	5
2	Hose-free direct connection dimensions	-	-	M3	M3	M3	M3	M3	M4

\* For this size, the hose clips are pre-assembled at the factory and the compressed air hoses prescribed by SCHUNK must be used, see catalog data sheet. Procedure for leaking compressed air connection, see section "Troubleshooting".

### 5.3 Mounting the sensor

#### NOTE

Observe the assembly and operating manual of the sensor for mounting and connecting.

The product is prepared for the use of sensors.

- For the exact type designations of suitable sensors, please see catalog datasheet and [Overview of sensors](#) [► 26].
- For technical data for the suitable sensors, see assembly and operating manual and catalog datasheet.
  - The assembly and operating manual and catalog datasheet are included in the scope of delivery for the sensors and are available at [schunk.com](http://schunk.com).
- Information on handling sensors is available at [schunk.com](http://schunk.com) or from SCHUNK contact persons.

#### 5.3.1 Overview of sensors

Designation	MPG							
	16	20	25	32	40	50	64	80
Inductive proximity switch IN 30	X	–	–	–	–	–	–	–
Inductive proximity switch IN 5	–	–	X	X	X	X	X	X
Inductive proximity switch IN 40	–	X	X	X	X	X	X	X
Flexible position sensor FPS	–	special housing version			X	X	X	X
Optical distance sensor OAS	–	–	X	X	X	X	X	–

#### 5.3.2 Mounting the inductive proximity switch IN 5

##### Mounting kit

To use the inductive sensor, the gripper has to be retrofitted with a special mounting kit. This mounting kit is available from SCHUNK for the models below.

Note: The assembly of the mounting set is different for products up to construction year 12/2015 and from construction year 01/2016.

Up to construction year 12/2015:

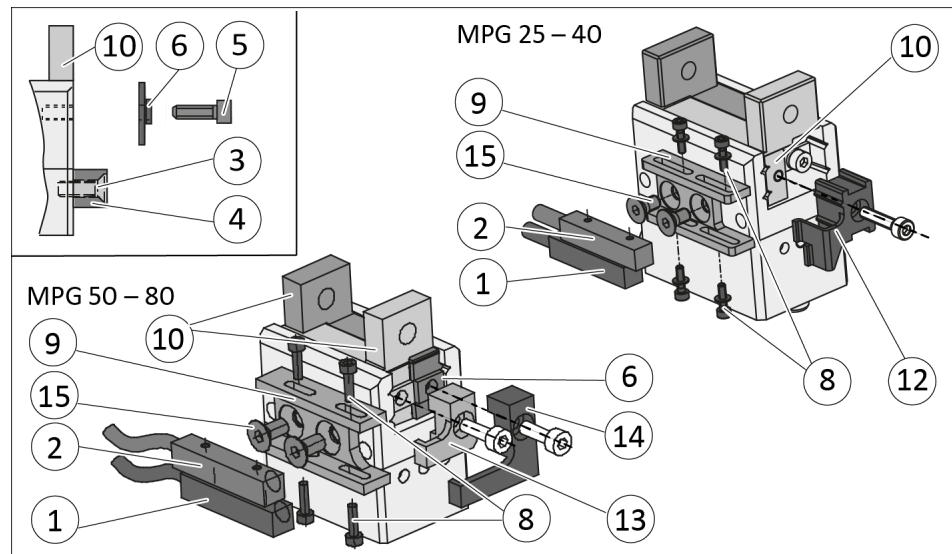

- Loosen screw (3) and remove bracket (4).
- Secure bracket (9) with screws (15).
- **MPG 25 – 40:**
  - ✓ Remove screws (5) and cover (6) on the base jaw (10) next to the bracket (9).
  - ✓ Secure cam switch (12) to the base jaw (10).
- **MPG 50 – 80:**
  - ✓ Remove screws (5) and cover (6) on both base jaws.
  - ✓ Secure cam switches (13, 14) with the covers (6) to the base jaws.
- Insert sensors (1, 2) in the bracket (9). Ensure that the buttons are facing in the direction of the cam switch.
- Secure sensors (1, 2) with screws (8). Tighten screws only slightly.
- Adjust sensors, see following section.

**From construction year 01/2016:**

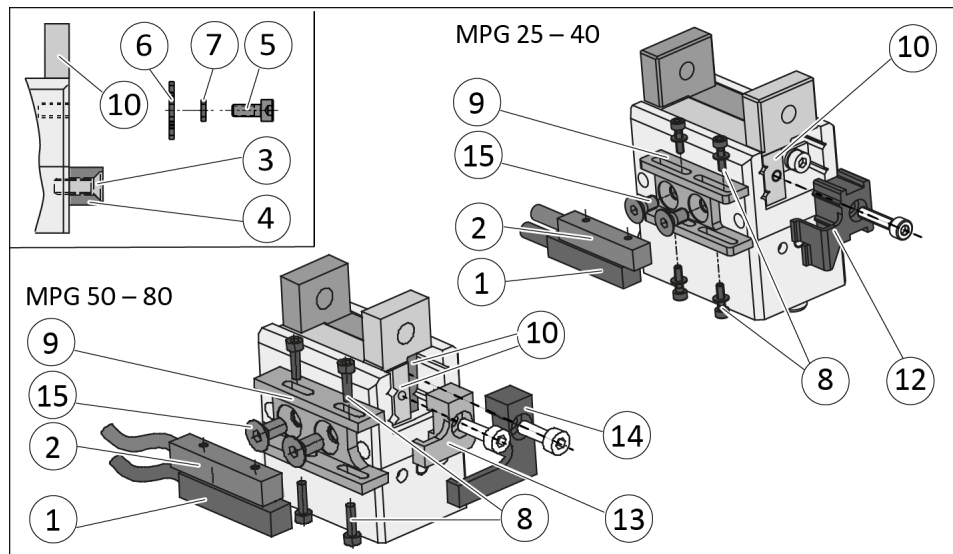

- Loosen screw (3) and remove bracket (4).
- Secure bracket (9) with screws (15).
- **MPG 25 – 40:**
  - ✓ Remove screws (5), spacer shim (7) and retaining plate (6) on the base jaw (10) next to the bracket (9).
  - ✓ Secure cam switch (12) to the base jaw (10).
- **MPG 50 – 80:**
  - ✓ Remove screws (5), spacer shim (7) and retaining plate (6) on both base jaws (10).
  - ✓ Secure cam switches (13, 14) to the base jaws (10).
- Insert sensors (1, 2) in the bracket (9). Ensure that the buttons are facing in the direction of the cam switch.
- Secure sensors (1, 2) with screws (8). Tighten screws only slightly.
- Adjust sensors, see following section.

**Adjusting the sensors** The sensors can be set to the following queries:

**Position "opened"**

- Move the gripper into the required position.
- Push the sensor to the switching lug.
- Slowly pull the sensor back until it switches. Then retract the sensor further by 0.2 mm.
- Tighten the screws (8).
- Query the position "opened" and test the function.

**Position "closed"**

- Move the gripper into the required position.
- Move the sensor into the direction of the switching lug until it switches. Then push the sensor further into the direction of the switching lug by 0.2 mm.
- Tighten the screws (8).
- Query the position "closed" and test the function.

**Position "Part gripped (O.D. gripping)" or "Part gripped (I.D. gripping)"**

- Part gripped.
- Move the sensor into the direction of the switching lug until it switches. Then push the sensor further into the direction of the switching lug by 0.2 mm.
- Tighten the screws (8).
- Query the position "Part gripped (O.D. gripping)" or "Part gripped (I.D. gripping)" and test the function.

### 5.3.3 Mounting the inductive proximity switch IN 3, IN 40

#### Mounting kit

To use the inductive sensor, the gripper has to be retrofitted with a special mounting kit. This mounting kit is available from SCHUNK for the models below.

#### CAUTION

##### Risk of damage to the sensor during assembly!

- Observe the maximal tightening torque.

#### NOTE

The sensors are dampened by the screw heads.

For sizes MPG 25 – 80, a spacer sleeve is also used to monitor "Part gripped" position.

For sizes MPG 16 – 20, it is not possible to monitor "Part gripped" position.

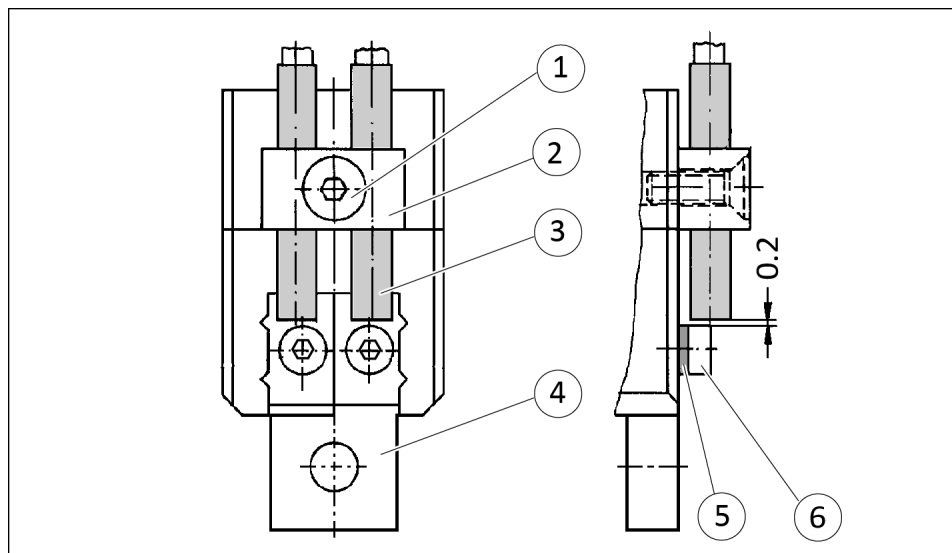

- For "opened" or "closed" monitoring: secure screw (6) in the base jaw (4).  
For tightening torque, see following table.  
Mount spacer sleeve (5) on the housing on the side of the main air connections to keep it in the immediate vicinity of the product.
- For "Part gripped" monitoring: secure spacer sleeve (5) and screw (6) to the base jaw (4).  
For tightening torque, see following table.
- Secure holder (2). Tighten screw (1) only slightly.

Designation	MPG							
	16	20	25	32	40	50	64	80
Maximum tightening torque for the screw item 6 [Ncm]	16	34	34	68	68	68	120	310

## Adjusting the sensor

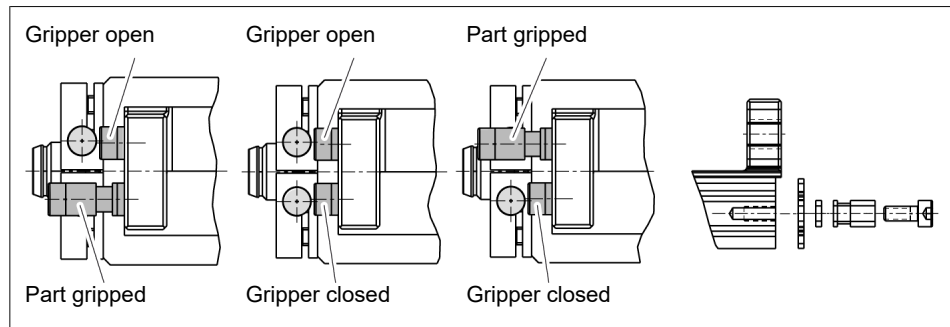

- Place the product in the desired position.
- Slide sensor (3) into the holder (2) and set a distance of 0.2 mm to the screw head.
- Tighten screw (1).  
Tightening torque:  
MPG 16: 10 Ncm  
MPG 20 – 80: 12.5 Ncm
- Monitor the "opened", "closed" or "part gripped" positions and test the function.

### 5.3.4 Mounting flexible position sensor FPS

The flexible position sensor FPS consists of a torque sensor system controller and the sensor FPS-S 13.

To operate the sensor for the sizes MPG 20 / 25 / 32, the grippers are available with special housing variants, that are prepared for the attachment of the position sensor FPS-S 13. For these grippers, the position sensor FPS-S 13 is directly mounted on the gripper.

To operate the sensor for the sizes MPG 40 / 50 / 64 / 80, a mounting kit must be mounted on the gripper. This mounting kit is available from SCHUNK. For types that can be ordered, see the catalog data sheet.

## CAUTION

### Risk of damage to the sensor during assembly!

- Observe the maximal tightening torque.

**Size MPG 20 / 25 / 32**

For these sizes, the sensor is mounted directly onto the housing.

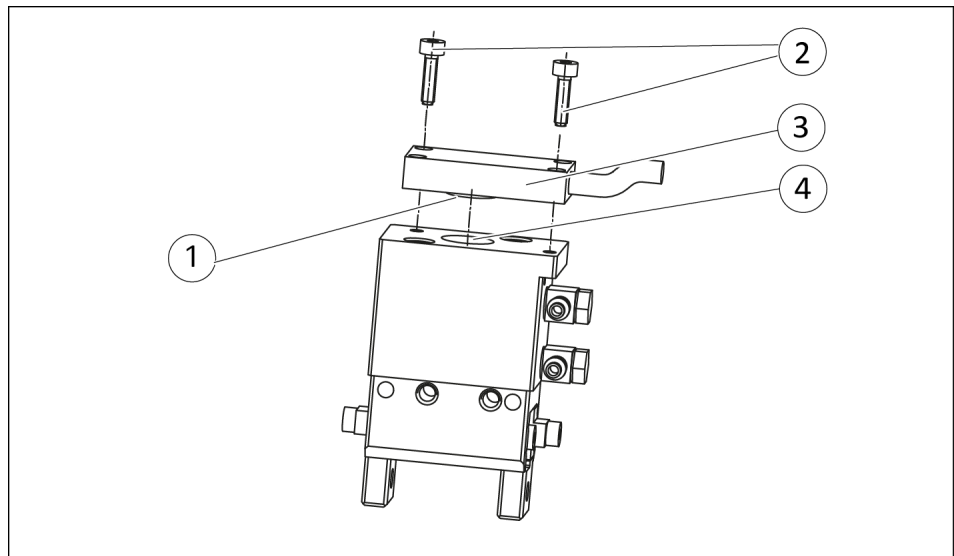

- Position sensor (3) with the circular elevation (1) in the recess in the housing (4).
- Secure sensor with screws (2).  
Tightening torque: 10 Ncm
- Connect the torque sensor system controller and adjust the sensor, see sensor assembly and operating manual.

**Size MPG 40 / 50 / 64 / 80**

For these sizes, a bracket must be mounted. This bracket is available from SCHUNK.

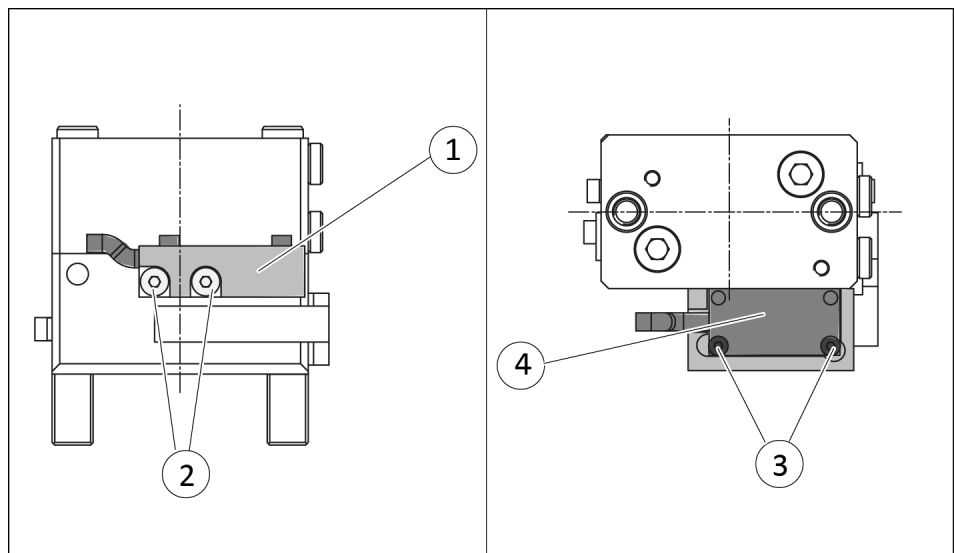

- Secure bracket (1) with screws (2).
- Position sensor (4) with the circular elevation in the bore in the bracket (1).
- Secure sensor (4) with screws (3).  
Tightening torque: 10 Ncm



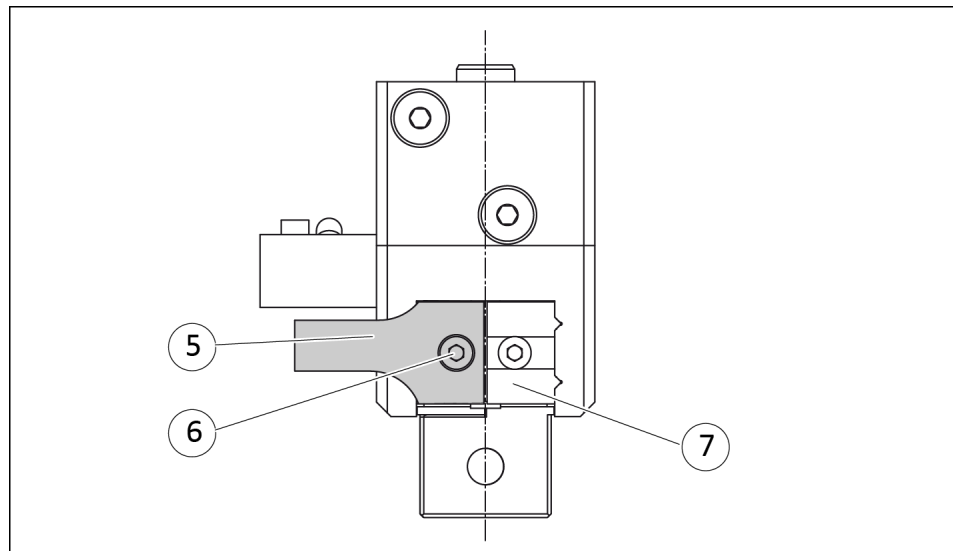

- **Up to construction year 12/2015:** Secure control cam (5) with screw (6) on the cover (7). Ensure that the magnets are facing towards the sensor surface.
- **From construction year 01/2016:** Secure control cam (5) with screw (6) on the base jaw. Ensure that the magnets are facing towards the sensor surface.
- Connect the torque sensor system controller and adjust the sensor, see sensor assembly and operating manual.

### 5.3.5 Mounting the object-distance sensor OAS

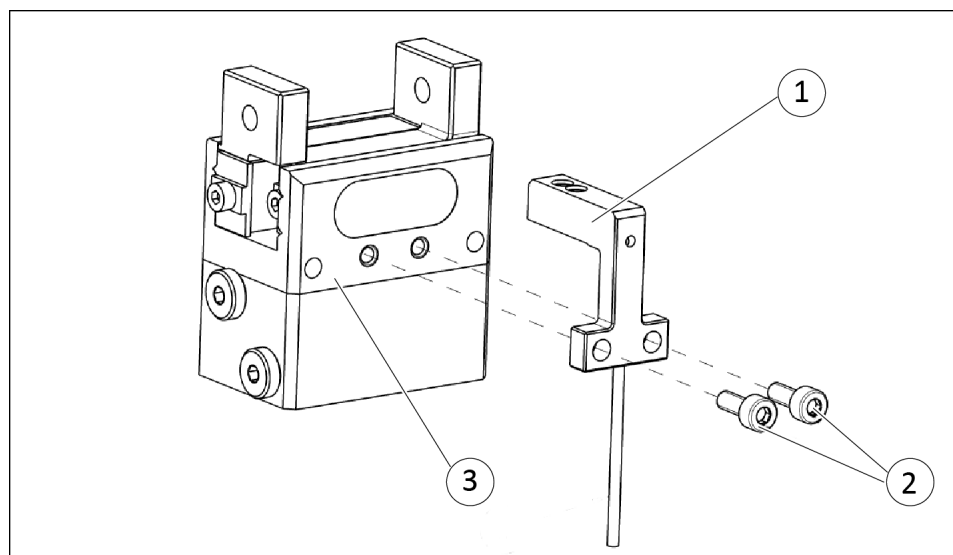

- Fix sensor (1) with screws (2) at the housing (3).  
Notice: The screws (2) are not included in the scope of delivery.
- Connect control unit output and adjust sensor, see sensor mounting and operating manual.

## 6 Troubleshooting

### 6.1 Product is not moving

Possible cause	Corrective action
Base jaws jam in housing, e.g. mounting surface is not sufficiently even.	Check the evenness of the mounting surface. <a href="#">Mechanical connection</a> [▶ 22]
	Loosen the mounting screws of the product and actuate the product again.
Pressure drops below minimum.	Check air supply. <a href="#">Pneumatic connection</a> [▶ 24]
Compressed air lines switched.	Check compressed air lines. <a href="#">Pneumatic connection</a> [▶ 24]
Proximity switch defective or set incorrect.	Readjust or change sensor.
Unused air connections open.	Close unused air connections.
Flow control valve closed.	Open the flow control valve.
Component part defective.	Replace component or send it to SCHUNK for repair.

### 6.2 Product is not executing the complete stroke

Possible cause	Corrective action
Dirt deposits between cover and piston.	Clean and if necessary re-lubricate.
Dirt deposits between basic jaws and guidance.	Disassemble and clean the product.
Pressure drops below minimum.	Check air supply. <a href="#">Pneumatic connection</a> [▶ 24]
Mounting surface is not sufficiently flat.	Check the evenness of the mounting surface. <a href="#">Mechanical connection</a> [▶ 22]
Component part defective.	Replace component or send it to SCHUNK for repair.

### 6.3 Product is opening or closing abruptly

Possible cause	Corrective action
Too little grease in the mechanical guiding areas.	Clean and lubricate product.
Compressed air lines blocked.	Check compressed air lines of damage.
Mounting surface is not sufficiently flat.	Check the evenness of the mounting surface.

### 6.4 Gripping force is dropping

Possible cause	Corrective action
Compressed air can escape.	Check seals, if necessary, disassemble the product and replace seals.
Too much grease in the mechanical movement space.	Clean and lubricate product.
Pressure drops below minimum.	Check air supply. <a href="#">Pneumatic connection</a> [▶ 24]
Component part defective.	Replace component or send it to SCHUNK for repair.

### 6.5 Product does not achieve the opening and closing times

Possible cause	Corrective action
Compressed air lines are not installed optimally.	If present: Open the flow control couplings on the product to the maximum that the movement of the jaws occurs without bouncing and hitting.
	Check compressed air lines.
	Inner diameters of compressed air lines are of sufficient size in relation to compressed air consumption.
	Keep compressed air lines between the product and directional control valve as short as possible.
	Flow rate of valve is sufficiently large relative to the compressed air consumption.
	<b>IMPORTANT! The throttle check valve must not be removed, even if the product has not reached the opening and closing times.</b>
	If, despite optimum air connections, the opening and closing times specified in the catalogue are not achieved, SCHUNK recommends the use of quick-air-vent-valves directly at the product.

### 6.6 Compressed air connection is leaking

Possible cause	Corrective action
Wrong hose.	Check hose, see catalog data sheet.
Hose gets wider if it is frequently disassembled/assembled.	Cut off hose, replace if necessary.
Hose gets wider due to external forces.	Fix hose e.g. using cable tie.

## 7 Maintenance

### 7.1 Notes

#### Original spare parts

Use only original spare parts of SCHUNK when replacing spare and wear parts.

#### Exchange of housing and base jaws

The base jaws and the guidance in the housing are matched. To exchange these parts, send the product with a repair order to SCHUNK.

#### Maintenance of version with gripping force maintenance I.D. gripping and O.D. gripping

The pistons have to be aligned using an assembly device. Therefore we recommend to have the module serviced and the seals replaced by SCHUNK.

### 7.2 Maintenance intervals

#### CAUTION

#### Material damage due to hardening lubricants!

Lubricants harden more quickly at temperatures above 60°C, leading to possible product damage.

- Reduce the lubricant intervals accordingly.

Interval (million cycles) for MPG 16 - 80	Maintenance work
10	Clean all parts thoroughly, check for damage and wear, if necessary replace seals and wearing parts. <ul style="list-style-type: none"> <li>• Notes for disassembly, <a href="#">Disassembling and assembling</a> [▶ 38]</li> <li>• Position of the wearing parts, <a href="#">Drawings</a> [▶ 42]</li> <li>• Seal kit, <a href="#">Seal kit</a> [▶ 7]</li> </ul>
10	Treat all grease areas with lubricant, <a href="#">Lubricants/Lubrication points</a> [▶ 38]
10	Oil or grease external steel parts.

### 7.3 Lubricants/Lubrication points

SCHUNK recommends the lubricants listed.

During maintenance, treat all greased areas with lubricant. Thinly apply lubricant with a lint-free cloth.

Lubricant point	Lubricant
Metallic sliding surfaces	Isoflex-Topas NCA 52
All seals	Sealgood 1
Bore hole at the piston	Sealgood 1

### 7.4 Disassembling and assembling



#### **⚠ WARNING**

##### **Risk of burns through contact with hot surfaces!**

Surfaces of components can heat up severely during operation. Skin contact with hot surfaces causes severe burns to the skin.

- For all work in the vicinity of hot surfaces, wear safety gloves.
- Before carrying out any work, make sure that all surfaces have cooled down to the ambient temperature.

### 7.4.1 Variant without gripping force maintenance

Position of the item numbers [Drawings](#) [► 42]

#### Disassembling

##### NOTE

The following steps are required for lubricating the product and replacing the sealing ring (25).

It is not possible to replace the base jaws (3) and the cover housing (1), since these parts are matched to each other.

- Remove the compressed air line.
- Unscrew the screws (18) and remove the housing (2).
- Unscrew screw (19) and pull off piston (5).  
**Only for size 20:** Piston (5) is screwed directly to the piston rod (4).  
**Only for FPS variant:** Fit set-screw (69), whilst unscrewing the piston (65), [FPS variant](#) [► 44].
- Unscrew screws (20/21) and take off bracket (8).

##### NOTE

The needle rollers are suitable only for this product and cannot be replaced with needle rollers belonging to another product of the same type and size.

- Remove needle rollers (15) and roller cages or cylindrical pins (14).
- Pull base jaw (3) and the piston rod (4) out of the cover housing (1).

#### Assembling

Assembly takes place in the opposite order to disassembly. Observe the following:

- Unless otherwise specified, secure all screws and nuts with Loctite no. 243 and tighten with the appropriate tightening torque.

[Tightening torque for screws](#) [► 42].

### 7.4.2 Variant with gripping force maintenance for "O.D. Gripping"

Position of the item numbers [Drawings](#) [▶ 42]

#### Disassembling



#### **⚠ WARNING**

##### **Risk of injury due to spring forces!**

The cover is under spring tension.

- Carefully disassemble the product.

- 
- Remove the compressed air lines.
  - **CAUTION The housing (42) is under spring tension.** Clamp the product between the housing (42) and the cover housing (1).
  - Remove screws (48) and slowly unclamp the spring (41). Remove housing (42).

#### **NOTE**

The following steps are required for lubricating the product and replacing the sealing ring (25). It is not possible to replace the base jaws (3) and the cover housing (1), since these parts are matched to each other.

- 
- Unscrew screw (19) and pull off piston (5).  
**Only for size 20:** Piston (5) is screwed directly to the piston rod (4).
  - Unscrew screws (20/21) and remove bracket (8).
  - Remove needle rollers (15) and roller cages (14).

#### **NOTE**

The needle rollers are suitable only for this product and cannot be replaced with needle rollers belonging to another product of the same type and size.

- 
- Pull base jaw (3) and piston rod (4) out of the cover housing (1).

#### Assembling

Assembly takes place in the opposite order to disassembly.

Observe the following:

- Unless otherwise specified, secure all screws and nuts with Loctite no. 243 and tighten with the appropriate tightening torque.

[Tightening torque for screws](#) [▶ 42].



### 7.4.3 Variant with maintenance of gripping force (I.D. gripping)

Position of the item numbers [Drawings](#) [▶ 42]

#### Disassembling



#### **⚠ WARNING**

##### **Risk of injury due to spring forces!**

The cover is under spring tension.

- Carefully disassemble the product.

- Remove the compressed air lines.
- Unscrew the screws (48) and remove the housing (42).

#### **NOTE**

The following steps are required for lubricating the product and replacing the sealing ring (25).

It is not possible to replace the base jaws (3) and the cover housing (1), since these parts are matched to each other.

- **CAUTION The piston (45) is under spring tension.** Secure piston (45) against springing out uncontrollably and unscrew the screw (19).
- Release the tension on the spring (41) and remove the piston (45).  
**Only for size 20:** Piston (45) is screwed directly to the piston rod (4).
- Unscrew screws (20/21) and take off bracket (8).
- Remove needle rollers (15) and roller cages (14).

#### **NOTE**

The needle rollers are suitable only for this product and cannot be replaced with needle rollers belonging to another product of the same type and size.

- Pull base jaw (3) and the piston rod (4) out of the cover housing (1).

#### Assembling

Assembly takes place in the opposite order to disassembly. Observe the following:

- Unless otherwise specified, secure all screws and nuts with Loctite no. 243 and tighten with the appropriate tightening torque.

[Tightening torque for screws](#) [▶ 42].

## 7.5 Tightening torque for screws

Position of the item numbers [Drawings](#) [▶ 42]

*Tightening torque [Nm]*

Item	MPG							
	16	20	25	32	40	50	64	80
5	-	2.2	-	-	-	-	-	-
18	0.88	0.6	0.6	1.1	2.6	5.1	5.1	8.0
19	0.65	-	0.8	0.8	2.2	2.2	5.9	10.0
20	0.16	0.34	0.34	0.68	0.68	0.68	1.2	3.1
21	0.16	0.34	0.34	0.68	0.68	0.68	1.2	3.1
45	-	2.2	-	-	-	-	-	-
48	0.88	0.6	0.6	1.1	2.6	5.1	5.1	8.0
49	0.65	-	2.7	2.7	4.9	4.9	10	10.0
65	-	2.2	1.3	1.3	-	-	-	-
68	-	0.6	0.6	1.1	-	-	-	-

## 7.6 Drawings

The following figures are example images.

They serve for illustration and assignment of the spare parts.

Variations are possible depending on size and variant.

7.6.1 Size 16-80

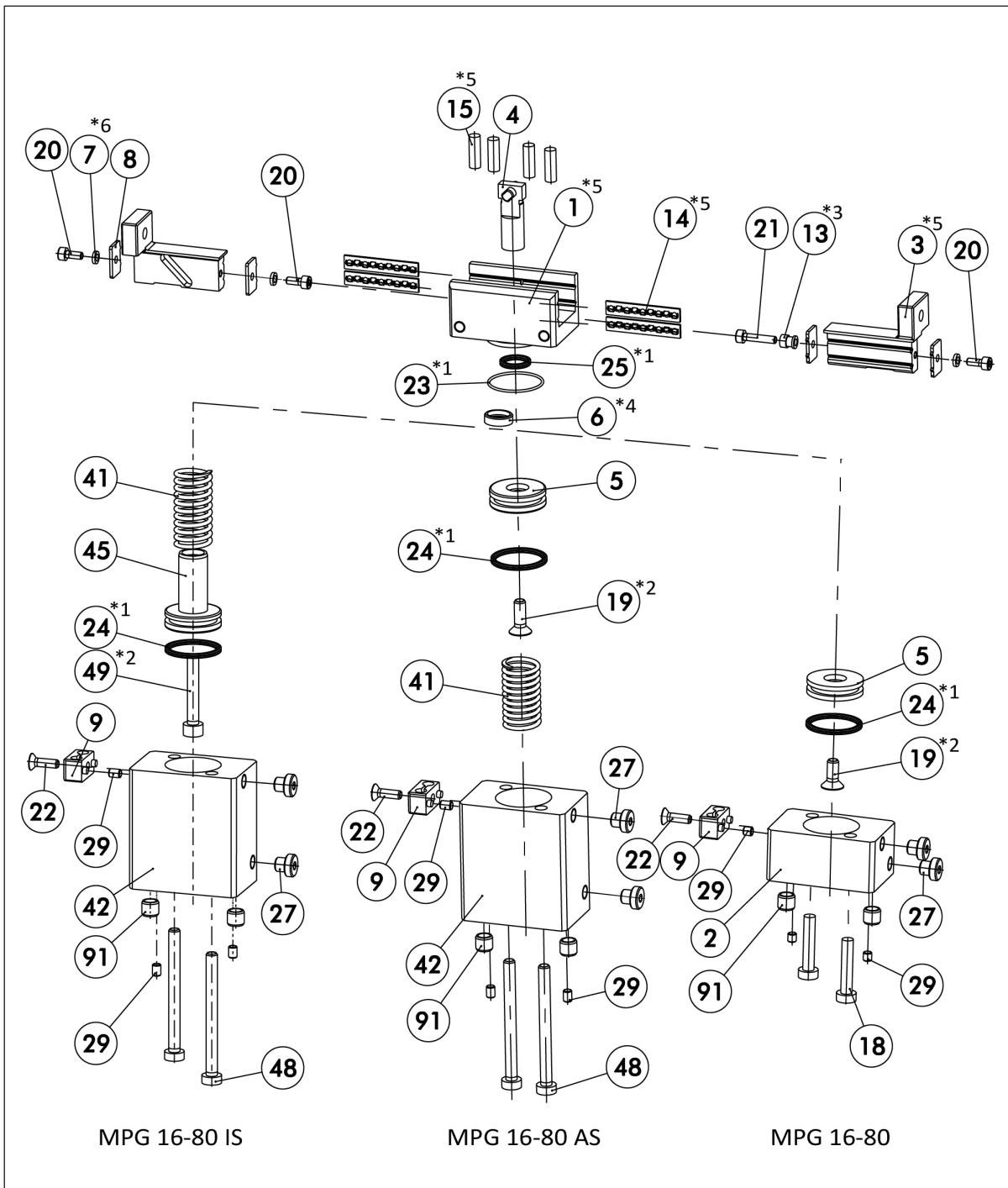

Drawing size 16 – 80, variant with maintenance of gripping force "I.D. gripping" (IS), "O.D. gripping" (AS) and without maintenance of gripping force

- \*1 Wearing part, replace during maintenance.  
Included in the seal kit. Seal kit can only be ordered completely.
- \*2 Not applicable for size 20
- \*3 Not applicable for sizes 16 / 20
- \*4 Not applicable for sizes 40-80
- \*5 Positions are adapted to each other and can not be replaced by the customer.
- \*6 Not applicable for sizes 32 / 40 / 50

### 7.6.2 FPS variant

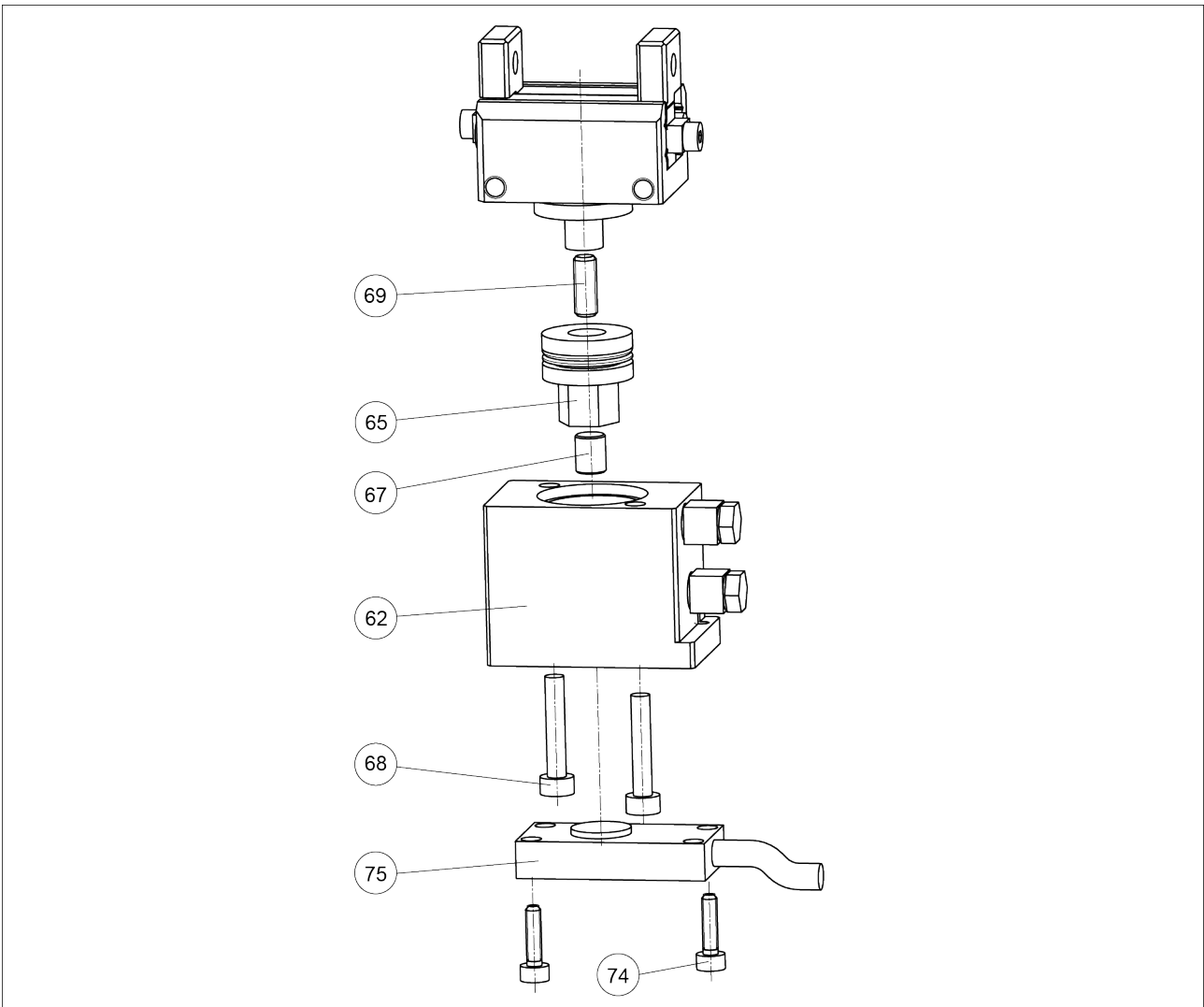

*Drawing, FPS variant*



## 9 Annex to Declaration of Incorporation

according 2006/42/EG, Annex II, No. 1 B

1. Description of the essential health and safety requirements pursuant to 2006/42/EC, Annex I that are applicable and that have been fulfilled with:

Product designation	2-Finger Parallel-Gripper
Type designation	MPG
ID number	0340006 ... 0340071

To be provided by the System Integrator for the overall machine	↓
Fulfilled for the scope of the partly completed machine	↓
Not relevant	↓

1.1	Essential Requirements			
1.1.1	Definitions		X	
1.1.2	Principles of safety integration		X	
1.1.3	Materials and products		X	
1.1.4	Lighting		X	
1.1.5	Design of machinery to facilitate its handling		X	
1.1.6	Ergonomics		X	
1.1.7	Operating positions			X
1.1.8	Seating			X

1.2	Control Systems			
1.2.1	Safety and reliability of control systems		X	
1.2.2	Control devices		X	
1.2.3	Starting		X	
1.2.4	Stopping		X	
1.2.4.1	Normal stop		X	
1.2.4.2	Operational stop		X	
1.2.4.3	Emergency stop		X	
1.2.4.4	Assembly of machinery		X	
1.2.5	Selection of control or operating modes		X	
1.2.6	Failure of the power supply			X

1.3	Protection against mechanical hazards			
1.3.1	Risk of loss of stability			X
1.3.2	Risk of break-up during operation			X
1.3.3	Risks due to falling or ejected objects			X
1.3.4	Risks due to surfaces, edges or angles		X	
1.3.5	Risks related to combined machinery			X

<b>1.3</b>	<b>Protection against mechanical hazards</b>			
1.3.6	Risks related to variations in operating conditions			X
1.3.7	Risks related to moving parts		X	
1.3.8	Choice of protection against risks arising from moving parts			X
1.3.8.1	Moving transmission parts		X	
1.3.8.2	Moving parts involved in the process			X
1.3.9	Risks of uncontrolled movements			X
<b>1.4</b>	<b>Required characteristics of guards and protective devices</b>			
1.4.1	General requirements			X
1.4.2	Special requirements for guards			X
1.4.2.1	Fixed guards			X
1.4.2.2	Interlocking movable guards			X
1.4.2.3	Adjustable guards restricting access			X
1.4.3	Special requirements for protective devices			X
<b>1.5</b>	<b>Risks due to other hazards</b>			
1.5.1	Electricity supply		X	
1.5.2	Static electricity		X	
1.5.3	Energy supply other than electricity		X	
1.5.4	Errors of fitting		X	
1.5.5	Extreme temperatures			X
1.5.6	Fire			X
1.5.7	Explosion			X
1.5.8	Noise			X
1.5.9	Vibrations			X
1.5.10	Radiation	X		
1.5.11	External radiation	X		
1.5.12	Laser radiation	X		
1.5.13	Emissions of hazardous materials and substances			X
1.5.14	Risk of being trapped in a machine	X		
1.5.15	Risk of slipping, tripping or falling	X		
1.5.16	Lightning			X
<b>1.6</b>	<b>Maintenance</b>			
1.6.1	Machinery maintenance		X	
1.6.2	Access to operating positions and servicing points		X	
1.6.3	Isolation of energy sources		X	
1.6.4	Operator intervention		X	
1.6.5	Cleaning of internal parts		X	

<b>1.7</b>	<b>Information</b>			
1.7.1	Information and warnings on the machinery		X	
1.7.1.1	Information and information devices		X	
1.7.1.2	Warning devices		X	
1.7.2	Warning of residual risks		X	
1.7.3	Marking of machinery	X		
1.7.4	Instructions	X		
1.7.4.1	General principles for the drafting of instructions	X		
1.7.4.2	Contents of the instructions	X		
1.7.4.3	Sales literature	X		
	<b>The classification from Annex 1 is to be supplemented from here forward.</b>			
2	Supplementary essential health and safety requirements for certain categories of machinery			X
2.1	Foodstuffs machinery and machinery for cosmetics or pharmaceutical products			X
2.2	Portable hand-held and/or guided machinery			X
2.2.1	Portable fixing and other impact machinery			X
2.3	Machinery for working wood and material with similar physical characteristics			X
3	Supplementary essential health and safety requirements to offset hazards due to the mobility of machinery		X	
4	Supplementary essential health and safety requirements to offset hazards due to lifting operations		X	
5	Supplementary essential health and safety requirements for machinery intended for underground work			X
6	Supplementary essential health and safety requirements for machinery presenting particular hazards due to the lifting of persons		X	