

Assembly- and Operating Manual

PGN-plus-P

2-Finger Parallel Gripper

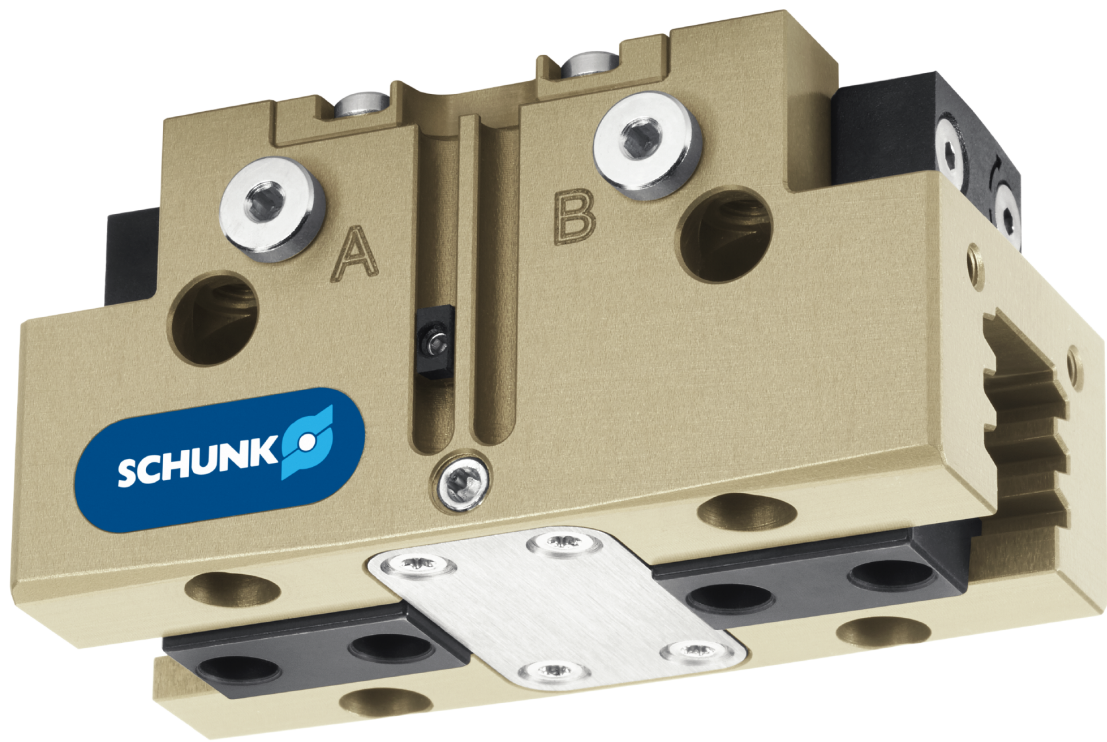

Superior Clamping and Gripping



Imprint

Copyright:

This manual is protected by copyright. The author is SCHUNK GmbH & Co. KG. All rights reserved.

Technical changes:

We reserve the right to make alterations for the purpose of technical improvement.

Document number: 389753

Version: 14.00 | 11/01/2021 | en

Dear Customer,

thank you for trusting our products and our family-owned company, the leading technology supplier of robots and production machines.

Our team is always available to answer any questions on this product and other solutions. Ask us questions and challenge us. We will find a solution!

Best regards,

Your SCHUNK team

Customer Management

Tel. +49-7133-103-2503

Fax +49-7133-103-2189

cmg@de.schunk.com



Please read the operating manual in full and keep it close to the product.

Table of Contents

1	General	5
1.1	About this manual	5
1.1.1	Presentation of Warning Labels	5
1.1.2	Applicable documents	6
1.1.3	Sizes	6
1.1.4	Variants.....	6
1.2	Warranty	7
1.3	Scope of delivery	7
1.4	Accessories	8
2	Basic safety notes	9
2.1	Intended use.....	9
2.2	Not intended use.....	9
2.3	Constructional changes	9
2.4	Spare parts	9
2.5	Gripper fingers	10
2.6	Ambient conditions and operating conditions	10
2.7	Personnel qualification	10
2.8	Personal protective equipment.....	11
2.9	Notes on safe operation	12
2.10	Transport	12
2.11	Malfunctions.....	12
2.12	Disposal	12
2.13	Fundamental dangers.....	13
2.13.1	Protection during handling and assembly	13
2.13.2	Protection during commissioning and operation	13
2.13.3	Protection against dangerous movements.....	14
2.13.4	Protection against electric shock.....	14
2.14	Notes on particular risks.....	15
3	Technical data	16
4	Design and description	17
4.1	Design	17
4.2	Description	17

5	Assembly	18
5.1	Installing and connecting.....	18
5.2	Connections.....	19
5.2.1	Mechanical connection.....	19
5.2.2	Pneumatic connection.....	22
5.3	Attaching additional structure.....	24
5.4	Mounting the sensor	26
5.4.1	Overview of sensors	26
5.4.2	Setting dimensions for magnetic switches	27
5.4.3	Switch-off hysteresis for magnetic switches	28
5.4.4	Setting dimensions for position sensors.....	29
5.4.5	Mounting inductive proximity switch IN	30
5.4.6	Mounting MMS 22 magnetic switch.....	32
5.4.7	Mounting programmable MMS 22-PI2 magnetic switch.....	33
5.4.8	Mounting programmable MMS 22-P 22 magnetic switch.....	34
5.4.9	Mounting MMS 22-PI1 programmable magnetic switch.....	35
5.4.10	Mounting the magnetic switch MMS 22-IOL.....	37
5.4.11	Mounting analog MMS 22-A magnetic switch	38
5.4.12	Mounting analog position sensor APS-Z80.....	40
5.4.13	Mount the flexible position sensor FPS.....	42
5.4.14	Mounting analog position sensor APS-M1	44
6	Troubleshooting	45
6.1	Product does not move	45
6.2	Product is not executing the complete stroke	45
6.3	Product opens or closes abruptly	46
6.4	Product does not achieve the opening and closing times	46
6.5	Gripping force is dropping.....	47
7	Maintenance	48
7.1	Notes	48
7.2	Maintenance intervals.....	48
7.3	Lubricants/Lubrication points (basic lubrication)	49
7.4	Lubricate product	49
7.5	Replace seals	50
7.5.1	Replace seal (variant without gripping force maintenance).....	50
7.5.2	Replace seal (variant with gripping force maintenance "O.D. gripping")..	51
7.5.3	Replace seal (variant with gripping force maintenance "I.D. gripping") ...	53
7.5.4	Remove dust cover	54
7.6	Installation position of the magnets in the piston.....	55
7.7	Tightening torques	56
7.8	Assembly drawing.....	57
8	Translation of original declaration of incorporation	63
9	Annex to Declaration of Incorporation.....	64

1 General

1.1 About this manual

This manual contains important information for a safe and appropriate use of the product.

This manual is an integral part of the product and must be kept accessible for the personnel at all times.

Before starting work, the personnel must have read and understood this operating manual. Prerequisite for safe working is the observance of all safety instructions in this manual.

Illustrations in this manual are provided for basic understanding and may differ from the actual product design.

In addition to these instructions, the documents listed under [Applicable documents](#) [► 6] are applicable.

1.1.1 Presentation of Warning Labels

To make risks clear, the following signal words and symbols are used for safety notes.



⚠ DANGER

Danger for persons!

Non-observance will inevitably cause irreversible injury or death.



⚠ WARNING

Dangers for persons!

Non-observance can lead to irreversible injury and even death.



⚠ CAUTION

Dangers for persons!

Non-observance can cause minor injuries.

CAUTION

Material damage!

Information about avoiding material damage.

1.1.2 Applicable documents

- General terms of business *
- Catalog data sheet of the purchased product *
- Assembly and operating manuals of the accessories *
- For ATEX versions: Supplementary sheet "Installation and operating instructions - EX" *

The documents marked with an asterisk (*) can be downloaded on our homepage **schunk.com**

1.1.3 Sizes

This operating manual applies to the following sizes:

- PGN-plus-P 40
- PGN-plus-P 50
- PGN-plus-P 64
- PGN-plus-P 80
- PGN-plus-P 100
- PGN-plus-P 125
- PGN-plus-P 160
- PGN-plus-P 200
- PGN-plus-P 240
- PGN-plus-P 300
- PGN-plus-P 380

1.1.4 Variants

This operating manual applies to the following variations:

- PGN-plus-P stroke 1
- PGN-plus-P stroke 2
- PGN-plus-P with gripping force maintenance "O.D. gripping" (AS)
- PGN-plus-P with gripping force maintenance "I.D. gripping" (IS)
- PGN-plus-P dust-tight (SD)
- PGN-plus-P high-temperature (V/HT)
- PGN-plus-P anti-corrosion (K)
- PGN-plus-P precision (P)
- PGN-plus-P ATEX (EX)

1.2 Warranty

If the product is used as intended, the warranty is valid for 36 months from the ex-works delivery date under the following conditions:

- Observe the ambient conditions and operating conditions, [Ambient conditions and operating conditions](#) [► 10]
- Observe the specified maintenance intervals, [Maintenance](#) [► 48]

Parts touching the workpiece and wear parts are not included in the warranty.

Designation	PGN-plus-P			
	40	50-160	200-240	300-380
Warranty duration [months]	36	36	36	36
or maximum cycles [mil.]	40	30	20	10

* One cycle consists of a complete gripping process: "Open gripper" (release workpiece) and "Close gripper" (grip workpiece).

1.3 Scope of delivery

The scope of delivery includes

- 2-Finger Parallel Gripper PGN-plus-P in the version ordered
- Accessory pack

Content of the accessory pack:

- 2x centering sleeve for gripper fastening
- 4x centering sleeve for finger fastening
- 2 x O-ring for hose-free direct connection

ID.-No. of the accessory pack

Size	ID number	
	PGN-plus-P	PGN-plus-P V/HT
PGN-plus-P 40	5518410	395518410
PGN-plus-P 50	5512043	395512043
PGN-plus-P 64	5512044	395512044
PGN-plus-P 80	5512045	395512045
PGN-plus-P 100	5512046	395512046
PGN-plus-P 125	5512047	395512047
PGN-plus-P 160	5512048	395512048
PGN-plus-P 200	5512049	395512049
PGN-plus-P 240	5513858	395513858
PGN-plus-P 300	5512050	395512050
PGN-plus-P 380	5515137	395515137

1.4 Accessories

A wide range of accessories are available for this product
 For information regarding which accessory articles can be used with the corresponding product variants, see catalog data sheet.

Content of the sealing kit:

- 1x Cylinder piston seal
- 1x Piston rod seal
- 1x Cover gasket

ID.-No. of the seal kit

Size	ID number	
	PGN-plus-P	PGN-plus-P V/HT
PGN-plus-P 40	1342290	1342298
PGN-plus-P 50	1000115	1000116
PGN-plus-P 64	1000117	1000118
PGN-plus-P 80	1000119	1000120
PGN-plus-P 100	1000121	1000122
PGN-plus-P 125	1000123	1000124
PGN-plus-P 160	1342256	1342270
PGN-plus-P 200	1339255	1339273
PGN-plus-P 240	1342278	1342287
PGN-plus-P 300	0370898	0370943
PGN-plus-P 380	0370989	0370990

2 Basic safety notes

2.1 Intended use

The product is designed exclusively for gripping and temporarily holding workpieces or objects.

- The product may only be used within the scope of its technical data, [Technical data](#) [▶ 16].
- When implementing and operating components in safety-related parts of the control systems, the basic safety principles in accordance with DIN EN ISO 13849-2 apply. The proven safety principles in accordance with DIN EN ISO 13849-2 also apply to categories 1, 2, 3 and 4.
- The product is intended for installation in a machine/system. The applicable guidelines must be observed and complied with.
- The product is intended for industrial and industry-oriented use.
- Appropriate use of the product includes compliance with all instructions in this manual.

2.2 Not intended use

It is not intended use if the product is used, for example, as a pressing tool, stamping tool, lifting gear, guide for tools, cutting tool, clamping device or a drilling tool.

- Any utilization that exceeds or differs from the appropriate use is regarded as misuse.

2.3 Constructional changes

Implementation of structural changes

By conversions, changes, and reworking, e.g. additional threads, holes, or safety devices can impair the functioning or safety of the product or damage it.

- Structural changes should only be made with the written approval of SCHUNK.

2.4 Spare parts

Use of unauthorized spare parts

Using unauthorized spare parts can endanger personnel and damage the product or cause it to malfunction.

- Use only original spare parts or spares authorized by SCHUNK.

2.5 Gripper fingers

Requirements of gripper fingers

Accumulated energy can make the product unsafe and risk the danger of serious injuries and considerable material damage.

- Execute the gripper fingers in such a way that the product reaches either the "open" or "closed" position in a de-energized state.
- Only change gripper fingers if no residual energy can be released.
- Make sure that the product and the top jaws are a sufficient size for the application.

2.6 Ambient conditions and operating conditions

Required ambient conditions and operating conditions

Incorrect ambient and operating conditions can make the product unsafe, leading to the risk of serious injuries, considerable material damage and/or a significant reduction to the product's life span.

- Make sure that the product is used only in the context of its defined application parameters, [Technical data](#) [▶ 16].
- Make sure that the product is a sufficient size for the application.
- Make sure that the environment is free from splash water and vapors as well as from abrasion or processing dust. Exceptions are products that are designed especially for contaminated environments.

2.7 Personnel qualification

Inadequate qualifications of the personnel

If the personnel working with the product is not sufficiently qualified, the result may be serious injuries and significant property damage.

- All work may only be performed by qualified personnel.
- Before working with the product, the personnel must have read and understood the complete assembly and operating manual.
- Observe the national safety regulations and rules and general safety instructions.

The following personal qualifications are necessary for the various activities related to the product:

Trained electrician	Due to their technical training, knowledge and experience, trained electricians are able to work on electrical systems, recognize and avoid possible dangers and know the relevant standards and regulations.
Qualified personnel	Due to its technical training, knowledge and experience, qualified personnel is able to perform the delegated tasks, recognize and avoid possible dangers and knows the relevant standards and regulations.
Instructed person	Instructed persons were instructed by the operator about the delegated tasks and possible dangers due to improper behaviour.
Service personnel of the manufacturer	Due to its technical training, knowledge and experience, service personnel of the manufacturer is able to perform the delegated tasks and to recognize and avoid possible dangers.

2.8 Personal protective equipment

Use of personal protective equipment

Personal protective equipment serves to protect staff against danger which may interfere with their health or safety at work.

- When working on and with the product, observe the occupational health and safety regulations and wear the required personal protective equipment.
- Observe the valid safety and accident prevention regulations.
- Wear protective gloves to guard against sharp edges and corners or rough surfaces.
- Wear heat-resistant protective gloves when handling hot surfaces.
- Wear protective gloves and safety goggles when handling hazardous substances.
- Wear close-fitting protective clothing and also wear long hair in a hairnet when dealing with moving components.

2.9 Notes on safe operation

Incorrect handling of the personnel

Incorrect handling and assembly may impair the product's safety and cause serious injuries and considerable material damage.

- Avoid any manner of working that may interfere with the function and operational safety of the product.
- Use the product as intended.
- Observe the safety notes and assembly instructions.
- Do not expose the product to any corrosive media. This does not apply to products that are designed for special environments.
- Eliminate any malfunction immediately.
- Observe the care and maintenance instructions.
- Observe the current safety, accident prevention and environmental protection regulations regarding the product's application field.

2.10 Transport

Handling during transport

Incorrect handling during transport may impair the product's safety and cause serious injuries and considerable material damage.

- When handling heavy weights, use lifting equipment to lift the product and transport it by appropriate means.
- Secure the product against falling during transportation and handling.
- Stand clear of suspended loads.

2.11 Malfunctions

Behavior in case of malfunctions

- Immediately remove the product from operation and report the malfunction to the responsible departments/persons.
- Order appropriately trained personnel to rectify the malfunction.
- Do not recommission the product until the malfunction has been rectified.
- Test the product after a malfunction to establish whether it still functions properly and no increased risks have arisen.

2.12 Disposal

Handling of disposal

The incorrect handling of disposal may impair the product's safety and cause serious injuries as well as considerable material and environmental harm.

- Follow local regulations on dispatching product components for recycling or proper disposal.

2.13 Fundamental dangers

General

- Observe safety distances.
- Never deactivate safety devices.
- Before commissioning the product, take appropriate protective measures to secure the danger zone.
- Disconnect power sources before installation, modification, maintenance, or calibration. Ensure that no residual energy remains in the system.
- If the energy supply is connected, do not move any parts by hand.
- Do not reach into the open mechanism or movement area of the product during operation.

2.13.1 Protection during handling and assembly

Incorrect handling and assembly

Incorrect handling and assembly may impair the product's safety and cause serious injuries and considerable material damage.

- Have all work carried out by appropriately qualified personnel.
- For all work, secure the product against accidental operation.
- Observe the relevant accident prevention rules.
- Use suitable assembly and transport equipment and take precautions to prevent jamming and crushing.

Incorrect lifting of loads

Falling loads may cause serious injuries and even death.

- Stand clear of suspended loads and do not step into their swiveling range.
- Never move loads without supervision.
- Do not leave suspended loads unattended.

2.13.2 Protection during commissioning and operation

Falling or violently ejected components

Falling and violently ejected components can cause serious injuries and even death.

- Take appropriate protective measures to secure the danger zone.
- Never step into the danger zone during operation.

2.13.3 Protection against dangerous movements

Unexpected movements

Residual energy in the system may cause serious injuries while working with the product.

- Switch off the energy supply, ensure that no residual energy remains and secure against inadvertent reactivation.
- Never rely solely on the response of the monitoring function to avert danger. Until the installed monitors become effective, it must be assumed that the drive movement is faulty, with its action being dependent on the control unit and the current operating condition of the drive. Perform maintenance work, modifications, and attachments outside the danger zone defined by the movement range.
- To avoid accidents and/or material damage, human access to the movement range of the machine must be restricted. Limit/prevent accidental access for people in this area due through technical safety measures. The protective cover and protective fence must be rigid enough to withstand the maximum possible movement energy. EMERGENCY STOP switches must be easily and quickly accessible. Before starting up the machine or automated system, check that the EMERGENCY STOP system is working. Prevent operation of the machine if this protective equipment does not function correctly.

2.13.4 Protection against electric shock

Possible electrostatic energy

Components or assembly groups may become electrostatically charged. When the electrostatic charge is touched, the discharge may trigger a shock reaction leading to injuries.

- The operator must ensure that all components and assembly groups are included in the local potential equalisation in accordance with the applicable regulations.
- While paying attention to the actual conditions of the working environment, the potential equalisation must be implemented by a specialist electrician according to the applicable regulations.
- The effectiveness of the potential equalisation must be verified by executing regular safety measurements.

2.14 Notes on particular risks



⚠ DANGER

Risk of fatal injury from suspended loads!

Falling loads can cause serious injuries and even death.

- Stand clear of suspended loads and do not step within their swiveling range.
- Never move loads without supervision.
- Do not leave suspended loads unattended.
- Wear suitable protective equipment.



⚠ WARNING

Risk of injury from objects falling and being ejected!

Falling and ejected objects during operation can lead to serious injury or death.

- Take appropriate protective measures to secure the danger zone.



⚠ WARNING

Risk of injury due to unexpected movements!

If the power supply is switched on or residual energy remains in the system, components can move unexpectedly and cause serious injuries.

- Before starting any work on the product: Switch off the power supply and secure against restarting.
- Make sure, that no residual energy remains in the system.



⚠ WARNING

Risk of injury from crushing and impacts!

Serious injury could occur during the base jaw procedure and when breaking or loosening the gripper fingers.

- Wear suitable protective equipment.
- Do not reach into the open mechanism or the movement area of the product.



⚠ WARNING

Risk of injury from sharp edges and corners!

Sharp edges and corners can cause cuts.

- Use suitable protective equipment.

3 Technical data

Connection data

Designation	PGN-plus-P
Pressure medium	Compressed air, compressed air quality according to ISO 8573-1: 7:4:4
Nominal operating pressure [bar]	6
Minimum pressure [bar] without maintenance of gripping force with maintenance of gripping force	2.5 4
Maximum pressure [bar] without maintenance of gripping force with maintenance of gripping force	8 6.5
Pressure range for air purge [bar]	0.5 – 1

Ambient conditions and operating conditions

Designation	PGN-plus-P
Ambient temperature [°C] min. max.	+5 +90 / V HT: +130
Protection class IP *	40 / SD: 64
Noise emission [dB(A)]	≤ 70

* For use in dirty ambient conditions (e.g. sprayed water, vapors, abrasion or processing dust) SCHUNK offers corresponding product options as standard. SCHUNK also offers customized solutions for special applications in dirty ambient conditions.

More technical data is included in the catalog data sheet. Whichever is the latest version.

4 Design and description

4.1 Design

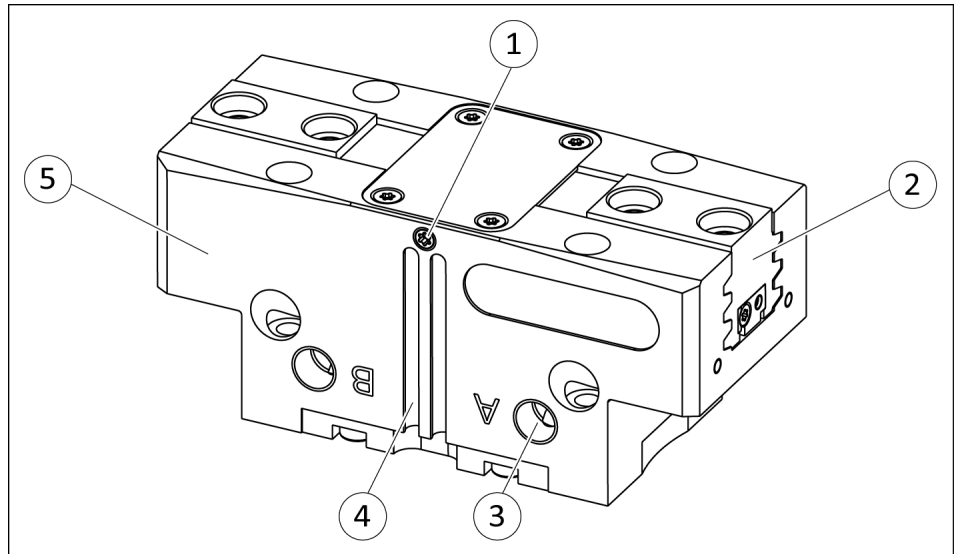

2-Finger Parallel Gripper

1	Air purge connection
2	Base jaw
3	Compressed air main connection
4	Groove for magnetic switch
5	Housing

4.2 Description

Universal 2-finger parallel gripper with large gripping force and high maximum moments thanks to multi-tooth guidance.

5 Assembly

5.1 Installing and connecting



⚠ WARNING

Risk of injury due to unexpected movements!

If the power supply is switched on or residual energy remains in the system, components can move unexpectedly and cause serious injuries.

- Before starting any work on the product: Switch off the power supply and secure against restarting.
- Make sure, that no residual energy remains in the system.

CAUTION

Damage to the gripper is possible!

If the maximum permissible finger weight or the permissible mass moment of inertia of the fingers is exceeded, the gripper can be damaged.

- A jaw movement always has to be without jerks and bounce.
- You must therefore implement sufficient reduction and/or damping.
- Observe the diagrams and information in the catalog data sheet.

1. Check the evenness of the mounting surface, [Mechanical connection](#) [▶ 19].
2. Connect the product via the hose-free direct connection.
3. OR: Connect compressed air lines to the main air connections "A" and "B".
 - ✓ Remove the locking screws.
 - ✓ Screw in air connections (plug connections).
OR: Screw on throttle valve in order to be able to perform sufficient throttling and/or damping.
4. Screw the product to the machine/system, [Mechanical connection](#) [▶ 19].
 - ✓ If necessary, use appropriate connection elements (adapter plates).
 - ✓ Observe permissible depth of engagement and if required strength class.
5. Connect air purge connection if necessary.
6. Attach additional structure to the product if necessary, [Attaching additional structure](#) [▶ 24]
7. Connect the sensor, see assembly and operating manual of the sensor.
8. Mount the sensor, [Mounting the sensor](#) [▶ 26].

Dust-tight (SD)

NOTE

In order to achieve perfect functioning of the gripper, the set-screw of the air purge connection must be removed and replaced with a pneumatic connection when using the dust-tight variant (SD). SCHUNK recommends using the air purge connection within the scope of the technical data, [Technical data](#) [▶ 16].

5.2 Connections

5.2.1 Mechanical connection



⚠ DANGER

Danger of explosion in potentially explosive areas!

- Observe supplementary sheet for products with explosion-resistant versions "PGN-plus-P -...-EX".

Evenness of the mounting surface

The values apply to the whole mounting surface to which the product is mounted.

Requirements for evenness of the mounting surface (Dimensions in mm)

Edge length	Permissible unevenness
< 100	< 0.02
> 100	< 0.05

Connections at the base jaws

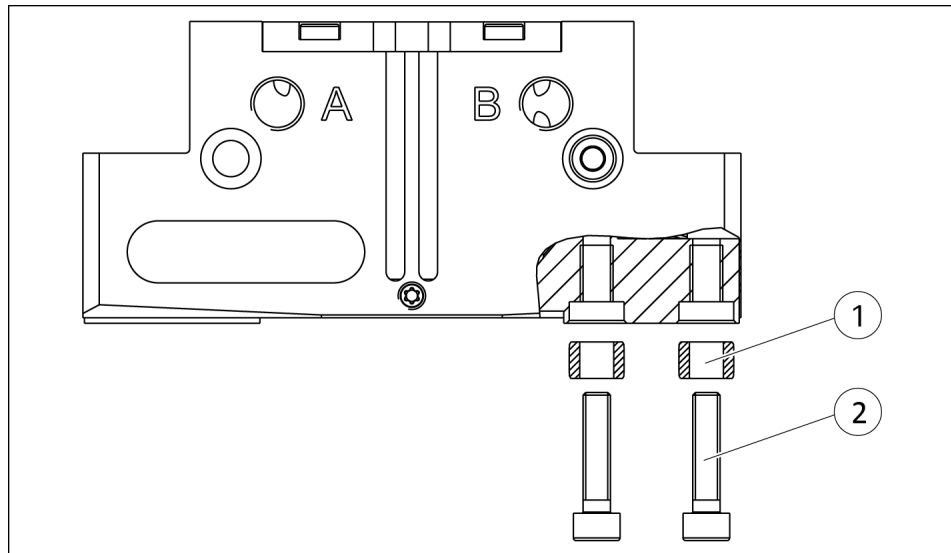

Connections at the base jaws

Item	Mounting	PGN-plus-P					
		40	50	64	80	100	125
1	Centering sleeve	∅4	∅5	∅6	∅8	∅10	∅10
2	Thread in base jaws	M2.5	M3	M4	M5	M6	M6
	Mounting screw strength class	12.9					
	Max. depth of engagement from locating surface [mm]	6.1	8.5	10.7	11.9	14.2	14.2

Item	Mounting	PGN-plus-P				
		160	200	240	300	380
1	Centering sleeve	∅14	∅16	∅16	∅22	∅28
2	Thread in base jaws	M10	M12	M12	M16	M20
	Mounting screw strength class	12.9				
	Max. depth of engagement from locating surface [mm]	17	19.3	21.1	27.9	40

Dust-tight (SD)

NOTE

On delivery of the dust-tight version (SD) the intermediate jaws are screwed onto the base jaws. The intermediate jaws can become off while removing the screws.

Observe during assembly, that the intermediate jaws are between the base jaws und the gripper finger.

Connections at the housing

The product can be mounted from three sides.

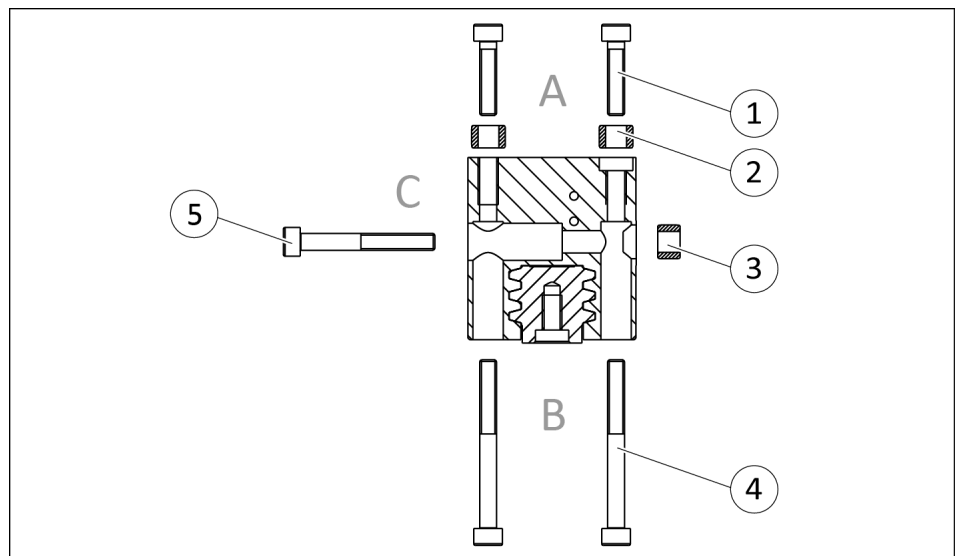

Connections at the housing

Item	Mounting	PGN-plus-P					
		40	50	64	80	100	125
Side A							
1	Mounting screw	M3	M4	M5	M5	M6	M8
	Max. depth of engagement from locating surface [mm]	6	11	12	15	14	20
	for variants IS / AS	6	11	12	15	14	20
2	Centering sleeve	Ø5	Ø6	Ø8	Ø8	Ø10	Ø12
Side B							
4	Bore for mounting screws	M2.5	M3	M4	M4	M5	M6
	Mounting screw according to standard	DIN EN ISO 4762					
2	Centering sleeve	Ø5	Ø6	Ø8	Ø8	Ø10	Ø12
Side C							
5	Bore for mounting screws	M2.5	M3	M4	M5	M6	M8
	Mounting screw according to standard	DIN EN ISO 4762 Max. strength class 8.8					
3	Centering sleeve	Ø5	Ø6	Ø8	Ø8	Ø10	Ø12

Item	Mounting	PGN-plus-P				
		160	200	240	300	380
Side A						
1	Mounting screw	M8	M10	M12	M16	M20
	Max. depth of engagement from locating surface [mm]	20.5	20	25.5	31	38
	for variants IS / AS	20	20	25	31	31
2	Centering sleeve	Ø12	Ø14	Ø16	Ø22	Ø28
Side B						
4	Bore for mounting screws	M6	M8	M10	M12	M16
	Mounting screw according to standard	DIN EN ISO 4762				
2	Centering sleeve	Ø12	Ø12	Ø16	Ø22	Ø28
Side C						
5	Bore for mounting screws	M8	M10	M12	M16	M20
	Mounting screw according to standard	DIN EN ISO 4762 Max. strength class 8.8				
3	Centering sleeve	Ø12	Ø14	Ø16	Ø22	Ø28

Connections for additional structure

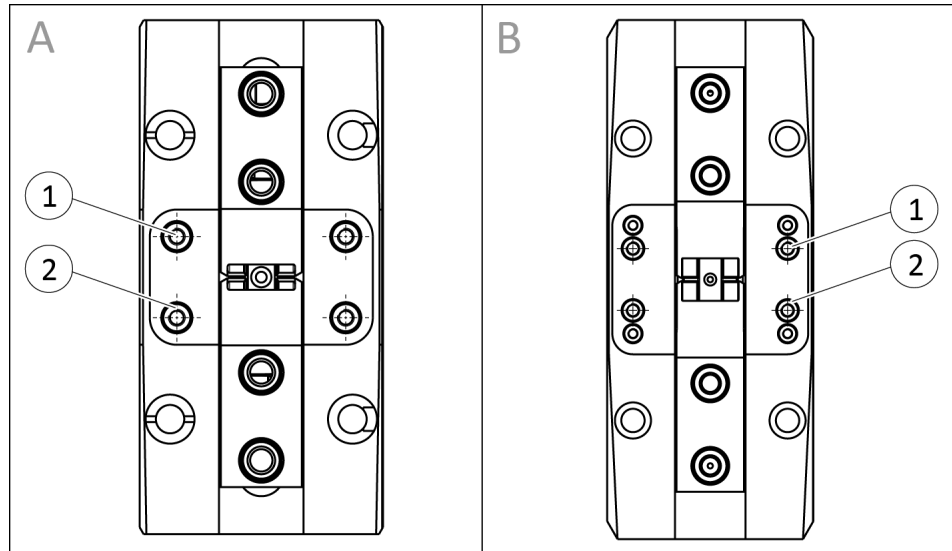

Connections at the housing, sizes: A - to 100, B - from 125

Item	Mounting	PGN-plus-P					
		40	50	64	80	100	125
1	Thread in the housing	M2	M2.5	M2.5	M2.5	M3	M4
	Max. depth of engagement from locating surface [mm]	5	7.1	7.1	7.1	8.4	10.9
2	Centering sleeve	Ø3	Ø4	Ø4	Ø4	Ø5	Ø6

Item	Mounting	PGN-plus-P				
		160	200	240	300	380
1	Thread in the housing	M5	M6	M6	M8	M10
	Max. depth of engagement from locating surface [mm]	13	12	12	12	16
2	Centering sleeve	Ø8	Ø10	Ø10	Ø12	Ø14

5.2.2 Pneumatic connection

NOTE

- Observe the requirements for the compressed air supply, [Technical data](#) [▶ 16].
- In case of compressed air loss (cutting off the energy line), the components lose their dynamic effects and do not remain in a secure position. However, the use of a SDV-P pressure maintenance valve is recommended in this case in order to maintain the dynamic effect for some time. Product variants are also offered with mechanical gripping force via springs, which also ensure a minimum clamping force in the event of a pressure drop.

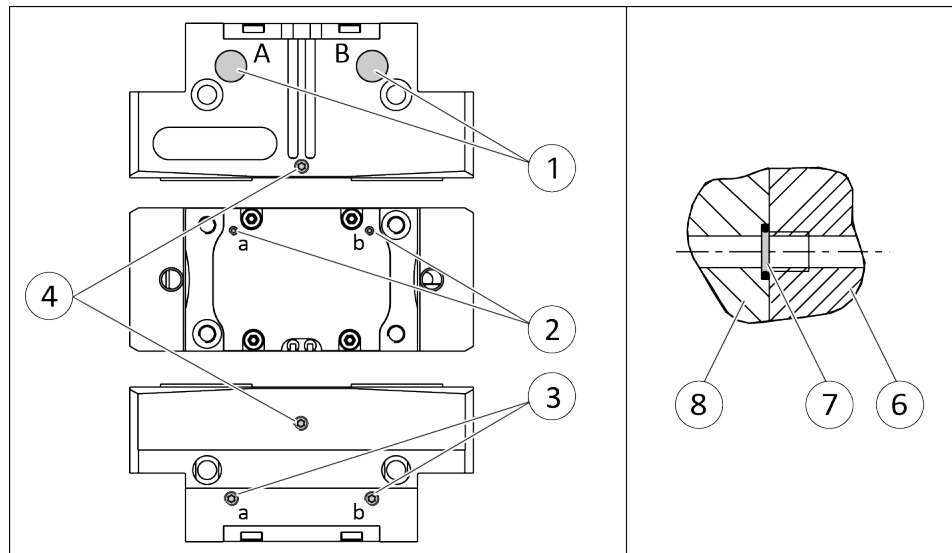

Air connections

1	Main connections (Hose connection) (A = open, B = close)
2	Hose-free direct connection at the base (a = open, b = close)
3	Hose-free direct connection
4	Air purge connection
Hose-free direct connection	
6	Product
7	O-ring
8	Attachment

- Open only the air connections that are needed.
- Close unused main air connections using the screw plugs from the enclosed pack.
- For a hose-free direction connection, use the O-rings from the enclosed pack.

Item	Mounting	PGN-plus-P					
		40	50	64	80	100	125
1	Thread in the main air connections	M3	M5	M5	M5	G1/8	G1/8
	Max. depth of engagement from locating surface [mm]	4	5	6	6	7	7
2	Thread in the air purge connection	M3	M3	M5	M5	M5	M5
	Max. depth of engagement from locating surface [mm]	3.9	5	6	6	6	6

Item	Mounting	PGN-plus-P				
		160	200	240	300	380
1	Thread in the main air connections	G1/8	G1/8	G1/8	G1/4	G1/4
	Max. depth of engagement from locating surface [mm]	7	7	7	12	12
2	Thread in the air purge connection	M5	M5	M5	M5	M5
	Max. depth of engagement from locating surface [mm]	6	6	6	6	6

Air purge connection The air purge is used in order to make it more difficult for dirt and dust to penetrate into the product and the guiding areas. With the dust-tight variant (SD), it is necessary to use the air purge connection in order to achieve the specified protection class.

5.3 Attaching additional structure

NOTE

With the dust-tight variant (SD), no additional structure can be attached.

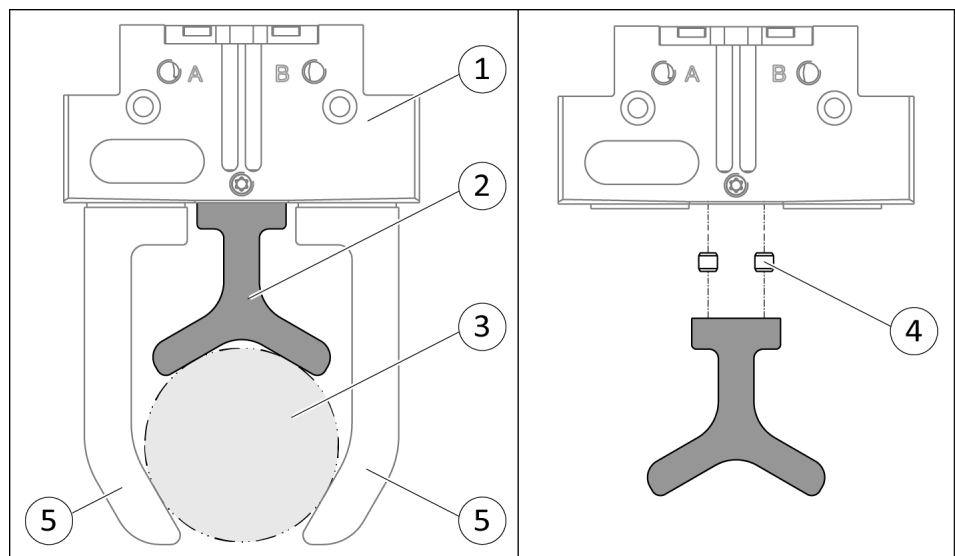

Gripper with additional structure

1	Gripper	4	Centering sleeve
2	Additional structure	5	Gripper fingers
3	Workpiece		

For supporting things like workpieces, an additional structure can be attached to the gripper.

The locating surface of the additional structure may not exceed the recess of the cover. The external dimensions of the additional structure can exceed the external dimensions of the gripper but not interfere with the operating cycle of the gripper fingers.

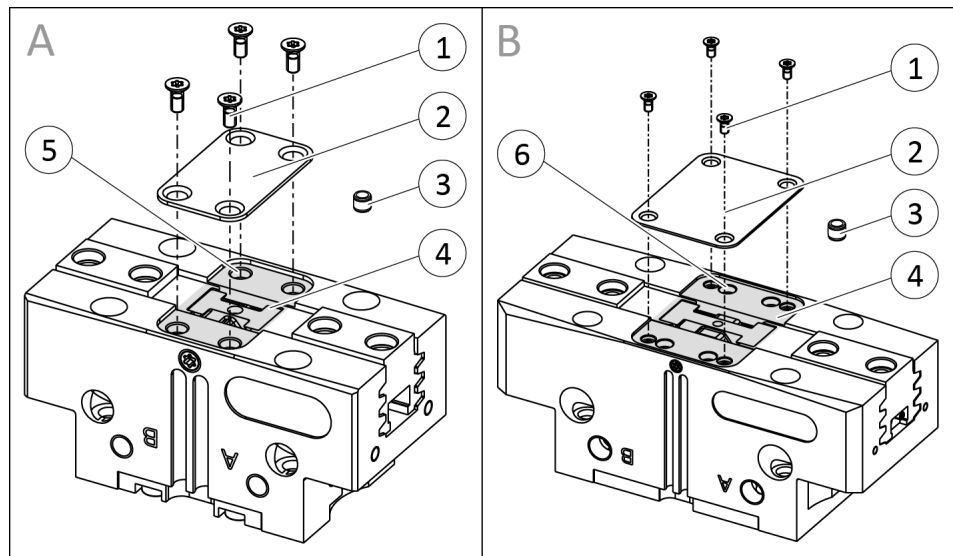

Mounting surface, sizes: A - to 100, B - from 125

1. **IMPORTANT! The size of the additional structure may not exceed the recess of the cover.**
2. Remove the screws (1) from the cover (2).
3. Remove the cover (2).
4. **IMPORTANT! Ensure that no foreign objects can enter the gripper.**
Attach additional structure within the recess (4),
[Mechanical connection](#) [▶ 19].
 - ✓ Use centering sleeves (3) between gripper and additional structure. Centering sleeves can be ordered from SCHUNK.
 - ✓ With sizes 50 – 100 the threaded holes (5) of the cover (2) are used for securing the additional structure.
 - ✓ From size 125, the additionally attached threaded holes (6) are used for securing the additional structure.

5.4 Mounting the sensor

NOTE

Observe the assembly and operating manual of the sensor for mounting and connecting.

The product is prepared for the use of sensors.

- For the exact type designations of suitable sensors, please see catalog datasheet and [Overview of sensors](#) [► 26].
- For technical data for the suitable sensors, see assembly and operating manual and catalog datasheet.
 - The assembly and operating manual and catalog datasheet are included in the scope of delivery for the sensors and are available at schunk.com.
- Information on handling sensors is available at schunk.com or from SCHUNK contact persons.

5.4.1 Overview of sensors

Designation	PGN-plus-P										
	40	50	64	80	100	125	160	200	240	300	380
Inductive proximity switch IN 80	–	–	X	X	X	X	X	X	X	X	X
Magnetic switch MMS 22	X	X	X	X	X	X	X	X	X	X	X
Programmable magnetic switch MMS 22-PI2	X	X	X	X	X	X	X	X	–	–	–
Programmable magnetic switch MMS-P 22	X	X	X	X	X	X	X	X	–	–	–
Programmable magnetic switch MMS 22-PI1	X	X	X	X	X	X	X	X	X	X	X
Magnetic switch MMS 22-IOL	X	X	X	X	X	X	X	–	–	–	–
Analog magnetic switch MMS 22-A	X	X	X	X	X	X	X	X	–	–	–
Analog position sensor APS-Z80	–	–	X	X	X	X	X	X	X	X	X
Flexible position sensor FPS	–	–	X	X	X	X	X	X	X	X *	X *
Analog position sensor APS-M1	–	–	X	X	X	X	X	X	X	X	X

* Only for the "stroke 2" variant.

5.4.2 Setting dimensions for magnetic switches

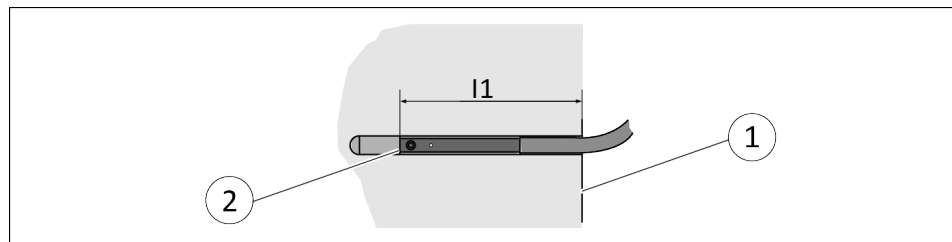

* Setting dimension l_1 , from product bottom edge (1) to front sensor (2)

The setting dimension applies for the following sensors:

- Programmable magnetic switch MMS 22-PI2
- Programmable magnetic switch MMS-P 22
- Programmable magnetic switch MMS 22-PI1
- Magnetic switch MMS 22-IOL
- Analog magnetic switch MMS 22-A

Size	l_1^* [mm]	Size	l_1^* [mm]
40	11.9	100	27
40 AS	11.9	100 AS	27
40 IS	21.9	100 IS	53
50	22	125	30
50 AS	22	125 AS	30
50 IS	38	125 IS	60
64	17.8	160	38
64 AS	17.8	160 AS	33.5
64 IS	35.8	160 IS	78.5
80	25.8	200	40.5
80 AS	25.8	200 AS	34
80 IS	43.8	200 IS	92.2

NOTE

The magnetic switch MMS 22-PI1 can be adjusted and taught in two ways.

- "Standard mode" allows for quick installation on the T-nut preset by SCHUNK in the groove or the defined setting dimension " l_1 ."
- In "Optimal Mode", the sensor identifies the optimal position in the groove itself.
SCHUNK recommends "Optimal Mode" for setting the sensors.

Further information on the installation of the sensor, [Mounting MMS 22-PI1 programmable magnetic switch](#) [► 35]

5.4.3 Switch-off hysteresis for magnetic switches

Sensors MMS 22, MMS-P 22, MMS 22-PI1 and MMS 22-PI2

The smallest detectable difference in stroke is defined in the following table:

The smallest detectable difference in stroke based on the nominal stroke

For grippers with X mm nominal stroke per jaw	Min. query range per jaw/ min. queried stroke difference per jaw
$X \leq 5$ mm	30% of the nominal stroke per jaw
$X > 5$ mm to $X \leq 10$ mm	20% of the nominal stroke per jaw
$X > 10$ mm	10% of the nominal stroke per jaw

Example: Product with 7 mm nominal stroke per jaw

$7 \text{ mm} * 20\% = 1.4 \text{ mm}$

5.4.4 Setting dimensions for position sensors

The setting dimension applies to the following sensors: FPS, APS-M1, APS-Z80

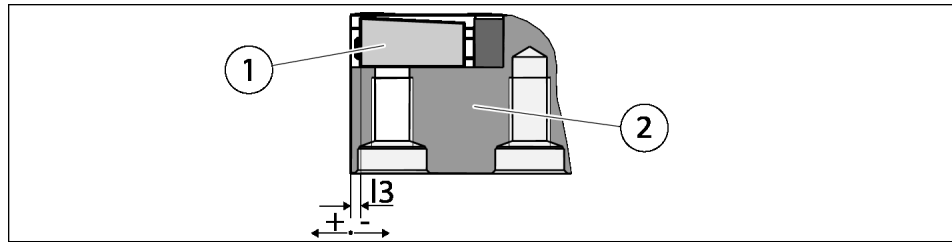

Setting dimension l3 of the base jaw (2) up to the front of the control cam (1)

Size	Setting dimension l3 [mm]		
	FPS	APS-M1	APS-Z80
64-1	-0.8	0	+0.7
64-2	-1.1	0	-3.8
80-1	-2	0	0
80-2	-2.6	0	-3.3
100-1	-2.7	0	-1
100-2	-3	0	-3.8
125-1	-3.8	0	+1.7
125-2	-7.8	0	-2.3
160-1	0	0	0
160-2	-4.2	0	-7.1
200-1	+2.2	0	0
200-2	-7.5	0	-3.6
240-1	+4	0	+3
240-2	-8.2	0	-4.6
300-1	-	0	0
300-2	-12.3	0	-8.8
380-1	-	0	0
380-2	-18.9	0	-16.5

5.4.5 Mounting inductive proximity switch IN

NOTE

The sensor cannot be used for sizes smaller than size 64.

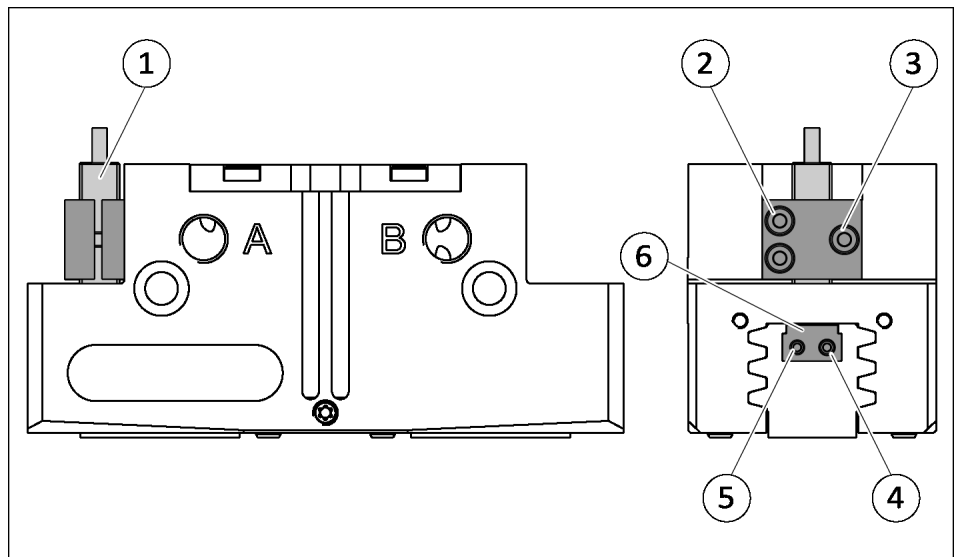

Position "Gripper open" or "Gripper closed"

1. **Variant dust-protection (SD):** Remove the sealing bolts from the brackets.
2. Slide the sensor 1 (1) through the bracket (2) and into the housing until it stops.
3. Tighten the screw (3) on the bracket (2).
Tightening torque: 0.2 Nm
4. Bring product into the "open" or "closed" position and test the function.

Position "Part gripped (O.D. gripping)" or "Part gripped (I.D. gripping)"

1. **Variant dust-protection (SD):** remove the sealing bolts from the bracket and unscrew the set-screw from the side cover.
2. Slide the sensor 1 (1) through the bracket (2) and into the housing until it stops.
3. Tighten the screw (3) on the bracket (2).
Tightening torque: 0.2 Nm
4. Clamp the part to be gripped.
5. Loosen expander bolt (4) by unscrewing it from the control cam (6).

6. Turn adjustable spindle (5) in order to adjust the position of the control cam (6).
 - ✓ **Part gripped (O.D. gripping):**
Slide control cam (6) outwards until the sensor (1) no longer responds.
 - ✓ Move the control cam (6) back towards the inside until the sensor (1) begins to switch.
 - ✓ **Part gripped (I.D. gripping):**
Slide control cam (6) inwards until the sensor (1) no longer responds.
 - ✓ Move the control cam (6) back towards the outside until the sensor (1) begins to switch.
7. Screw the expander bolt (4) back in to fix the switching point.
For tightening torque see following table
8. Open the product and close it again in order to test its function.
9. **Variant dust-protection (SD):** Screw in set-screw into the side cover.

Item	Mounting	PGN-plus-P								
		64	80	100	125	160	200	240	300	380
4	Max. tightening torque [Nm]	0.2	0.2	0.3	0.3	0.4	0.4	0.4	0.4	0.4
5	Max. adjusting torque [Nm]	0.2	0.2	0.3	0.3	0.4	0.4	0.4	0.4	0.4

5.4.6 Mounting MMS 22 magnetic switch

CAUTION

Risk of damage to the sensor during assembly!

- Observe the maximal tightening torque.

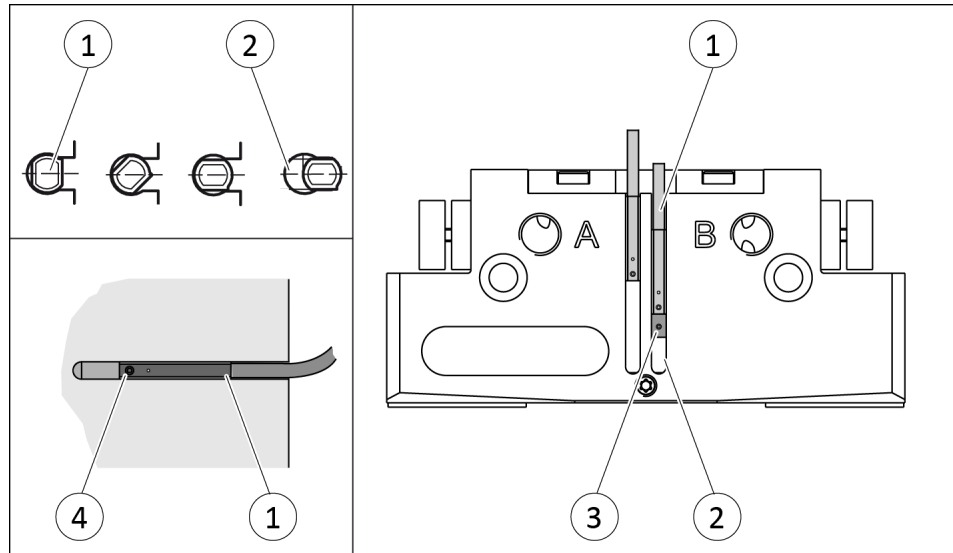

Position "Gripper open" or "Part gripped (I.D. gripping)"

1. Bring product in the position to be set.
2. If necessary remove T-nut (3).
3. Turn the sensor 1 (1) into the groove (2).
OR: Slide the sensor 1 (1) into the groove (2) until the sensor 1 (1) stops at the end of the groove.
4. Pull the sensor 1 (1) back again slowly until it switches.
5. Secure the sensor 1 (1) using the set-screw (4).
Tightening torque: 10 Ncm
6. Bring product into the "Gripper open" or "Part gripped" position and test the function.

Position "Gripper closed" or "Part gripped (O.D. gripping)"

1. Bring product in the position in which it is to be set.
2. If necessary remove T-nut (3).
3. Turn the sensor 2 (1) into the groove (2).
OR: Slide sensor 2 (1) into the groove (2) in the direction of the housing middle (3), until the sensor 2 (1) switches.
4. Secure the sensor 2 (1) using the set-screw (4).
Tightening torque: 10 Ncm
5. Bring product into the "Gripper closed" or "Part gripped" position and test the function.

5.4.7 Mounting programmable MMS 22-PI2 magnetic switch

CAUTION

Risk of damage to the sensor during assembly!

- Observe the maximal tightening torque.

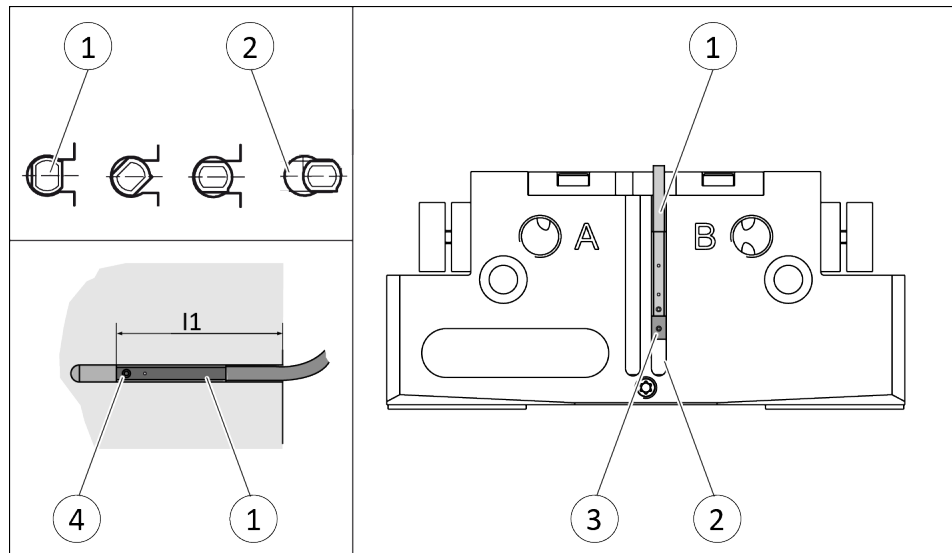

NOTE

If there is no T-nut available, slide the sensor according to dimension l_1 into the groove (2),

[Setting dimensions for magnetic switches](#) [▶ 27].

1. Turn the sensor (1) into the groove (2).
OR: Slide the sensor (1) into the groove (2) until the sensor (1) stops at the T-nut (3).
2. Secure the sensor (1) using the set-screw (4).
Tightening torque: 10 Ncm
3. Adjust sensor (1), see sensor assembly and operating manual.

5.4.8 Mounting programmable MMS 22-P 22 magnetic switch

CAUTION

Risk of damage to the sensor during assembly!

- Observe the maximal tightening torque.

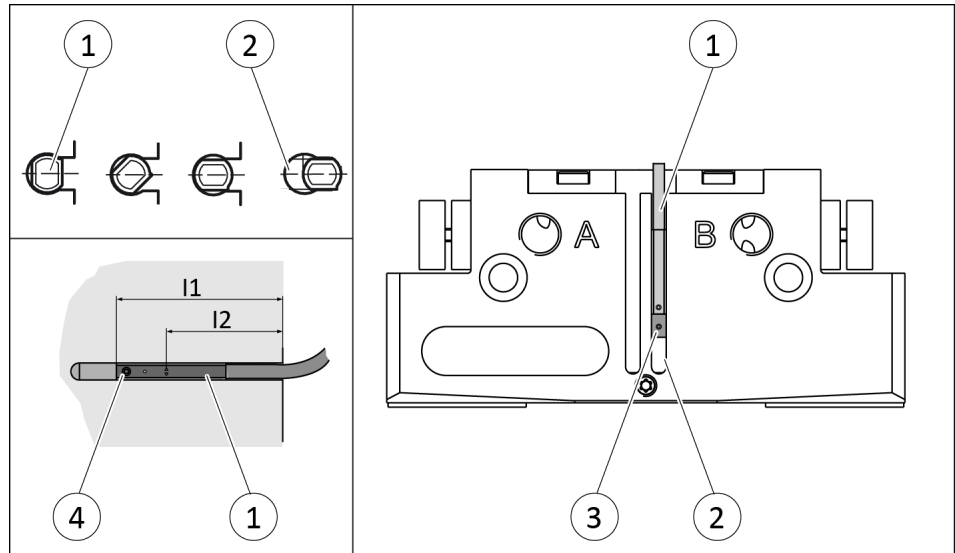

NOTE

If there is no T-nut available, slide the sensor according to dimension l1 into the groove (2),

[Setting dimensions for magnetic switches](#) [▶ 27].

1. Turn the sensor (1) into the groove (2).
OR: Slide the sensor (1) into the groove (2) until the sensor (1) stops at the T-nut (3).
2. Secure the sensor (1) using the set-screw (4).
Tightening torque: 10 Ncm
3. Adjust sensor (1), see sensor assembly and operating manual.

5.4.9 Mounting MMS 22-PI1 programmable magnetic switch

CAUTION

Risk of damage to the sensor during assembly!

- Observe the maximal tightening torque.

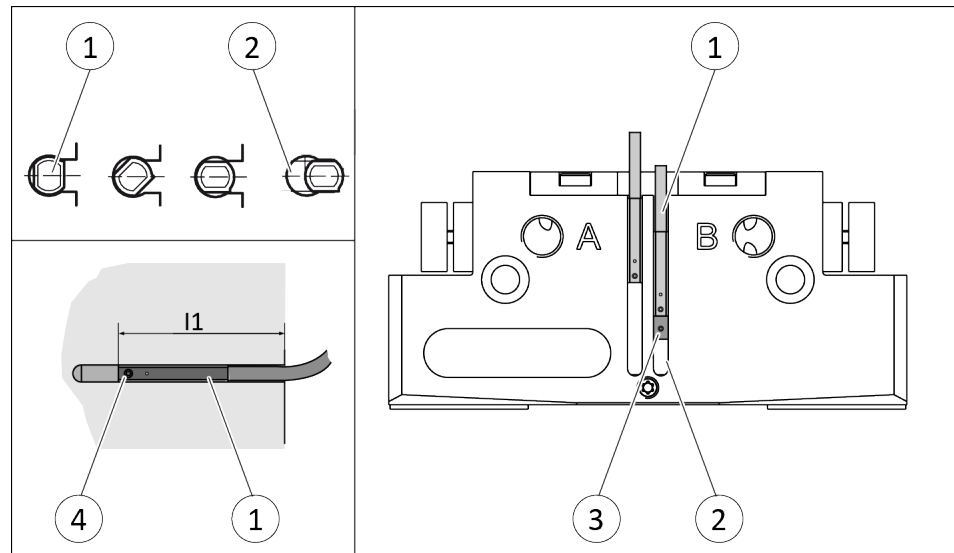

NOTE

If there is no T-nut available, slide the sensor according to dimension l_1 into the groove (2),

[Setting dimensions for magnetic switches](#) [▶ 27].

NOTE

The magnetic switch MMS 22-PI1 can be adjusted and taught in two ways.

- "Standard mode" allows for quick installation on the T-nut preset by SCHUNK in the groove or the defined setting dimension "l1."
- In "Optimal Mode", the sensor identifies the optimal position in the groove itself.
SCHUNK recommends "Optimal Mode" for setting the sensors.

Setting the sensor in "Optimum mode"

1. Put product in the position in which it is to be set.
2. Hold teaching tool to the sensor 1 (1) until the sensor flashes.
3. Slide sensor 1 (1) into the groove (2), until the sensor 1 flashes rapidly.
 - ✓ The optimum position is displayed.
4. Secure the sensor 1 (1) using the set-screw (4).
Tightening torque: 10 Ncm
5. Hold teaching tool to the sensor 1 (1) to confirm the position.
 - ✓ The sensor 1 (1) has been taught in.
6. Repeat steps for sensor 2.

Alternatively for size 40 – 160, except size 50:

Setting the sensor in "Standard mode"

1. Turn the sensor 1 (1) into the groove (2).
OR: Slide the sensor 1 (1) into the groove (2) until the sensor 1 (1) stops at the T-nut (3).
2. Secure the sensor 1 (1) using the set-screw (4).
Tightening torque: 10 Ncm
3. Adjust sensor 1 (1), see sensor assembly and operating manual.
4. Repeat steps for sensor 2.

NOTE

If there is no T-nut available, slide the sensor according to dimension l1 into the groove (2), [Setting dimensions for magnetic switches](#) [▶ 27].

5.4.10 Mounting the magnetic switch MMS 22-IOL

CAUTION**Risk of damage to the sensor during assembly!**

- Observe the maximal tightening torque.

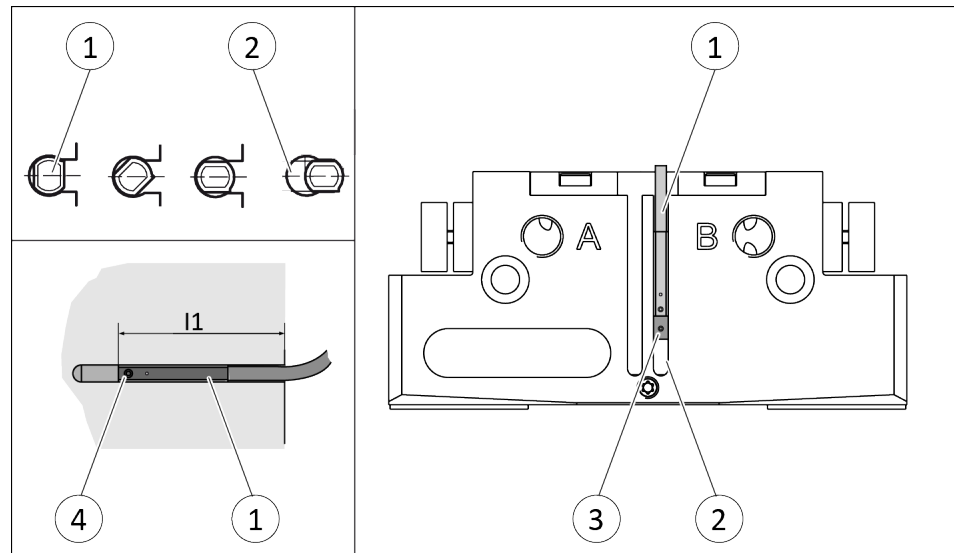
**NOTE**

If there is no T-nut available, slide the sensor according to dimension l_1 into the groove (2),

[Setting dimensions for magnetic switches](#) [▶ 27].

1. Turn the sensor (1) into the groove (2).
OR: Slide the sensor (1) into the groove (2) until the sensor (1) stops at the T-nut (3).
2. Secure the sensor (1) using the set-screw (4).
Tightening torque: 10 Ncm
3. Adjust sensor (1), see sensor assembly and operating manual.

5.4.11 Mounting analog MMS 22-A magnetic switch

CAUTION

Risk of damage to the sensor during assembly!

- Observe the maximal tightening torque.

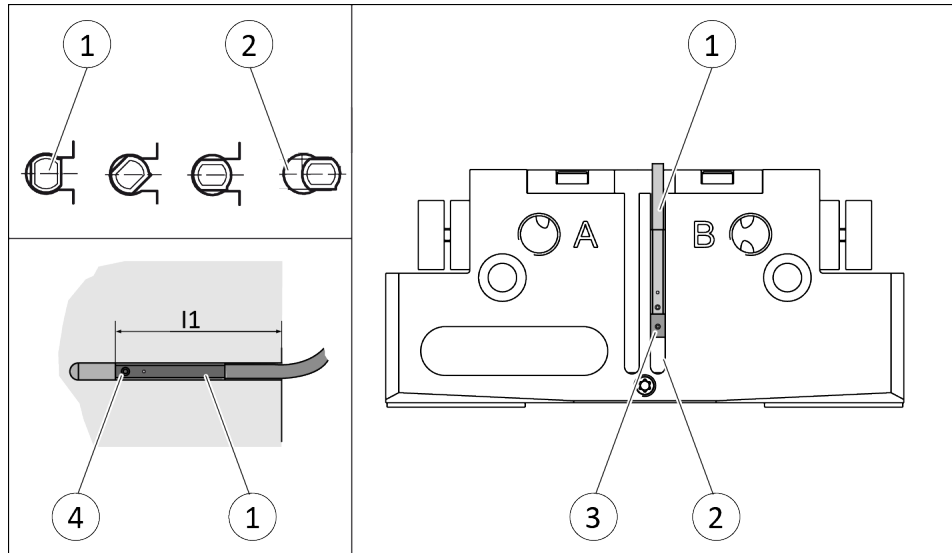

NOTE

If there is no T-nut available, slide the sensor according to dimension l_1 into the groove (2), [Setting dimensions for magnetic switches](#) [▶ 27].

Sizes 40, 64, 80, 100, 125, 160, 200

1. Turn the sensor (1) into the groove (2).
OR: Slide the sensor (1) into the groove (2) until the sensor (1) stops at the T-nut (3).
2. Secure the sensor (1) using the set-screw (4).
Tightening torque: 10 Ncm
3. Adjust sensor (1), see sensor assembly and operating manual.

Sizes 50, 200

During the monitoring, the first and last 15% of the nominal stroke will not produce a change in the analog signal. It is therefore not possible to monitor the end positions. If you have questions, please contact SCHUNK.

Size	Stroke 1		Stroke 2	
	100%	15%	100%	15%
PGN-plus-P 50	4 mm	0.6 mm	2 mm	0.3 mm
PGN-plus-P 200	25 mm	3.75 mm	14 mm	2.1 mm

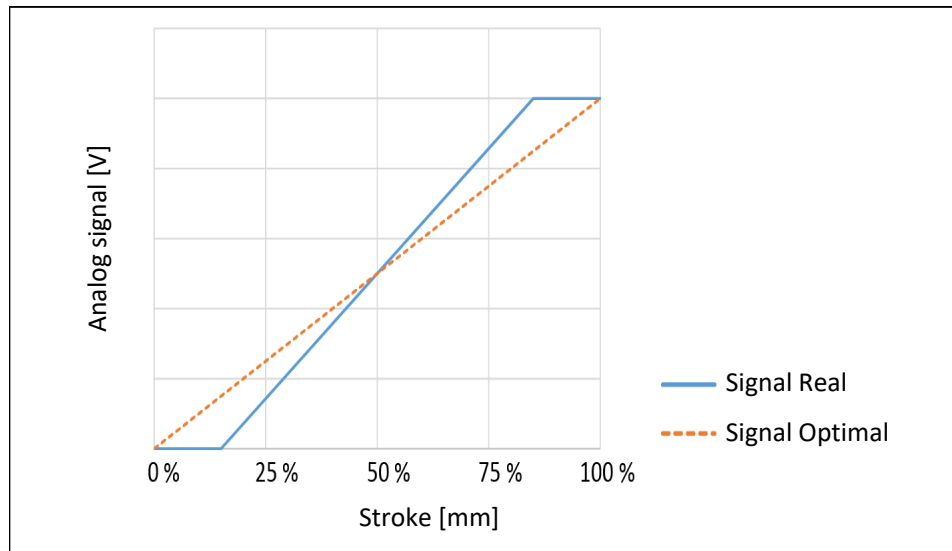

1. Turn the sensor (1) into the groove (2).
OR: Slide the sensor (1) into the groove (2) until the sensor (1) stops at the T-nut (3).
2. Secure the sensor (1) using the set-screw (4).
Tightening torque: 10 Ncm

NOTE

Only valid for size 50.

The gripper is too fast without throttling, which means that teaching the sensor does not work reliably. Fixed throttle valves or other throttle valves with a diameter of 0.8 mm can be used for the teaching process.

ID number throttle reduction M5 - 0.8: 9953035

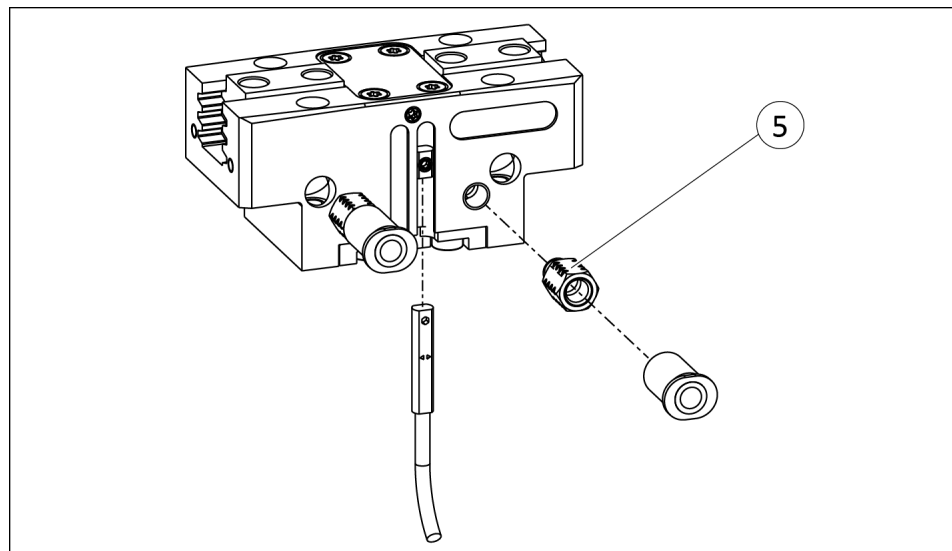

3. Mount a throttle reduction M5 - 0.8 (5) at both main connections "A" and "B".
4. Adjust sensor (1), see Translation of Sensor Assembly and Operating Manual.
5. Remove throttle reduction (5) after finishing the sensor teaching process.

5.4.12 Mounting analog position sensor APS-Z80

To be able to mount the sensor, the gripper has to be retrofitted with a special mounting kit.

During the monitoring process, the first 8% of the nominal stroke will not produce a change in the analog signal. With O.D. gripping the "Gripper closed" position and with I.D. gripping the "Gripper opened" position cannot be queried. Should you have questions, do not hesitate to contact SCHUNK.

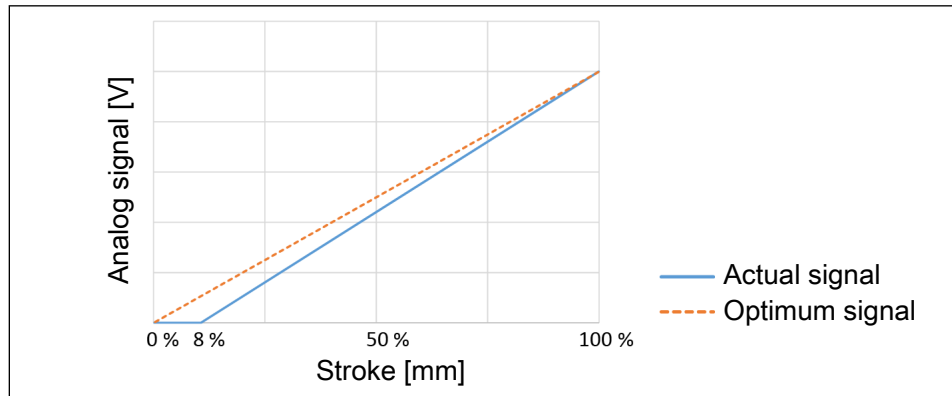

Analog signal on O.D. gripping

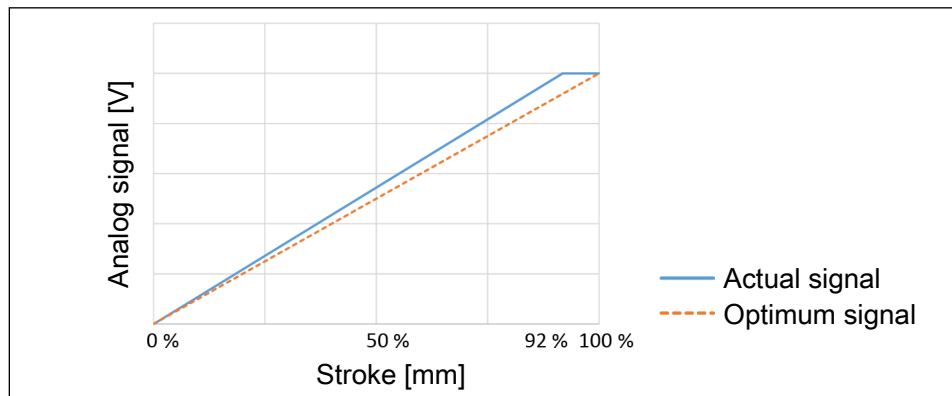

Analog signal on I.D. gripping

Variant Dust-tight:

Before attaching the sensor, remove the sealing bolts from the bracket. Before adjusting the control cam, unscrew the set-screw from the side cover.

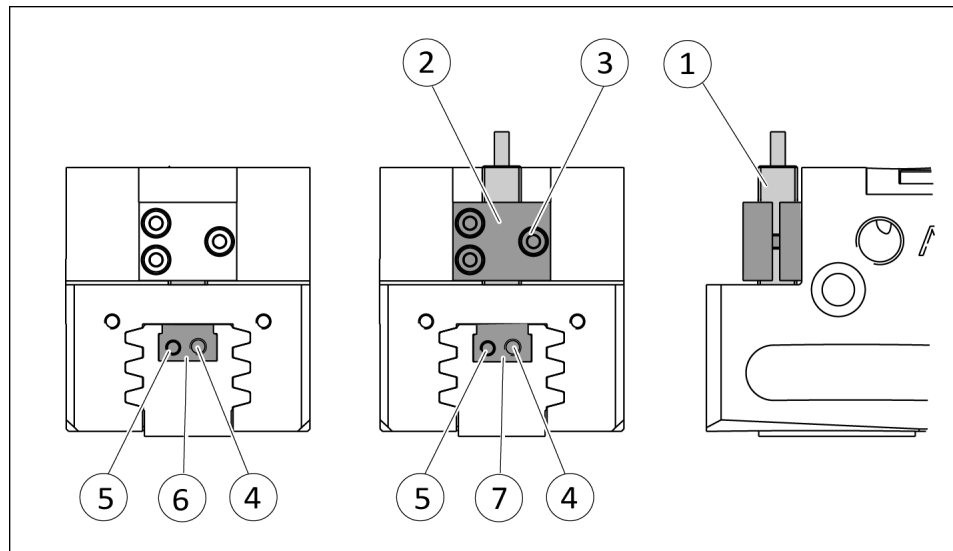

1. Move product to the "gripper open" position.
2. Loosen clamping spindle (4) and remove the switching cam (6) for inductive sensing from the base jaw by turning the adjusting spindle (5).
3. Slide control cam (7) from the mounting kit into the base jaw.
 - ✓ Ensure that the higher front side of the control cam (6) is pointing outwards.
4. Screw the switching cam (7) into the base jaw by turning the adjusting spindle (5) until the adjustment dimension I3 is reached [Setting dimensions for position sensors](#) [► 29].
5. Fix the control cam (7) with the clamping spindle (4). It must not be possible to move the control cam after assembly.
6. Slide the sensor (1) to the stop into the bracket (2).
7. Tighten the screw (3) on the bracket (2).
Tightening torque: 0.2 Nm
8. Connect the sensor, see assembly and operating manual of the sensor.

Variant Dust-tight:

Screw in set-screw into the side cover.

5.4.13 Mount the flexible position sensor FPS

The flexible position sensor FPS consists of an evaluation unit and one of the following sensors:

- MMS 22-A-5V
- FPS-S M8

CAUTION

Risk of damage to the sensor during assembly!

- Observe the maximal tightening torque.
-

5.4.13.1 Mounting the MMS 22-A-5V

Note: In order to mount the sensor MMS 22-A-5V, no additional attachment kit is required.

1. Assembling the sensor,
[Mounting analog MMS 22-A magnetic switch \[▶ 38\]](#) .
2. Connect the control unit output and adjust the sensor (see assembly and operating manual of the sensor).

5.4.13.2 Mounting FPS-M8

To be able to mount the sensor, the gripper has to be retrofitted with a special mounting kit.

Variant Dust-tight:

Before attaching the sensor, remove the sealing bolts from the bracket. Before adjusting the control cam, unscrew the set-screw from the side cover.

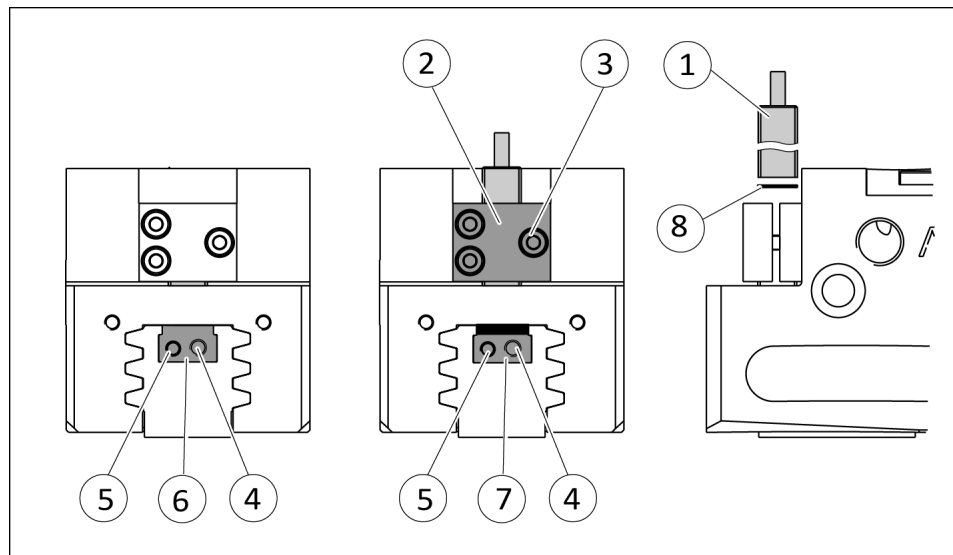

1. Move product to the "gripper open" position.
2. Loosen clamping spindle (4) and remove the switching cam (6) for inductive sensing from the base jaw by turning the adjusting spindle (5).
3. Slide control cam (7) from the mounting kit into the base jaw.
4. Screw the switching cam (7) into the base jaw by turning the adjusting spindle (5) until the adjustment dimension I3 is reached [Setting dimensions for position sensors](#) [▶ 29].
5. Fix the control cam (7) with the clamping spindle (4). It must not be possible to move the control cam after assembly.
6. **For sizes 125-1, 200-1 and 200-2:** Slide spacer (8) into the bracket (2) to the stop.
7. Slide the sensor (1) to the stop into the bracket (2).
8. Tighten the screw (3) on the bracket (2).
Tightening torque: 0.2 Nm
9. Adjust sensor (1), see assembly and operating manual of the sensor.

5.4.14 Mounting analog position sensor APS-M1

To be able to mount the sensor, the gripper has to be retrofitted with a special mounting kit.

For sizes 64 and 80, the clamping brackets from the mounting kit must be mounted.

Variant Dust-tight:

Before attaching the sensor, remove the sealing bolts from the bracket. Before adjusting the control cam, unscrew the set-screw from the side cover.

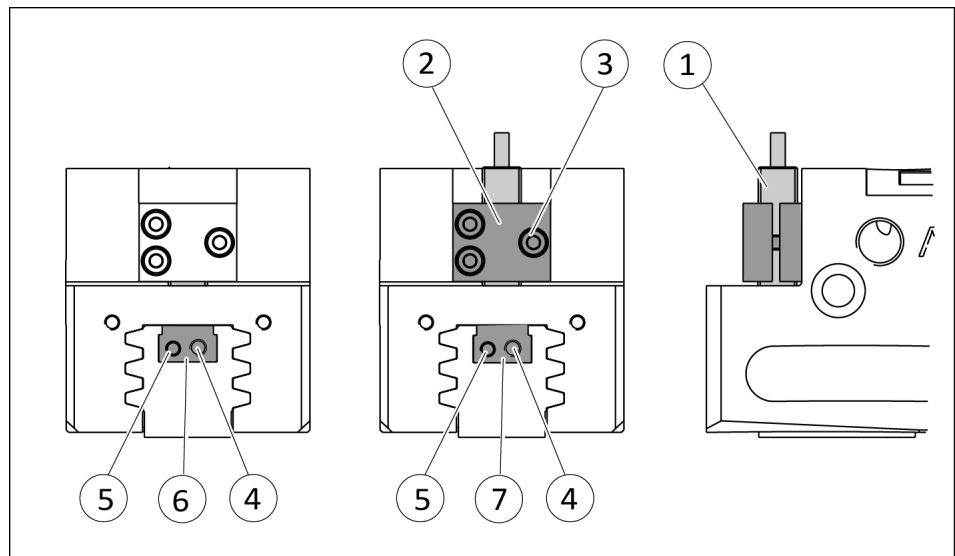

1. Move product to the "gripper open" position.
2. Loosen clamping spindle (4) and remove the switching cam (6) for inductive sensing from the base jaw by turning the adjusting spindle (5).
3. Slide control cam (7) from the mounting kit into the base jaw.
 - ✓ Ensure that the higher front side of the control cam (6) is pointing outwards.
4. Screw the switching cam (7) into the base jaw by turning the adjusting spindle (5) until the adjustment dimension I3 is reached [Setting dimensions for position sensors](#) [▶ 29].
5. Fix the control cam (7) with the clamping spindle (4). It must not be possible to move the control cam after assembly.
6. Slide the sensor (1) to the stop into the bracket (2).
7. Tighten the screw (3) on the bracket (2).
Tightening torque: 0.2 Nm
8. Connect the sensor, see assembly and operating manual of the sensor.

Variant Dust-tight:

Screw in set-screw into the side cover.

6 Troubleshooting

6.1 Product does not move

Possible cause	Corrective action
Base jaws jam in housing, e.g. mounting surface is not sufficiently even.	Check the evenness of the mounting surface. Mechanical connection [▶ 19]
Pressure drops below minimum.	Check air supply. Technical data [▶ 16]
Compressed air lines switched.	Check compressed air lines. Pneumatic connection [▶ 22]
Proximity switch defective or set incorrect.	Readjust or change sensor.
Unused air connections open.	Close unused air connections.
Flow control valve closed.	Open the flow control valve.
Component part defective.	Replace component or send it to SCHUNK for repair.
Subsequent assembly of the dust-protection mounting kit.	Move base jaws several cycles with maximum operating pressure.

6.2 Product is not executing the complete stroke

Possible cause	Corrective action
Dirt deposits between cover and piston.	Clean and if necessary re-lubricate. Maintenance [▶ 48]
Dirt deposits between basic jaws and guidance.	Disassemble and clean the product.
Pressure drops below minimum.	Check air supply. Pneumatic connection [▶ 22]
Mounting surface is not sufficiently flat.	Check the evenness of the mounting surface. Mechanical connection [▶ 19]
Component part defective.	Replace component or send it to SCHUNK for repair.
Subsequent assembly of the dust-protection mounting kit.	Move base jaws several cycles with maximum operating pressure.

6.3 Product opens or closes abruptly

Possible cause	Corrective action
Too little grease in the mechanical guiding areas.	Clean and lubricate product. Maintenance [▶ 48]
Compressed air lines blocked.	Check compressed air lines of damage.
Mounting surface is not sufficiently flat.	Check the evenness of the mounting surface.
One-way flow control valve is missing or adjustet incorrectly.	Install and adjust one-way flow control valve.
Loading too large.	Check permissible weight and length of the gripper fingers.
Subsequent assembly of the dust-protection mounting kit.	Move base jaws several cycles with maximum operating pressure.

6.4 Product does not achieve the opening and closing times

Possible cause	Corrective action
Compressed air lines are not installed optimally.	If present: Open the flow control couplings on the product to the maximum that the movement of the jaws occurs without bouncing and hitting.
	Check compressed air lines.
	Inner diameters of compressed air lines are of sufficient size in relation to compressed air consumption.
	Flow rate of valve is sufficiently large relative to the compressed air consumption.
	If, despite optimum air connections, the opening and closing times specified in the catalogue are not achieved, SCHUNK recommends the use of quick-air-vent-valves directly at the product.
Compressed air can escape.	Check seals, if necessary, disassemble the product and replace seals.
Component part defective.	Replace component or send it to SCHUNK for repair.
Too much grease in the mechanical movement space.	Clean and lubricate product. Maintenance [▶ 48]
Loading too large.	Check permissible weight and length of the gripper fingers.
Subsequent assembly of the dust-protection mounting kit.	Move base jaws several cycles with maximum operating pressure.

6.5 Gripping force is dropping

Possible cause	Corrective action
Compressed air can escape.	Check seals, if necessary, disassemble the product and replace seals.
Too much grease in the mechanical movement space.	Clean and lubricate product.
Pressure drops below minimum.	Check air supply. Pneumatic connection [▶ 22]
Component part defective.	Replace component or send it to SCHUNK for repair.

7 Maintenance

7.1 Notes



⚠ DANGER

Danger of explosion in potentially explosive areas!

- Observe supplementary sheet for products with explosion-resistant versions "PGN-plus-P -...-EX".

Original spare parts

Use only original spare parts of SCHUNK when replacing spare and wear parts.

Exchange of housing and base jaws

The base jaws and the guidance in the housing are matched. To exchange these parts, send the product with a repair order to SCHUNK or order the housing with the base jaws as a set.

7.2 Maintenance intervals

If products are used at room temperature and the ambient and operating conditions are adhered to, these variants are maintenance-free, [Technical data](#) [▶ 16].

Products for special ambient conditions are excluded, e.g. higher temperatures, dirty environment.

If products are not used at room temperature or in special ambient conditions, the following maintenance intervals apply

Interval (million cycles)	Maintenance work
10	Clean the product dry without a degreasing agent, check for damage and wear.
10	If necessary: Replace seals, Replace seals [▶ 50].
10	Treat all grease areas with lubricant, Lubricants/Lubrication points (basic lubrication) [▶ 49], Lubricate product [▶ 49]

For extreme ambient and application conditions, shortened maintenance cycles can ensure the lifespan is maintained.

CAUTION

Material damage due to hardening lubricants!

Lubricants harden more quickly at temperatures above 60°C, leading to possible product damage.

- Reduce the lubricant intervals accordingly.

7.3 Lubricants/Lubrication points (basic lubrication)

SCHUNK recommends the lubricants listed.

During maintenance, treat all greased areas with lubricant. Thinly apply lubricant with a lint-free cloth.

Lubricant point	Lubricant
Metallic sliding surfaces	PGN-plus-P 40: microGLEIT GSV 790 PGN-plus-P 50-380: Toothgood 1
All seals	Sealgood 1
Cylinder surfaces	Sealgood 1

7.4 Lubricate product



⚠ WARNING

Risk of injury due to moving parts!

When moving the gripper fingers, body parts may get squashed/hit causing severe injuries.

- Do not interfere with moving parts during operation.
- Observe position and direction of movement of the gripper fingers.

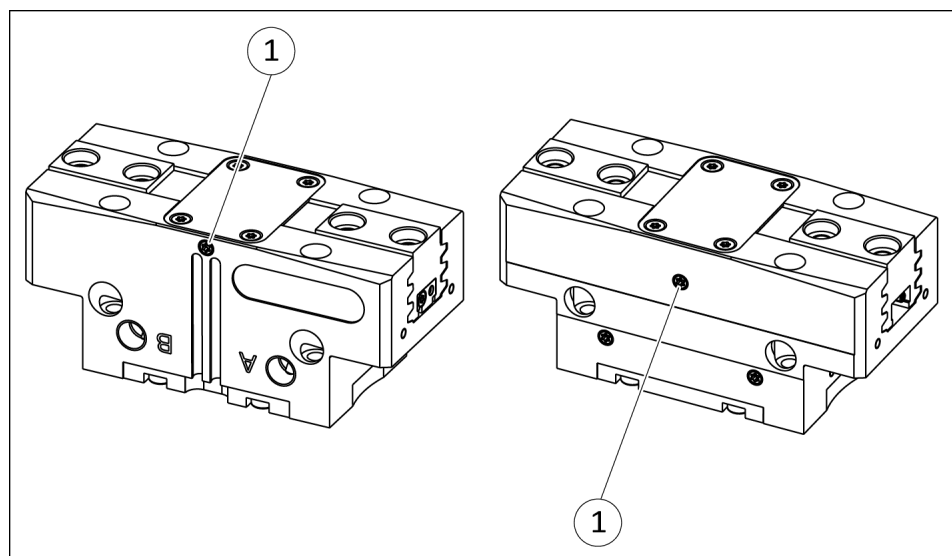

1. Remove set-screw on an air purge connection (1).
2. Screw in lubrication nipple.
3. Apply a layer of grease to metallic sliding surfaces of the gripper using the lubrication nipple, [Lubricants/Lubrication points \(basic lubrication\)](#) [▶ 49].
✓ While lubricating, completely open and close the gripper alternately.
4. Unscrew the lubrication nipple.
5. Screw set-screws into both air purge connections (1).

7.5 Replace seals

7.5.1 Replace seal (variant without gripping force maintenance)

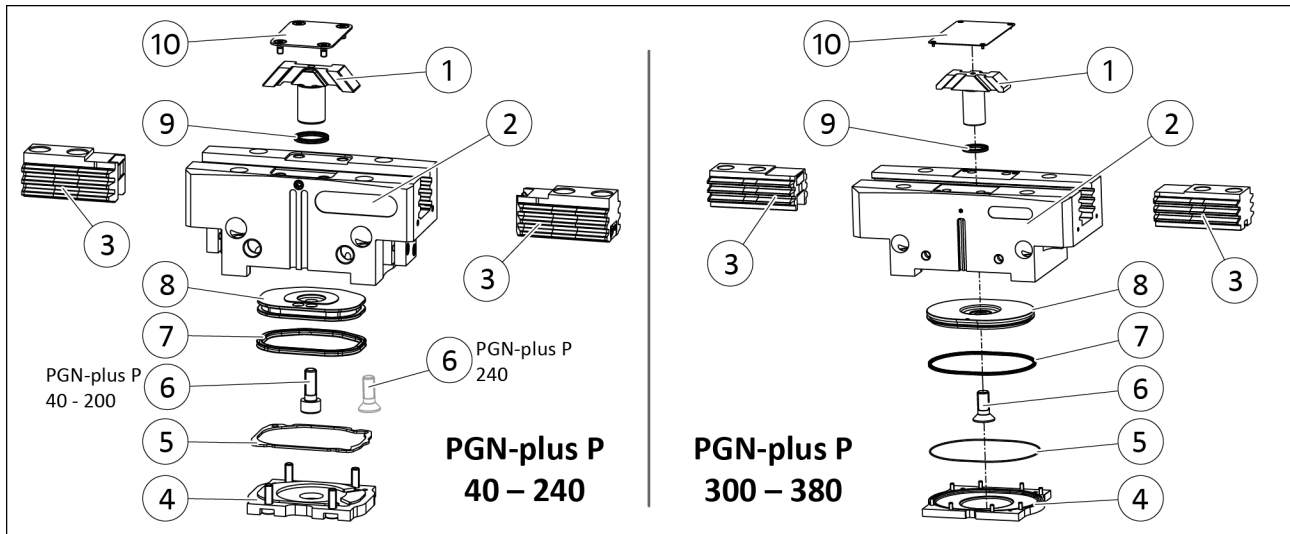

1. Remove all compressed air lines, [Pneumatic connection](#) [▶ 22].
2. Remove product from the system/machine.
3. **Variant Dust-tight (SD):** [Remove dust cover](#) [▶ 54].
4. Remove the cover (10).
5. Mark the installation position of the base jaws (3) on the housing (2).
6. Remove the screws and the cover (4).
7. Unscrew screw (6) and take cylinder piston (8) out of the housing (2).
8. Push the wedge hook (1) out of the housing (2).
9. Take base jaws (3) out of the housing (2).
10. Remove old seals (9, 5 and 7).
11. Clean guiding areas.
12. Mount new seals (9 and 7) from the seal kit.
13. Re-lubricating guiding areas
14. Insert base jaws (3) into the housing (2). **IMPORTANT! Observe installation position of the base jaws (3) in the housing (2).**
15. Insert wedge hook (1) into the housing (2).
16. Insert cylinder piston (8) into the housing (2) and while doing so, observe the installation position of the magnets, [Installation position of the magnets in the piston](#) [▶ 55].
17. Tighten screw (6). Secure the screw with medium-strength threadlocker.
Tightening torque: [Tightening torques](#) [▶ 56]
18. Insert flat gasket (5).

19. Fasten the cover (4) with the screws.
Tightening torque: [Tightening torques](#) [► 56]
20. **Variant Dust-tight (SD):** Reassemble dust cover in reverse order, [Remove dust cover](#) [► 54] .
21. Fasten the cover (10) with the screws.
22. Mount product onto the system/machine.
23. Connect all compressed air lines.

7.5.2 Replace seal (variant with gripping force maintenance "O.D. gripping")

NOTE

During assembly, the cylinder piston must be aligned precisely. We therefore recommend having SCHUNK change the seals.

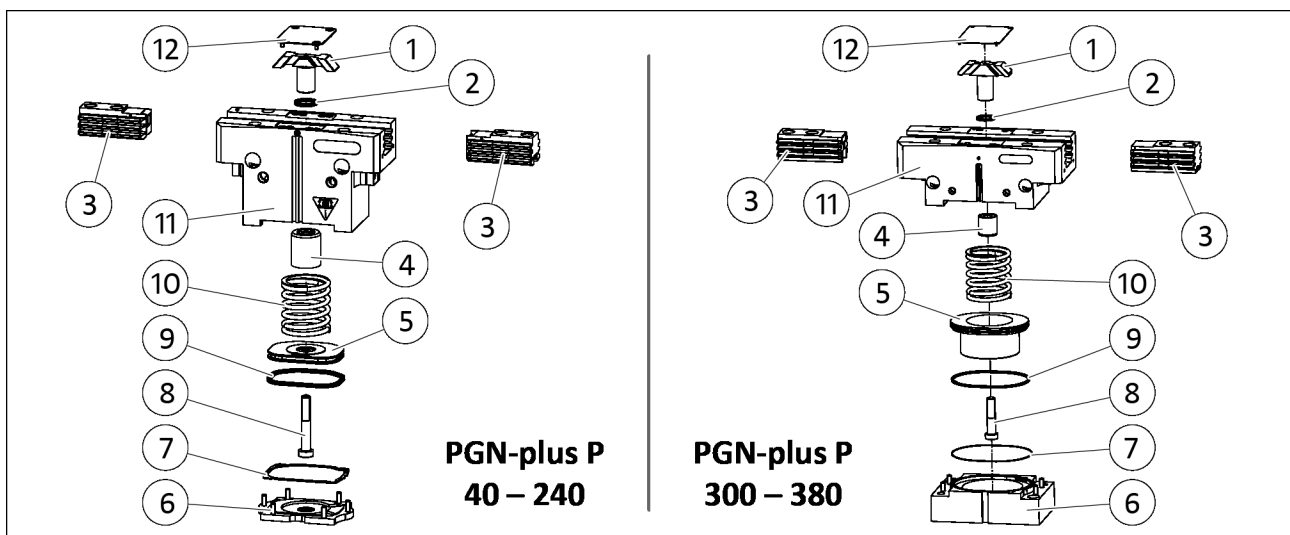

1. Remove all compressed air lines, [Pneumatic connection](#) [► 22].
2. Remove product from the system/machine.
3. **Variant Dust-tight (SD):** [Remove dust cover](#) [► 54].
4. Remove the cover (12).
5. Mark the installation position of the base jaws (3) on the housing (11).
6. Unscrew the screws and remove the cover (6).
7. **IMPORTANT! The cylinder piston is under spring tension. Remove carefully.**
Unscrew screw (8) carefully and take cylinder piston (5), spring (10) and the spacer (4) out of the housing (11).
8. Push the wedge hook (1) out of the housing (11).
9. Take base jaws (3) out of the housing (11).
10. Remove old seals (2, 7 and 9).
11. Clean guiding areas.
12. Attach new seals (2 and 9) from the seal kit.
13. Re-lubricating guiding areas

14. Insert base jaws (3) into the housing (11).
IMPORTANT! Observe installation position of the base jaws (3) in the housing (11).
15. Insert wedge hook (1) into the housing (11).
16. Insert spring (10) and spacer (4) into the housing (11).
17. Place the cylinder piston (5) in the housing (11) and while doing so, observe the installation position of the magnets, [Installation position of the magnets in the piston](#) [▶ 55].
18. Align the cylinder piston (5) exactly.
19. Tighten the screw (8) and secure with medium-strength threadlocker.
Tightening torque: [Tightening torques](#) [▶ 56]
20. Place cylinder piston (5) on the assembly device (13), slide towards the housing and tighten screw (8). Secure the screw with medium-strength threadlocker.
Tightening torque: [Tightening torques](#) [▶ 56]
21. Insert flat gasket (7).
22. Fasten the cover (6) with the screws.
Tightening torque: [Tightening torques](#) [▶ 56]
23. **Variant Dust-tight (SD):** Reassemble dust cover in reverse order, [Remove dust cover](#) [▶ 54] .
24. Fasten the cover (12) with the screws.
25. Mount product onto the system/machine.
26. Connect all compressed air lines.

7.5.3 Replace seal (variant with gripping force maintenance "I.D. gripping")

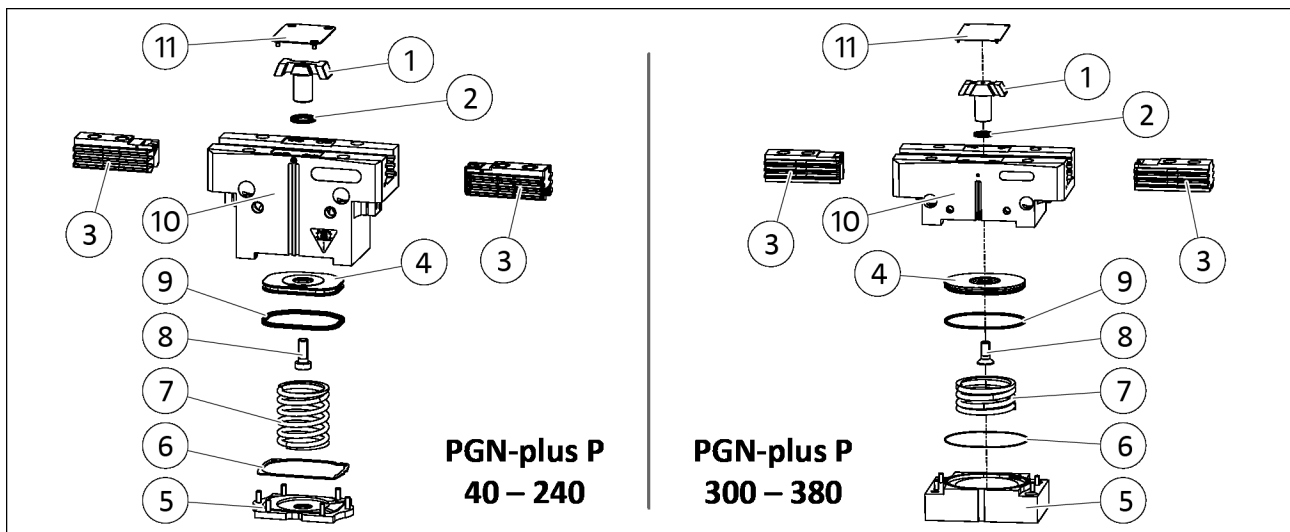

1. Remove all compressed air lines, [Pneumatic connection](#) [▶ 22].
2. Remove product from the system/machine.
3. **Variant Dust-tight (SD):** [Remove dust cover](#) [▶ 54].
4. Remove the cover (11).
5. Mark the installation position of the base jaws (3) on the housing (10).
6. **IMPORTANT! Cover (5) is under spring tension. Remove carefully.**
Carefully unscrew the screws and remove the cover (5) and the spring (7).
7. Unscrew screw (8) and take cylinder piston (4) out of the housing (10).
8. Push the wedge hook (1) out of the housing (10).
9. Take base jaws (3) out of the housing (10).
10. Remove old seals (2, 6 and 9).
11. Clean guiding areas.
12. Attach new seals (2 and 9) from the seal kit.
13. Re-lubricating guiding areas
14. Insert base jaws (3) into the housing (10). **IMPORTANT! Observe installation position of the base jaws (3) in the housing (10).**
15. Insert wedge hook (1) into the housing (10).
16. Insert the cylinder piston (4) into the housing (10) and while doing so, observe the installation position of the magnets, [Installation position of the magnets in the piston](#) [▶ 55].
17. Tighten screw (8). Secure the screw with medium-strength threadlocker.
Tightening torque: [Tightening torques](#) [▶ 56]
18. Insert spring (7) into the housing (10). In doing so, observe the alignment of the spring in relation to the cylinder piston.

19. Insert flat gasket (6).
20. Fasten the cover (5) with the screws.
Tightening torque: [Tightening torques](#) [▶ 56]
21. **Variant Dust-tight (SD)**: Reassemble dust cover in reverse order, [Remove dust cover](#) [▶ 54] .
22. Fasten the cover (11) with the screws.
23. Mount product onto the system/machine.
24. Connect all compressed air lines.

7.5.4 Remove dust cover

The dust cover is only included in the dust-tight version (SD).

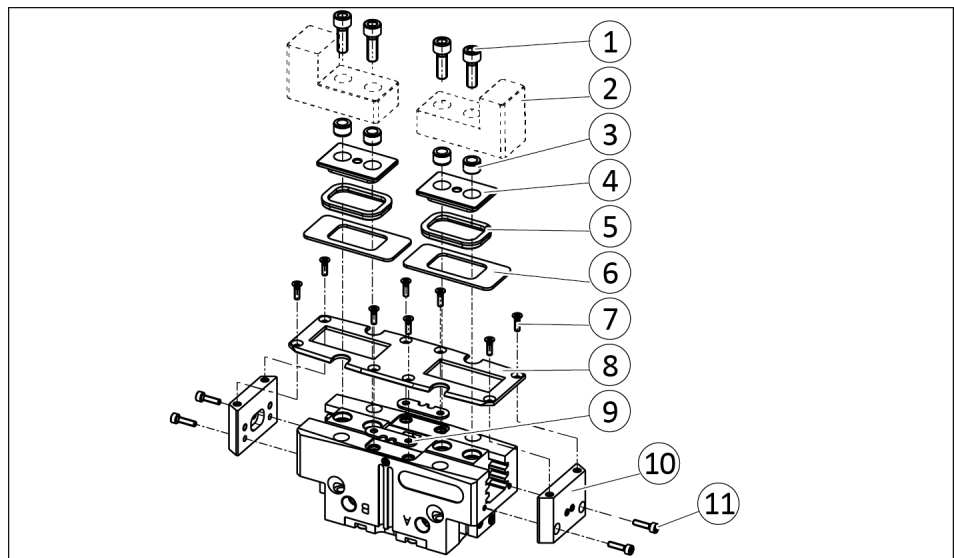

1. Unscrew the screws (1) and remove gripper finger (2) centering sleeves (3).
2. Pull the intermediate jaws (4) upwards and out and remove the seals (5) and shims (6).
3. Slacken the countersunk screws (7) and remove cover (8) and seals (9).
4. Unscrew the screws (11) and detach the covers (10).

7.6 Installation position of the magnets in the piston

The installation position of the piston in the housing depends on the size and variant. The magnets (1) attached to the piston can either point upwards (A) or downwards (B).

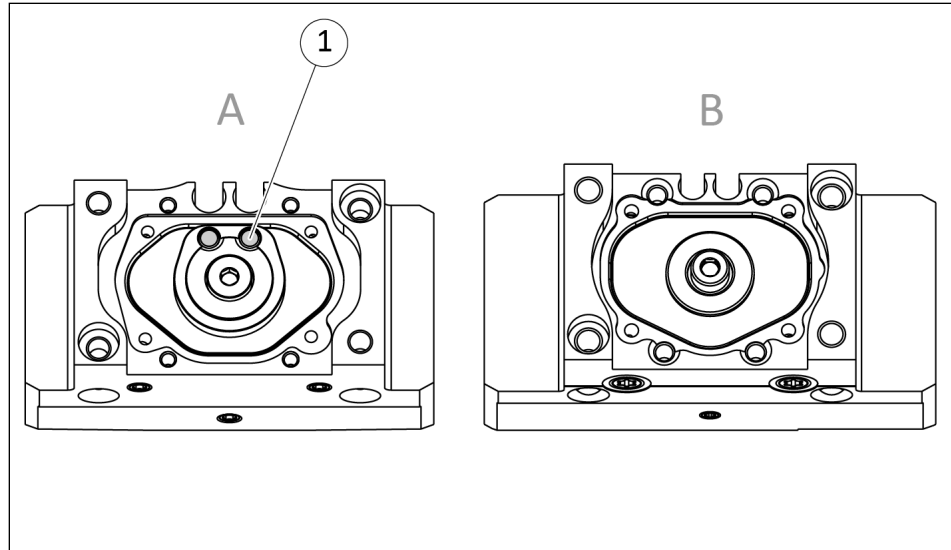

Installation position of the piston in the housing, A: Magnet (1) above, B: Magnet below

Size	A	B
Variant without maintenance of gripping force		
PGN-plus-P 40	X	-
PGN-plus-P 50 - 240	-	X
PGN-plus-P 300 - 380	-	X
Variant with "O.D. gripping" maintenance of gripping force		
PGN-plus-P 40 OD	X	-
PGN-plus-P 50-125 OD	-	X
PGN-plus-P 160-240 OD	X	-
PGN-plus-P 300 - 380 OD	-	X
Variant with "I.D. gripping" maintenance of gripping force		
PGN-plus-P 40 ID	X	-
PGN-plus-P 50 - 240 ID	-	X
PGN-plus-P 300 - 380 ID	-	X

7.7 Tightening torques

Position of the item numbers: [Assembly drawing](#) [▶ 57]

PGN-plus-P 40-240: Tightening torque for screws - details in Nm

Size	Item 40	Item 41
PGN-plus-P 40	1.2	0.27
PGN-plus-P 50	1.2	1.2
PGN-plus-P 64	6.1	1.2
PGN-plus-P 80	10	3.1
PGN-plus-P 100	15	3.1
PGN-plus-P 125	25	3.1
PGN-plus-P 160	49	2.2
PGN-plus-P 200	65.5	4.3
PGN-plus-P 240	85	4.3

PGN-plus-P 300-380 (without GKS): Tightening torque for screws - details in Nm

Size	Item 40	Item45	Item 41	Item 46
PGN-plus-P 300 -1/-2	120	–	6	–
PGN-plus-P 300 AS	–	150	–	25
PGN-plus-P 300 IS	120	–	–	25
PGN-plus-P 380 -1/-2	200	–	10	–
PGN-plus-P 380 AS	–	290	–	50
PGN-plus-P 380 IS	200	–	–	50

7.8 Assembly drawing

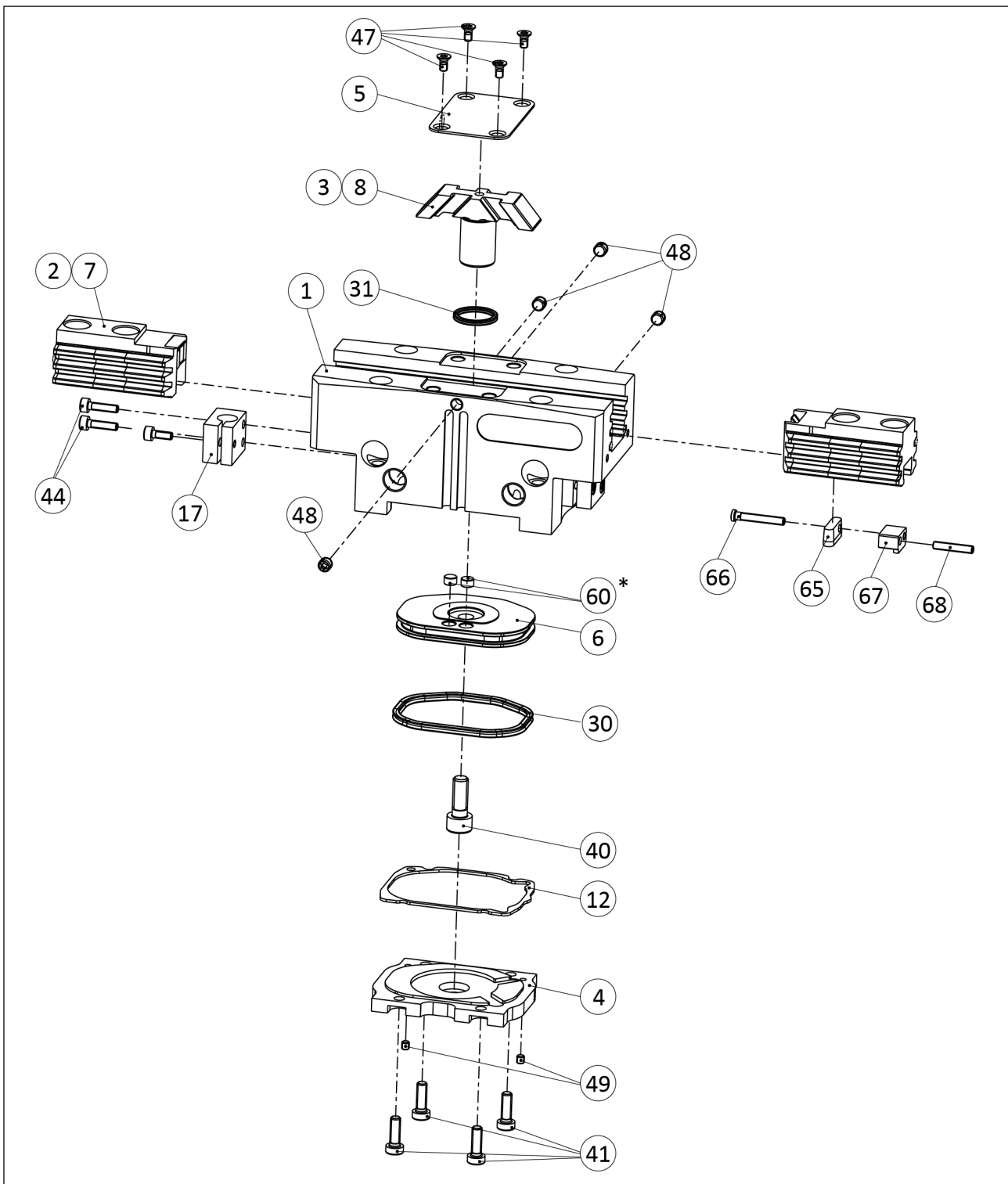

PGN-plus-P 40 – 200 standard

* Position of the magnets in the piston depends on the variant and size, [Installation position of the magnets in the piston](#) [► 55].

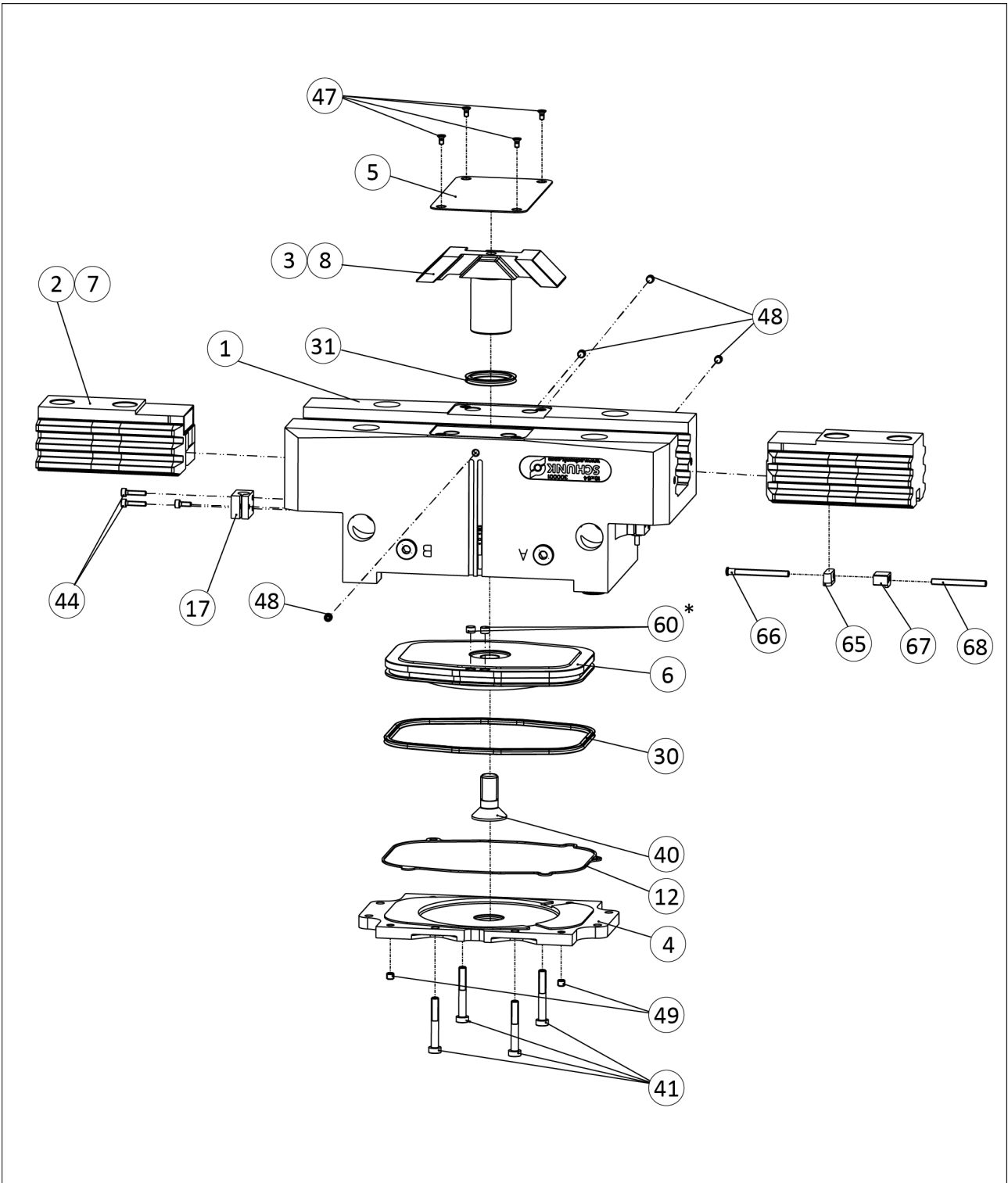

PGN-plus-P 240 standard

* Position of the magnets in the piston depends on the variant and size, [Installation position of the magnets in the piston](#) [► 55].

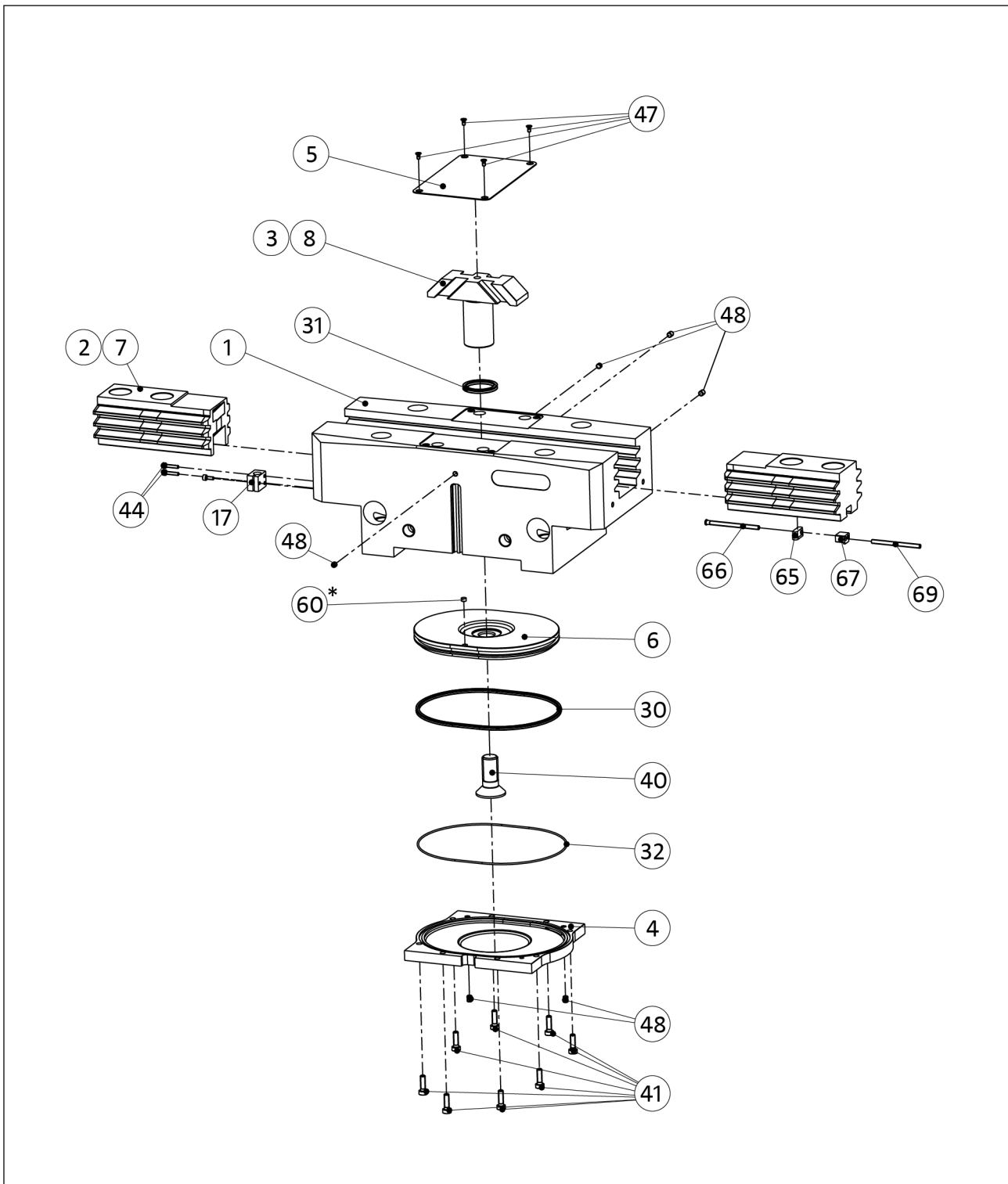

PGN-plus-P 300 – 380 standard

* Position of the magnets in the piston depends on the variant and size, [Installation position of the magnets in the piston](#) [► 55].

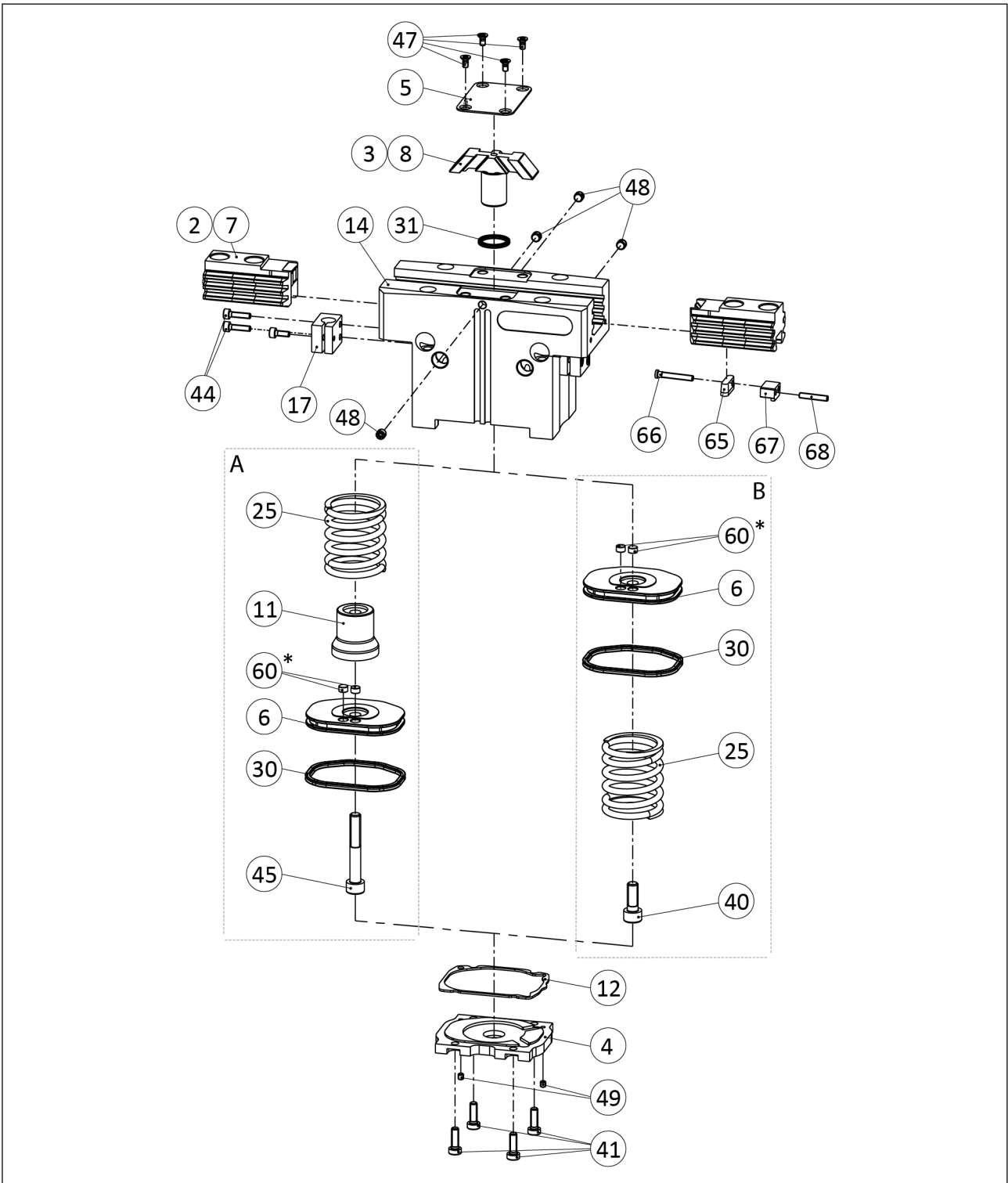

PGN-plus-P 40 – 240 with maintenance of gripping force O.D. gripping (A) and I.D. gripping (B)

* Position of the magnets in the piston depends on the variant and size, [Installation position of the magnets in the piston](#) [► 55].

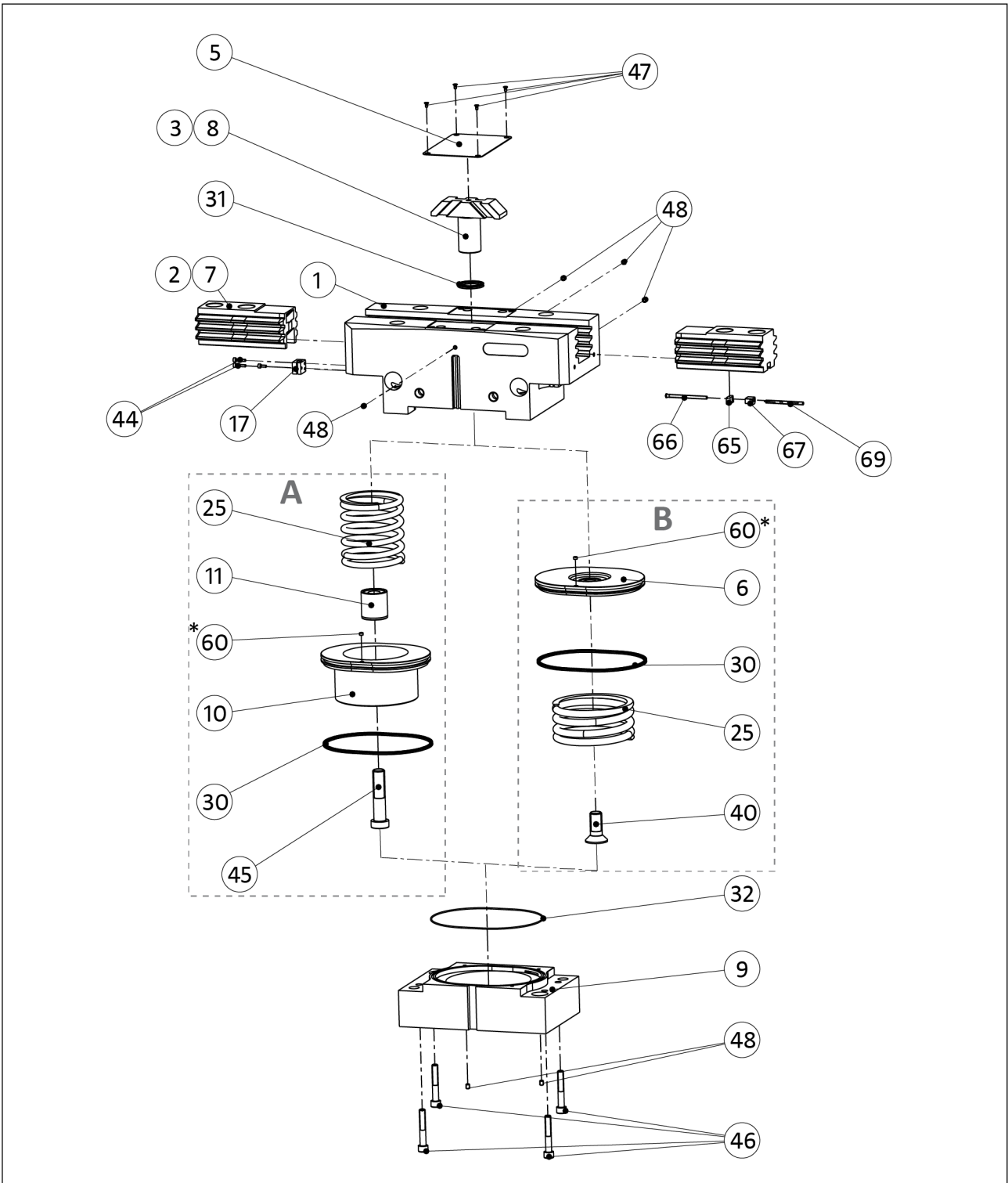

PGN-plus-P 300 – 380 with maintenance of gripping force O.D. gripping (A) and I.D. gripping (B)

* Position of the magnets in the piston depends on the variant and size, [Installation position of the magnets in the piston](#) [▶ 55].

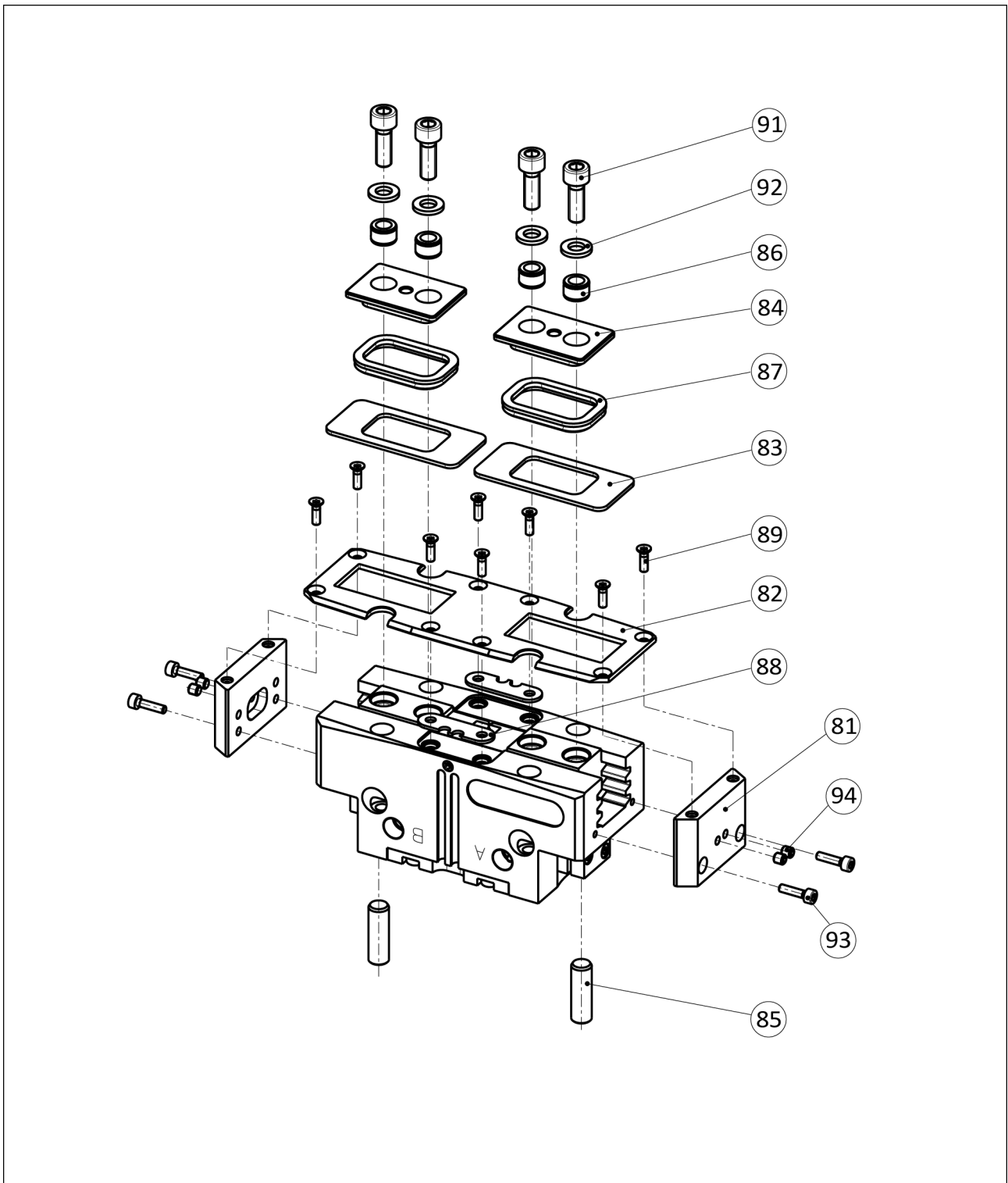

Variant dustproof (SD)

8 Translation of original declaration of incorporation

in terms of the Directive 2006/42/EG, Annex II, Part 1.B of the European Parliament and of the Council on machinery.

Manufacturer/
Distributor SCHUNK GmbH & Co. KG Clamping and gripping technology
Bahnhofstr. 106 - 134
D-74348 Lauffen/Neckar

We hereby declare that on the date of the declaration the following partly completed machine complied with all basic safety and health regulations found in the directive 2006/42/EC of the European Parliament and of the Council on machinery. The declaration is rendered invalid if modifications are made to the product.

Product designation: 2-Finger Parallel Gripper / PGN-plus-P / pneumatic
ID number 0318448 ... 39318573

The partly completed machine may not be put into operation until conformity of the machine into which the partly completed machine is to be installed with the provisions of the Machinery Directive (2006/42/EC) is confirmed.

Applied harmonized standards, especially:

EN ISO 12100:2010 Safety of machinery - General principles for design -
Risk assessment and risk reduction

The manufacturer agrees to forward on demand the relevant technical documentation for the partly completed machinery in electronic form to national authorities.

The relevant technical documentation according to Annex VII, Part B, belonging to the partly completed machinery, has been created.

Person authorized to compile the technical documentation:
Robert Leuthner, Address: see manufacturer's address

Signature: see original declaration

Lauffen/Neckar, January 2021

p.p. Ralf Winkler; Head of Technology
& Engineering, Mechanics Gripping
Systems

9 Annex to Declaration of Incorporation

according 2006/42/EG, Annex II, No. 1 B

1. Description of the essential health and safety requirements pursuant to 2006/42/EC, Annex I that are applicable and that have been fulfilled with:

Product designation	2-Finger Parallel Gripper
Type designation	PGN-plus-P
ID number	0318448 ... 39318573

To be provided by the System Integrator for the overall machine	↓
Fulfilled for the scope of the partly completed machine	↓
Not relevant	↓

1.1	Essential Requirements		
1.1.1	Definitions	X	
1.1.2	Principles of safety integration	X	
1.1.3	Materials and products	X	
1.1.4	Lighting	X	
1.1.5	Design of machinery to facilitate its handling	X	
1.1.6	Ergonomics	X	
1.1.7	Operating positions		X
1.1.8	Seating		X

1.2	Control Systems		
1.2.1	Safety and reliability of control systems	X	
1.2.2	Control devices	X	
1.2.3	Starting	X	
1.2.4	Stopping	X	
1.2.4.1	Normal stop	X	
1.2.4.2	Operational stop	X	
1.2.4.3	Emergency stop	X	
1.2.4.4	Assembly of machinery	X	
1.2.5	Selection of control or operating modes	X	
1.2.6	Failure of the power supply		X

1.3	Protection against mechanical hazards			
1.3.1	Risk of loss of stability			X
1.3.2	Risk of break-up during operation			X
1.3.3	Risks due to falling or ejected objects			X
1.3.4	Risks due to surfaces, edges or angles		X	
1.3.5	Risks related to combined machinery			X
1.3.6	Risks related to variations in operating conditions			X
1.3.7	Risks related to moving parts		X	
1.3.8	Choice of protection against risks arising from moving parts			X
1.3.8.1	Moving transmission parts		X	
1.3.8.2	Moving parts involved in the process			X
1.3.9	Risks of uncontrolled movements			X
1.4	Required characteristics of guards and protective devices			
1.4.1	General requirements			X
1.4.2	Special requirements for guards			X
1.4.2.1	Fixed guards			X
1.4.2.2	Interlocking movable guards			X
1.4.2.3	Adjustable guards restricting access			X
1.4.3	Special requirements for protective devices			X
1.5	Risks due to other hazards			
1.5.1	Electricity supply		X	
1.5.2	Static electricity		X	
1.5.3	Energy supply other than electricity		X	
1.5.4	Errors of fitting		X	
1.5.5	Extreme temperatures			X
1.5.6	Fire			X
1.5.7	Explosion			X
1.5.8	Noise			X
1.5.9	Vibrations			X
1.5.10	Radiation	X		
1.5.11	External radiation	X		
1.5.12	Laser radiation	X		
1.5.13	Emissions of hazardous materials and substances			X
1.5.14	Risk of being trapped in a machine	X		
1.5.15	Risk of slipping, tripping or falling	X		
1.5.16	Lightning			X

1.6	Maintenance			
1.6.1	Machinery maintenance		X	
1.6.2	Access to operating positions and servicing points		X	
1.6.3	Isolation of energy sources		X	
1.6.4	Operator intervention		X	
1.6.5	Cleaning of internal parts		X	
1.7	Information			
1.7.1	Information and warnings on the machinery		X	
1.7.1.1	Information and information devices		X	
1.7.1.2	Warning devices		X	
1.7.2	Warning of residual risks		X	
1.7.3	Marking of machinery	X		
1.7.4	Instructions	X		
1.7.4.1	General principles for the drafting of instructions	X		
1.7.4.2	Contents of the instructions	X		
1.7.4.3	Sales literature	X		
	The classification from Annex 1 is to be supplemented from here forward.			
2	Supplementary essential health and safety requirements for certain categories of machinery			X
2.1	Foodstuffs machinery and machinery for cosmetics or pharmaceutical products			X
2.2	Portable hand-held and/or guided machinery			X
2.2.1	Portable fixing and other impact machinery			X
2.3	Machinery for working wood and material with similar physical characteristics			X
3	Supplementary essential health and safety requirements to offset hazards due to the mobility of machinery		X	
4	Supplementary essential health and safety requirements to offset hazards due to lifting operations		X	
5	Supplementary essential health and safety requirements for machinery intended for underground work			X
6	Supplementary essential health and safety requirements for machinery presenting particular hazards due to the lifting of persons		X	



SCHUNK GmbH & Co. KG
Clamping and gripping technology

Bahnhofstr. 106 - 134
D-74348 Lauffen/Neckar
Tel. +49-7133-103-0
Fax +49-7133-103-2399
info@de.schunk.com
schunk.com

Folgen Sie uns | *Follow us*

