

# Manual chuck ROTA-S plus 2.0 with jaw lock Assembly and Operating Manual



## Imprint

### Copyright:

This manual is protected by copyright. The author is SCHUNK GmbH & Co. KG. All rights reserved. Any reproduction, processing, distribution (making available to third parties), translation or other usage - even excerpts - of the manual is especially prohibited and requires our written approval.

### Technical changes:

We reserve the right to make technical improvements.

**Document number:** 0889002

**Version:** 06.00 | 10/12/2020 | en-US

© H.-D. SCHUNK GmbH & Co.

All rights reserved

Dear Customer

Dear Customer,

Thank you for putting your trust in our products and our family-owned company, the leading technology supplier of robots and production machines.

Our team is always available to answer any questions on this product and other solutions. We look forward to your challenging questions. We will find a solution!

Best regards,

Your SCHUNK team

H.-D. SCHUNK GmbH & Co.

Spanntechnik KG

Lothringer Str. 23

D-88512 Mengen

Tel. +49-7572-7614-0

Fax +49-7572-7614-1099

info@de.schunk.com

schunk.com

Customer Management

Tel. +49-7572-7614-1300

Fax +49-7572-7614-1039

customercentermengen@de.schunk.com



**Please read the operating manual in full and keep it close to the product.**

## Table of Contents

<b>1</b>	<b>About this Manual</b> .....	<b>5</b>
1.1	Illustration of safety notes .....	5
1.2	Applicable documents .....	6
<b>2</b>	<b>Basic safety notes</b> .....	<b>7</b>
2.1	Appropriate use.....	7
2.2	Inappropriate use .....	7
2.3	Notes on particular risks.....	8
2.4	Notes on safe operation.....	10
2.4.1	Structural changes .....	14
2.5	Personnel qualification.....	14
2.6	Organizational measures.....	14
2.7	Personal protective equipment.....	15
<b>3</b>	<b>Warranty</b> .....	<b>16</b>
<b>4</b>	<b>Screw tightening torques</b> .....	<b>16</b>
<b>5</b>	<b>Scope of delivery</b> .....	<b>16</b>
<b>6</b>	<b>Technical data</b> .....	<b>17</b>
6.1	Chuck data .....	17
6.2	Clamping force RPM diagrams .....	18
6.3	Calculating the clamping force and RPM .....	22
6.3.1	Calculation of the required clamping force at a specified speed of rotation .....	22
6.3.2	Calculation example: required initial clamping force $F_{sp0}$ for a given RPM $n$ .....	24
6.3.3	Calculation of the permissible speed of rotation $n_{perm}$ in case of a given initial clamping force $F_{sp0}$ .....	25
6.4	Accuracy classes .....	26
6.5	Permitted imbalance .....	26
<b>7</b>	<b>Attachment of the manual lathe chuck</b> .....	<b>27</b>
7.1	Handling prior to attachment.....	27
7.2	Preparing the chuck attachment.....	27
7.3	Assembly of the manual lathe chuck .....	28
<b>8</b>	<b>Function</b> .....	<b>29</b>
8.1	Handling and jaw change .....	29
8.2	Important notes.....	31
8.3	Checking the chuck.....	32
8.4	True running check.....	33

<b>9</b>	<b>Maintenance</b> .....	<b>35</b>
9.1	Disassembling and assembling the chuck .....	35
9.2	Jaw change .....	37
9.3	At least once a month .....	37
9.4	In the case of decreasing clamping force or after about 200 operating hours .....	38
9.5	Maintenance intervals.....	38
<b>10</b>	<b>Disposal</b> .....	<b>39</b>
<b>11</b>	<b>Spare parts</b> .....	<b>40</b>
<b>12</b>	<b>Assembly drawing</b> .....	<b>41</b>

## 1 About this Manual

This manual contains important information for the safe, correct use of the product.

The manual is an integral part of the product and must be kept accessible by personnel at all times.





Personnel must have read and understood this manual before beginning any work. The observance of all safety notes in this manual is the precondition for all safe working.

The illustrations in this manual are intended to provide a basic understanding and may deviate from the actual version.

Besides this manual, other documents which apply are those listed under [\(☞ 1.2, Page 6\)](#).

### 1.1 Illustration of safety notes

To make risks clear, the following signal words and symbols are used for safety notes.

	<p><b>⚠ DANGER</b></p> <p><b>Danger to individuals!</b> Ignoring a safety note such as this will certainly lead to irreversible injury and even death.</p>
	<p><b>⚠ WARNING</b></p> <p><b>Danger to individuals!</b> Ignoring a safety note such as this can lead to irreversible injury and even death.</p>
	<p><b>⚠ CAUTION</b></p> <p><b>Danger to individuals!</b> Non-observance can cause minor injuries.</p>
	<p><b>NOTICE</b></p> <p><b>Material damage!</b> Information about avoiding material damage.</p>

## 1.2 Applicable documents

- General terms and conditions \*
- Catalog data sheet for purchased product \*
- Calculation of the jaw centrifugal forces, in the chapter "Technology" of the lathe chuck catalog \*

The documents indicated with an asterisk (\*) can be downloaded from **schunk.com**.

## 2 Basic safety notes

Improper handling, assembly and maintenance of this product may result in risk to persons and equipment if this operating manual is not observed.

Report any failures and damage immediately and repair without delay to keep the extent of the damage to a minimum and prevent compromising the safety of the product.

**Only original SCHUNK spare parts may be used.**

### 2.1 Appropriate use

This product is intended for clamping workpieces on lathes and other suitable machine tools.

- The product may only be used within the scope of its technical data, ([☞ 6, Page 17](#)).
- The product is intended for industrial and industry-oriented use.
- Appropriate use of the product includes compliance with all instructions in this manual.
- The maximum speed and the necessary clamping force must be determined by the operator for each clamping task in accordance with the valid standards or technical specifications of the manufacturer.  
(Also see "Calculation for clamping force and speed of rotation" in chapter "Technical data".) ([☞ 6, Page 17](#))

### 2.2 Inappropriate use

The product is not being used as intended if, for example:

- it is used as a press, a punch, a toolholder, a load-handling device or as lifting equipment.
- the product is used with machines/systems or workpieces that are not designed to be used with it.
- the specified technical data for use of the product are exceeded. ([☞ 6, Page 17](#))
- workpieces are not properly clamped, paying particular attention to the specified clamping forces.
- the product is used in working environments that are not permissible.
- the product is operated without protective equipment.

### 2.3 Notes on particular risks

This product may pose a danger to persons and property if, for example:

- it is not used as intended;
- it is not installed or maintained properly;
- the safety and installation instructions, local applicable safety and accident prevention regulations or the EC Machinery Directive are not observed.

	<b>! DANGER</b>
	<p><b>Possible risk of fatal injury to operating personnel if a jaw breaks or if the chuck fails because the technical data have been exceeded and a workpiece is released or parts fly off!</b></p> <ul style="list-style-type: none"><li>• The technical data specified by the manufacturer for using the lathe chuck must never be exceeded.</li><li>• The lathe chuck may only be used on machines and facilities that fulfill the minimum requirements of the EC Machinery Directive; specifically, they must have effective technical measures to protect against possible mechanical hazards.</li></ul>

	<b>! DANGER</b>
	<p><b>Risk of fatal injury to operating personnel from clothing or hair being caught on the lathe chuck and being dragged into the machine!</b></p> <p>Loose clothing or long hair may become caught on projecting parts of the lathe chuck and be drawn into the machine.</p> <ul style="list-style-type: none"><li>• The machines and equipment must fulfill the minimum requirements of the EC Machinery Directive; specifically, they must have effective technical measures to protect against potential mechanical hazards.</li><li>• Always wear tight-fitting clothing and a hairnet when working on the machine and the lathe chuck.</li></ul>



**⚠ WARNING**

**Risk of injury due to dropping the chuck during transport, installation or removal.**

- Take special care in the danger zone when transporting, installing or removing the lathe chuck.
- Note the relevant load securing regulations for working safely with cranes, ground conveyors, lifting gear and load-handling equipment.

**⚠ CAUTION**

**Risk of slipping or falling if the chuck's operational environment is not clean (e.g. contaminated with cooling lubricants or oil).**

- Ensure that the working environment is clean before starting assembly and installation work.
- Wear suitable safety boots.
- Follow the safety and accident prevention regulations when operating the chuck, especially when working with machine tools and other technical equipment.

**⚠ CAUTION**

**Risk of limbs being crushed when opening and closing the chuck jaws during manual loading or unloading or when exchanging moving parts.**

- Do not reach between the chuck jaws.
- Wear protective gloves.
- Follow the safety and accident prevention regulations when operating the chuck, especially when working with machine tools and other technical equipment.

**⚠ CAUTION**

**Risk of burns due to workpieces with high temperatures!**

- Wear protective gloves when removing the workpieces.
- Automatic loading is preferred.

	<b>⚠ CAUTION</b>
	<p><b>Risk of damage due to incorrect choice of clamping position for chuck jaws on workpiece.</b></p> <p>If an incorrect clamping position is chosen for the chuck jaws on workpiece, the base and top jaws may break.</p> <ul style="list-style-type: none"> <li>• Make sure that the workpiece is clamped concentrically.</li> <li>• If the chuck has a quick-change jaw system, the top jaws must not protrude beyond the base jaws in the radial direction.</li> </ul> <p><b>Exception:</b> The supporting jaw variant 3 protrudes beyond the chuck base jaw due to its design. In this case, the T-nuts always need to be completely inserted into the groove of the chuck base jaw.</p>

	<b>⚠ CAUTION</b>
	<p><b>Hazard from vibration due to imbalanced rotating parts and noise generation.</b></p> <p>Physical and mental strains due to imbalanced workpieces and noise during the machining process on the clamped and rotating workpiece.</p> <ul style="list-style-type: none"> <li>• Ensure the chuck's axial and concentric runout.</li> <li>• Check options for remedying imbalances on special top jaws and workpieces.</li> <li>• Reduce the RPM.</li> <li>• Wear hearing protection.</li> </ul>

## 2.4 Notes on safe operation



- Do not start the machine spindle until the workpiece is clamped and the spanner wrench has been removed from the chuck.
- Only operate the lathe chuck when all protective equipment has been fitted and is in full working order.
- Check the lathe chuck at least once per shift for externally visible damage and faults.



### Functional test

After installation of the lathe chuck, its function must be checked prior to start-up:

- **Clamping force!** At max. torque, the maximum clamping force specified for the lathe chuck must be reached.
- **Indicator pin!** Never clamp or switch on the lathe when the indicator pin is protruding. (Golden pin on the chuck's shell).
- **Jaw lock!** The spindle can only be turned when all the chuck jaws have been fitted into the T-slot. This prevents the wedge bars from being brought into the working position without chuck jaws.

### Speed of rotation

	 <b>DANGER</b>
	<p><b>Possible risk of fatal injury to operating personnel if the chuck's top speed is exceeded and a workpiece is released or parts fly off.</b></p> <p>If the machine tool or technical equipment can reach a higher speed than the chuck's top speed, a reliable speed limiter must be installed and proof must be provided that the speed limiter is effective.</p>

	 <b>WARNING</b>
	<p><b>Vibrations caused by machining can lead to a loss of clamping force. Risk of injury due to loss of workpiece.</b></p> <p>Manually actuated lathe chucks can lose clamping force due to the vibration caused by machining the workpiece.</p> <ul style="list-style-type: none"> <li>• Regularly adjust the lathe chuck during machining to compensate for loss of clamping force caused by vibrations.</li> </ul>

### Maintenance instructions

The reliability and safety of the manual lathe chuck can only be guaranteed if the operator complies with the maintenance instructions from the manufacturer.

- For lubrication, we recommend our tried and tested special grease, LINOMAX plus. Unsuitable lubricants can have a negative impact on the functioning of the lathe chuck (clamping force, coefficient of friction, wear characteristics).  
(For product information about LINOMAX plus, see the "Accessories" chapter of the SCHUNK lathe chuck catalog or contact SCHUNK.)

- Use a suitable high-pressure grease gun to ensure that you reach all the greasing areas.
- To ensure correct distribution of the grease, move the lathe chuck to its end positions several times, lubricate again, and then check the clamping force.
- We recommend checking the clamping force using a gripping force tester before starting a new production run and between maintenance intervals. \*Optimum safety can only be guaranteed through regular checks\*.
- The clamping force should always be measured in the state of the lathe chuck as used for the current clamping situation. If top jaws with clamping steps are used, measuring must be performed in the same step as for the respective clamping task. In the event of high operating speeds, clamping force losses must be accounted for due to the centrifugal force acting on the chuck jaws. In this case the value of the operating clamping force should be measured dynamically.
- Move the lathe chuck through to its end position several times after 500 clamping strokes, at the latest. (This moves the lubricant back to the surfaces of the force transmission, so that the clamping force is retained for longer).

### **Safety notes for servicing**

Follow all the applicable legal standards for health and safety during servicing. Use suitable personal protective equipment, especially protective gloves, goggles, and safety boots - paying particular attention to the operating system and hazard assessment.

Immediately report any changes including changed operational behavior to the competent units/persons; if necessary, immediately shut down and secure the machine on which the lathe chuck is mounted. Do not start up the machine that the chuck is mounted on again until the malfunction has been eliminated.

**! DANGER**

**Possible risk of fatal injury to operating personnel due to toolholder failure if the maintenance and servicing instructions for the toolholder are disregarded.**

The servicing instructions specified by the manufacturer must be complied with to ensure safe operation of the lathe chuck.

Work must be carried out by qualified specialist personnel with the relevant safety training.

**Use of special chuck jaws**

When using customized jaws, please observe the following rules:

- The chuck jaws should be designed to be as light and as low as possible. The clamping point must be as close as possible to the chuck face (clamping points at a greater distance lead to greater surface pressure in the jaw guidance and can significantly reduce the clamping force).
- Do not use welded jaws.
- If for constructional reasons the special chuck jaws are heavier than the top jaws assigned to the clamping device, greater centrifugal forces must be accounted for when defining the required clamping force and the recommended speed.
- Screw the jaw mounting bolts into the bore holes furthest apart.
- The maximum recommended speed may only be applied in conjunction with the maximum clamping force and only with the lathe chuck in optimum, fully functioning condition.
- If the lathe chuck is involved in a collision, it must be subjected to a crack test before using it again. Damaged parts must be replaced with original SCHUNK spare parts.
- Renew the chuck jaw mounting bolts if there are signs of wear or damage. Only use bolts with a quality of 12.9.

### 2.4.1 Structural changes

#### Implementation of structural changes

Modifications, changes or reworking, e. g. additional threads, holes, or safety devices, can damage the product or impair its functionality or safety.

- Structural changes should only be made with the written approval of SCHUNK.

### 2.5 Personnel qualification

The lathe chuck must only be installed, removed, started up, operated and serviced by qualified specialist personnel with the relevant safety training.

All persons charged with operating, maintaining and servicing this lathe chuck must have access to the operating manual, especially the chapter "Basic safety instructions". We recommend that the operator draw up in-house safety operating instructions.

Trainees may work on machines and technical equipment in which a lathe chuck is installed provided that they are supervised at all times by qualified specialist personnel.

### 2.6 Organizational measures

#### Obeying the rules

Via suitable organizational measures and instructions, the operator must ensure that the relevant safety rules are obeyed by the persons asked to operate, maintain and repair the lathe chuck.

#### Monitoring the behavior of personnel

The operator must at least occasionally check that the personnel are behaving in a safety-conscious manner and are aware of the potential hazards.

#### Danger signs

The operator must ensure that the signs concerning safety and hazards mounted on the machine where the lathe chuck is mounted are clearly legible and are observed.

**Faults**

If a fault occurs on the lathe chuck and this fault endangers safety or if a problem is suspected due to production characteristics, the machine tool where the lathe chuck is mounted must be immediately stopped and remain shut down until the fault has been located and remedied. Only allow specialists to remedy malfunctions.

**Spare parts**

Only ever use original SCHUNK spare parts.

**Environmental regulations**

Comply with the applicable legal norms when disposing of waste.

## 2.7 Personal protective equipment

**Use of personal protective equipment**

Personal protective equipment serves to protect staff in the event of a danger that may interfere with their health or safety at work.

- When working on and with the product, observe the occupational health and safety regulations and wear the required personal protective equipment.
- Observe the valid safety and accident prevention regulations.
- Wear protective gloves to guard against sharp edges and corners or rough surfaces.
- Wear heat-resistant protective gloves when handling hot surfaces.
- Wear protective gloves and safety goggles when handling hazardous substances.
- Wear close-fitting protective clothing and also wear long hair in a hairnet when dealing with moving components.

### 3 Warranty

If the product is used as intended, the warranty is valid for 60 months from the date of delivery from the production facility or 50 000 cycles\* under the following conditions:

- Refer to the applicable documents, ([👉 1.2, Page 6](#))
- Observance of the ambient conditions and operating conditions.
- Observance of the specified maintenance and lubrication intervals ([👉 9, Page 35](#))

Parts touching the workpiece and wearing parts are not part of the warranty.

\* One cycle comprises one complete clamping procedure ("opening" and "closing").

### 4 Screw tightening torques

**Tightening torques for mounting screws for clamping the chuck**  
(screw quality 10.9)

Screw size	M6	M8	M10	M12	M14	M16	M18	M20	M22	M24	M27	M30
Tightening torques M <sub>A</sub> (Nm)	13	28	50	88	120	160	200	290	400	500	1050	1500

**Tightening torques to mount top jaws onto the chuck** (screw quality 12.9)

Screws for base jaws SFG / SFGK / SFK-V / SFGL / SFGX	M6	M8 x 1 fine thread	M10	M12 x 1.5 fine thread	-	M16 x 1.5 fine thread	M20	-	M24
maximum admissible torque in (Nm)	16	30	60	85	-	105	180	-	230

### 5 Scope of delivery

#### 1 Manual lathe chuck (complete)

either with cylindrical recess and fixing screws

or with corresponding flange and accessories for machine spindle according to

- DIN ISO 702-1 Short-taper mount with screws from the front
- DIN ISO 702-2 Short-taper mount with camlock mounting
- DIN ISO 702-3 Short-taper mount with bayonet mounting

#### 1 Spanner wrench

#### 1 Operating manual



## 6 Technical data

### 6.1 Chuck data

ROTA-S plus 2.0	3-jaw chuck				2-jaw chuck			
	160-42	200-52	250-62	315-92	160-42	200-52	250-62	315-92
Max. torque [Nm]	80	120	210	220	55	80	140	150
Stroke per jaw [mm]	6.5	7.0	7.7	9.9	6.5	7	7.7	9.9
Recommended speed [RPM]	5400	4800	4200	3400	5400	4800	4200	3400
Max. jaw clamping force [kN]	65	100	160	180	40	65	105	120
Mass moment of inertia [kg m <sup>2</sup> ]	0.029	0.091	0.249	0.758	0.033	0.1	0.276	0.8196
Chuck bore [mm]	42	52	62	92	42	52	62	92
Weight without jaws [kg]	7.94	16.1	28.8	54.2	8.5	18.2	30.4	60.5
Centrifugal force of the base jaw with fine serration $M_{cGB}$ [kgm]	For the ROTA-S plus 2.0 chuck, it is necessary to specifically determine this data. Examples of calculation can be found in the "Chuck jaws in special design/technology" chapter in our current chuck jaw catalog.							
Max. jaw eccentricity of center of gravity in axial direction $a_{max}$ [mm]								

The maximum RPM stated is only valid with the maximum clamping force and when using the hard standard stepped jaws that go with the chuck.

For soft top jaws or jaws in special design jaws the speed permitted for the cutting task must be calculated in accordance with VDI 3106 whereby the max. recommended speed may not be exceeded. The calculated values must be checked by dynamic measurement. Functional monitoring must be performed according to the guidelines of the insurance association.

**The recommended speed is valid for ROTA-S plus 2.0 with SCHUNK stepped block jaws, hard, type STF.**

For this, the base jaws are inserted flush with outer diameter of the chuck.

	3-jaw chuck				2-jaw chuck			
Jaw type	STF 160	STF 200	STF 250	STF 315	STF 160	STF 200	STF 250	STF 315
Weight/set	1.1 kg	1.9 kg	3.3 kg	5.3 kg	0.73 kg	1.27 kg	2.2 kg	3.5 kg

The speed of rotation must be reduced for jaws with a higher weight!

**Max. oscillating circle - With type SFG base jaws**

ROTA-S plus 2.0	160-42	200-52	250-62	315-92
Oscillating circle $\varnothing$	208.5	264	323	401.5

At the rated speed the chucks are balanced to Q 6.3

Warranty and maximum clamping cycles

Length of warranty	60 months
Maximum clamping cycle number	50,000 cycles

**6.2 Clamping force RPM diagrams**

Clamping force/RPM curves have been determined by using hard jaws. In the determination process, the maximum actuating force was applied and the jaws were set flush with the outer diameter of the chuck.

The chuck is in perfect condition and lubricated with SCHUNK LINOMAX plus special grease.

Should one or several of above-mentioned parameters be changed, the diagrams will no longer be valid.

**Chuck setup for clamping force/RPM graph**

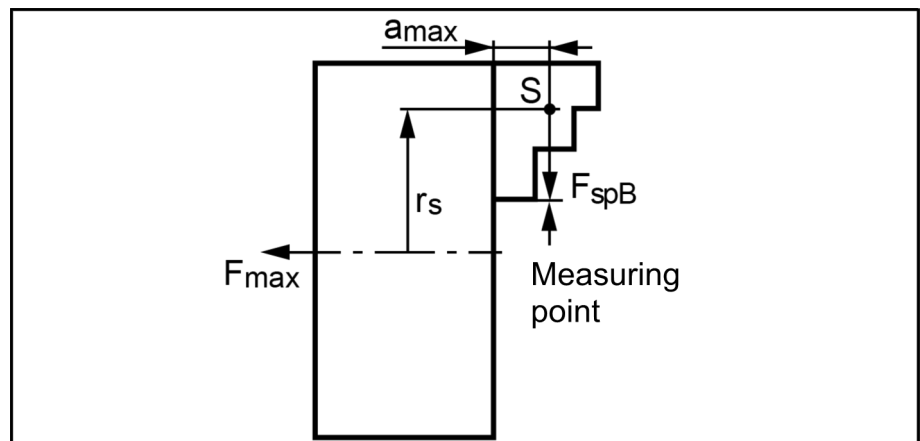

$F_{spB}$	Jaw clamping force	S	Center of gravity
$F_s$	Center of gravity radius	$a_{max}$	Max. jaw eccentricity of center of gravity in axial direction
$F_{max}$	Max. actuating force		

**Clamping force RPM diagram ROTA-S plus 2.0 160-42 - 3 jaws**

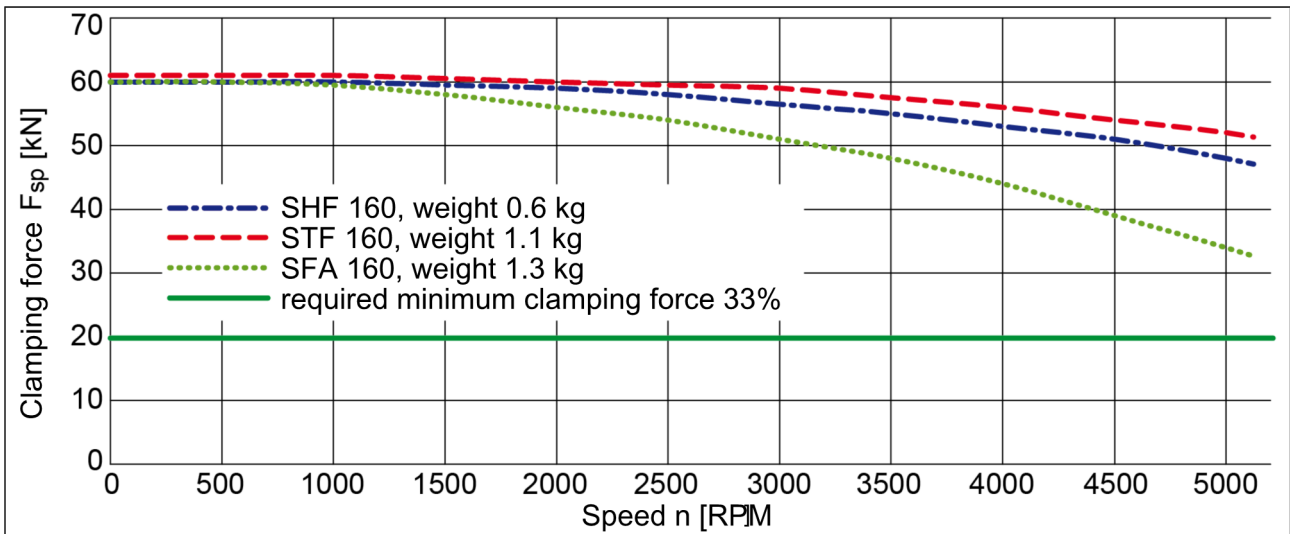

**Clamping force RPM diagram, ROTA-S plus 2.0 200-62 - 3 jaws**

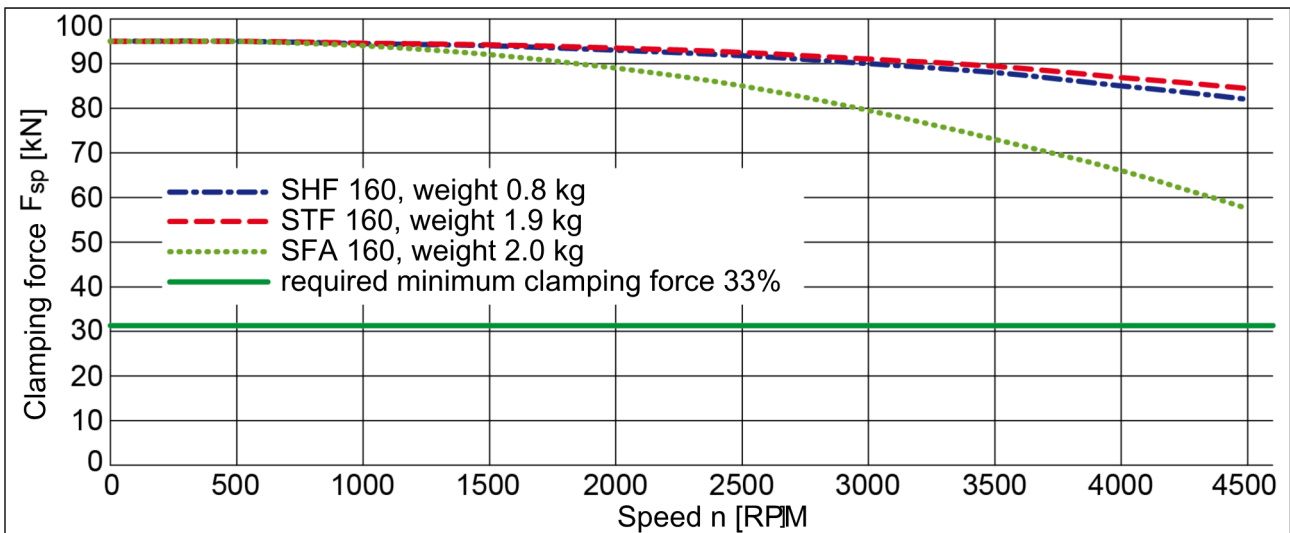

**Clamping force RPM diagram ROTA-S plus 2.0 250-52 - 3 jaws**

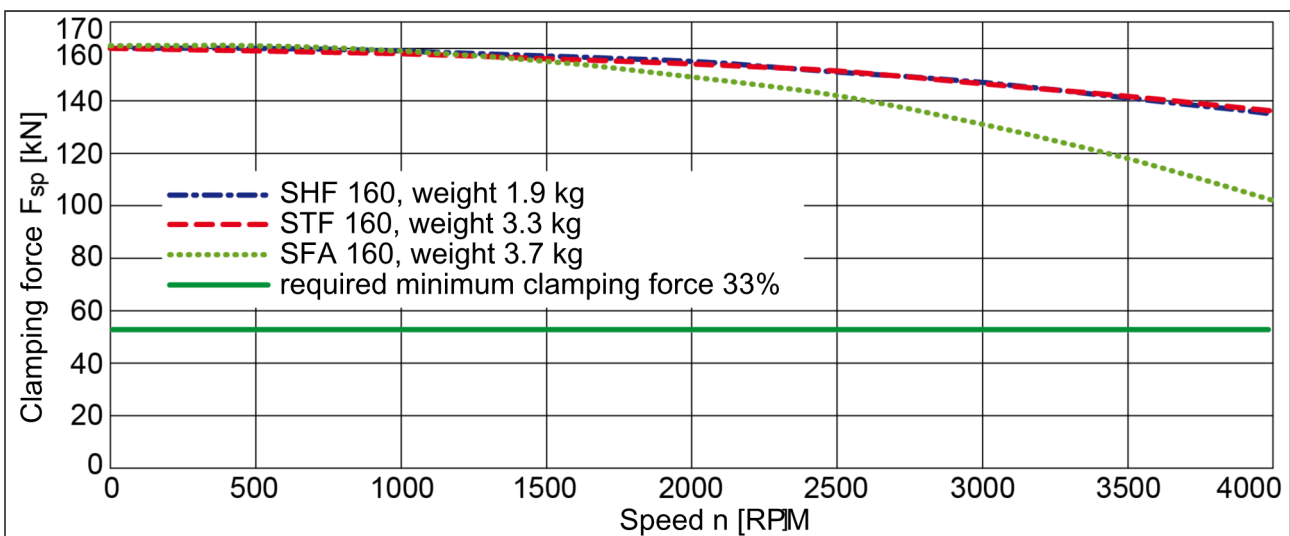

**Clamping force RPM diagram, ROTA-S plus 2.0 315-92 - 3 jaws**

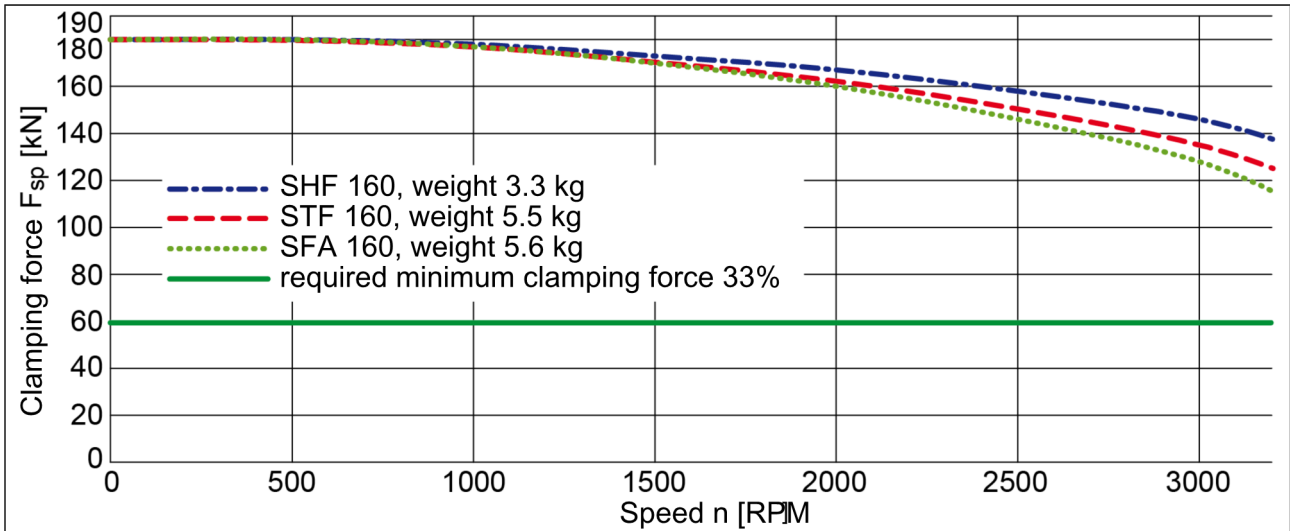

**Clamping force RPM diagram ROTA-S plus 2.0 160-42 - 2 jaws**

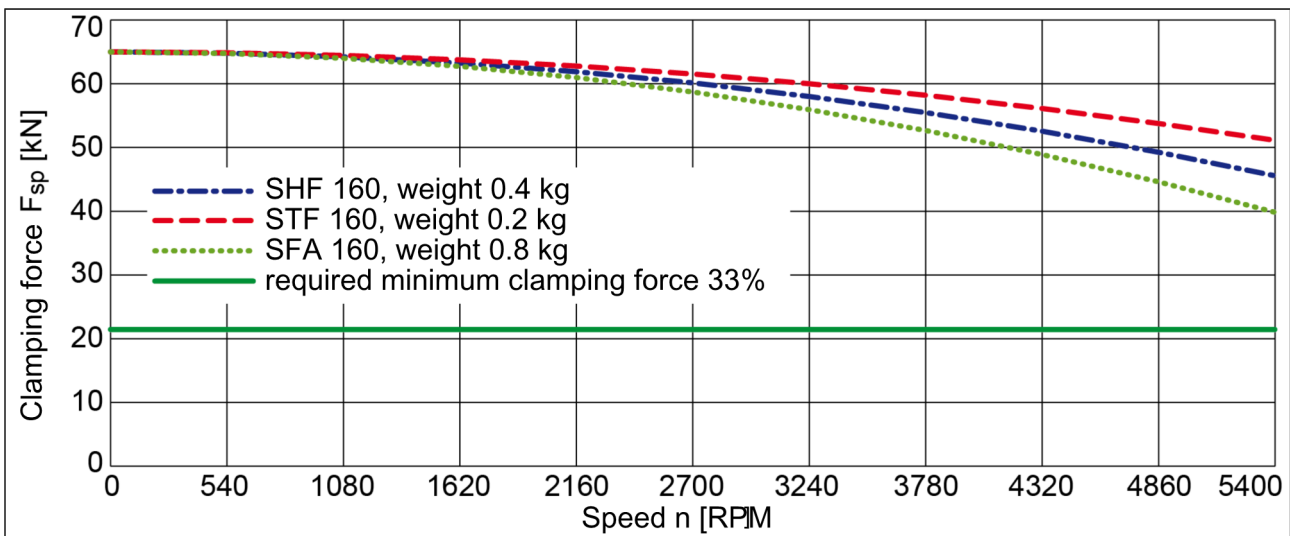

**Clamping force RPM diagram, ROTA-S plus 2.0 200-62 - 2 jaws**

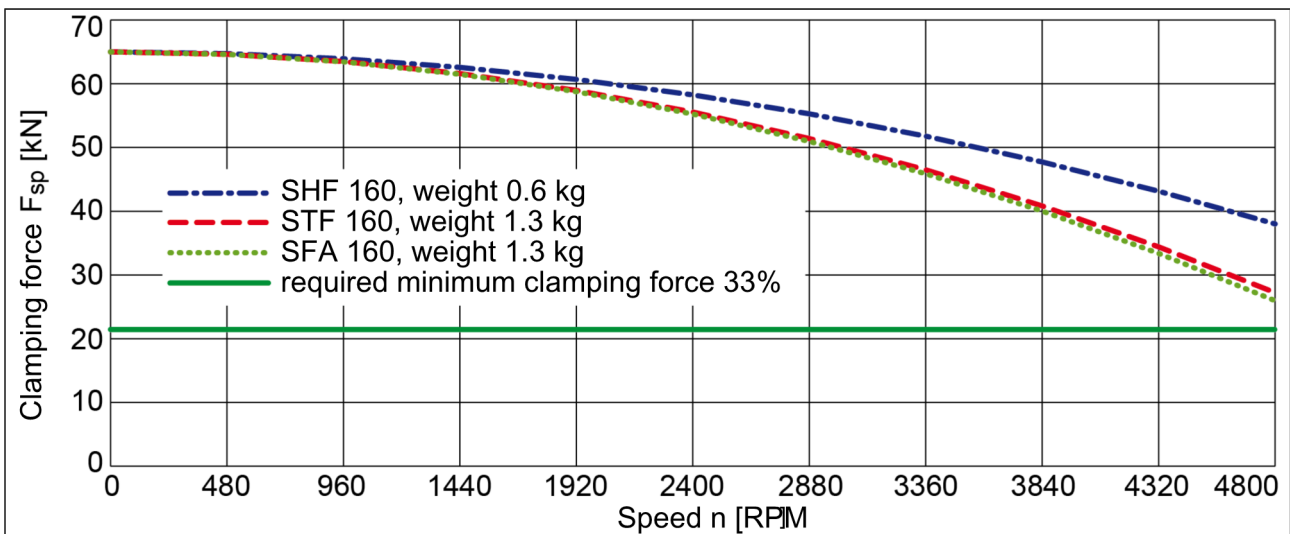

**Clamping force RPM diagram ROTA-S plus 2.0 250-52 - 2 jaws**

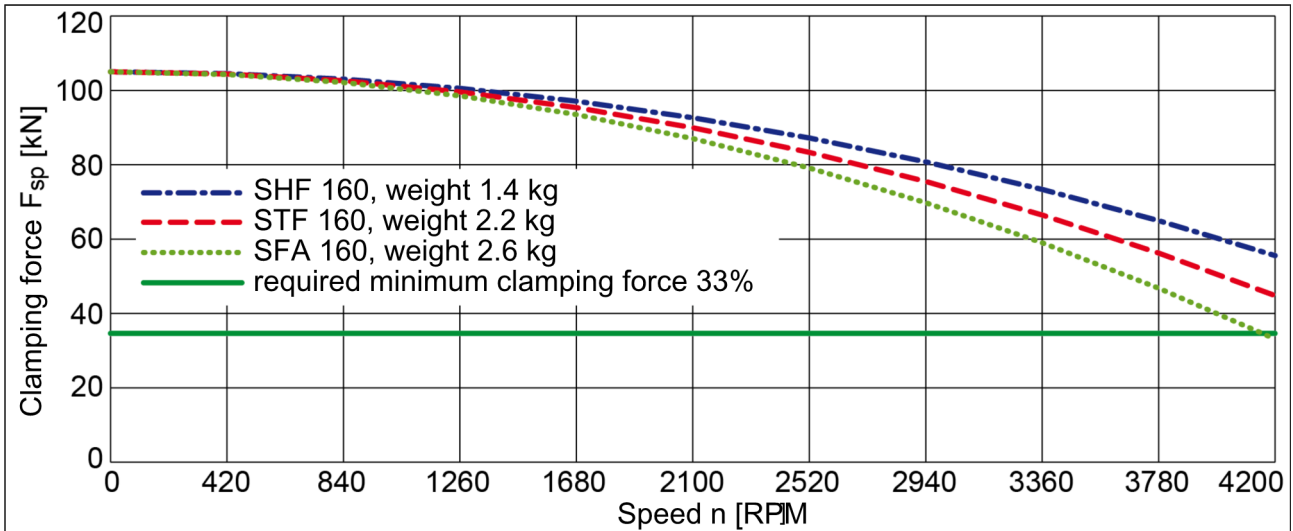

**Clamping force RPM diagram, ROTA-S plus 2.0 315-92 - 2 jaws**

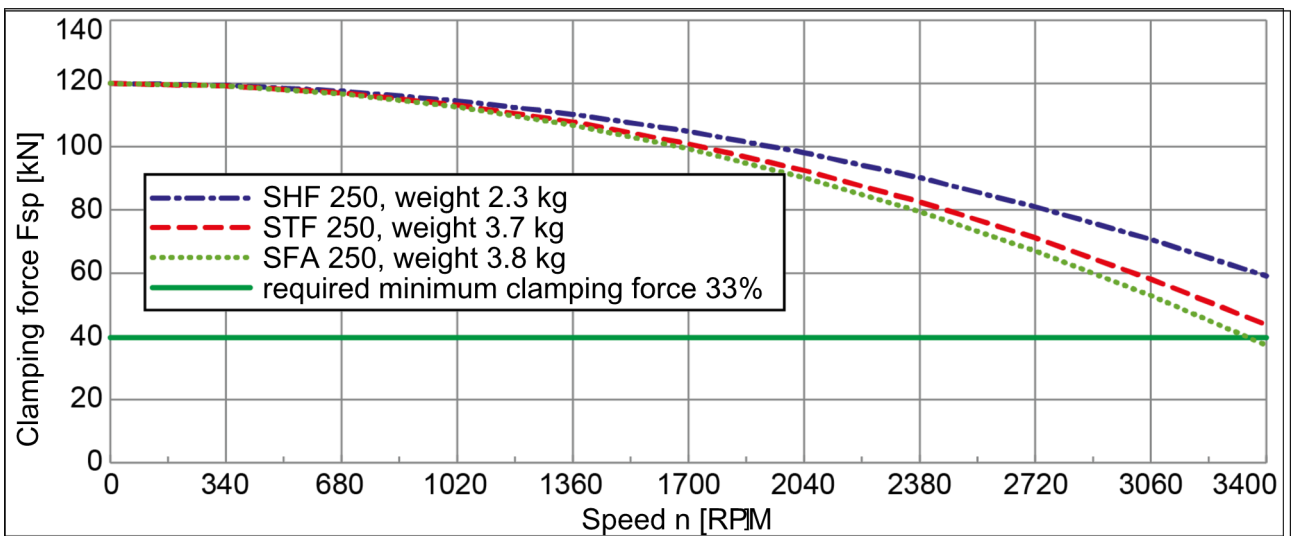

### 6.3 Calculating the clamping force and RPM

Missing information or specifications can be requested from the manufacturer.

Legend			
$F_c$	Total centrifugal force [N]	$M_{cAB}$	Centrifugal torque of top jaws [kgm]
$F_{sp}$	Effective clamping force [N]	$M_{cGB}$	Centrifugal torque of base jaws [kgm]
$F_{spmin}$	Minimum required clamping force [N]	$n$	Speed of rotation [RPM]
$F_{sp0}$	Initial clamping force [N]	$r_s$	Center of gravity radius [m]
$F_{spz}$	Cutting force [N]	$r_{sAB}$	Center of gravity radius of top jaw [m]
$m_{AB}$	Mass of one top jaw [kg]	$S_{sp}$	Safety factor for clamping force
$m_B$	Mass of chuck jaw set [kg]	$S_z$	Safety factor for machining
$M_c$	Centrifugal force torque [kgm]	$\Sigma_s$	Max. clamping force of chuck [N]

#### 6.3.1 Calculation of the required clamping force at a specified speed of rotation

The **initial clamping force**  $F_{sp0}$  is the total force impacting radially on the workpiece via the jaws due to actuation of the lathe chuck during shutdown. Under the influence of rotation, the jaw mass generates an additional centrifugal force. The centrifugal force reduces or increases the initial clamping force depending on whether clamping is from the outside inwards or from the inside outwards.

The sum of the initial clamping force  $F_{sp0}$  and the **total centrifugal force**  $F_c$  is the **effective clamping force**  $F_{sp}$ .

$$F_{sp} = F_{sp0} \mp F_c \text{ [N]}$$

(-) for clamping from the outside inwards

(+) for clamping from the inside outwards



#### **! DANGER**

**Risk to life and limb of the operating personnel and significant property damage when a certain RPM limit is exceeded! When clamping from the outside in, as the RPM increases, the effective clamping force decreases by the amount by which the centrifugal force increases (the forces are opposed). When the RPM limit is exceeded, the clamping force drops below the required minimum clamping force  $F_{spmin}$ . Consequently, the workpiece is released spontaneously.**

- Do not exceed the calculated RPM.
- Do not fall below the necessary minimum clamping force.

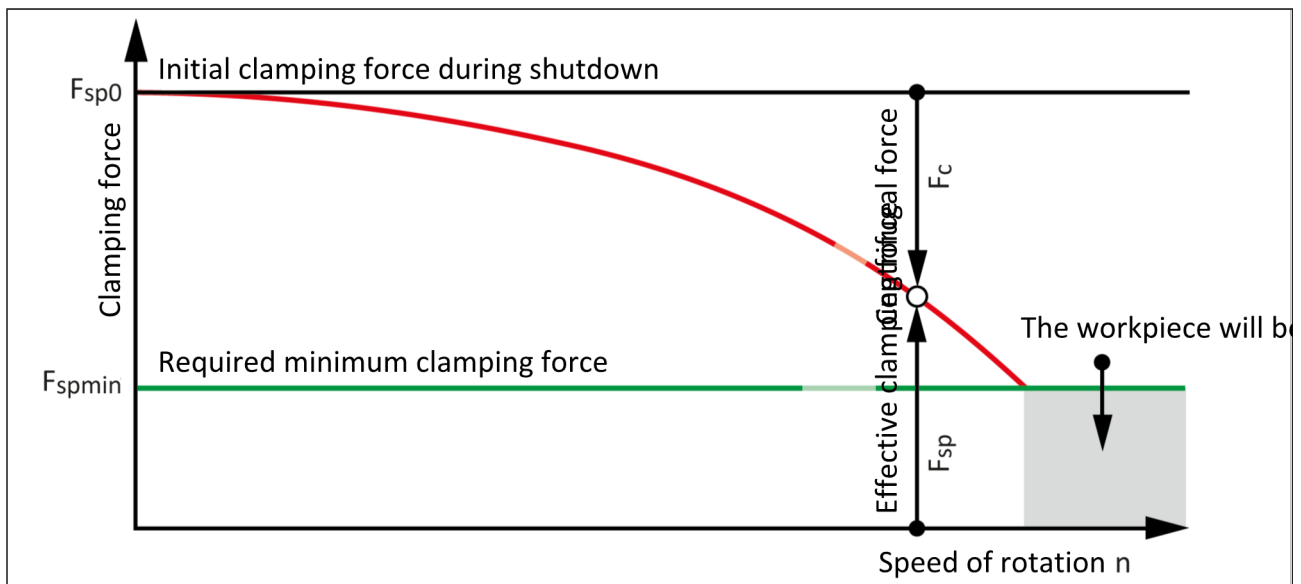

Reduction in effective clamping force by the magnitude of the total centrifugal force, for clamping from the outside inwards.

The required effective clamping force for machining  $F_{sp}$  is calculated from the product of the **machining force**  $F_{spz}$  and the **safety factor**  $S_z$ . This factor takes into account uncertainties in the calculation of the machining force. According to VDI 3106:  $S_z \geq 1.5$ .

$$F_{sp} = F_{spz} \cdot S_z \text{ [N]}$$

From this we can derive the calculation of the initial clamping force during shutdown:

$$F_{sp0} = S_{sp} \cdot (F_{sp} \pm F_c) \text{ [N]}$$

(+) for clamping from the outside inwards

(-) for clamping from the inside outwards



#### NOTICE

**This calculated force must not be larger than the maximum clamping force  $\Sigma S$  engraved on the chuck.**

See also "Chuck data" table ([👉 6.1, Page 17](#))

From the above formula it is evident that the sum of the effective clamping force  $F_{sp}$  and the total centrifugal force  $F_c$  is multiplied by the **safety factor for the clamping force**  $S_{sp}$ . According to VDI 3106, the following also applies here:  $S_{sp} \geq 1.5$ .

The **total centrifugal force**  $F_c$  is dependent on both the sum of the masses of all jaws and on the center of gravity radius and the RPM.

**NOTICE**

For safety reasons, in accordance with DIN EN 1550, the centrifugal force may be a maximum of 67% of the initial clamping force.

The formula for the calculation of the total centrifugal force  $F_c$  is:

$$F_c = \sum(m_B \cdot r_s) \cdot \left(\frac{\pi \cdot n}{30}\right)^2 = \sum M_c \cdot \left(\frac{\pi \cdot n}{30}\right)^2 \text{ [N]}$$

For this, **n** is the given speed of rotation in <sup>RPM</sup>. The product  $m_B \cdot r_s$  is referred to as the centrifugal force torque  $M_c$ .

$$M_c = m_B \cdot r_s \text{ [kgm]}$$

In case of lathe chucks with split chuck jaws, i.e., with base jaws and top jaws, for which the base jaws change their radial position only by the stroke amount, the **centrifugal torque of the base jaws  $M_{cGB}$**  and the **centrifugal torque of the top jaws  $M_{cAB}$**  need to be added:

$$M_c = M_{cGB} + M_{cAB} \text{ [kgm]}$$

The centrifugal torque of the base jaws  $M_{cGB}$  can be found in the table "Chuck data" ([🔗 6.1, Page 17](#)). The centrifugal torque of the top jaws  $M_{cAB}$  is calculated as per:

$$M_{cAB} = m_{AB} \cdot r_{sAB} \text{ [kgm]}$$

### 6.3.2 Calculation example: required initial clamping force $F_{sp0}$ for a given RPM $n$

The following data is known for the machining job:

- Gripping from the outside in (application-specific)
- Machining force  $F_{spz} = 3000 \text{ N}$  (application-specific)
- max. RPM  $n_{max} = 3200 \text{ RPM}$  ("Chuck data" table)
- RPM  $n = 1200 \text{ RPM}$  (application-specific)
- Mass of one (!) top jaw  $m_{AB} = 5.33 \text{ kg}$  (application-specific)
- Center of gravity radius of top jaw  $r_{sAB} = 0.107 \text{ m}$  (application-specific)
- Safety factor  $S_z = 1.5$  (according to VDI 3106)
- Safety factor  $S_{sp} = 1.5$  (according to VDI 3106)

**Note:** Masses of the jaw mounting screws and T-nuts are not taken into account.



First the required effective clamping force  $F_{sp}$  is calculated using the machining force stated:

$$F_{sp} = F_{spz} \cdot S_z = 3000 \cdot 1.5 \Rightarrow \mathbf{F_{sp} = 4500 \text{ N}}$$

Initial clamping force during shutdown:

$$F_{sp0} = S_{sp} \cdot (F_{sp} + F_c)$$

Calculation of total centrifugal force:

$$F_c = \sum M_c \cdot \left(\frac{\pi \cdot n}{30}\right)^2$$

For two-part chuck jaws, the following applies:

$$M_c = M_{cGB} + M_{cAB}$$

Centrifugal torque of base jaw and top jaw specified in "Chuck data" table:

$$\mathbf{M_{cGB} = 0.319 \text{ kgm}}$$

For the centrifugal torque of the top jaw, the following applies:

$$M_{cAB} = m_{AB} \cdot r_{sAB} = 5.33 \cdot 0.107 \Rightarrow \mathbf{M_{cAB} = 0.57 \text{ kgm}}$$

Centrifugal torque for one jaw:

$$M_c = 0.319 + 0.571 \Rightarrow \mathbf{M_c = 0.89 \text{ kgm}}$$

The chuck has 3 jaws, the total centrifugal torque is:

$$\sum M_c = 3 \cdot M_c = 3 \cdot 0.889 \Rightarrow \sum \mathbf{M_c = 2.667 \text{ kgm}}$$

The total centrifugal force can now be calculated:

$$F_c = \sum M_c \cdot \left(\frac{\pi \cdot n}{30}\right)^2 = 2.668 \cdot \left(\frac{\pi \cdot 1200}{30}\right)^2 \Rightarrow \mathbf{F_c = 42131 \text{ N}}$$

Initial clamping force during shutdown that was sought:

$$F_{sp0} = S_{sp} \cdot (F_{sp} + F_c) = 1.5 \cdot (4500 + 42131) \Rightarrow \mathbf{F_{sp0} = 69947 \text{ N}}$$

### 6.3.3 Calculation of the permissible speed of rotation $n_{perm}$ in case of a given initial clamping force $F_{sp0}$

The following formula can be used to calculate the permissible RPM for a given initial clamping force during shutdown:

$$n_{zul} = \frac{30}{\pi} \cdot \sqrt{\frac{F_{sp0} - (F_{spz} \cdot S_z)}{\sum M_c}} \quad [\text{min}^{-1}]$$



#### NOTICE

The calculated permissible RPM may not exceed the maximum RPM inscribed on the chuck for safety reasons!

### Example of calculation: Permissible RPM for a given effective clamping force

The following data is known from previous calculations:

- Initial clamping force during shutdown  $F_{sp0} = 17723 \text{ N}$
- Machining force for machining job  $F_{spz} 3000 \text{ N}$  (application-specific)
- Total centrifugal torque of all jaws  $\sum M_c = 2,668 \text{ kgm}$
- Safety factor  $S_z = 1.5$  (according to VDI 3106)
- Safety factor  $S_{sp} = 1.5$  (according to VDI 3106)

#### NOTE:

Masses of the jaw mounting screws and T-nuts are not taken into account.

Identifying the permissible RPM:

$$n_{zul} = \frac{30}{\pi} \cdot \sqrt{\frac{F_{sp0} - (F_{spz} \cdot S_z)}{\sum M_c}} = \frac{30}{\pi} \cdot \sqrt{\frac{69947 - (3000 \cdot 1.5)}{2.668}} \Rightarrow n_{zul} = 1495 \text{ min}^{-1}$$

The calculated RPM  $n_{perm} = 1495 \text{ RPM}$  is smaller than the maximum permissible RPM of the chuck  $n_{max} = 3200 \text{ RPM}$  (see "Chuck data" table ([↗ 6.1, Page 17](#))).

**This calculated RPM may be used.**

## 6.4 Accuracy classes

Tolerances for run-out accuracy and axial run-out accuracy correspond to the Technical Supply Terms for lathe chucks as per DIN ISO 3442-3.

## 6.5 Permitted imbalance

Rotating clamping stations without pallets and workpieces correspond to balancing quality class 6.3 (according to DIN ISO 21940-11). Residual imbalance risks may arise due to insufficient rotation compensation being achieved (see DIN EN 1550 6.2 e). This applies particularly to high speeds of rotation, asymmetrical workpieces or the use of lathe chucks that do not correspond to balancing grade 6.3, as well as uneven lubricant application. In order to prevent damage resulting from these residual risks, the entire rotor is to be dynamically balanced in accordance with DIN ISO 21940-11.

## 7 Attachment of the manual lathe chuck

The item numbers specified for the corresponding individual components relate to the drawing in chapter "Drawings" ([👉 12, Page 41](#)).

### 7.1 Handling prior to attachment

Before mounting on the lathe, remove the base jaws from the chuck, then re-install the base jaws and turn the spindle several times as far as it will go to the right and left.

- Use the spanner wrench to turn the spindle (item 8) as far as possible to the left.
- Press the pressure bolt (item 14) under the first jaw (item 4). The base jaw is now free to move.
- Remove the base jaw and push it into the chuck again while pressing the pressure bolt (item 14) until the front side of the jaw is at the outer marking line.
- The first tooth of the base jaw holds the locking slide (item 13) in the lower position and the actuating lock for the respective jaw is released.
- Proceed in this way for all three base jaws.

**The numbered jaws must be inserted into the correspondingly numbered guides (jaw 1 in guide 1 etc.).**

Finally, turn the spindle a few times as far as it will go to the right and left.

### 7.2 Preparing the chuck attachment

- Check the spindle nose or the ready-machined intermediate flange for radial and axial run-out. The permissible limit is 0.005 mm in accordance with DIN 6386 and ISO 3089.
- The contact surface must be chamfered and clean at the bore holes. Rectify any damage of the spindle nose supporting surfaces. For the flange spindle, check the contact surface with a straight edge.



**NOTICE**

**When mounting with the intermediate flange, never allow the outer rim of the chuck body to make contact. The flange must support on the entire surface.**

ROTA-S plus 2.0 chucks are delivered with different short taper mountings. For the type C bayonet mounting, for the type S Camlock mounting and with the intermediate flanges for type A short taper. (Our technical sales would be glad to answer any questions you may have.)

### 7.3 Assembly of the manual lathe chuck

Before putting on the chuck on the spindle nose, carefully clean the centering and contact surfaces of both parts and rub in some oil. While the chuck is lightly pressed on, there should be noticeable play in the taper and at most 0.02 mm play between the flat surfaces (feeler gauge).



**NOTICE**

**Danger of damage of the pressure bolt (item 14) when setting down the chuck on the pressure bolt (for example, for cleaning or maintenance).**

Never put the chuck onto the pressure bolt (item 14)!

## 8 Function

The item numbers specified for the corresponding individual components relate to the drawing in chapter "Drawings" ([☞ 12, Page 41](#)).

### 8.1 Handling and jaw change

#### NOTE:

**For rotating lathe chucks, the centrifugal forces applied can cause the indicator pin to emerge from the chuck body. When the lathe chuck comes to a stop, the indicator pin must be reinserted.**

- Use the spanner wrench to turn the spindle (item 8) as far as possible to the left. The indicator pin (item 17) protrudes from the chuck body by about 4 to 5 turns before the stop (gold-colored pin).

	<b>! WARNING</b>
	<p>If the indicator pin protrudes, the entire serration of the wedge bars (items 5 and 6) no longer engages into the base jaws. The base jaws are not sufficiently engaged by the wedge bars. Risk of injury from jaws and workpiece being flung out.</p> <ul style="list-style-type: none"> <li>• If the indicator pin protrudes, do not clamp the chuck and do not start up.</li> </ul>

- Once the spindle (item 8) has reached the stop, press the pressure bolt (item 14) under the base jaw. The corresponding jaw is released and can now be adjusted or exchanged.

	<b>NOTICE</b>
	<p>If the pressure bolt (item 14) is stuck or does not move easily, it must be removed and cleaned (see chapter "Disassembling and assembling the chuck" (<a href="#">☞ 9.1, Page 35</a>)). Do not use force (for example, hammer blows etc.) to loosen the pressure bolt, since this could damage the slide (item 13), which in turn could impair the safety mechanism.</p>

**Oil the cleaned pressure bolt; do not grease with chuck grease!**

- Adjust exchanged jaws until the desired clamping diameter has been reached. The slides (item 12) must snap in when doing this.

	<b>NOTICE</b>
	<p><b>Actuating the chuck if a jaw is not engaged will damage the chuck!</b></p> <p>Manually move the jaw back and forth without actuating the pressure bolt. This ensures that the jaw is engaged. The pressure bolt has to be in the initial position.</p>

**For all the wedge bar teeth (items 5 and 6) to be supportive, the base jaws in the guides must always be inserted at least up to the marking line on the chuck body (item 1) (see Fig. "Jaw change"). All jaws have to be at the same marking line. An additional actuating lock prevents the spindle from being turned to the right without chuck jaws.**

	<b>NOTICE</b>
	<p><b>If force is used to continue turning, the chuck will be damaged and the jaw lock function will no longer be active.</b></p> <p><b>Do not forcefully turn the spindle further!</b></p>

**Only after all the chuck jaws have been inserted into the guide will the actuating lock be unlocked. Then the wedge bars can be shifted into working position. (Turn spindle to the right!)**

**In the event of noticeable resistance (jaw not engaged), do not turn further forcefully. Slightly move the base jaw until it engages.**

The base jaws fit into the chuck in both directions. They can be turned around.

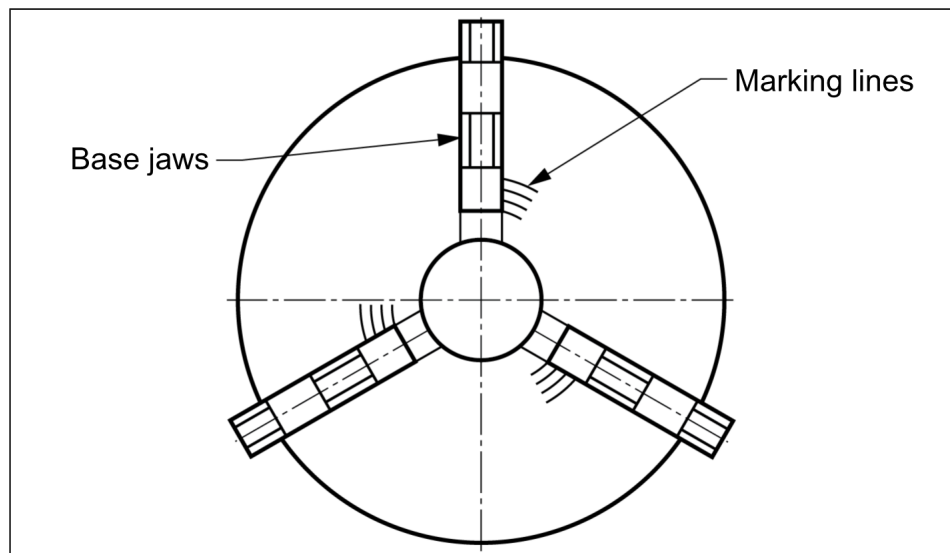

Jaw change

If you turn the spindle to the right, the indicator pin (item 17) will protrude from the chuck body (item 1) (gold-colored pin).



### **⚠ WARNING**

**If the indicator pin protrudes, the entire serration of the wedge bars (items 5 and 6) no longer engages into the base jaws. The base jaws are not sufficiently engaged by the wedge bars. Risk of injury from jaws and workpiece being flung out.**

- If the indicator pin protrudes, do not clamp the chuck and do not start up.

## 8.2 Important notes

**When working with a very short opening stroke or large series, lubrication grease may be pressed out between the loaded surfaces of the chuck gear. In this case efficiency will decrease!** Following a number of clampings, activate the chuck several times without a workpiece inserted at full stroke so that the grease can be distributed evenly again on the sliding areas on the inside of the chuck. The chuck will then attain its full clamping force again.

- Never remove the base jaws without actuating the pressure bolt (item 14).

- Regularly adjust the lathe chuck during operation to compensate for loss of clamping force caused by vibrations.
- Following a longer period of shutdown (more than 8 hours), always re-tension the clamped chuck in order to compensate for the spindle settling and the resulting loss of clamping force.
- When gripping the spanner wrench, do not tighten with an extension pipe or using hammer blows! Only grip using the flange-mounted chuck!
- Do not flange-mount the chuck against the edge of the chuck body!
- Do not grip the base jaws outside of the marking lines ([☞ 8.1, Page 29](#))!
- Do not use force (e.g. hammer blows) to move jaws that are difficult to move! Clean the guides and jaws.
- Subsequently delivered hard top jaws (type SHF) or unsplit, hard jaws (type STF) must be ground in the chuck for run-out accuracy.
- For precise clamping, do not remove the ground top jaws from the base jaws. This will result in loss of run-out accuracy. Use a different set of jaws when changing the jaws.
- When re-equipping from cylindrical mounting to short-taper flange, the lid (item 2) must be removed if the centering lid is used.

### 8.3 Checking the chuck

The ROTA-S plus 2.0 manual lathe chuck can only be checked in flange-mounted condition. The round and planar surfaces in the rear chuck body area must run true.

The jaws must be just as easy to move after attachment as they were before ([☞ 9.1, Page 35](#)).

**If the jaws are more difficult to move than before attachment, the chuck body has been incorrectly attached. The chuck may have become twisted.**



## 8.4 True running check

(on delivery of ROTA-S plus 2.0 with STF/SHF hard jaws ground on the chuck)

To check the radial and axial run-out accuracy, hardened and ground test pins or test disks are clamped (see Fig. "True running check"). The torque ( $M_d$ ) at the wrench when clamping the test pins and test disks is about 67% of the maximum chuck actuating torque. The values, the diameter of the test shafts as well as the position of the measuring point for the jaws can be seen in the table below.

If the permissible radial and axial run-out error (see table) is exceeded, check the following points:

- Applied wrench torque ( $M_d$ )
- Correct mounting of the chuck
- Test pins and test disks deviate from the factory specification

**Table of the maximum permissible radial and axial run-out error for the ROTA-S plus 2.0 chuck with STF or SHF jaws**

Chuck size	160-42	200-52	250-62	315-92
Jaw type	STF-160	STF-200	STF-250	STF-315
	SHF-160	SHF-200	SHF-250	SHF-315
$M_d$ [Nm]	40	70	80	90
L [mm]	60	80	80	120
d (STF) [mm]	∅ 34	∅ 41	∅ 41	∅ 55
d (SHF) [mm]	∅ 34	∅ 41	∅ 41	∅ 55
$T_{R1}$ max [mm]	0.03	0.03	0.03	0.04
D (STF) [mm]	∅ 140	∅ 160	∅ 210	∅ 243
D (SHF) [mm]	∅ 140	∅ 140	∅ 210	∅ 243
W [mm]	20	25	25	35
$T_{P1}$ max [mm]	0.02	0.02	0.02	0.03

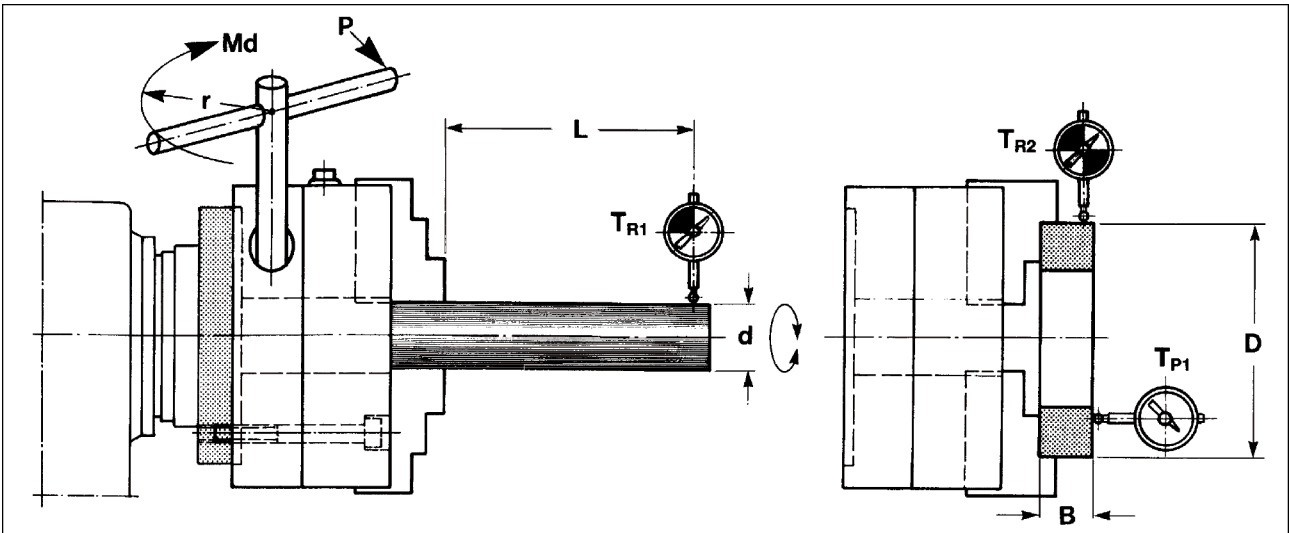

True running check

## 9 Maintenance

The item numbers specified for the corresponding individual components relate to the drawing in chapter "Drawings" ([👉 12, Page 41](#)).

A high load bearing capacity with a secure workpiece clamping device can only be guaranteed with regular lubrication using a high-performance lubricant.

For this reason, it is recommended to regularly clean the chuck and lubricate it using SCHUNK LINOMAX plus special grease.

	<b>⚠ CAUTION</b>
	<p><b>Allergic reactions if lubricating grease comes into contact with the skin.</b></p> <p>Wear protective gloves.</p>

The chuck will have to be disassembled and cleaned at regular intervals according to its application.

### 9.1 Disassembling and assembling the chuck

#### Disassembly

When replacing spare parts or cleaning, the chuck will have to be disassembled.

- First remove the manual chuck from the lathe.

Note for the corresponding mountings:

- For direct mounting in acc. with DIN ISO 702-1:  
Evenly loosen the mounting screws (item 35) and remove the chuck from the spindle.
- For direct mounting in acc. with DIN ISO 702-3 (bayonet):  
Loosen the flanged nuts, turn the bayonet disk and take the chuck out of the spindle.
- For direct mounting in acc. with DIN ISO 702-2 (Camlock):  
Unlock the camlock bolts and take the chuck out of the spindle.

**⚠ WARNING**
**Risk of injury due to dropping the manual lathe chuck during transport, installation or removal**

During transport and when installing or detaching the manual chuck, ensure it does not fall off.

- Remove the jaws from the guideways (see chapter "Handling and jaw changes" ([👉 8.1, Page 29](#)))
- Place the chuck on its front, undo the screws (item 34) and remove the cover (item 2).
- When taking out the drive ring (item 3), pay attention to the indicator pin (item 17) which has been pre-loaded by the spring (item 38).
- Take the spring and the indicator pin out of the bore hole in the chuck body (item 1).
- Pull off the sliding blocks (item 7) from the wedge bars (items 5 and 6) and carefully remove the O-rings (item 39).
- Remove the cylindrical pin (item 30).
- Insert the assembly key (item 99) using the spindle's hexagonal head (item 8) and unscrew the spindle screw (item 8) with the actuating key. The spindle (item 8) can now be completely screwed out of the wedge bar (item 5) with the actuating key.
- The pressure bolts (item 14) are pre-loaded by the springs (item 31). After the cylindrical pins (item 45) are driven out of the chuck body with a suitable sliding hammer, the springs (item 31) and the pressure bolts (item 14) can be removed.
- Carefully remove the wedge bars (items 5 and 6) from the chuck body (item 1) and take off the locking slide (item 13) with the spring (item 32), the traverse slide (item 15) and the slide (item 12).
- Unscrew the screws (item 36) and remove the wipers (item 11).
- Take the seat of bearing (item 10) out of the chuck body.

The chuck is now completely disassembled.

Clean all parts carefully with degreasing agent and check for wear and damage.

**Replace damaged parts with original SCHUNK spare parts only!**

Before installation, lubricate all individual components with LINOMAX plus grease.

**Assembly**

The chuck is assembled in the reverse order. Observe the following when doing this:

- **Do not forget any parts! Even small components are essential for the safety of the lathe.**
- **When assembling the spindle (item 8), be sure not to tighten the spindle nut (item 9).**  
Turn the spindle nut (item 9) on the block and then turn it back until a surface on the spindle nut (item 9) can be seen through the hole of the cylindrical pin (item 30) in the chuck body (item 1). Insert the cylindrical pin (item 30) in this orientation.
- When inserting the drive ring (item 3), the position of the control area for the indicator pin (item 17) must be noted. If the drive ring (item 3) is incorrectly mounted, then the indicator pin (item 17) is not pulled in during the actuation of the chuck.

**9.2 Jaw change**

Clean and lubricate jaws if there is no film of grease.

**9.3 At least once a month**

Lubricate the chuck at the two lubrication nipples (item 37) on the circumference of the chuck body (item 1) using a manual press. Use SCHUNK LINOMAX plus special grease as lubricant.

The chuck must be in fully the open position (jaw change position) so that all the important areas are covered with grease by the lubrication system.

- The functional surfaces of the wedge bars (items 5 and 6) and the drive ring (item 7) are reached via the lubrication nipple opposite jaw 1. The second greasing area supplies grease to the spindle bearings and the spindle thread.
- After lubricating, open and close the chuck 2 – 3 times without a workpiece to evenly distribute the grease across all the functional surfaces.

#### 9.4 In the case of decreasing clamping force or after about 200 operating hours

If the clamping force decreases, the inside of the chuck is contaminated or the coolant has washed out or decomposed the grease.

In this case, disassemble the chuck, carefully clean all parts with degreasing agent and check for wear and damage.

**Replace damaged parts with original SCHUNK spare parts only!**

Before installation, lubricate all individual components with SCHUNK LINOMAX plus special grease.

This cleaning procedure should be performed about every 200 operating hours, depending on the extent of stress on the chuck.

#### 9.5 Maintenance intervals

**Lubricating the greasing areas:**

Lubrication interval	Demands
every 25 hours	normal / use of coolant
every 8 hours	high / use of coolant
after 1200 hours or when needed	Full cleaning with disassembly of chuck depending on type of contamination and quantity

## 10 Disposal

After decommissioning, place the chuck in a position that enables any liquids in the chuck to drain out.

- Collect the escaping liquids and dispose of them properly in line with the statutory provisions.
- Remove any identifiable plastic or aluminum parts installed in or on the chuck and dispose of them properly in line with the statutory provisions.
- Dispose of the chuck's metal parts as scrap metal.

Alternatively, you can return the chuck to SCHUNK for proper disposal.

## 11 Spare parts

When ordering spare parts, it imperative to state the type, size, and, above all, the manufacturing no. of the chuck.

Seals, sealing elements, screw connections, springs, bearings, screws, wiper bars and parts that come into contact with the workpiece are not covered by the warranty.

Item	Designation	Quantity	
		3-jaw	2-jaw
1	Chuck body	1	1
2	Cover	1	1
3	Drive ring	1	1
4	Base jaws	3	2
5	Wedge bar with thread	1	1
6	Wedge bar	2	1
7	Sliding block	3	2
8	Spindle	1	1
9	Spindle nut	1	1
10	Seat of bearing	1	1
11	Wiper (starting for size 200)	3	2
12	Slide	3	2
13	Locking slide	3	2
14	Pressure bolt	3	2
15	Traverse slide	3	2
17	Indicator pin	1	1
30	Cylindrical pin	1	1
31	Compression spring for pressure bolt	3	2
32	Compression spring for locking slide	3	2
33	Spring-loaded pressure piece	3	2
34	Cylindrical screw	3	4
35	Cylindrical screw	3	4
36	Flat lens head screw (starting from size 200)	12	8
37	Lubrication nipple	2	2
38	Compression spring for indicator pin	1	1
39	O-ring	3	2
45	Cylindrical pin	3	2
50	Eye bolt (starting from size 250)	1	1
55	Insert	3	2
99	Assembly key	1	1



## 12 Assembly drawing

