

Assembly and Operating Manual

SRU-plus20 - 60

Pneumatic Swivel Unit



Imprint

Copyright:

This manual is protected by copyright. The author is SCHUNK GmbH & Co. KG. All rights reserved. Any reproduction, processing, distribution (making available to third parties), translation or other usage - even excerpts - of the manual is especially prohibited and requires our written approval.

Technical changes:

We reserve the right to make alterations for the purpose of technical improvement.

Document number: 389443

Version: 09.00 | 19/08/2019 | en

© SCHUNK GmbH & Co. KG

All rights reserved.

Dear Customer,

thank you for trusting our products and our family-owned company, the leading technology supplier of robots and production machines.

Our team is always available to answer any questions on this product and other solutions. Ask us questions and challenge us. We will find a solution!

Best regards,

Your SCHUNK team

SCHUNK GmbH & Co. KG
Spann- und Greiftechnik

Bahnhofstr. 106 – 134
D-74348 Lauffen/Neckar

Tel. +49-7133-103-0

Fax +49-7133-103-2399

info@de.schunk.com

schunk.com

Table of Contents

| | | |
|----------|---|-----------|
| 1 | General | 6 |
| 1.1 | About this manual | 6 |
| 1.1.1 | Presentation of Warning Labels | 6 |
| 1.1.2 | Applicable documents | 7 |
| 1.1.3 | Sizes | 7 |
| 1.1.4 | Variants..... | 7 |
| 1.2 | Warranty | 7 |
| 1.3 | Scope of delivery | 8 |
| 1.3.1 | Accessories pack..... | 8 |
| 1.4 | Accessories | 9 |
| 1.4.1 | Seal kit | 9 |
| 2 | Basic safety notes | 10 |
| 2.1 | Intended use..... | 10 |
| 2.2 | Not intended use..... | 10 |
| 2.3 | Constructional changes | 10 |
| 2.4 | Spare parts | 10 |
| 2.5 | Environmental and operating conditions | 11 |
| 2.6 | Personnel qualification..... | 11 |
| 2.7 | Personal protective equipment..... | 12 |
| 2.8 | Notes on safe operation | 12 |
| 2.9 | Transport | 13 |
| 2.10 | Malfunctions..... | 13 |
| 2.11 | Disposal | 13 |
| 2.12 | Fundamental dangers..... | 14 |
| 2.12.1 | Protection during handling and assembly | 14 |
| 2.12.2 | Protection during commissioning and operation | 15 |
| 2.12.3 | Protection against dangerous movements..... | 15 |
| 2.12.4 | Protection against electric shock..... | 16 |
| 2.13 | Notes on particular risks..... | 17 |
| 3 | Technical data | 19 |
| 3.1 | Type key..... | 19 |
| 3.2 | Basic data | 20 |
| 4 | Design and description | 21 |
| 4.1 | Design | 21 |
| 4.1.1 | Variant with electrical feed-through (EDF) | 22 |
| 4.2 | Description | 23 |
| 5 | Assembly | 24 |
| 5.1 | Assembling and connecting..... | 24 |
| 5.2 | Connections..... | 26 |

| | | |
|----------|--|-----------|
| 5.2.1 | Mechanical connection..... | 26 |
| 5.2.2 | Pneumatic connection..... | 31 |
| 5.2.3 | Electrical connection | 33 |
| 5.3 | Mounting separating sleeve | 35 |
| 5.4 | Settings..... | 36 |
| 5.4.1 | Adjust swivel angle | 38 |
| 5.4.2 | Adjust swiveling speed | 40 |
| 5.4.3 | Adjust absorber stroke | 41 |
| 5.4.4 | Set center position..... | 43 |
| 5.4.5 | Set locked center position | 44 |
| 5.5 | Installing the sensors | 45 |
| 5.5.1 | Overview of sensors | 45 |
| 5.5.2 | Mounting MMS 22 magnetic switch..... | 46 |
| 5.5.3 | Mounting MMS 22-PI1 magnetic switch | 48 |
| 5.5.4 | Mounting inductive proximity switch IN 80 | 50 |
| 6 | Start-up | 52 |
| 6.1 | Setting ranges of the variants..... | 52 |
| 6.2 | Base unit..... | 53 |
| 6.3 | Center position | 53 |
| 6.4 | Locked center position | 55 |
| 6.5 | Locked center position with separate piston chambers..... | 57 |
| 7 | Troubleshooting | 59 |
| 7.1 | Product does not move smoothly to the end positions | 59 |
| 7.2 | Product does not travel through the rotating angle | 59 |
| 7.3 | Product rotates jerkily | 59 |
| 7.4 | Product does not move | 60 |
| 7.5 | Torque is diminishing | 60 |
| 8 | Maintenance | 61 |
| 8.1 | Notes | 61 |
| 8.2 | Maintenance interval | 61 |
| 8.3 | Lubricants/Lubrication points (basic lubrication)..... | 62 |
| 8.4 | Inspect and set shock absorbers | 63 |
| 8.4.1 | Inspect shock absorbers | 63 |
| 8.4.2 | Set shock absorber overhang | 63 |
| 8.4.3 | Shock absorber types and overlap | 64 |
| 8.5 | Servicing shock absorber | 66 |
| 8.5.1 | Servicing shock absorber (SRU-plus 20-W)..... | 66 |
| 8.5.2 | Servicing the shock absorber (SRU-plus 20-S) | 67 |
| 8.6 | Replace shock absorber..... | 68 |
| 8.6.1 | Replace shock absorber (base unit) | 68 |
| 8.6.2 | Replacing external shock absorber (locked center position) | 69 |

| | | |
|----------|---|-----------|
| 8.6.3 | Replace internal shock absorber (locked center position)..... | 70 |
| 8.7 | Disassembly and assembly | 71 |
| 8.7.1 | Dismantling and assembling rotary actuator (base unit) | 71 |
| 8.7.2 | Dismantle and assemble rotary actuator (center position/locked center position) | 72 |
| 8.7.3 | Dismantling and assembling rotary actuator (fluid feed-through)..... | 73 |
| 8.7.4 | Dismantling and assembling rotary actuator (EDF) | 74 |
| 8.8 | Assembly drawings | 75 |
| 8.8.1 | Overview of the components | 75 |
| 8.8.2 | Overview of the components (EDF)..... | 79 |
| 9 | Translation of original declaration of incorporation | 85 |
| 9.1 | Annex to Declaration of Incorporation..... | 86 |

1 General

1.1 About this manual

This manual contains important information for a safe and appropriate use of the product.

This manual is an integral part of the product and must be kept accessible for the personnel at all times.

Before starting work, the personnel must have read and understood this operating manual. Prerequisite for safe working is the observance of all safety instructions in this manual.

Illustrations in this manual are provided for basic understanding and may differ from the actual product design.

In addition to these instructions, the documents listed under [Applicable documents](#) [► 7] are applicable.

1.1.1 Presentation of Warning Labels

To make risks clear, the following signal words and symbols are used for safety notes.



⚠ DANGER

Danger for persons!

Non-observance will inevitably cause irreversible injury or death.



⚠ WARNING

Dangers for persons!

Non-observance can lead to irreversible injury and even death.



⚠ CAUTION

Dangers for persons!

Non-observance can cause minor injuries.

CAUTION

Material damage!

Information about avoiding material damage.

1.1.2 Applicable documents

- General terms of business *
- Catalog data sheet of the purchased product *

The documents marked with an asterisk (*) can be downloaded on our homepage **schunk.com**

1.1.3 Sizes

This operating manual applies to the following sizes:

- SRU-plus 20
- SRU-plus 25
- SRU-plus 30
- SRU-plus 35
- SRU-plus 40
- SRU-plus 50
- SRU-plus 60

1.1.4 Variants

This operating manual applies to the following variations:

- SRU-plus
- SRU-plus rotating angle 90°
- SRU-plus rotating angle 180°
- SRU-plus end position adjustability 3°
- SRU-plus end position adjustability 90°
- SRU-plus with fluid feed-through
- SRU-plus with pneumatic center position (M)
- SRU-plus with locked center position (VM)
- SRU-plus with electrical feed-through (EDF)
- SRU-plus ATEX (EX)

1.2 Warranty

If the product is used as intended, the warranty is valid for 24 months from the ex-works delivery date under the following conditions:

- Observe the specified maintenance and lubrication intervals
- Observe the ambient conditions and operating conditions

Parts touching the workpiece and wear parts are not included in the warranty.

1.3 Scope of delivery

The scope of delivery includes

- Pneumatic swivel unit SRU-plus in the version ordered
- Assembly and Operating Manual
- Accessory pack

1.3.1 Accessories pack

Id-No. Accessory pack SRU-plus

| 20 | 25 | 30 | 35 | 40 | 50 | 60 |
|---|----|---------|---------|---------|---------|---------|
| Without fluid feed-through | | | | | | |
| 5514981 | | 5518653 | 5514989 | 5514993 | 5514997 | 5515001 |
| With fluid feed-through | | | | | | |
| 5514982 | | 5518654 | 5514990 | 5514994 | 5514998 | 5515002 |
| With center position | | | | | | |
| 5516590 | | 5518657 | 5516594 | 5516596 | 5516598 | 5516600 |
| With locked center position | | | | | | |
| 5514983 | | 5518655 | 5514991 | 5514995 | 5514999 | 5515003 |
| With fluid feed-through and center position | | | | | | |
| 5516591 | | 5518658 | 5516595 | 5516597 | 5516599 | 5516601 |
| With fluid feed-through and locked center position | | | | | | |
| 5514984 | | 5518656 | 5514992 | 5514996 | 5515000 | 5515004 |

1.4 Accessories

A wide range of accessories are available for this product
For information regarding which accessory articles can be used
with the corresponding product variants, see catalog data sheet.

1.4.1 Seal kit

Id-No. Seal kit SRU-plus

| 20 | 25 | 30 | 35 | 40 | 50 | 60 |
|---|---------|---------|---------|---------|---------|---------|
| Basic sealing kit | | | | | | |
| 0371000 | 0371004 | 5518598 | 0371008 | 0371012 | 0371016 | 0371020 |
| With center position | | | | | | |
| 5519788 | 5519792 | 5519798 | 5519800 | 5519804 | 5519808 | 5519812 |
| With locked center position | | | | | | |
| 5519789 | 5519793 | 5519799 | 5519801 | 5519805 | 5519809 | 5519813 |
| With fluid feed-through | | | | | | |
| 0371003 | 0371007 | 5518599 | 0371011 | 0371015 | 0371019 | 0371023 |
| With fluid feed-through and center position | | | | | | |
| 5519790 | 5519794 | 5519796 | 5519802 | 5519806 | 5519810 | 5519814 |
| With fluid feed-through and locked center position | | | | | | |
| 5519791 | 5519795 | 5519797 | 5519803 | 5519807 | 5519811 | 5519815 |

ID no. Seal kit SRU-plus with EDF

| 20 | 25 | 30 | 35 | 40 | 50 | 60 |
|---|---------|---------|---------|---------|---------|---------|
| Basic sealing kit | | | | | | |
| 5521583 | 5521583 | 5521585 | 5521587 | 5521589 | 5521591 | 5521591 |
| Basic sealing kit + monitoring set | | | | | | |
| 5521584 | 5521584 | 5521586 | 5521588 | 5521590 | 5521592 | 5521592 |

2 Basic safety notes

2.1 Intended use

The product may only be used for swiveling permissible attachment parts or workpieces.

- The product may only be used within the scope of its technical data, [Technical data](#) [► 19].
- When implementing and operating components in safety-related parts of the control systems, the basic safety principles in accordance with DIN EN ISO 13849-2 apply. The proven safety principles in accordance with DIN EN ISO 13849-2 also apply to categories 1, 2, 3 and 4.
- The product is intended for installation in a machine/system. The applicable guidelines must be observed and complied with.
- The product is intended for industrial and industry-oriented use.
- Appropriate use of the product includes compliance with all instructions in this manual.

2.2 Not intended use

Inappropriate use includes using the product as a cutting tool or drilling tool, for example.

- Any utilization that exceeds or differs from the appropriate use is regarded as misuse.

2.3 Constructional changes

Implementation of structural changes

By conversions, changes, and reworking, e.g. additional threads, holes, or safety devices can impair the functioning or safety of the product or damage it.

- Structural changes should only be made with the written approval of SCHUNK.

2.4 Spare parts

Use of unauthorized spare parts

Using unauthorized spare parts can endanger personnel and damage the product or cause it to malfunction.

- Use only original spare parts or spares authorized by SCHUNK.

2.5 Environmental and operating conditions

Required ambient conditions and operating conditions

Incorrect ambient and operating conditions can make the product unsafe, leading to the risk of serious injuries, considerable material damage and/or a significant reduction to the product's life span.

- Make sure that the product is a sufficient size for the application.
- Ensure that maintenance and lubrication intervals are observed, [Maintenance](#) [▶ 61].
- Make sure that the environment is free from splash water and vapors as well as from abrasion or processing dust. Exceptions are products that are designed especially for contaminated environments.

2.6 Personnel qualification

Inadequate qualifications of the personnel

If the personnel working with the product is not sufficiently qualified, the result may be serious injuries and significant property damage.

- All work may only be performed by qualified personnel.
- Before working with the product, the personnel must have read and understood the complete assembly and operating manual.
- Observe the national safety regulations and rules and general safety instructions.

The following personal qualifications are necessary for the various activities related to the product:

| | |
|--|---|
| Trained electrician | Due to their technical training, knowledge and experience, trained electricians are able to work on electrical systems, recognize and avoid possible dangers and know the relevant standards and regulations. |
| Qualified personnel | Due to its technical training, knowledge and experience, qualified personnel is able to perform the delegated tasks, recognize and avoid possible dangers and knows the relevant standards and regulations. |
| Instructed person | Instructed persons were instructed by the operator about the delegated tasks and possible dangers due to improper behaviour. |
| Service personnel of the manufacturer | Due to its technical training, knowledge and experience, service personnel of the manufacturer is able to perform the delegated tasks and to recognize and avoid possible dangers. |

2.7 Personal protective equipment

Use of personal protective equipment

Personal protective equipment serves to protect staff against danger which may interfere with their health or safety at work.

- When working on and with the product, observe the occupational health and safety regulations and wear the required personal protective equipment.
- Observe the valid safety and accident prevention regulations.
- Wear protective gloves to guard against sharp edges and corners or rough surfaces.
- Wear heat-resistant protective gloves when handling hot surfaces.
- Wear protective gloves and safety goggles when handling hazardous substances.
- Wear close-fitting protective clothing and also wear long hair in a hairnet when dealing with moving components.

2.8 Notes on safe operation

Incorrect handling of the personnel

Incorrect handling and assembly may impair the product's safety and cause serious injuries and considerable material damage.

- Avoid any manner of working that may interfere with the function and operational safety of the product.
- Use the product as intended.
- Observe the safety notes and assembly instructions.
- Do not expose the product to any corrosive media. This does not apply to products that are designed for special environments.
- Eliminate any malfunction immediately.
- Observe the care and maintenance instructions.
- Observe the current safety, accident prevention and environmental protection regulations regarding the product's application field.

2.9 Transport

Handling during transport

Incorrect handling during transport may impair the product's safety and cause serious injuries and considerable material damage.

- When handling heavy weights, use lifting equipment to lift the product and transport it by appropriate means.
- Secure the product against falling during transportation and handling.
- Stand clear of suspended loads.

2.10 Malfunctions

Behavior in case of malfunctions

- Immediately remove the product from operation and report the malfunction to the responsible departments/persons.
- Order appropriately trained personnel to rectify the malfunction.
- Do not recommission the product until the malfunction has been rectified.
- Test the product after a malfunction to establish whether it still functions properly and no increased risks have arisen.

2.11 Disposal

Handling of disposal

The incorrect handling of disposal may impair the product's safety and cause serious injuries as well as considerable material and environmental harm.

- Follow local regulations on dispatching product components for recycling or proper disposal.

2.12 Fundamental dangers

General

- Observe safety distances.
- Never deactivate safety devices.
- Before commissioning the product, take appropriate protective measures to secure the danger zone.
- Disconnect power sources before installation, modification, maintenance, or calibration. Ensure that no residual energy remains in the system.
- If the energy supply is connected, do not move any parts by hand.
- Do not reach into the open mechanism or movement area of the product during operation.

2.12.1 Protection during handling and assembly

Incorrect handling and assembly

Incorrect handling and assembly may impair the product's safety and cause serious injuries and considerable material damage.

- Have all work carried out by appropriately qualified personnel.
- For all work, secure the product against accidental operation.
- Observe the relevant accident prevention rules.
- Use suitable assembly and transport equipment and take precautions to prevent jamming and crushing.

Incorrect lifting of loads

Falling loads may cause serious injuries and even death.

- Stand clear of suspended loads and do not step into their swiveling range.
- Never move loads without supervision.
- Do not leave suspended loads unattended.

2.12.2 Protection during commissioning and operation

Falling or violently ejected components

Falling and violently ejected components can cause serious injuries and even death.

- Take appropriate protective measures to secure the danger zone.
- Never step into the danger zone during operation.

2.12.3 Protection against dangerous movements

Unexpected movements

Residual energy in the system may cause serious injuries while working with the product.

- Switch off the energy supply, ensure that no residual energy remains and secure against inadvertent reactivation.
- Never rely solely on the response of the monitoring function to avert danger. Until the installed monitors become effective, it must be assumed that the drive movement is faulty, with its action being dependent on the control unit and the current operating condition of the drive. Perform maintenance work, modifications, and attachments outside the danger zone defined by the movement range.
- To avoid accidents and/or material damage, human access to the movement range of the machine must be restricted. Limit/prevent accidental access for people in this area due through technical safety measures. The protective cover and protective fence must be rigid enough to withstand the maximum possible movement energy. EMERGENCY STOP switches must be easily and quickly accessible. Before starting up the machine or automated system, check that the EMERGENCY STOP system is working. Prevent operation of the machine if this protective equipment does not function correctly.

2.12.4 Protection against electric shock

Possible electrostatic energy

Components or assembly groups may become electrostatically charged. When the electrostatic charge is touched, the discharge may trigger a shock reaction leading to injuries.

- The operator must ensure that all components and assembly groups are included in the local potential equalisation in accordance with the applicable regulations.
- While paying attention to the actual conditions of the working environment, the potential equalisation must be implemented by a specialist electrician according to the applicable regulations.
- The effectiveness of the potential equalisation must be verified by executing regular safety measurements.

2.13 Notes on particular risks



⚠ DANGER

Risk of fatal injury from suspended loads!

Falling loads can cause serious injuries and even death.

- Stand clear of suspended loads and do not step within their swiveling range.
- Never move loads without supervision.
- Do not leave suspended loads unattended.
- Wear suitable protective equipment.



⚠ WARNING

Risk of injury from objects falling and being ejected!

Falling and ejected objects during operation can lead to serious injury or death.

- Take appropriate protective measures to secure the danger zone.



⚠ WARNING

Risk of injury due to unexpected movements!

If the power supply is switched on or residual energy remains in the system, components can move unexpectedly and cause serious injuries.

- Before starting any work on the product: Switch off the power supply and secure against restarting.
- Make sure, that no residual energy remains in the system.



⚠ WARNING

Risk of injury from sharp edges and corners!

Sharp edges and corners can cause cuts.

- Use suitable protective equipment.



⚠ WARNING

Risk of burns through contact with hot surfaces!

The product can heat up considerably during operation. Touching hot surfaces can cause burns.

- Do not touch hot surfaces.
 - Let them cool down before working on the product.
 - Wear appropriate safety equipment.
-



⚠ WARNING

Risk of injury from parts coming loose!

If the shock absorbers are faulty, the product can become damaged. Parts coming loose in this way can lead to injuries.

- Regularly check the components for wear and damage.
-



⚠ WARNING

Risk of injury if the condition or behavior of the product is undefined!

Cutting off the compressed air supply in an uncontrolled manner could lead to undefined states and behavior. This may cause personal injury or material damage.

- The operator must define suitable emergency stop and restarting strategies.
 - ✓ Emergency stop strategies: e.g. by means of controlled shut down
 - ✓ Restarting strategies: e.g. using pressure build-up valves or suitable valve switching sequences
-

3 Technical data

3.1 Type key

| | SRU-plus | 20 | -W- | 180 | -3- | M | -4- | EX | M8 | -AS |
|--|----------|----------------------------|-----------------------------------|-------------|-----------|--|--|----------------|---|----------------|
| Size | | 20 25 30 35 40 50 60 | | | | | | | | |
| Damping type | | | S = speed W = soft H = hard | | | | | | | |
| Swivel angle | | | | 90° 180° | | | | | | |
| End position adjustability | | | | | 3° 90° | | | | | |
| Center position | | | | | | - = none M = pneumatic VM = locked | | | | |
| Fluid feed-through | | | | | | | - = none 4 = 4 lines for the sizes 20 – 35 8 = 8 lines for the sizes 40 – 63 | | | |
| Explosion-protected variant | | | | | | | | - = none EX | | |
| Electrical feed-through | | | | | | | | | - = none M5 = M5 plug on rotation side M8 = M8 plug on rotation side M12 = M12 plug on rotation side | |
| Attachment kit inductive proximity switch | | | | | | | | | | - = none AS |

Type key

3.2 Basic data



⚠ DANGER

Danger of explosion in potentially explosive areas!

- Observe supplementary sheet for products with explosion-resistant versions "SRU-plus -...-EX".

| Designation | Value |
|------------------------|--|
| Noise emission [dB(A)] | ≤ 70 |
| Pressure medium | Compressed air, compressed air quality according to ISO 8573-1:7 4 4 |
| Min. pressure [bar] | See catalog data sheet |
| Max. pressure [bar] | See catalog data sheet |

Basic EDF data

| Designation | Value |
|--|-------|
| Max. voltage [V] | 24 |
| Max. current per wire [A] | 1 |
| Maximum transmission rate PROFIBUS [MBaud] | 1.5 |

The catalog data sheet contains diagrams for designing the maximum permissible mass moment of inertia.

The SCHUNK contact person provides support for designing further applications.

More technical data is included in the catalog data sheet.

Whichever is the latest version.

4 Design and description

4.1 Design

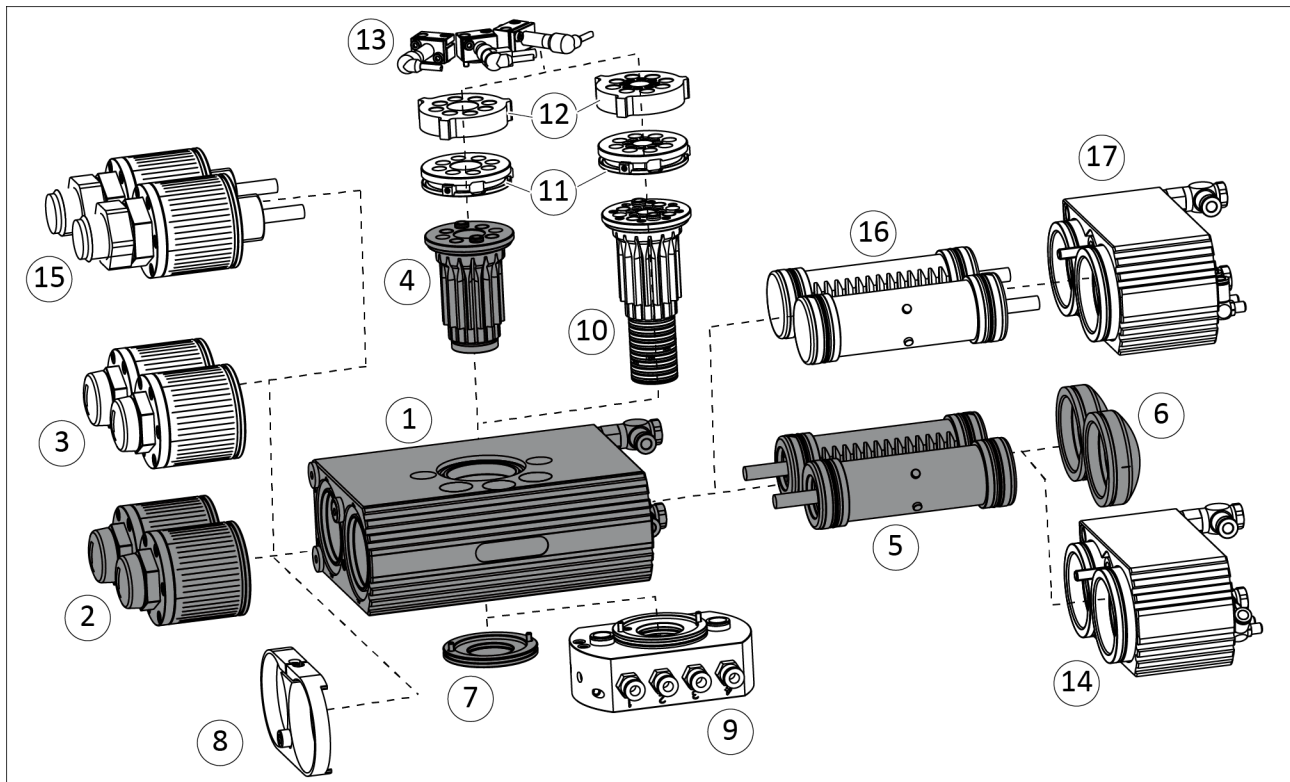

Design

| | | | |
|---|-------------------------------|----|--|
| 1 | Housing | 10 | Pinion for fluid feed-through |
| 2 | Back stops (0° - 180°) | 11 | Monitoring with movable cam |
| 3 | Back stops (0° - 90°) | 12 | Monitoring with fixed cam |
| 4 | Pinion | 13 | Sensor holder with sensor |
| 5 | Piston with shock absorbers | 14 | Attaching center position (0°-90°-180°) |
| 6 | Cover | 15 | Back stops locked center position |
| 7 | Cover | 16 | Pistions with shock absorbers locked center position |
| 8 | Clamp shells* | 17 | Attaching locked center position (0°-90°-180°) |
| 9 | Flange for fluid feed-through | | |

* The variant "explosion-protected version" does not contain a clamp shell. It is clamped by an eccentric.

4.1.1 Variant with electrical feed-through (EDF)

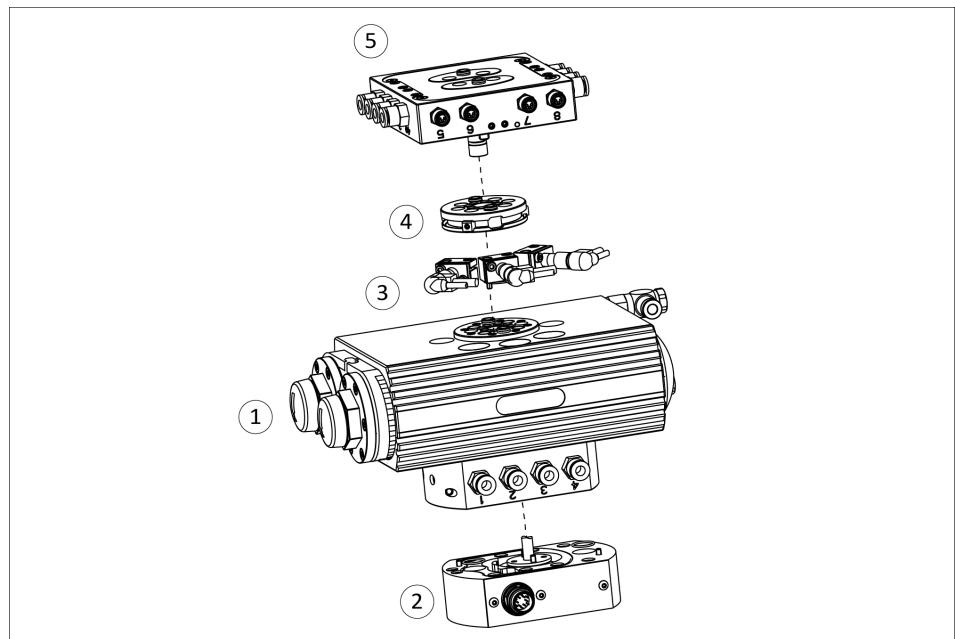

Assembly with EDF

| | |
|---|-----------------------------------|
| 1 | Base unit with fluid feed-through |
| 2 | EDF flange |
| 3 | Sensor holder with sensor |
| 4 | Monitoring with fixed cam |
| 5 | Distributor plate |

4.2 Description

The product is a pneumatic rotary actuator for rotating and swiveling movements.

Variant angle of rotation

With the angle of rotation variant, an angle of rotation of 90° or 180° can be set.

End position adjustability variant

With the end position adjustability variant, the end positions can be adjusted from +3°/-3° or +3°/90°.

Variant center position (M), locked center position (VM)

The center position variant allows you to switch between pneumatic and locked. The locked center position can be unlocked when loaded.

Fluid feed-through (MDF) variant

With the fluid feed-through variant, gasses, fluids and vacuums can be fed through without hoses.

Electrical feed-through (EDF) variant

With the electrical feed-through (EDF) variant, signals for supplying the product can be carried out with operational safety.

5 Assembly

5.1 Assembling and connecting



⚠ WARNING

Risk of injury due to unexpected movement of the machine/system!

With a horizontal swiveling axis, secure locking is not guaranteed during the ventilation stage when a swivelling movement is being performed from 3 o'clock (180°) to 6 o'clock (90°) or from 9 o'clock (0°) to 6 o'clock (90°).

- Screw the separating sleeves into air connections "A" and "B".
- Control both piston chambers of the "A" and "B" air connections separately for the purpose of holding torque.

CAUTION

Risk of damage to the product!

If the end position is approached too hard, the product may be damaged.

- As a rule, a rotary movement must take place without impact and bouncing.
- To do this, carry out sufficient throttle and dampening.
- Observe specifications in the catalog data sheet.

CAUTION

Risk of damage to the product!

If during first actuation the exhaust throttle valves are open, the product may move in an uncontrolled manner.

- Before actuation, check that the exhaust throttle valves are closed and if necessary close any open ones completely.

- Screw on rotary actuator, [Mechanical connection](#) [▶ 26].
 - ✓ Use centering sleeves.
 - ✓ Observe the tightening torque for the mounting screws, see tightening torque table.
- Screw attachment on the pinion with two fitting screws and two mounting screws, [Mechanical connection](#) [▶ 26].
- In air connections "A" and "B", screw in throttle valves and connect compressed air lines.
Or with hose-free direct connection:
Screw locking screws into air connections "A" and "B", [Pneumatic connection](#) [▶ 31].
Mount throttle valves in the supply lines "a" and "b".
- Screw in locking screws in open and not required air connections where appropriate.
- With the variant with electrical feed-through (EDF), connect connection cable, [Electrical connection](#) [▶ 33].
- For application cases with horizontal swivel axes, mount separating sleeves, [Mounting separating sleeve](#) [▶ 35].
- Adjust angle of rotation, [Adjust swivel angle](#) [▶ 38].
- Adjust swiveling speed, [Adjust swiveling speed](#) [▶ 40].
- Adjust absorber stroke, [Adjust absorber stroke](#) [▶ 41].
- Mount sensor if necessary, [Installing the sensors](#) [▶ 45].

5.2 Connections

5.2.1 Mechanical connection



⚠ DANGER

Danger of explosion in potentially explosive areas!

- Observe supplementary sheet for products with explosion-resistant versions "SRU-plus -...-EX".

NOTE

Adapter plates between the product and the machine/system as well as the product and the attachment part must be made of high-strength aluminum or steel. The tolerance class for the fitting bore is H7.

Connections on housing

The product can be assembled from two sides.

- On the attachment side via through-bores
- On the side of the apparatus via threaded holes

Centering sleeves for the mounting screws are included in the accessory pack.

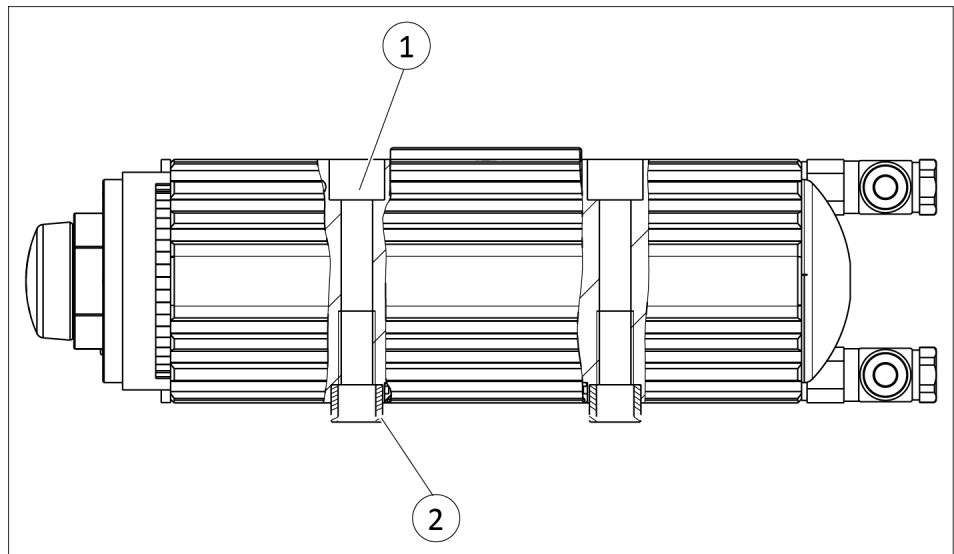

Assembly options

| Item | Mounting | SRU-plus | | | | | | |
|------|---|----------|-----|-----|-----|-----|-----|-----|
| | | 20 | 25 | 30 | 35 | 40 | 50 | 60 |
| 1 | Mounting screw | M8 | M8 | M8 | M8 | M10 | M12 | M12 |
| | Max. depth of engagement from locating surface [mm] | 24 | 24 | 24 | 24 | 25 | 25 | 25 |
| 2 | Centering sleeve | Ø12 | Ø12 | Ø12 | Ø12 | Ø14 | Ø16 | Ø16 |

Attachment connections without fluid feed-through

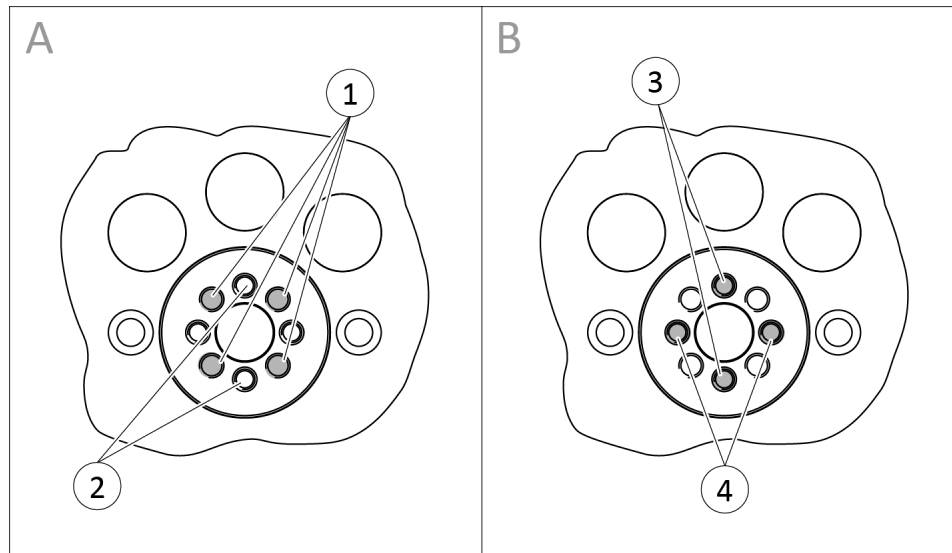

Attachment connection without fluid feed-through

| | | | |
|---|-----------------------------------|---|---|
| A | Screw connection diagram SRU-plus | B | Screw connection diagram SRU-plus compatible with OSE |
|---|-----------------------------------|---|---|

| Item | Designation | SRU-plus | | | | | | |
|------|---|----------|----|----|----|----|-----|-----|
| | | 20 | 25 | 30 | 35 | 40 | 50 | 60 |
| 1 | Threads for mounting screws | M5 | M6 | M6 | M6 | M8 | M10 | M10 |
| | Max. depth of engagement from locating surface [mm] | 9 | 10 | 9 | 10 | 9 | 15 | 15 |
| 2 | Centering sleeve | ∅6 | ∅6 | ∅6 | ∅6 | ∅8 | ∅10 | ∅10 |
| 3 | Threads for mounting screws | M5 | M6 | M6 | M6 | M6 | M8 | M8 |
| | Max. depth of engagement from locating surface [mm] | 9 | 9 | 9 | 9 | 11 | 13 | 13 |
| 4 | Threads for dowel screws | M5 | M5 | M5 | M5 | M6 | M8 | M8 |
| | Max. depth of engagement from locating surface [mm] | 10 | 10 | 10 | 10 | 11 | 17 | 20 |

Attachment connections with fluid feed-through

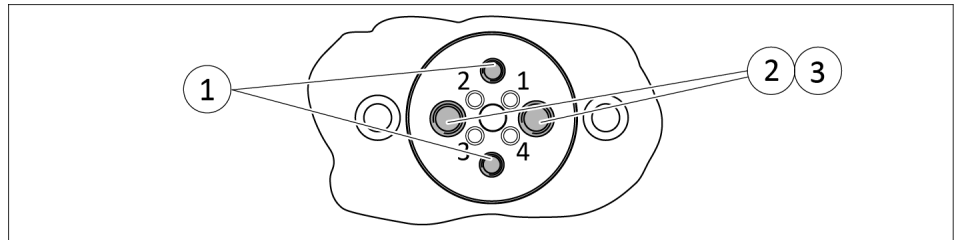

Attachment connection with fluid feed-through up to size 30, example size 25

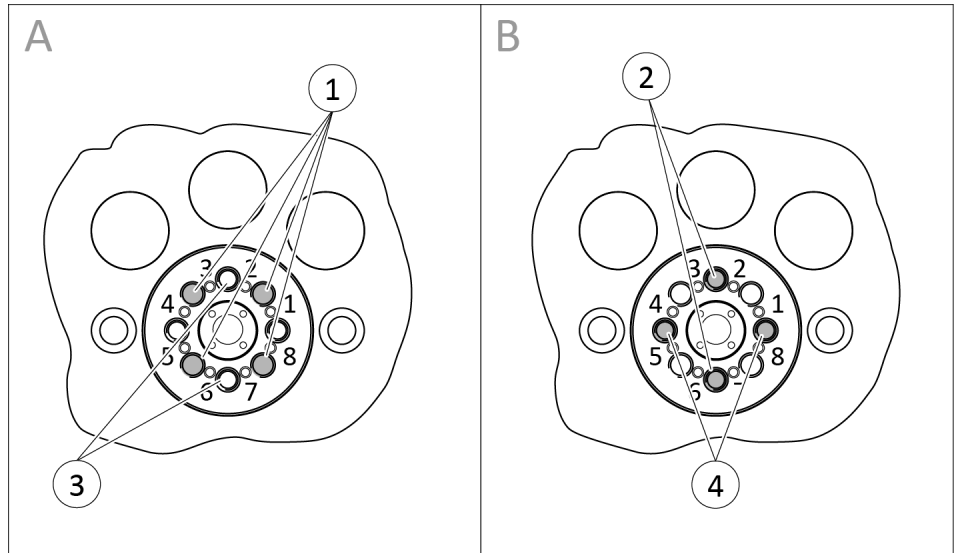

Attachment connection with fluid feed-through from size 35, example size 50

| | | | |
|---|-----------------------------------|---|--|
| A | Screw connection diagram SRU-plus | B | Screw connection diagram SRU-plus, compatible with OSE |
|---|-----------------------------------|---|--|

| Item | Designation | SRU-plus | | | | | | |
|------|---|----------|----|----|----|----|-----|-----|
| | | 20 | 25 | 30 | 35 | 40 | 50 | 60 |
| 1 | Threads for mounting screws | M5 | M5 | M5 | M6 | M8 | M10 | M10 |
| | Max. depth of engagement from locating surface [mm] | 9 | 9 | 9 | 10 | 9 | 15 | 15 |
| 2 | Threads for mounting screws | M5 | M5 | M5 | M5 | M6 | M8 | M8 |
| | Max. depth of engagement from locating surface [mm] | 9.5 | 9 | 9 | 9 | 11 | 13 | 13 |
| 3 | Centering sleeve | Ø8 | Ø8 | Ø8 | Ø6 | Ø8 | Ø10 | Ø10 |
| 4 | Threads for dowel screws | – | – | – | M5 | M6 | M8 | M8 |
| | Max. depth of engagement from locating surface [mm] | – | – | – | 10 | 11 | 20 | 20 |

5.2.1.1 Variant with electrical feed-through (EDF)

For the variant with electrical feed-through (EDF), it can only be assembled on the system side via the threaded hole.

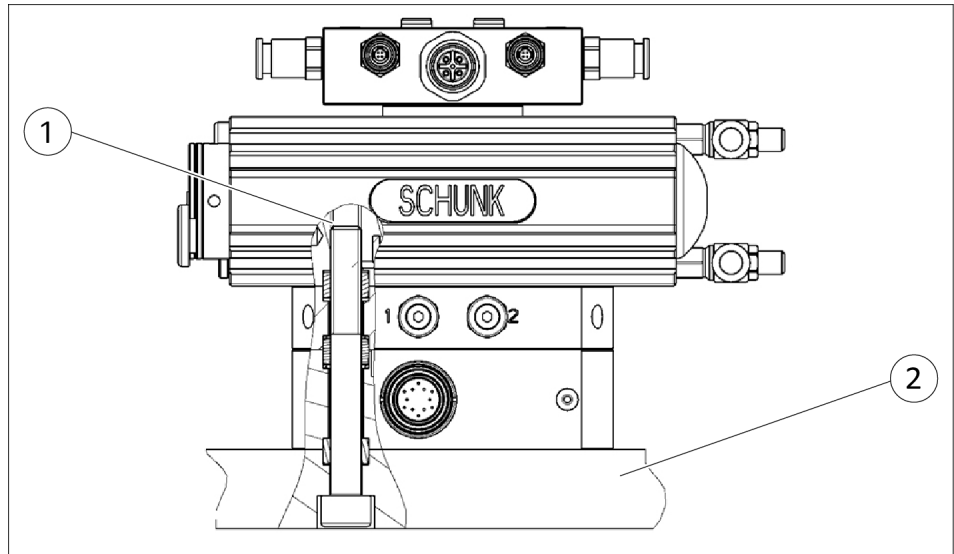

Assembly options

| | | | |
|---|--|---|--------------------------|
| 1 | Threaded holes assembly on the system side | 2 | Customer's adapter plate |
|---|--|---|--------------------------|

Attachment connection

If the hose-free direct connection is used, the set-screws must be removed.

With the variant with electrical feed-through (EDF), assembly of the attachment with fitting screws is not possible.

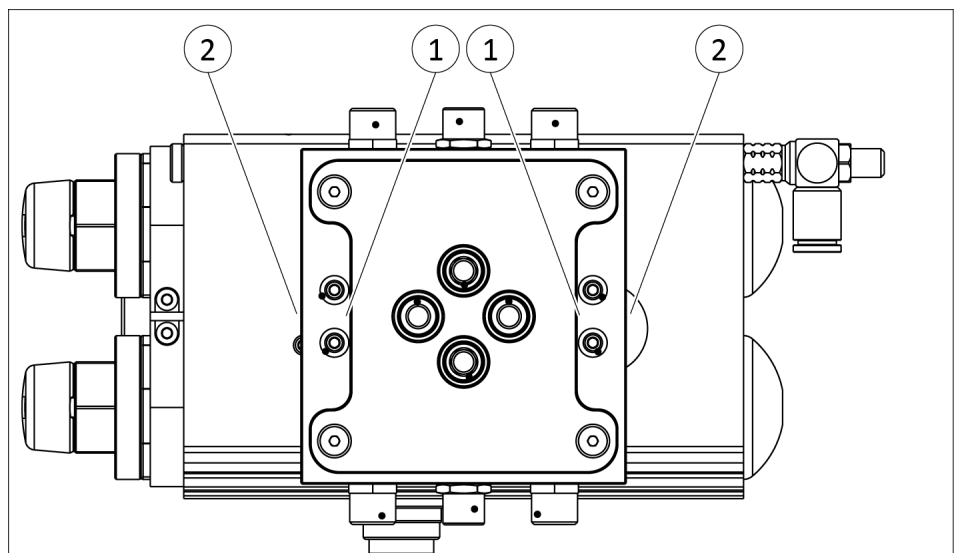

Attachment connection

| | | | |
|---|-----------|---|---------------------|
| 1 | Set-screw | 2 | Side air connection |
|---|-----------|---|---------------------|

5.2.2 Pneumatic connection



⚠ DANGER

Danger of explosion in potentially explosive areas!

- Observe supplementary sheet for products with explosion-resistant versions "SRU-plus -...-EX".

NOTE

- Observe the requirements for the compressed air supply, [Technical data](#) [▶ 19].
- In case of compressed air loss (cutting off the energy line), the components lose their dynamic effects and do not remain in a secure position. However, the use of a SDV-P pressure maintenance valve is recommended in this case in order to maintain the dynamic effect for some time. Product variants are also offered with mechanical gripping force via springs, which also ensure a minimum clamping force in the event of a pressure drop.

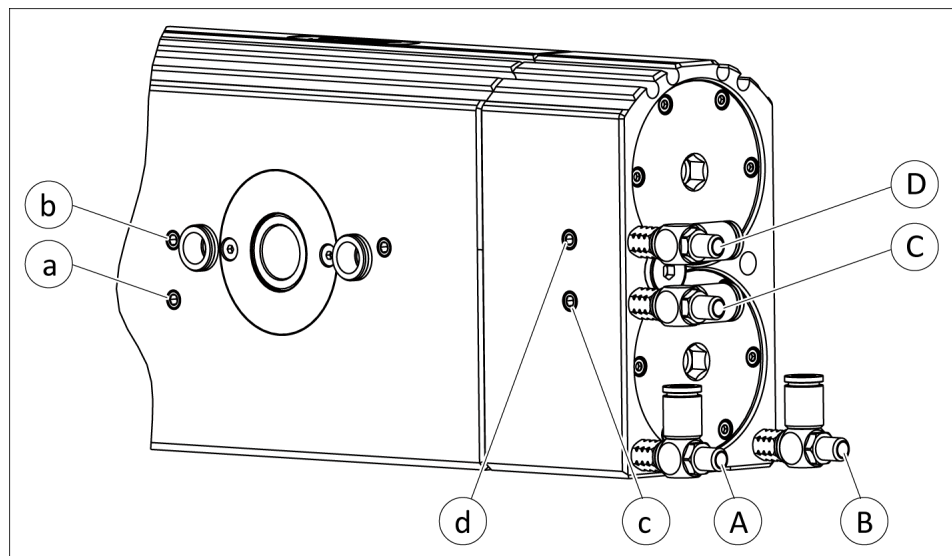

Air connections, variant with center position

| Designation | Function |
|-----------------------------|--------------------------------|
| Hose-free direct connection | |
| a | Swiveling 0° -90° / 0° - 180° |
| b | Swiveling 90° - 0° / 180° - 0° |
| c | Approach center position (M) |
| d | Extend locking position (VM) |
| Hose connection | |
| A | Swiveling 0° -90° / 0° - 180° |
| B | Swiveling 90° - 0° / 180° - 0° |
| C | Approach center position (M) |
| D | Extend locking position (VM) |

- Only open the air connections required.
- Seal those main air connections that are not needed using the locking screws from the accessory pack.
- For hose-free direct connections, use the O-rings from the accessory pack.
- Use throttle valve from the accessory pack for the main air connections.
- With hose-free direct connections, throttle valves must be fitted in front of the main air connections.

Pay attention to the following table when using throttle valves.

| Variant | Air connection | | | |
|---|----------------------|-------------------------|----------------------|-------------------------|
| | A | B | C | D |
| Without center position | Exhaust | Exhaust | - | - |
| With center position (M) | Exhaust | Exhaust | Supply air | Supply air |
| With locked center position (VM) | Supply air | Supply air | Supply air | Supply air |
| With locked center position (VM) and separate piston chambers | A1 Exhaust | A2 Supply air | B1 Exhaust | B2 Supply air |

Variant with center position (M)

For the pneumatic center position, the air connections *C* and *D* must be actuated together with a branching.

Variant with locked center position (VM)

If supply air throttle valves are used with the locked center position on the air connections *C* and *D*, the locking is engaged smoothly. The operating pressure for the lock must be between 4 and 6 bar. If exhaust throttle valves are used on the variant with locked center position, this can cause malfunctions.

Variant with fluid feed-through

The connections marked with numbers on the pinion and the flange are provided for feed-through of vacuum, gasses or fluids.

5.2.3 Electrical connection

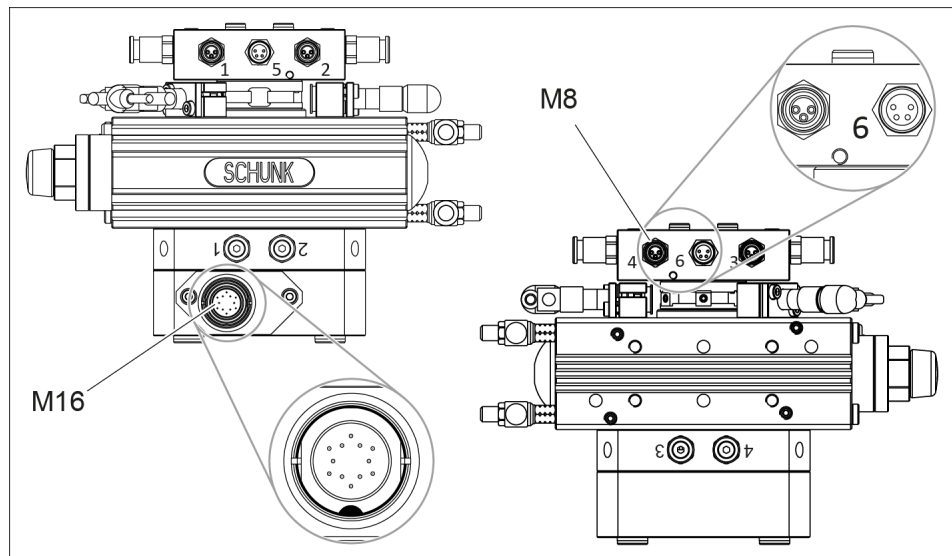

SRU-plus 20-35 with EDF, for example SRU-plus 30 with M8 socket

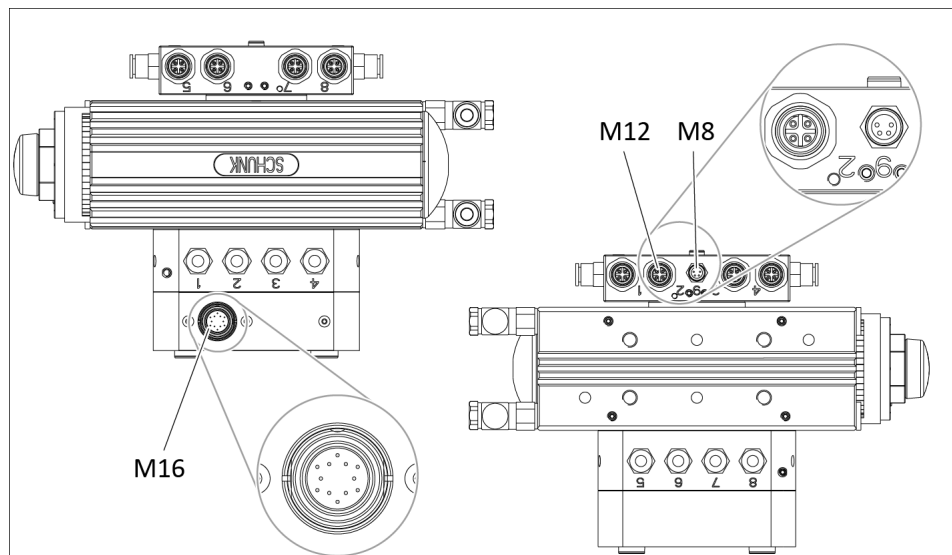

SRU-plus 40-60 with EDF, for example SRU-plus 40 with M8 socket and M12 socket

Bending radius

Minimum bending radius for constant movement: 10 x cable diameter

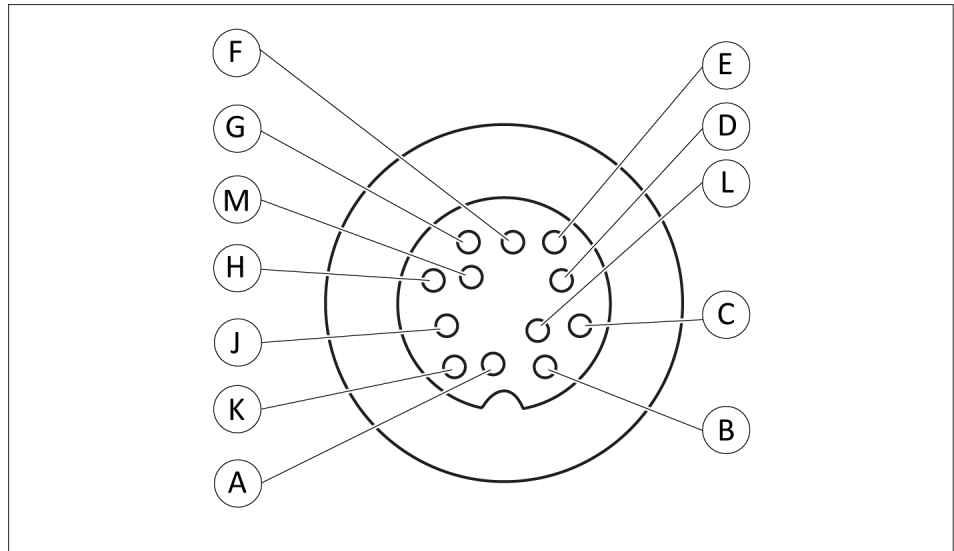

Pin allocation, connection plug M16

| Pin | Pin allocation SRU-plus | |
|--------|------------------------------|------------------------------|
| | 20-35 EDF | 40-60 EDF |
| A | Switching signal, sensor 3 | Switching signal, sensor 3 |
| B | GND (common) | GND (common) |
| C | Switching signal, sensor 2 | Switching signal, sensor 2 |
| D | Switching signal, sensor 4 | Switching signal, sensor 4 |
| E | Switching signal, sensor 1 | Switching signal, sensor 1 |
| F | Switching signal 1, sensor 5 | Switching signal, sensor 5 |
| G | Switching signal 2, sensor 5 | Switching signal, sensor 6 |
| H | +24 V (common) | +24 V (common) |
| J | Switching signal 1, sensor 6 | Switching signal, sensor 7 |
| K | Switching signal 2, sensor 6 | Switching signal 1, sensor 9 |
| L | - not connected - | Switching signal 2, sensor 9 |
| M | - not connected - | Switching signal, sensor 8 |
| Shield | SHD | SHD |

5.3 Mounting separating sleeve

CAUTION

The O-ring could be damaged!

If the set-screw is turned too far into the air connection, the O-ring may be damaged when screwing in the separating sleeve and the air connection may not be sealed tightly.

- Screw set-screw out to a small extent.
- Screw the separating sleeve carefully until the end of the threads.

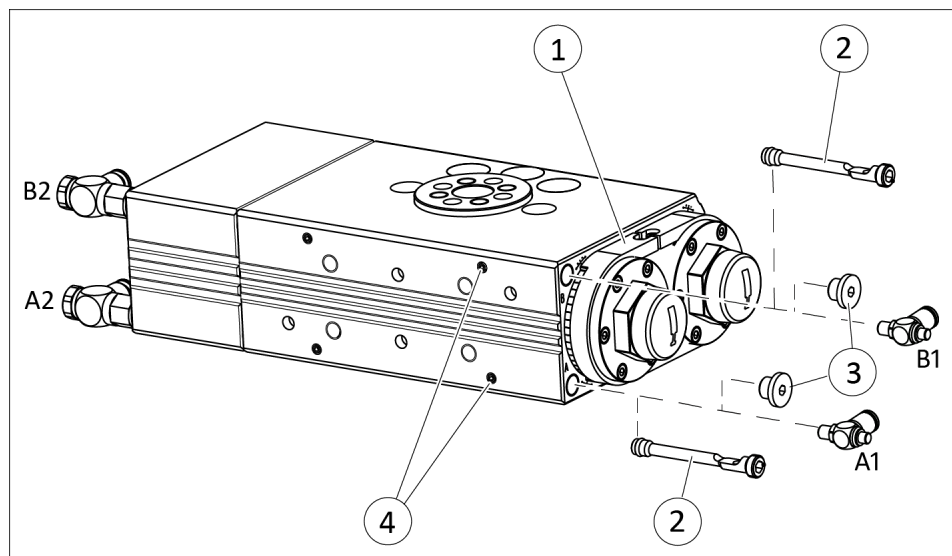

- Screw the locking screws (3) on the apparatus side (1) out of the air connections A and B.
- Screw set-screws (4) out to a small extent.
- Screw separating sleeves (2) from the accessory pack into the air connections A and B until the end of the threads.
- Screw in unscrewed set-screws (4) until the separating sleeve.
- Mount hose connections A1, A2, B1 and B2.
 - ✓ Position the hose connections, [Pneumatic connection](#) [▶ 31].

5.4 Settings

CAUTION

Risk of damage to the product!

If the end position is approached too hard, the product may be damaged.

- Adjust exhaust throttle valve and shock absorber so that the movement is braked smoothly.

For operation, the angle of rotation, the swiveling speed and the absorber stroke must be set. For variants with pneumatic or locked center position, the center position must be set as well.

Settings must always be made under the later operating conditions. If the operating conditions change, e.g., weight of the workpiece, check that the movement is braked smoothly. If necessary, readjust rotating angle, swiveling speed, absorber stroke and center position.

Angle of rotation

The angle of rotation is set in order to achieve a fine adjustment of the end positions.

The end positions can be adjusted by $\pm 3^\circ$ or $+3^\circ/-90^\circ$ depending on the variant. If the end positions are adjusted, the swiveling speed and absorber stroke might also have to be readjusted.

Swiveling speed and absorber stroke

Swiveling speed and absorber stroke are set in order to ensure a smooth operating cycle for the operating conditions, as both settings are dependent on each other.

Each end position is set separately. The position of exhaust throttle valve and shock absorber may deviate from one another.

Center position

The center position can be adjusted by $\pm 3^\circ$. If the center position is adjusted, the angle of rotation, swiveling speed and absorber stroke might also have to be readjusted.

Optimal setting

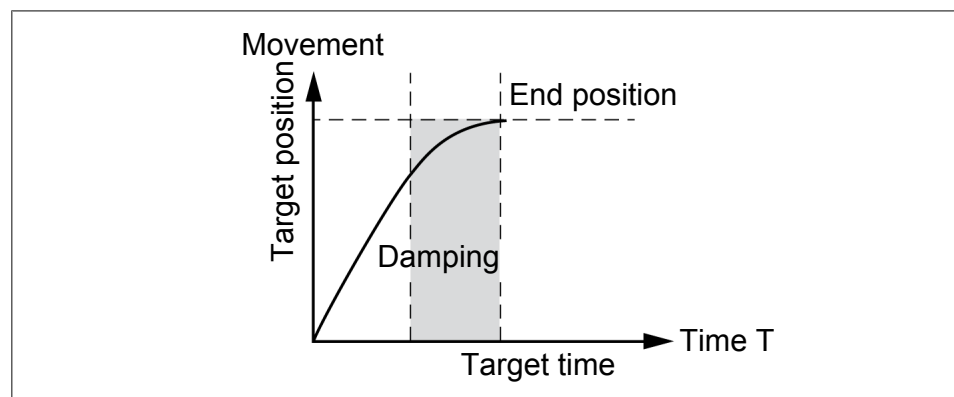

Swiveling speed and absorber stroke are optimal.

Erroneous setting

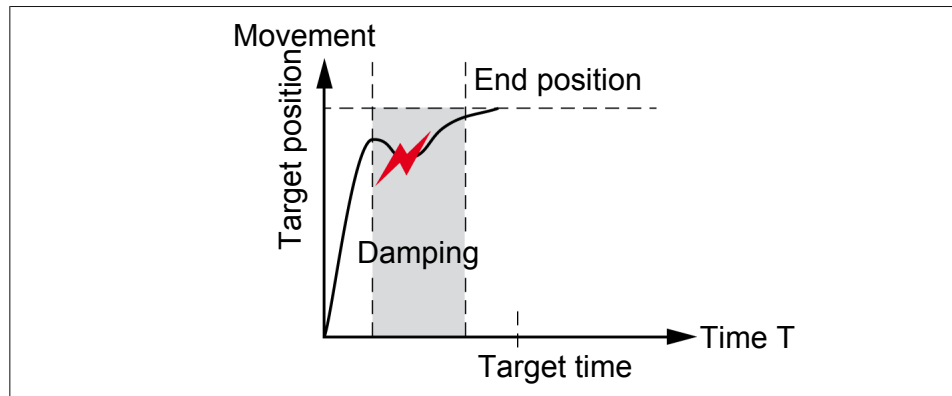

Swiveling speed too high. Assembly oscillates back.

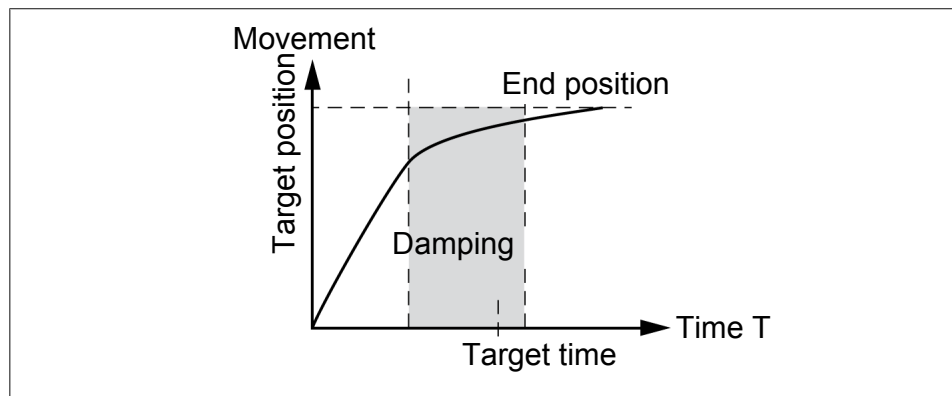

Absorber stroke is too long. End position is reached too slowly.

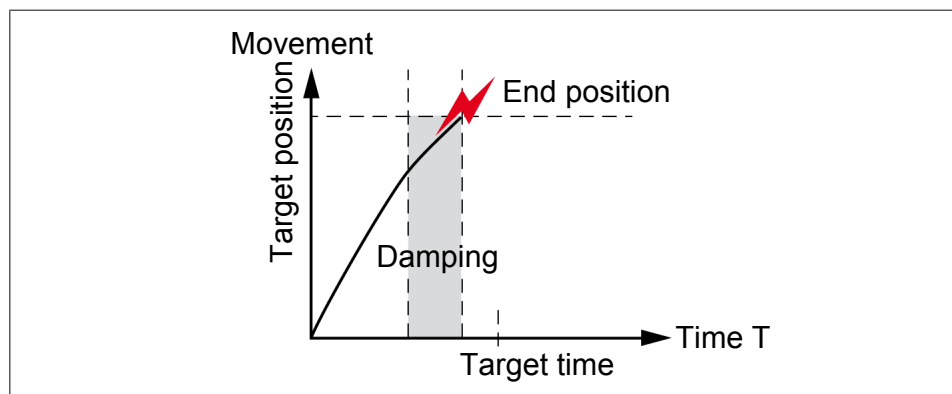

Absorber stroke is too short. Assembly hits the end position.

5.4.1 Adjust swivel angle

CAUTION

Material damage due to incorrect settings!

By incorrect setting of the swivel angle parts can come loose and the product may be damaged.

- Only trained staff may set the swivel angle.
- Before setting the swivel angle release pressure.

Version with clamp shell

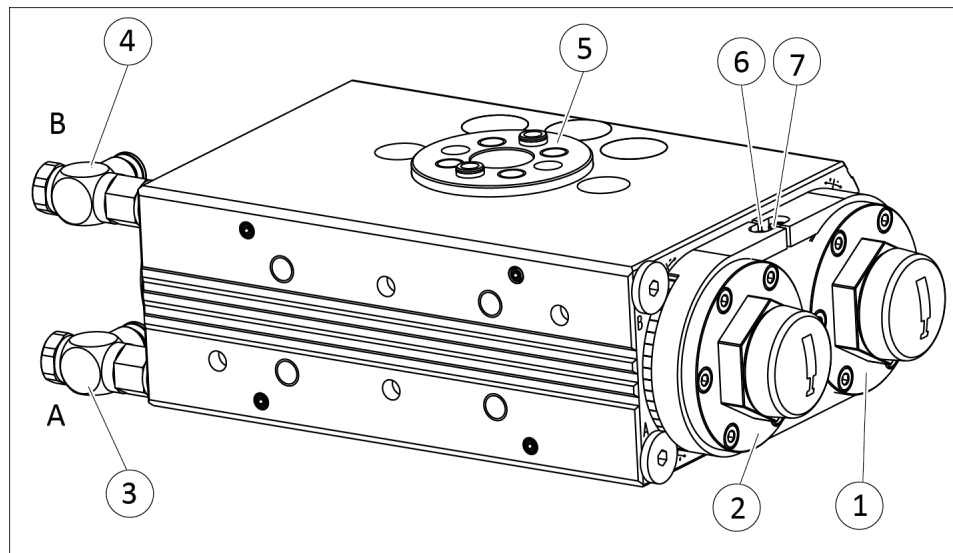

- Loosen screw of the limiting sleeve (6) approx. one revolution.
- Actuate air connection B (4).
- Open exhaust throttle valve on air connection A (3) until the pinion (5) starts to move.
 - ✓ Pinion swivels towards the end position.
- Set the desired end position by twisting the stop B (2).
- Check end position.
 - ✓ To do this, ventilate air connection B (4) and actuate it again, if necessary adjust end position.
- Tighten screw (6).
- Loosen screw of the limiting sleeve (7) approx. one revolution.
- Ventilate air connection B (4) and actuate air connection A (3).
- Open exhaust throttle valve on air connection B (4) until the pinion (5) starts to move.
 - ✓ Pinion swivels towards the end position.
- Set the desired end position by twisting the stop A (1).
- Check end position.
 - ✓ To do this, ventilate air connection A (3) and actuate it again, if necessary adjust end position.
- Tighten screw (7).
 - ✓ Tightening torque:SRU-plus 20-30: 1.2 Nm / SRU-plus 35-50: 2.1 Nm
- Swivel repeatedly to test the setting, adjust if necessary.

Version with limiting sleeves

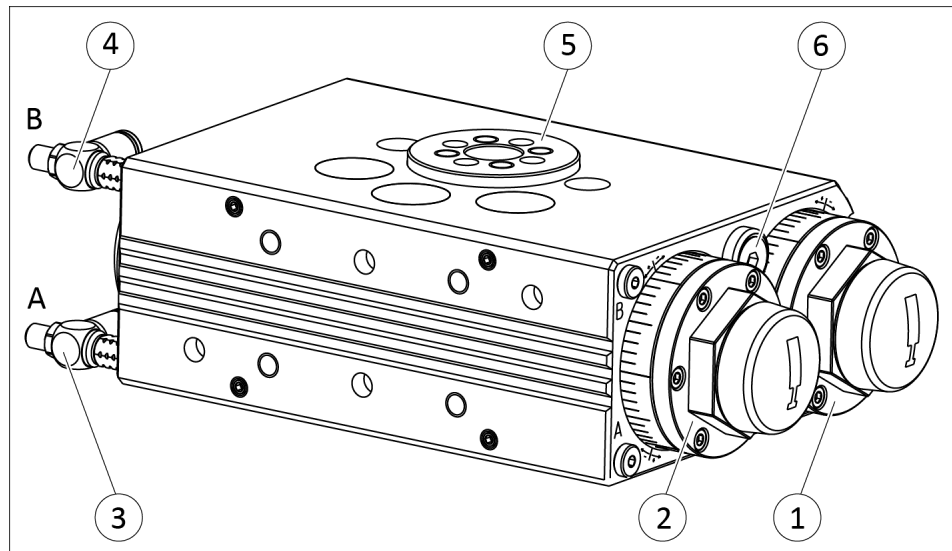

- Loosen screw of the limiting sleeve (6) approx. one revolution.
- Actuate air connection B (4).
- Open exhaust throttle valve on air connection A (3) until the pinion (5) starts to move.
 - ✓ Pinion swivels towards the end position.
- Set the desired end position by twisting the stop B (2).
- Check end position.
 - ✓ To do this, ventilate air connection B (4) and actuate it again, if necessary adjust end position.
- Ventilating air connection B (4) and actuating air connection A (3).
- Open exhaust throttle valve on air connection B (4) until the pinion (5) starts to move.
 - ✓ Pinion swivels towards the end position.
- Set the desired end position by twisting the stop A (1).
- Check end position.
 - ✓ To do this, ventilate air connection A (3) and actuate it again, if necessary adjust end position.
- Tighten screw (6).
 - ✓ Tightening torque:SRU-plus 20-40: 10 Nm / SRU-plus 50-60: 24 Nm
- Swivel repeatedly to test the setting, adjust if necessary.

5.4.2 Adjust swiveling speed

CAUTION

Material damage due to too high swiveling speed!

If the swiveling speed is too high, the assembly will be decelerated abruptly by the shock absorber and will continue to oscillate until reaching the end position. This will overload the shock absorber and may cause damage to it.

- Adjust the swiveling speed in a way, that the movement decelerate smoothly in the end position.

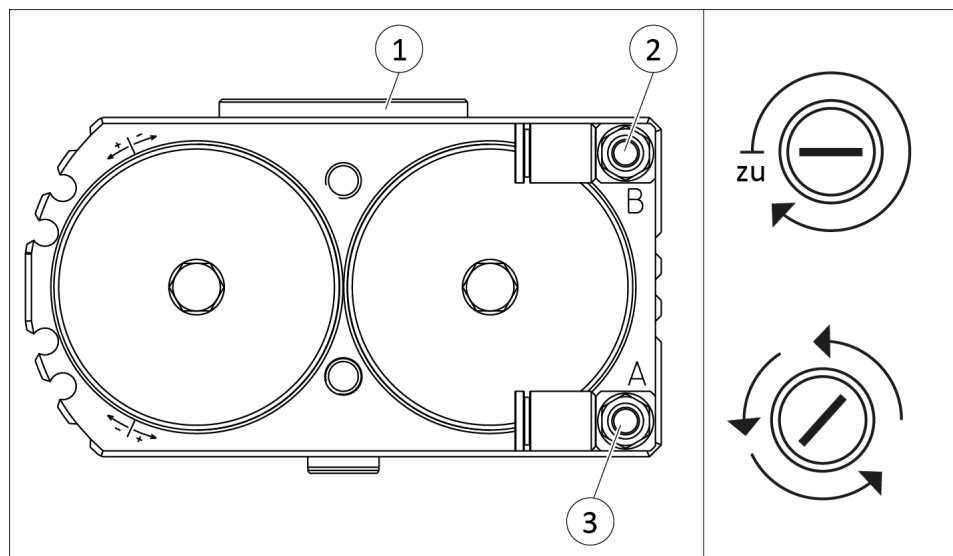

- Close both exhaust throttle valves completely.
- **At the air connection A (3):**
- Actuate air connection A (3).
- Open exhaust throttle valve until the pinion (1) starts to move.
 - ✓ Pinion swivels towards the end position.
- Continue to open the exhaust throttle valve incrementally until the movement brakes smoothly.
- If the swivel speed is too high, the exhaust throttle valve must be closed again incrementally, until the optimal swivel time is reached.
- Swivel repeatedly to test the setting, readjust if necessary.
- **On the air connection B (2):**
Repeat the steps for the other end position.

NOTE

Further setting of the movement is carried out via the absorber stroke, [Adjust absorber stroke](#) [▶ 41].

For the variants with pneumatic and locked center position, air supply throttle valves must be mounted to various air connections, [Pneumatic connection](#) [► 31]. The sequence for setting the swivel speed with the air supply throttle valve is identical to the sequence with mounted exhaust throttle valve.

In addition to air connections *A* and *B* the air connections *C* and *D* must also be set for the variants with pneumatic and locked center position.

For the variant with locked center position and separate piston chambers, the air connections *A1*, *A2*, *B1* and *B2* must be set.

5.4.3 Adjust absorber stroke

CAUTION

Material damage to the product possible!

If the maximum adjustment range of the absorber stroke is exceeded, this can cause leaks in the product.

- When setting the absorber stroke, adhere to the maximum adjustment range.

| Designation | SRU-plus | | | | | | |
|----------------------------|----------|-----|-----|-----|-----|------|------|
| | 20 | 25 | 30 | 35 | 40 | 50 | 60 |
| Max. adjustment range [mm] | 7.5 | 7.5 | 7.5 | 6.5 | 6.5 | 10.5 | 10.5 |

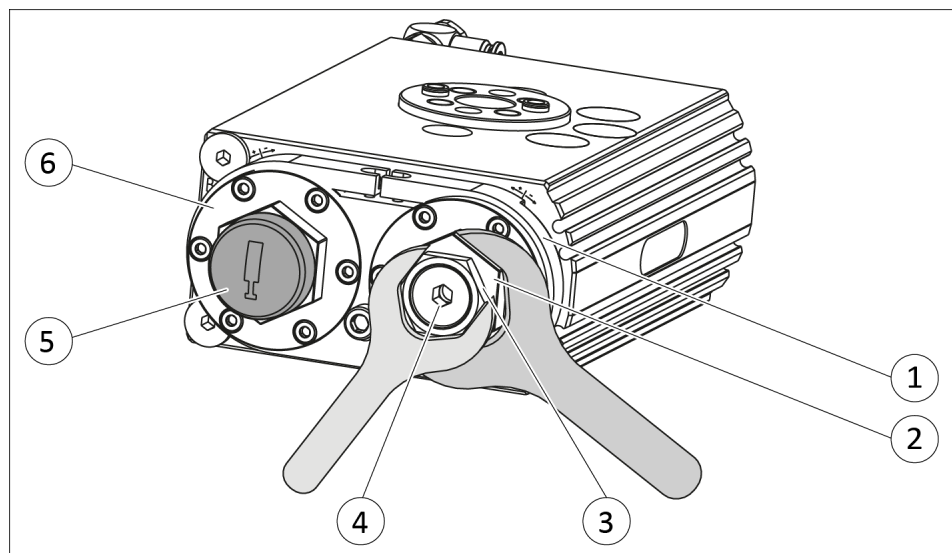

- Check deceleration of the movement in the end positions.
 - ✓ If the absorber stroke is too long, the end position is reached too slowly.
 - ✓ If the absorber stroke is too short, the assembly impacts in the end position.

- **On the first shock absorber (1):**
 - remove cover (5).
- Fix back stop A (2) and loosen nut (3) on stop pin A (4).
- Fix back stop A (2) and set stop pin A (4).

NOTE

If the absorber stroke is changed, the swivel speed might also need to be changed as well, so that the movement remains smooth, [Adjust swiveling speed](#) [▶ 40].

- ✓ **IMPORTANT! If the stop pin is unscrewed too far, this may cause the rotary actuator to leak.**
 - By unscrewing stop pin A (4), the absorber stroke is reduced.
- ✓ By screwing in stop pin A (4), the absorber stroke is increased.
- Fix stop pin A (4) and tighten bolt (3).
- Fix back stop A (2) and tighten bolt (3).
- Swivel repeatedly to test the setting, set again if necessary.
 - ✓ The end positions must be approached gently.
- Put on cover cap (4).
- **On the second shock absorber (6)**
 - Repeat the steps for the other end position.

NOTE

Depending on the loading condition, the settings for the two shock absorbers may deviate widely from each other.

5.4.4 Set center position

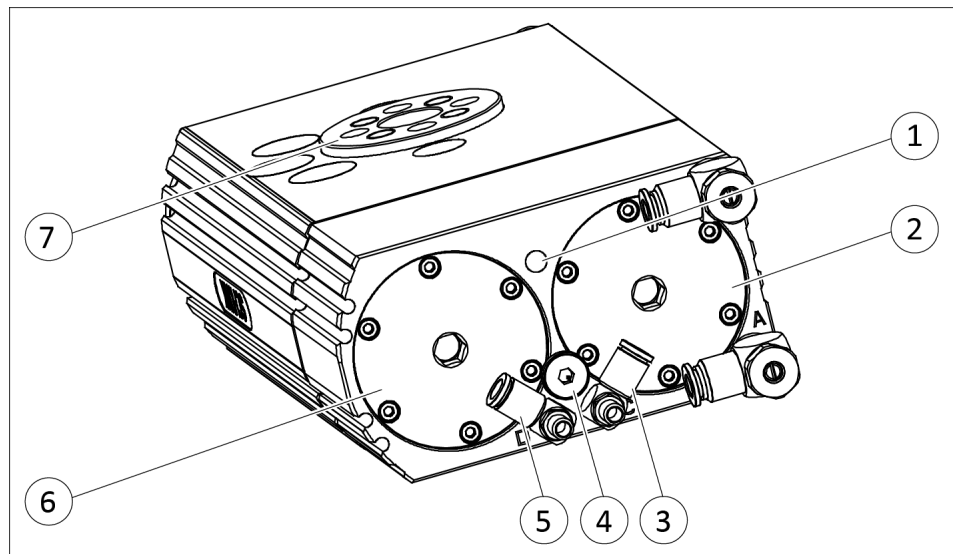

- Loosen screw (1) by approx. one revolution.
- Unscrew stops C (2) and D (6) to the limit sleeve (4).
- Actuate air connections C (3) and D (5) at the same time.
 - ✓ Rotary actuator swivels to about 90° and has about 6° of play in this position.
- Turn pinion (7) clockwise and press it against stop C (2).
- Turn stop C (2) to the required center position.
- Turn stop D (6) until the pinion (7) no longer has play in the center position.
- Tighten screw (1).
 - ✓ Tightening torque: 20-40: 10 Nm / 50-60: 24 Nm
- Swivel repeatedly to test the setting, set again if necessary.

5.4.5 Set locked center position

Depending on the start-up direction of stop A (11) or stop B (10), the center positions can be set the same or differently.

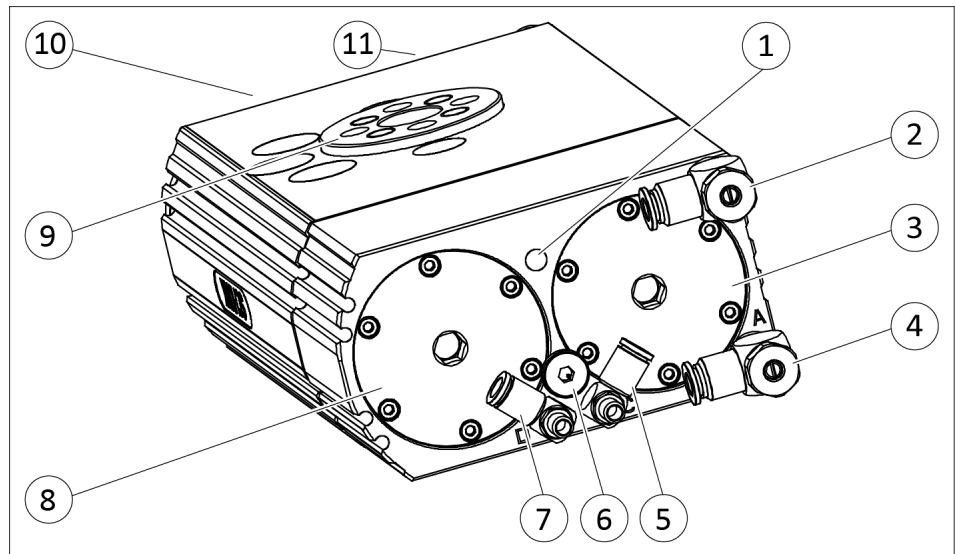

- Ventilate rotary actuator.
- Loosen screw (1) by approx. one revolution.
- Actuate air connection B (2).
 - ✓ Rotary actuator swivels to stop A (11).
- Ventilate air connection B (2) and actuate air connection C (5).
 - ✓ Stop C (3) locks.
- Actuate air connection A (4).
 - ✓ Rotary actuator swivels to stop C (3), basic setting 90°.
- Turn stop C (3) to the required center position.
- Ventilate air connection C (5).
 - ✓ Rotary actuator swivels to stop B (10).
- Ventilate air connection A (4) and actuate air connection D (7).
 - ✓ Stop D (8) locks.
- Actuate air connection B (2).
 - ✓ Rotary actuator swivels to stop D (8).
- Turn stop D (8) to the required center position.
- Tighten screw (1).
 - ✓ Tightening torque: 20-40: 10 Nm / 50-60: 24 Nm
- Swivel repeatedly to test the setting, set again if necessary, [Electrical circuit diagram actuation with two 5/3 directional control valves, example](#) [▶ 56].

5.5 Installing the sensors



⚠ DANGER

Danger of explosion in potentially explosive areas!

- Observe supplementary sheet for products with explosion-resistant versions "SRU-plus -...-EX".

NOTE

Observe the assembly and operating manual of the sensor for mounting and connecting.

The product is prepared for the use of sensors.

- For the exact type designations of suitable sensors, please see catalog datasheet and [Overview of sensors](#) [► 45].
- For technical data for the suitable sensors, see assembly and operating manual and catalog datasheet.
 - The assembly and operating manual and catalog datasheet are included in the scope of delivery for the sensors and are available at schunk.com.
- Information on handling sensors is available at schunk.com or from SCHUNK contact persons.

5.5.1 Overview of sensors

| Designation | SRU-plus | | | | | | |
|---|----------|----|----|----|----|----|----|
| | 20 | 25 | 30 | 35 | 40 | 50 | 60 |
| Magnetic switch MMS 22 | X | X | X | X | X | X | X |
| Programmable magnetic switch MMS 22-PI1 | X | X | X | X | X | X | X |
| Inductive proximity switch IN 80 | X | X | X | X | X | X | X |

5.5.2 Mounting MMS 22 magnetic switch

CAUTION

Material damage due to an incorrect tightening torque!

If the threaded pin is tightened with an incorrect tightening torque, the product may be damaged.

- Observe a maximum tightening torque of 10 Ncm for the set-screws.

The sensors can be mounted via four grooves in the housing of the product.

We recommend the use of four magnetic switches to monitor the center position:

- Monitoring the end position *A*
- Monitoring the end position *B*
- Monitoring for the approach to the center position from end position *A*
- Monitoring for the approach to the center position from end position *B*

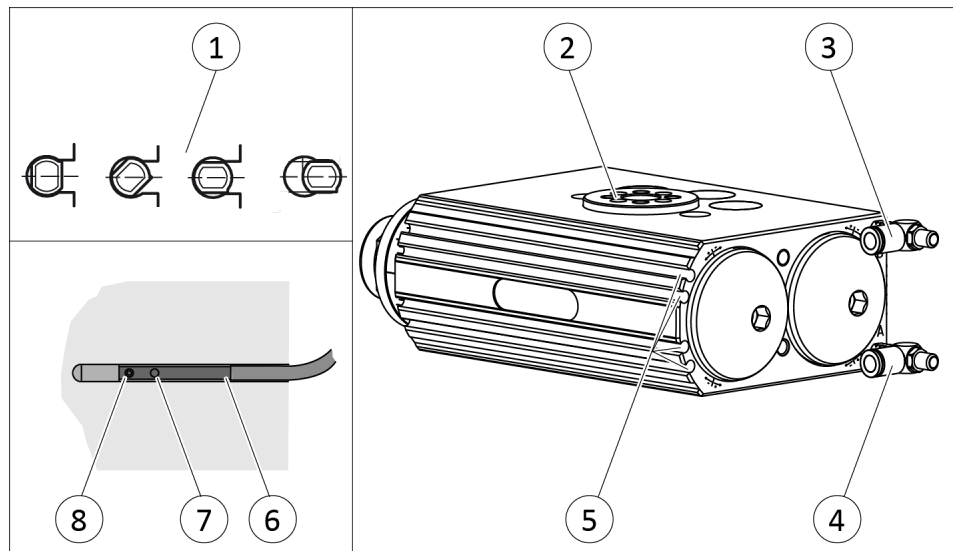

- Connect magnetic switch and secure cable, see sensor assembly and operating manual.
 - Actuate air connection A (4).
 - ✓ Pinion (2) swivels towards the end position.
 - Slide the first magnetic switch (6) into a groove (5).
Or: Screw magnetic switch (6) into a groove (5) (1).
 - Slide magnetic switch (6) until it switches and the LED (7) illuminates.
 - Tighten set screw (8).
 - ✓ Tightening torque: 10 Nm
 - Ventilate air connection A (4).
 - Actuate air connection B (3).
 - ✓ Pinion (2) swivels into the other end position.
 - Slide the second magnetic switch (6) into the other groove (5).
Or: Screw magnetic switch (6) into the other groove (5) (1).
 - Slide magnetic switch (6) until it switches and the LED (7) illuminates.
 - Tighten set screw (8).
 - ✓ Tightening torque: 10 Nm
 - Check switching positions, set again if necessary.
- Rotate unit in the center position and mount sensor analogously.

Center position variant

5.5.3 Mounting MMS 22-PI1 magnetic switch

CAUTION

Material damage due to an incorrect tightening torque!

If the threaded pin is tightened with an incorrect tightening torque, the product may be damaged.

- Observe a maximum tightening torque of 10 Ncm for the set-screws.

The sensors can be mounted via four grooves in the housing of the product.

We recommend the use of four magnetic switches to monitor the center position:

- Monitoring the end position *A*
- Monitoring the end position *B*
- Monitoring for the approach to the center position from end position *A*
- Monitoring for the approach to the center position from end position *B*

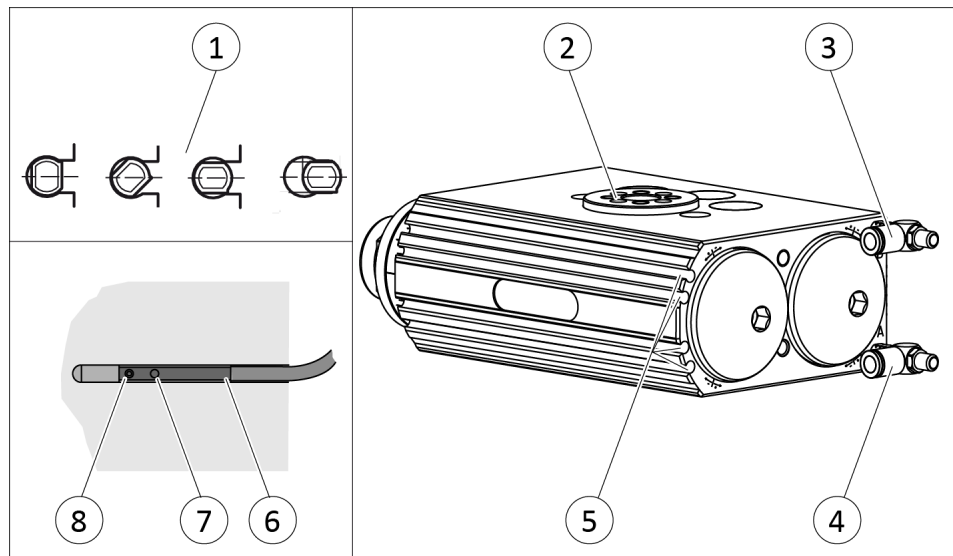

- Connect magnetic switch and secure cable, see sensor assembly and operating manual.
 - Actuate air connection A (4).
 - ✓ Pinion (2) swivels towards the end position.
 - Slide the first magnetic switch (6) into a groove (5).
Or: Screw magnetic switch (6) into a groove (5) (1).
 - Adjust magnetic switch (6), see Sensor Assembly and Operating Manual.
 - Tighten set screw (8).
 - ✓ Tightening torque: 10 Nm
 - Ventilate air connection A (4).
 - Actuate air connection B (3).
 - ✓ Pinion (2) swivels in the other end position.
 - Slide the second magnetic switch (6) into the other groove (5).
Or: Screw magnetic switch (6) into the other groove (5).
 - Adjust magnetic switch (6), see Sensor Assembly and Operating Manual.
 - Tighten set screw (8).
 - ✓ Tightening torque: 10 Nm
 - Check switching positions, set again if necessary.
- Rotate unit in the center position and mount sensor analogously.

Center position variant

5.5.4 Mounting inductive proximity switch IN 80

CAUTION

Material damage to the product or sensor possible!

If the fast clamping sleeve is inserted too far into the sensor bracket, the switch cam and the sensor may collide during swiveling.

- Do not insert the fast clamping sleeve too far into the sensor bracket.
- Pay attention to the distance between fast clamping sleeve and switch cam.

The proximity switches can be secured in three different positions:

- End position *A* (11)
- Center position (10)
- End position *B* (9)

The following assembly steps are the same for all three mounting positions:

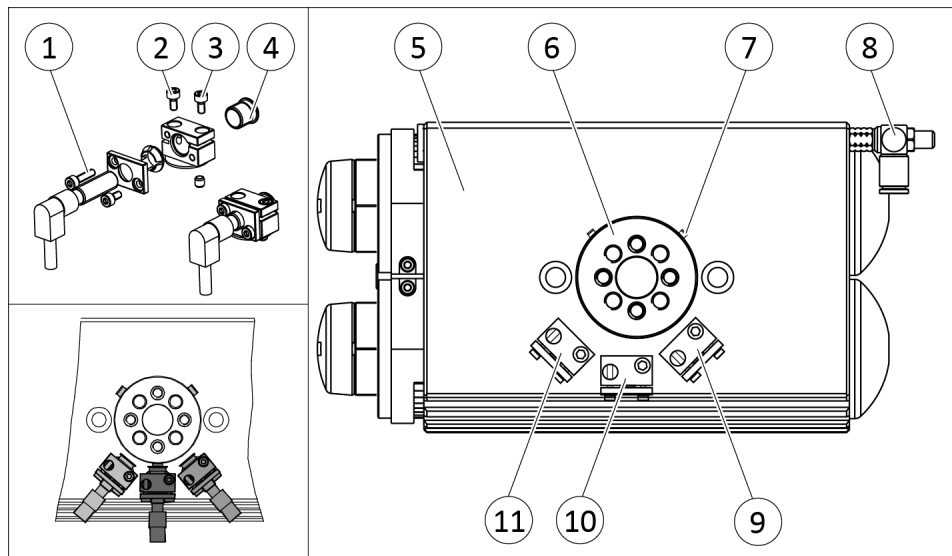

- Screw cam disk (6) onto pinion.
 - ✓ Use centering sleeves from the enclosed accessory kit.
 - ✓ Place seal from the accessory kit between cam disk (6) and pinion.

IMPORTANT! For the variant with electrical feed-through (EDF), an additional seal must be placed between cam disk and distributor plate.
- Connect inductive proximity switches and secure cable, see sensor assembly and operating manual.
- Remove the corresponding cover disk on the housing (5).
- Screw bracket (9, 10, 11) into the countersink of the housing (5) provided until the clamping sleeve (4) can still be turned.
- Turn swivel unit counter-clockwise to the corresponding stop or the center position.

Or with movable switch cams: Loosen set-screw of the switch cam (7) and push switch cam (7) until it is positioned at the height of the corresponding clamping sleeve (4).
- Turn swivel unit back to the output position and secure the switch cam (7).
- Turn swivel unit counter-clockwise to the corresponding stop or the center position.
- Insert inductive proximity switches up to stop into the clamping sleeve (4).
- Unscrew clamping sleeve (4) until the sensor switches.
- Tighten the screw (3) until the clamping sleeve (4) can no longer be turned.
 - ✓ Screw (3) jams the clamping sleeve (4) and at the same time secures the bracket (9, 10, 11).
- Tighten clamping screws (1) until the inductive proximity switch is mounted.
- Check switching positions, set again if necessary.

6 Start-up

6.1 Setting ranges of the variants

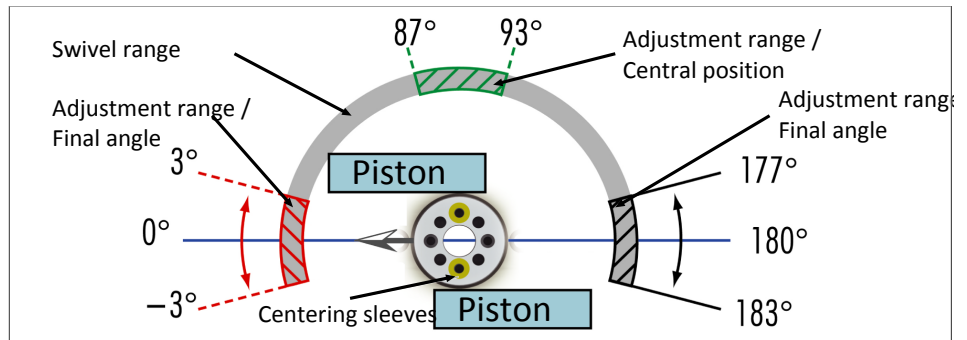

End position adjustability 3°

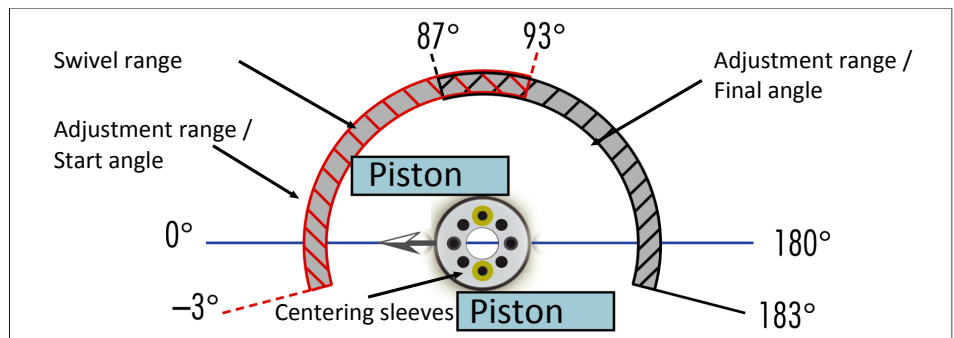

End position adjustability 90°

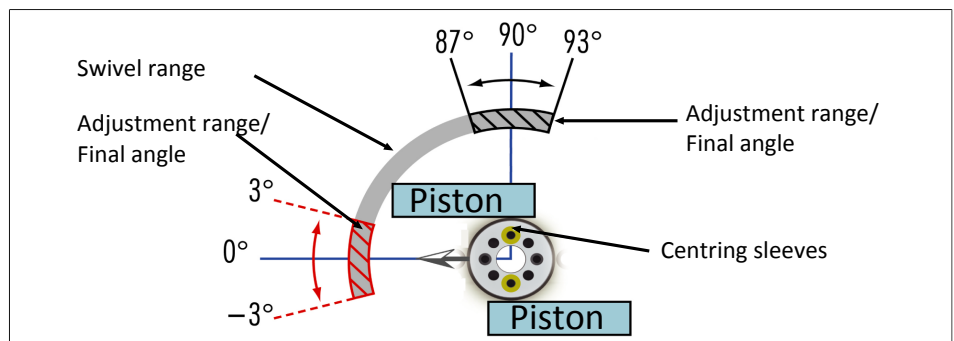

Variant angle of rotation 90°

6.2 Base unit

Move to basic setting 180° (end position B)

- Actuate air connection "A", pinion begins to move.
- ✓ Assembly swivels in clockwise direction until it reaches the end position "B".

Move to basic setting 0° (end position A)

- Actuate air connection "B", pinion begins to move.
- ✓ Assembly swivels until it reaches the end position "A".

6.3 Center position

NOTE

The center position can be adjusted by $\pm 3^\circ$. By design, overshooting can occur in the center position.

Move to basic setting 90° (center position)

- Actuate air connection "C" and "D" together, pinion begins to move.
- ✓ Assembly swivels into center position.

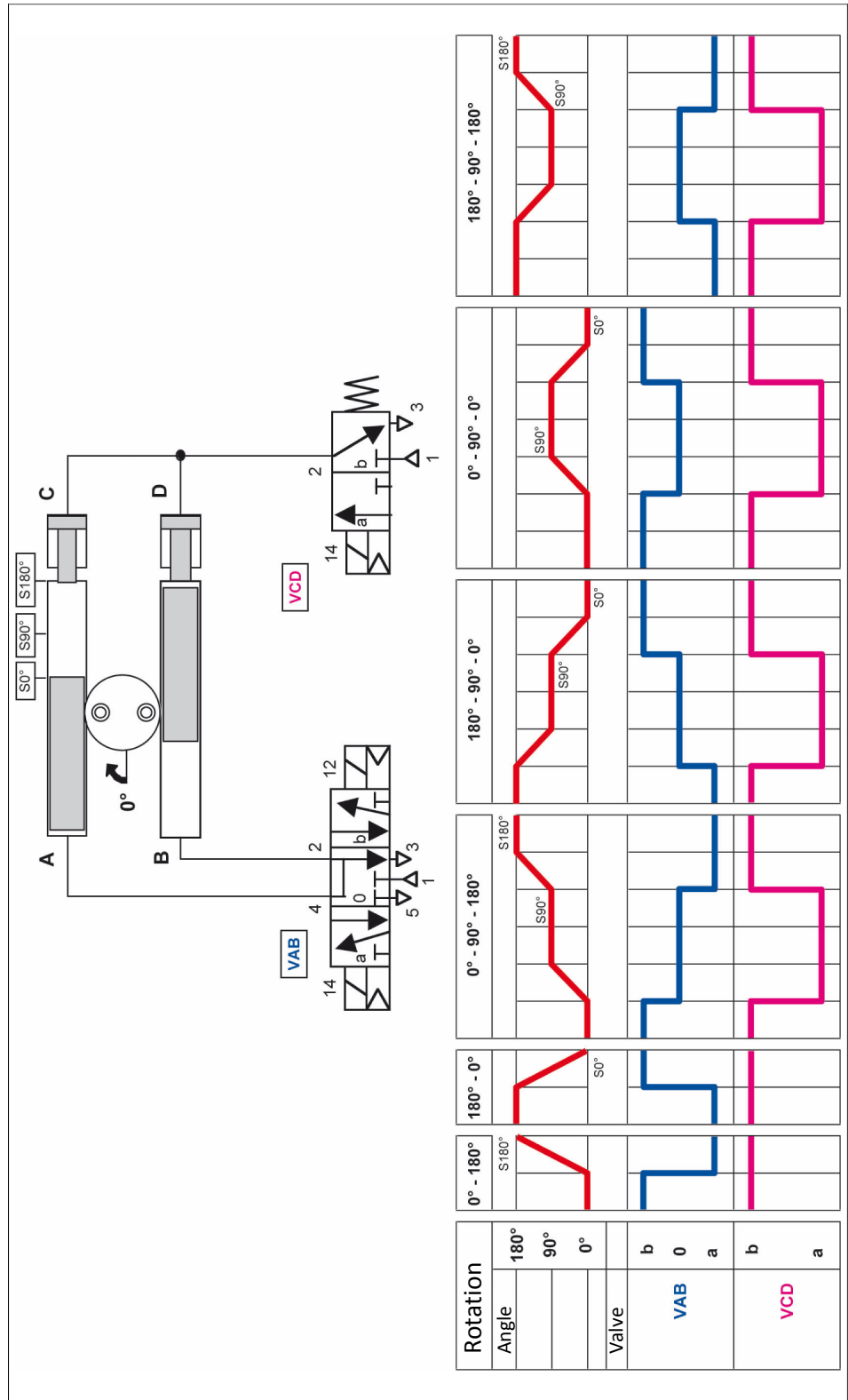

Electrical circuit diagram actuation with one 5/3 and one 3/2 directional control valve, example

6.4 Locked center position



⚠ WARNING

Risk of injury due to unexpected movement of the machine/system!

In an EMERGENCY STOP situation, the center position lock can come loose.

- Swivel the product to one of the end positions to restart.

CAUTION

Damage due to erroneous control!

Erroneous control may damage the pistons.

- The locking pistons must be free to extend without striking the drive pistons.
- Observe electrical circuit diagram, electrical circuit diagram actuation with two 5/3 directional control valves (example).

If this option is selected, the locking pistons can stop the rotating motion in the center position and enable it again. The center position can be adjusted by $\pm 3^\circ$.

Move from 0° position to the center position

- Extend locking piston "C".
- Actuate air connection "A", pinion begins to move.
- ✓ Assembly swivels into center position.

Move from 180° position to the center position

- Extend locking piston "D", pinion begins to move.
- Actuate air connection "B".
- ✓ Assembly swivels into center position.

NOTE

Before actuating "C" and "D", connections "A and "B" must be completely ventilated. Observe the waiting period here, [electrical circuit diagram actuation with two 5/3 directional control valves, example](#) [▶ 56].

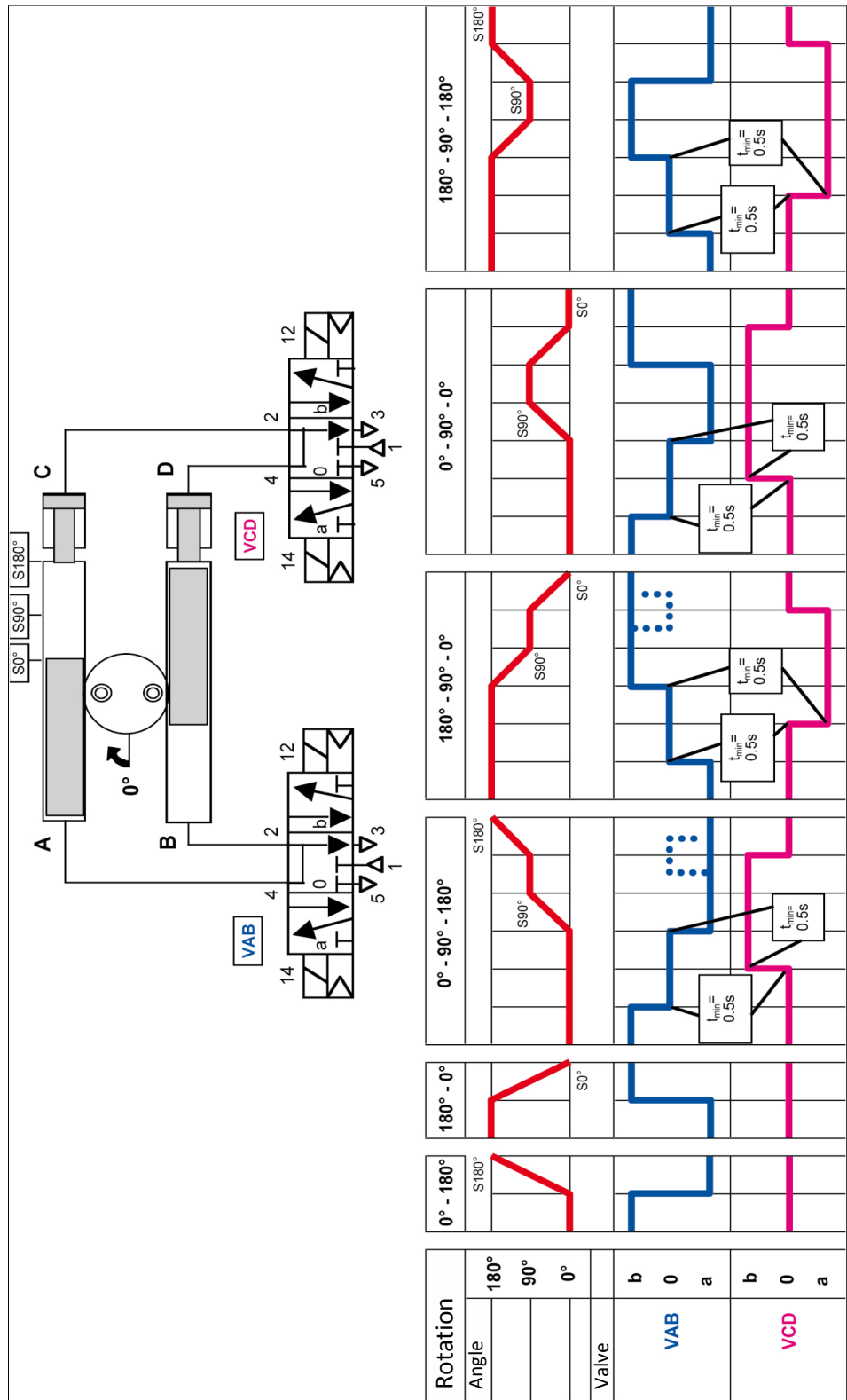

Electrical circuit diagram actuation with two 5/3 directional control valves, example

6.5 Locked center position with separate piston chambers



⚠ WARNING

Risk of injury due to unexpected movement of the machine/system!

In an EMERGENCY STOP situation, the center position lock can come loose.

- Swivel the product to one of the end positions to restart.



⚠ WARNING

Risk of injury due to unexpected movement of the machine/system!

With a horizontal swiveling axis, secure locking is not guaranteed during the ventilation stage when a swivelling movement is being performed from 3 o'clock (180°) to 6 o'clock (90°) or from 9 o'clock (0°) to 6 o'clock (90°).

- Screw the separating sleeves into air connections "A" and "B".
- Control both piston chambers of the "A" and "B" air connections separately for the purpose of holding torque.

The piston chambers "A" and "B" are separated by one separating sleeve each into two independent piston chambers, "A1" and "A2" and "B1" and "B2". By using supply air throttle valves, piston chambers can be actuated separately.

Holding the load at 0°

- Actuate air connection "B1", until the pinion begins to move.
- Ventilate air connection "B2".
- Actuate air connection "C".
- Observe waiting period, [Electrical circuit diagram holding the load at 0°](#) [▶ 58].
- Ventilate air connection "B1".
- Actuate air connections "A1" and "A2".
- ✓ Assembly swivels until locking of C.

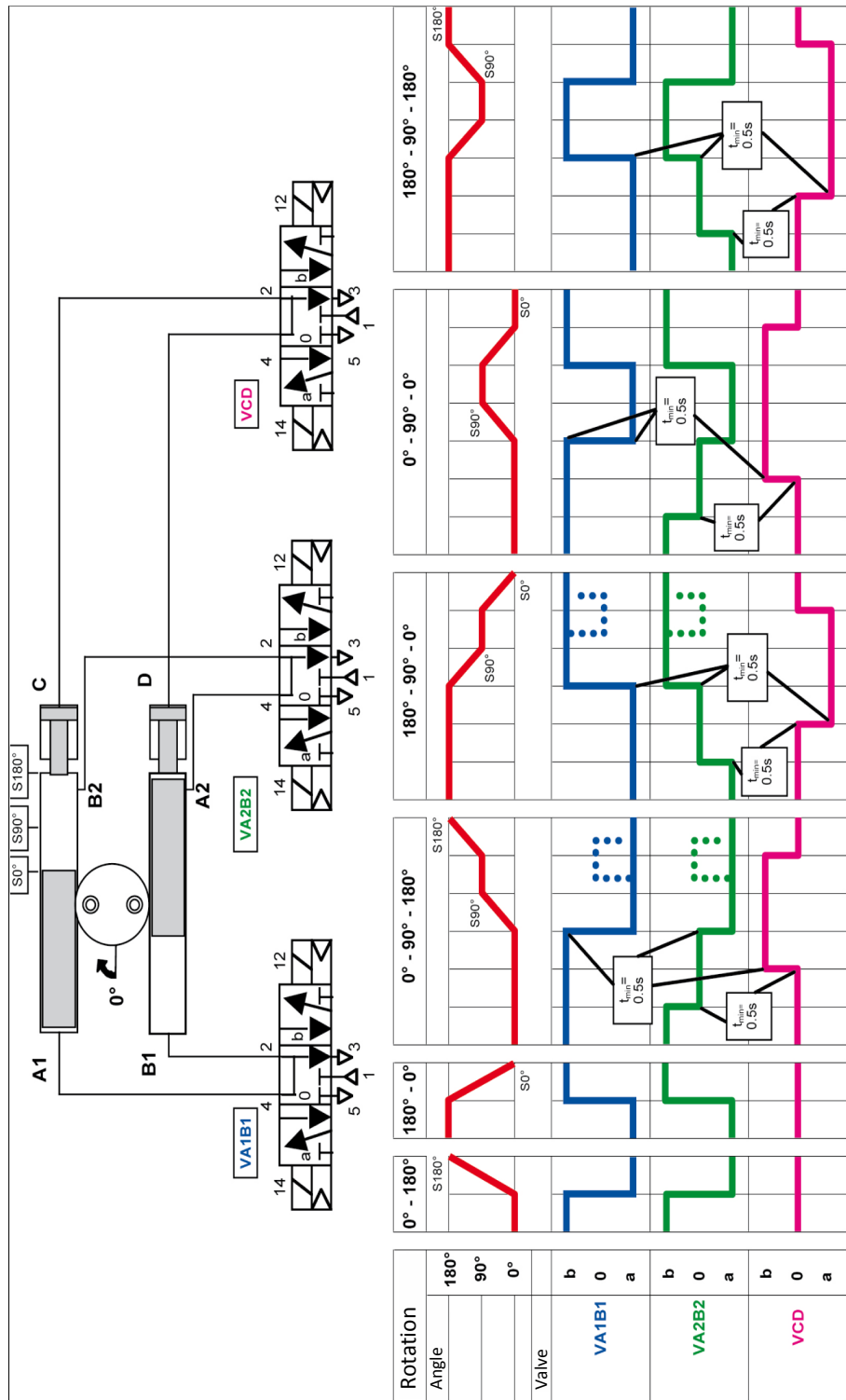

Electrical circuit diagram holding the load at 0°

The following actuation is advantageous for variants from size 35 and larger depending on the application:

- A brief ventilation while the lock is being released ensures smooth travel to the limit position.
- Exhaust air throttle valves can be used for air connections "A1" and "B1" by installing separating sleeves. The air connections "A2" and "B2" then remain unthrottled.

7 Troubleshooting

7.1 Product does not move smoothly to the end positions

| Possible cause | Corrective action |
|---------------------------|---|
| Dampening stroke shifted. | Adjust absorber stroke. Adjust absorber stroke [▶ 41] |
| Shock absorber defective. | Check or, if need be, replace the shock absorber. Maintenance [▶ 61] |

7.2 Product does not travel through the rotating angle

| Possible cause | Corrective action |
|---|---|
| Accumulation of dirt between stop / sleeve and pistons. | Clean and lubricate product. Maintenance [▶ 61] |
| End positions are adjusted incorrectly. | Adjust end position. Adjust swivel angle [▶ 38] |
| Pressure drops below minimum. | Check air supply. Pneumatic connection [▶ 31] |
| Components have come loose e.g. due to overloading. | Send product with a SCHUNK repair order or dismantle product. |
| Shock absorber defective. | Check or, if need be, replace the shock absorber. Maintenance [▶ 61] |

7.3 Product rotates jerkily

| Possible cause | Corrective action |
|--|---|
| Too little grease in the mechanical guiding areas. | Clean and lubricate product. Maintenance [▶ 61] |
| Compressed air lines blocked. | Check compressed air lines of damage. |
| Swiveling speed set too fast | Adjust swiveling speed Adjust swiveling speed [▶ 40] |

7.4 Product does not move

| Possible cause | Corrective action |
|--|---|
| Component part defective. | Replace component or send it to SCHUNK for repair. |
| | Have Schunk check the application. |
| Pressure drops below minimum. | Check air supply. Pneumatic connection [▶ 31] |
| Compressed air lines switched. | Check compressed air lines. |
| Unused air connections open. | Close unused air connections. Pneumatic connection [▶ 31] |
| Both exhaust air throttle valves are closed. | Open one exhaust air throttle valve. |
| Proximity switch defective or set incorrect. | Adjust sensor or if necessary change sensor. Installing the sensors [▶ 45] |

7.5 Torque is diminishing

| Possible cause | Corrective action |
|---|--|
| Compressed air can escape. | Check seals, if necessary, disassemble the product and replace seals. Disassembly and assembly [▶ 71] |
| Too much grease in the mechanical movement space. | Clean and lubricate product. Maintenance [▶ 61] |
| Pressure drops below minimum. | Check air supply. Pneumatic connection [▶ 31] |

8 Maintenance

8.1 Notes



⚠ DANGER

Danger of explosion in potentially explosive areas!

- Observe supplementary sheet for products with explosion-resistant versions "SRU-plus -...-EX".

Original spare parts

Use only original spare parts of SCHUNK when replacing spare and wear parts.

8.2 Maintenance interval

CAUTION

Material damage due to hardening lubricants!

Lubricants harden more quickly at temperatures above 60°C, leading to possible product damage.

- Reduce the lubricant intervals accordingly.

| Interval [Mio. cycles] for SRU-plus 20 - 60 | Maintenance work |
|---|--|
| Daily | Visually inspect the function of the shock absorbers Inspect shock absorbers [▶ 63] |
| Interval [Mio. cycles] for SRU-plus 20 - 40 | Maintenance work |
| 2 | Clean all parts thoroughly, check for damage and wear, if necessary replace seals and wearing parts, Disassembly and assembly [▶ 71]. |
| 2 | Treat all grease areas with lubricant, Lubricants/Lubrication points (basic lubrication) [▶ 62]. |
| 2 | Check that the shock absorbers are working, if necessary replace shock absorber Replace shock absorber [▶ 68] |

| Interval [Mio. cycles] for SRU-plus 50 - 60 | Maintenance work |
|---|--|
| 1 | Clean all parts thoroughly, check for damage and wear, if necessary replace seals and wearing parts, Disassembly and assembly [▶ 71]. |
| 1 | Treat all grease areas with lubricant, Lubricants/Lubrication points (basic lubrication) [▶ 62]. |
| 1 | Check that the shock absorbers are working, if necessary replace shock absorber Replace shock absorber [▶ 68] |

8.3 Lubricants/Lubrication points (basic lubrication)

SCHUNK recommends the lubricants listed.

During maintenance, treat all greased areas with lubricant. Thinly apply lubricant with a lint-free cloth.

| Lubricant point | Lubricant |
|--------------------------|-------------|
| The teeth and the pinion | Flexolub A1 |
| All seals | Sealgood 1 |

8.4 Inspect and set shock absorbers

8.4.1 Inspect shock absorbers

The shock absorbers are specially tested and can only be acquired from SCHUNK. The shock absorbers have a limited lifespan, depending on the load.

- Regularly check that the shock absorbers are working.
 - ✓ The shock absorber is working correctly if the product moves softly into the end positions when set correctly and the prescribed swiveling time is reached.

8.4.2 Set shock absorber overhang

For production reasons, shock absorbers may be of different sizes. If a shock absorber is exchanged, the new shock absorber with fitting disks must be set to the corresponding shock absorber overhang (h).

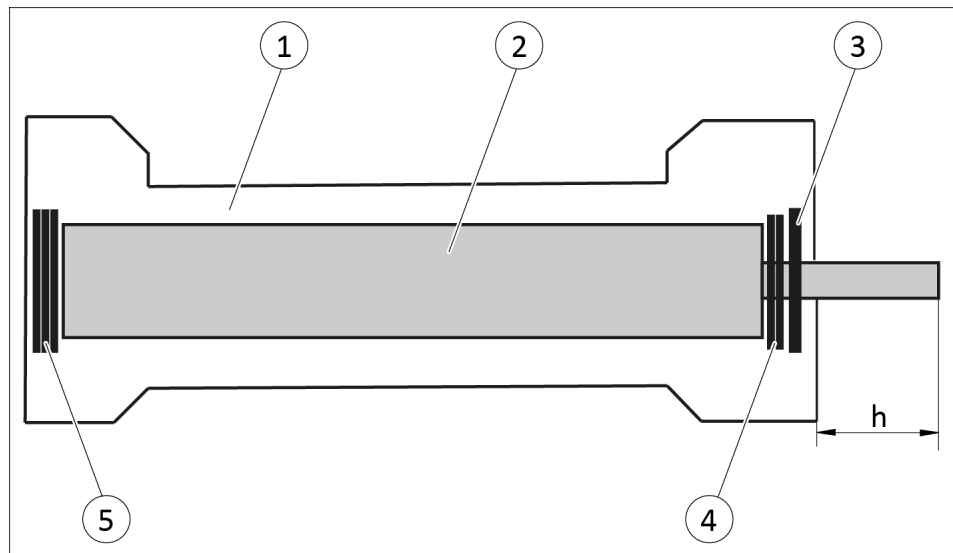

- First set the shock absorber overhang (h) of the shock absorber (2) in the piston (1) with fitting disks (5) [Shock absorber types and overlap](#) [▶ 64].
- After this, reduce the play of the shock absorber (2) to the safety ring (3) with fitting disks (4).
 - ✓ The shock absorber (2) must be fitted in the pistons (1) as free from play as possible.

8.4.3 Shock absorber types and overlap

| Type | Basic | | | Locked center position | | |
|---------|--------------------|---|----------------|------------------------|--------------------------------|----------------|
| | Shock absorber | Shock absorber overhang h [mm] | Tolerance [mm] | Shock absorber | Shock absorber overhang h [mm] | Tolerance [mm] |
| 20 W | FED 14 | 4.6 (without spring) | -0.2 | --- | --- | --- |
| 20 S | DED | (insertion not required) | --- | --- | --- | --- |
| 20 W VM | FED 14 | 4.6 (without spring) | -0.2 | WP-M 0.25-356 | 9.5 | ± 0.05 |
| 25 W | WP-M 0.4-266 | 14 | -0.1 | --- | --- | --- |
| 25 H | WP-M 0.4-366 | 14 | -0.1 | --- | --- | --- |
| 25 W VM | WP-M 0.4-266 VM | 10 | -0.1 | WP-M 0.4-266 G | 14 | -0.1 |
| 30 W | WP-M 0.6-466 | 19.5 | -0.1 | --- | --- | --- |
| 30 H | WP-M 0.6-566 | 16 | -0.1 | --- | --- | --- |
| 30 W VM | WP-M 0.6-566 VM | 12 | -0.1 | WP-M 0.6-466 G | 19 | -0.1 |
| 35 W | WP-M 0.6-366 | 19.5 | -0.1 | --- | --- | --- |
| 35 H | WP-M 0.6-366 | 19.5 | -0.1 | --- | --- | --- |
| 35 W VM | WP-M 0.6-466 VM | 17.2 | -0.1 | WP-M 0.6-366 G | 19 | -0.1 |
| 40 W | WP-M 1.0-266 | Place fitting disks on shock absorber until it sits in the piston free from play, Set shock absorber overhang [► 63]. | | --- | --- | --- |
| 40 H | WP-M 1.0-466 | | | --- | --- | --- |
| 40 W VM | WP-M 1.0-266 | 19.4 | -0.1 | WP-M 1.0-266 G | 22 | -0.1 |

| Type | Basic | | | Locked center position | | |
|------------|--------------------------|---|----------------|------------------------|--------------------------------|----------------|
| | Shock absorber | Shock absorber overhang h [mm] | Tolerance [mm] | Shock absorber | Shock absorber overhang h [mm] | Tolerance [mm] |
| 50 W | WP-M 1.0-266 | Place fitting disks on shock absorber until it sits in the piston free from play, Set shock absorber overhang [▶ 63]. | | --- | --- | --- |
| 50 H | WP-M 1.0-466 | | | --- | --- | --- |
| 50 W VM | WP-M 1.0-266 | 20.4 | -0.1 | WP-M 1.0-266 G | 22 | -0.1 |
| 60 W | WP-M 1.25x2-266 | Place fitting disks on shock absorber until it sits in the piston free from play, Set shock absorber overhang [▶ 63]. | | --- | --- | --- |
| 60 W VM | WP-M 1.25x2-266 VM | | | WP-M 1.0-266 G | 23 | -0.1 |

8.5 Servicing shock absorber

8.5.1 Servicing shock absorber (SRU-plus 20-W)

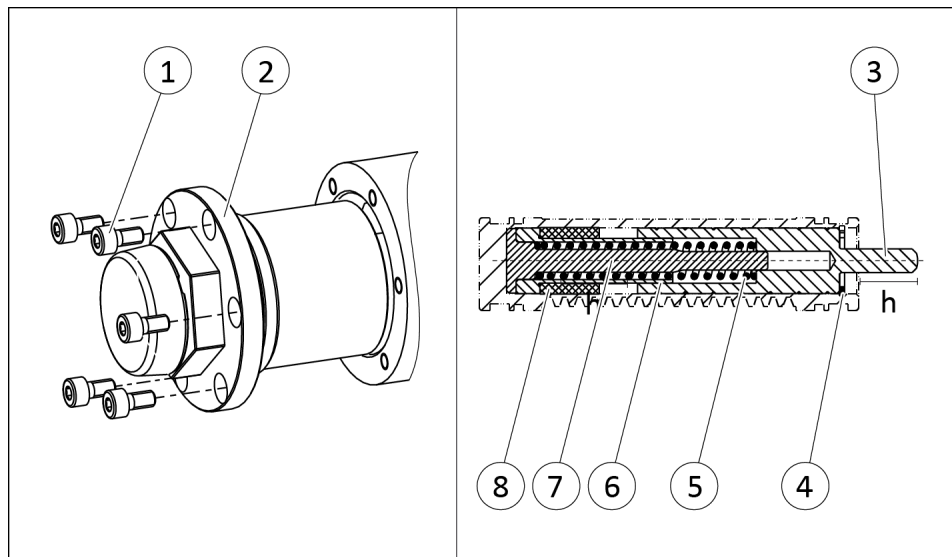

- Undo the screws (1).
- Pull off the stop cover (2).
- Remove the safety ring (4) from the piston.
- Pull out the piston rod (3) and remove the compression spring (5).
- Pull out the piston (7) with the guide sleeve (6) and dampening ring (8).
- Replace dampening ring (8).
- Insert the piston (7) with the guide sleeve (6) and dampening ring (8) using the piston rod (3) as far as possible.
- Check the shock absorber overlap (h), [Shock absorber types and overlap](#) [▶ 64].
 - ✓ If necessary, add or remove fitting disks on base side until the required absorber overlap (h) is reached.
- Remove the piston rod (3).
- Grease and insert the compression spring (5).
- Grease the piston rod (3) inside and outside and insert it.
- Mount the safety ring (4).
 - ✓ Pay attention to the correct installation position of the safety ring.
- Mount the stop cover (2) with screws (1).

8.5.2 Servicing the shock absorber (SRU-plus 20-S)

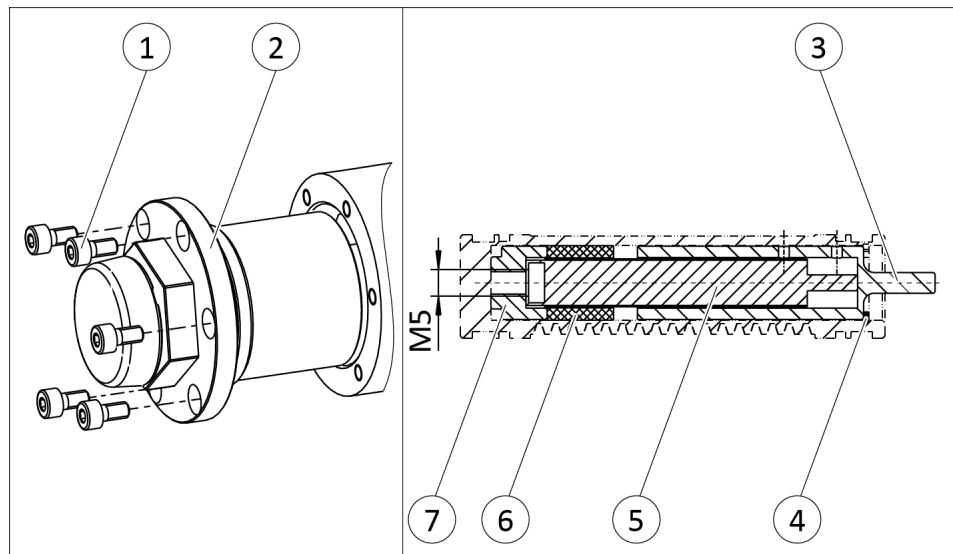

- Undo the screws (1).
- Pull off the stop cover (2).
- Remove the safety ring (4) from the piston.
- Pull out the piston rod (3) and remove the absorber (5).
- Use the M5 thread to pull out the cover (7) and dampening ring (6).
- Replace dampening ring (6).
- Insert the cover (7) with the dampening ring (6) using the piston rod (3) as far as possible.
- Remove the piston rod (3).
- Grease and insert the shock absorber (5).
- Grease the piston rod (3) inside and outside and insert it.
- Remount the safety ring (4).
 - ✓ Pay attention to the correct installation position of the safety ring.
- Mount the stop cover (2) with screws (1).

8.6 Replace shock absorber

8.6.1 Replace shock absorber (base unit)

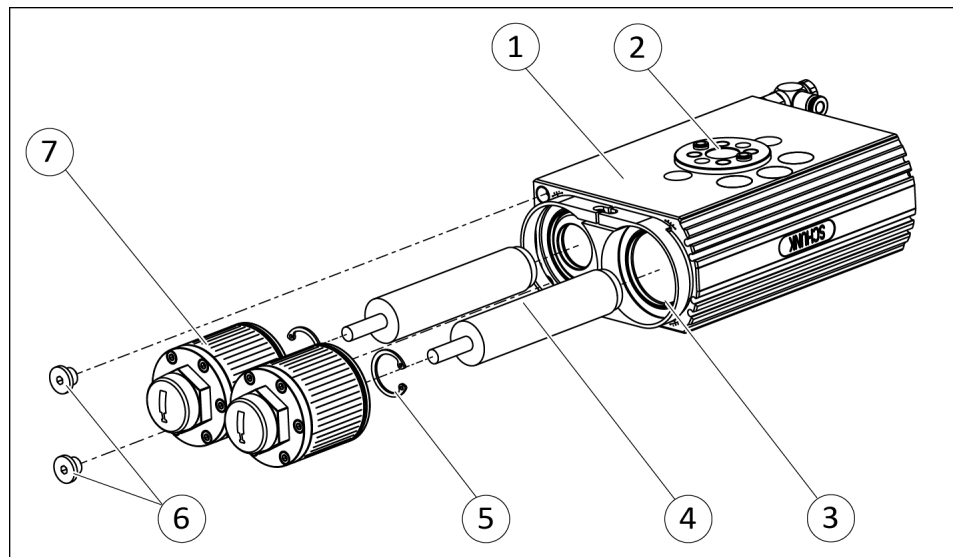

- Ventilate rotary actuator.
- Unscrew screws (6).
- Turn pinion (2) to end position.
- Remove stop cover (7).
- Remove safety ring (5) on piston (3).
- Pull out shock absorber (4) with fitting disks.
- Insert new shock absorbers.
- Set shock absorber overhang (h),
[Set shock absorber overhang](#) [▶ 63].
- Set safety ring (5) in the groove of the piston.
- Turn pinion (2) to end position.
 - ✓ Piston (3) is retracted into the housing (1).
- Screw on stop cover (7) again.
- Proceed analogously for the second shock absorber.
- If necessary, adjust the shock absorber, [Settings](#) [▶ 36].

8.6.2 Replacing external shock absorber (locked center position)

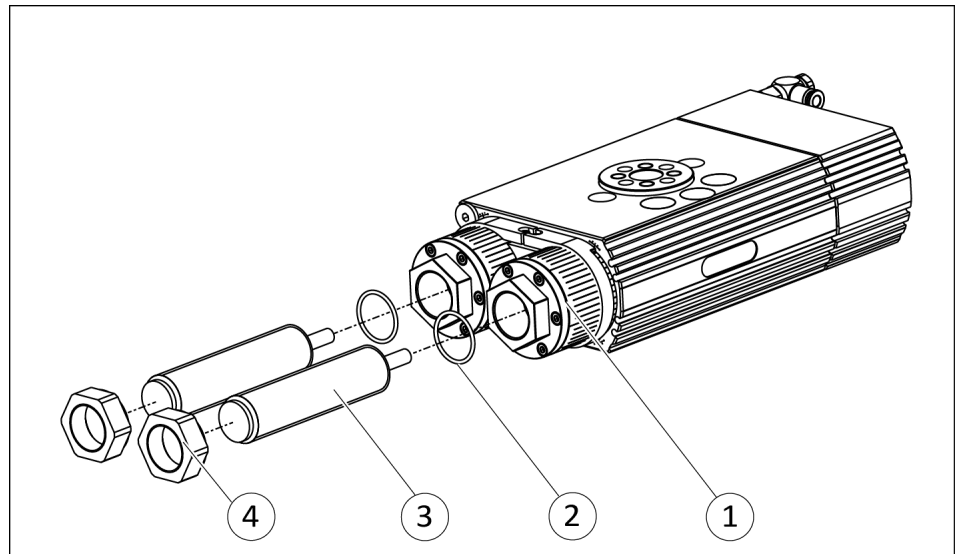

- Fix stop (1) and unscrew the sealing nut (4) of the shock absorber (3).
- Turn shock absorber (3) out of the stop (1).
- Mount O-ring (2) on new shock absorber.
- Screw sealing nut (4) onto the shock absorber (3)
- Screw in new shock absorber as far as possible.
- Adjust absorber stroke, [Adjust absorber stroke](#) [▶ 41].
- Fix stop (1) and tighten the sealing nut (4) of the shock absorber (3).
- Swivel repeatedly to test the setting, if necessary set again, [Electrical circuit diagram with two 5/3 directional control valves \(example\)](#) [▶ 56].

8.6.3 Replace internal shock absorber (locked center position)



⚠ WARNING

Risk of injury due to spring forces!

In the interior of the centering housing (locked center position variant), a pre-loaded compression spring can be found.

- Carefully dismantle the product.

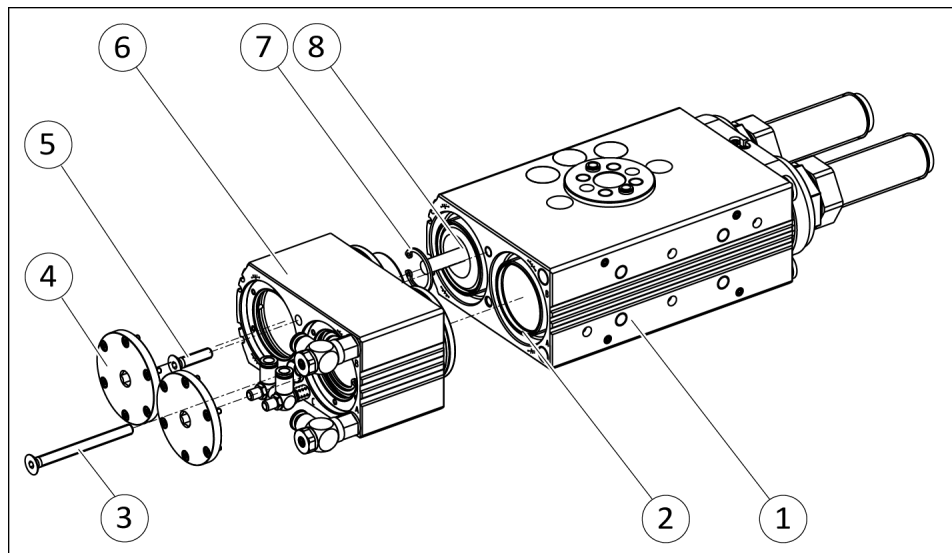

- Unscrew screw (5) on stops C and D (4) one turn.
- Unscrew bolt (3) of the limiting sleeve.
- Unscrew stops C and D (8) and in doing so retighten screw (3) until the centering housing (6) can be removed.
 - ✓ Unscrew both stops (4) evenly in order to prevent the centering housing (6) from tilting.
- Remove the safety ring (7) on piston (2).
- Pull out shock absorbers (8).
- **IMPORTANT! Carefully mount shock absorber in order to avoid damage to the O-rings.**
Insert new shock absorbers.
 - ✓ Observe shock absorber overhang, [Shock absorber types and overlap](#) [▶ 64].
- Remount the safety ring (7).
- Press stops C and D into the centering housing (6) until they are flush with the centering housing (6).
- Fit centering housing (6) to the base unit (1) and slightly tighten the stops C and D.
- Slightly tighten screw (3).
- Press centering housing (6) onto the base unit (1) and evenly tighten the stops C and D as well as the screw (5).

- Tighten screw (3) and then loosen approx. 1/4 revolution.
- Swivel repeatedly to test the setting, if necessary set again [Electrical circuit diagram with two 5/3 directional control valves \(example\)](#) [▶ 56].

8.7 Disassembly and assembly

8.7.1 Dismantling and assembling rotary actuator (base unit)

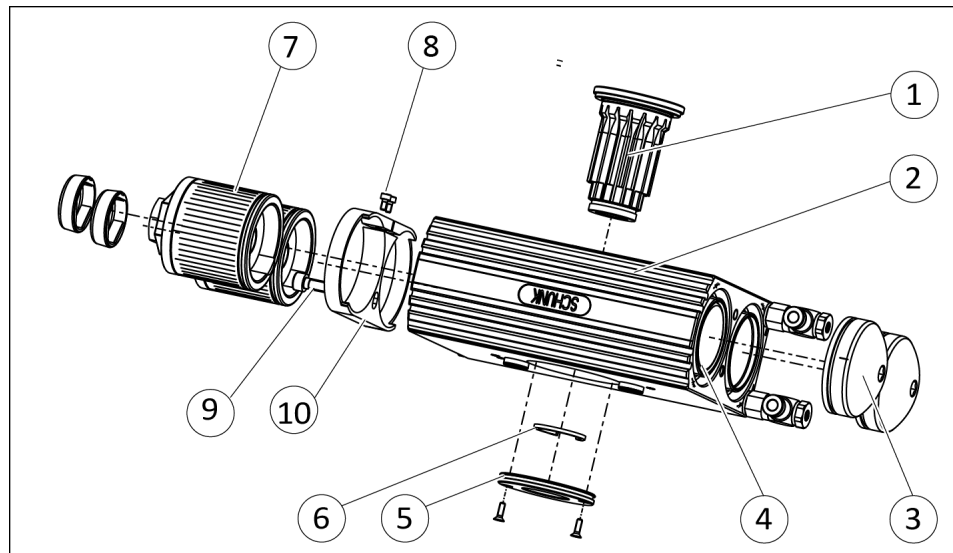

- Ventilate rotary actuator.
- Remove all air connections, [Pneumatic connection](#) [▶ 31].
- Dismantle sensors if necessary.
- Unscrew screws (8),(9) and remove clamp shell (10), then remove both stop covers (7).
- Remove curved cover (3).
- Mark the installation position of the pinion (1) and the pistons (4).
- Unscrew protective cover (5).
- Remove safety ring (6) on pinion (1).
- Take pinion (1) out of the housing (2).
- Take both pistons (4) out of the housing (2).
- Assemble rotary actuator in the reverse order.
 - ✓ Unless otherwise specified, secure all screws and nuts with Loctite no. 243 and tighten with the appropriate tightening torque.

8.7.2 Dismantle and assemble rotary actuator (center position/locked center position)

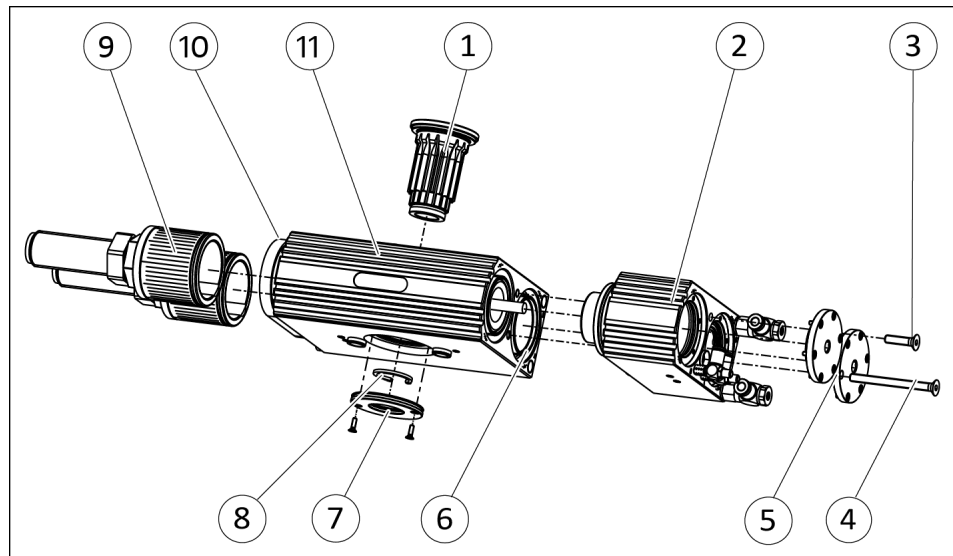

- Ventilate rotary actuator.
- Remove all air connections, [Pneumatic connection](#) ▶ 31].
- Dismantle sensors if necessary.
- Unscrew screws (10) and remove both stop covers (9).
- Unscrew screw (4) on stops "C" and "D" (5) one turn.
- Unscrew screw (3) of the limiting sleeve.
- Unscrew stops "C" and "D" (5) and in doing so retighten screw (4) until the centering housing (2) can be removed.
 - ✓ Unscrew both stops (5) evenly in order to prevent the centering housing (2) from tilting.
- Mark the installation position of the pinion (1) and the pistons (6).
- Unscrew protective cover (7).
- Remove safety ring (8) on pinion (1).
- Take pinion (1) out of the housing (11).
- Take both pistons (6) out of the housing (11).
- Assemble rotary actuator in the reverse order.
 - ✓ Unless otherwise specified, secure all screws and nuts with Loctite no. 243 and tighten with the appropriate tightening torque.

8.7.3 Dismantling and assembling rotary actuator (fluid feed-through)

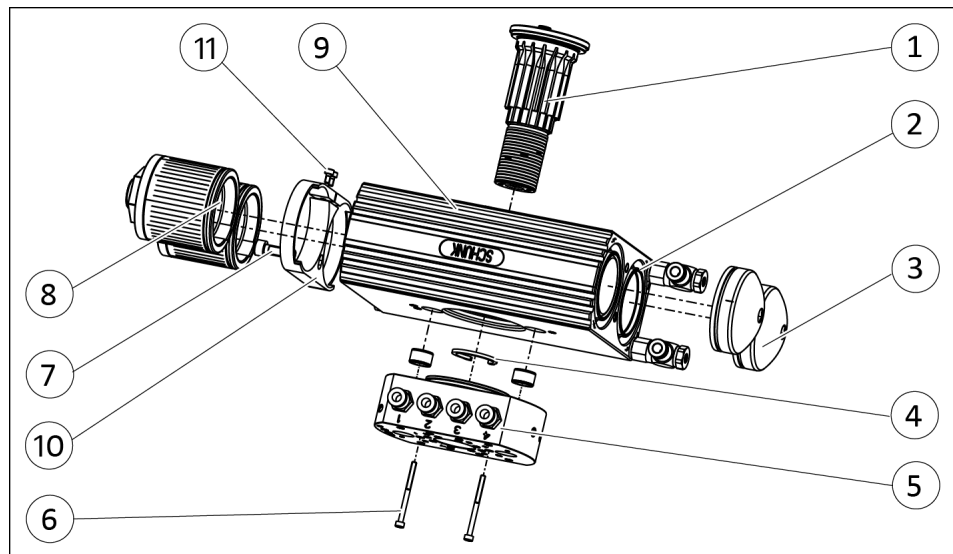

- Ventilate rotary actuator.
- Remove all air connections, [Pneumatic connection](#) [▶ 31].
- Dismantle sensors if necessary.
- Unscrew screws (7) and (11), remove clamp shell (10) and both stop cover (8).
- Mark the installation position of the pinion (1) and the pistons (2).
- Unscrew screws (6).
- Remove flange (5).
- Remove safety ring (4) on pinion (1).
- Take pinion (1) out of the housing (9).
- Take both pistons (2) out of the housing (9).
- Assemble rotary actuator in the reverse order.
 - ✓ Unless otherwise specified, secure all screws and nuts with Loctite no. 243 and tighten with the appropriate tightening torque.

8.7.4 Dismantling and assembling rotary actuator (EDF)

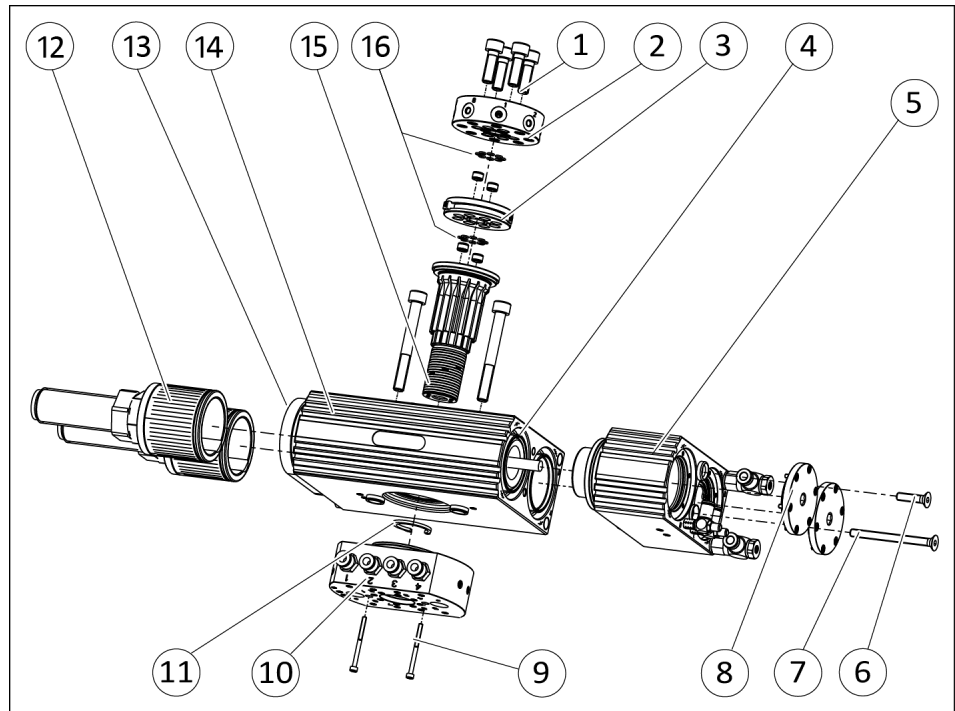

- Ventilate rotary actuator.
- Remove all air connections, [Pneumatic connection](#) [▶ 31].
- Remove all energy lines, [Electrical connection](#) [▶ 33].
- Unscrew screws (13) and remove both stop covers (12).
- Unscrew screw (7) on stops "C" and "D" (8) one turn.
- Unscrew screw (6) of the limiting sleeve.
- Unscrew stops C and D (8) and in doing so retighten screw (7) until the centering housing (5) can be removed.
 - ✓ Unscrew both stops (8) evenly in order to prevent the centering housing (5) from tilting.
- Mark the installation position of the pinion (15) and the pistons (4).
- Unscrew screws (9) and remove flange (10).
- Unscrew screws (1) and remove distributor plate (2) and sensor bracket (3).
- Remove safety ring (11) on pinion (15).
- Push the pinion (15) out of the housing (14).
- Take both pistons (4) out of the housing (14).
- Assemble rotary actuator in the reverse order.
 - ✓ Unless otherwise specified, secure all screws and nuts with Loctite no. 243 and tighten with the appropriate tightening torque.
 - ✓ **IMPORTANT! For the variant with electrical feed-through (EDF), a seal must be placed between pinion and cam disk and between cam disk and distributor plate.**

8.8 Assembly drawings

8.8.1 Overview of the components

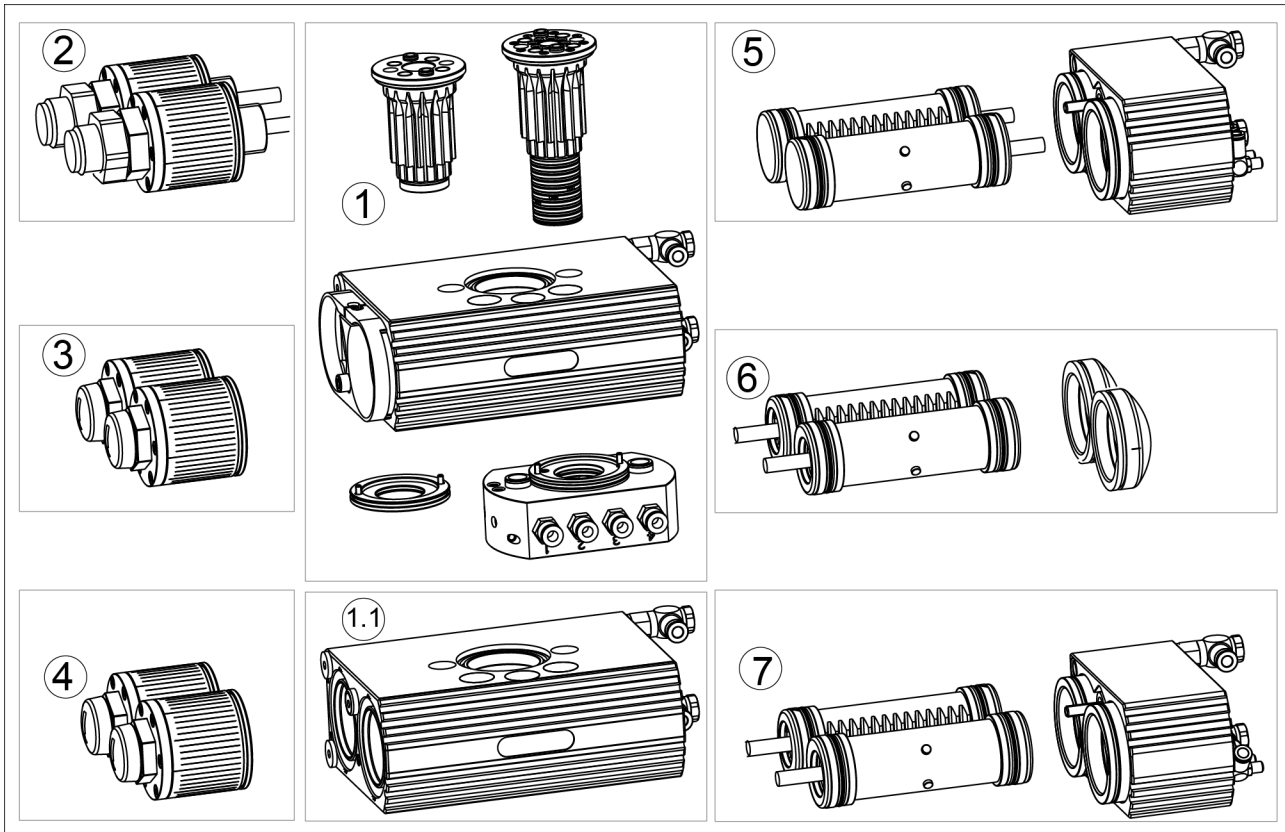

Overview of the assembly drawings

| | | |
|-----|--|---|
| 1 | Basic components with and without fluid feed-through | Basic components and fluid feed-through [▶ 76] |
| 1.1 | Variant "explosion-protected version" | |
| 2 | Stop-side locked center position (VM) | Fitting locked center position [▶ 77] |
| 3 | Stop side, end position adjustability 90° | Locating face end position adjustability 90° [▶ 77] |
| 4 | Stop side, end position adjustability 3° | Locating face end position adjustability 3° [▶ 77] |
| 5 | Piston and attachment locked center position (VM) | Addition locked middle position [▶ 78] |
| 6 | Pistons and cover of basic unit | Piston and cover basic unit [▶ 78] |
| 7 | Piston and attachment center position (M) | Addition center position [▶ 78] |

8.8.1.1 Basic components and fluid feed-through

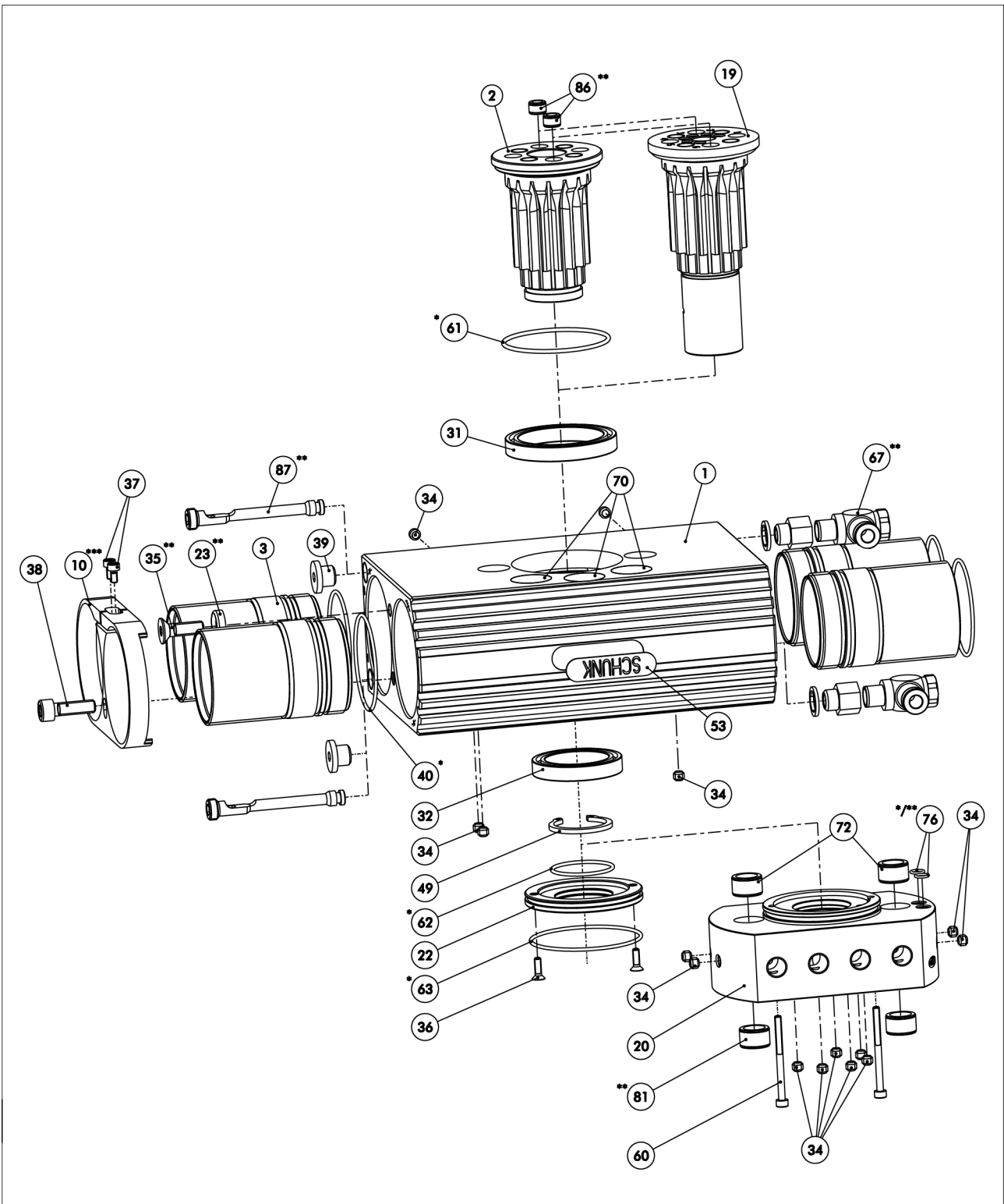

- * Contained in seal kit.
- ** Contained in accessory pack.
- *** Variants "explosion-protected version" does not include a clamp shell. They are clamped by an eccentric.

8.8.1.2 Fitting locked center position

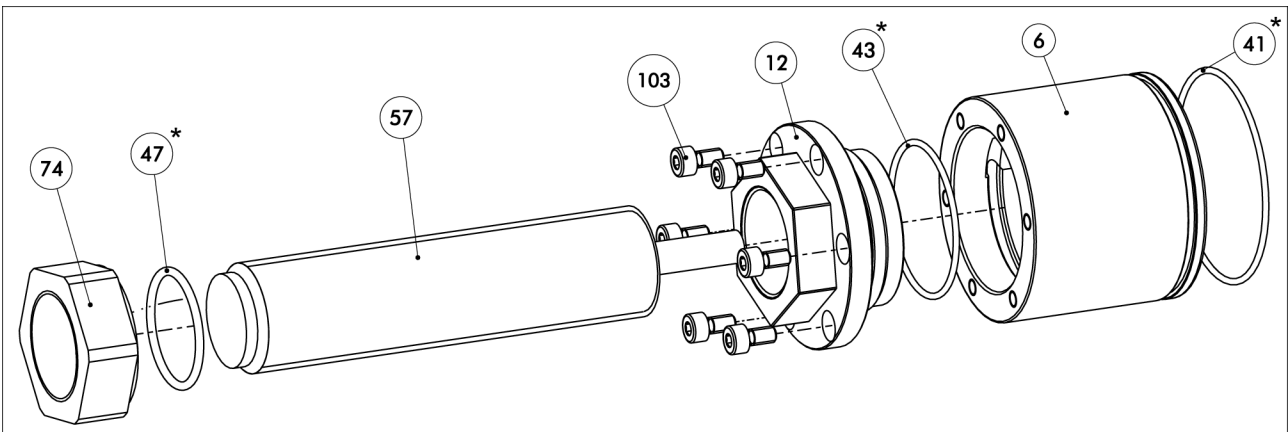

8.8.1.3 Locating face end position adjustability 90°

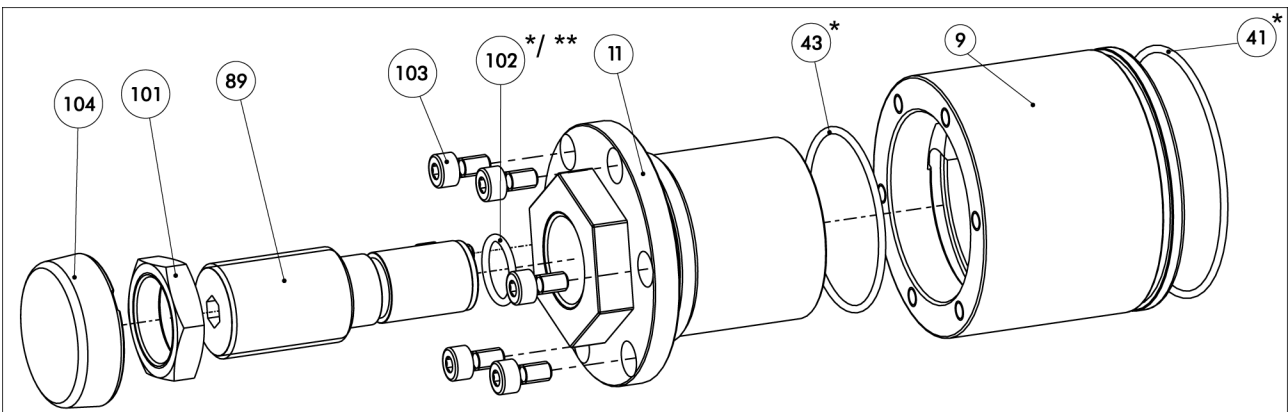

8.8.1.4 Locating face end position adjustability 3°

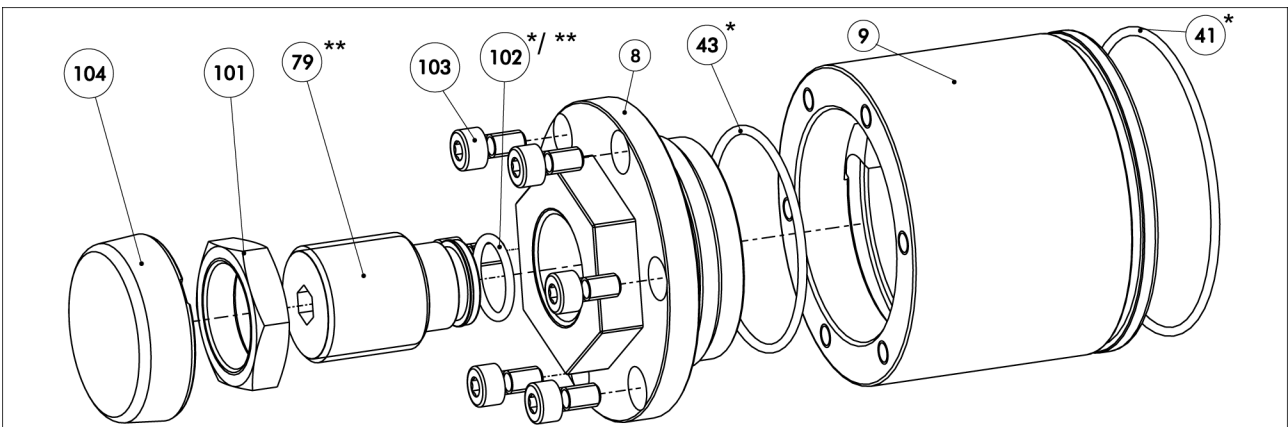

* Contained in seal kit. ** Contained in accessory pack.

8.8.1.5 Addition locked middle position

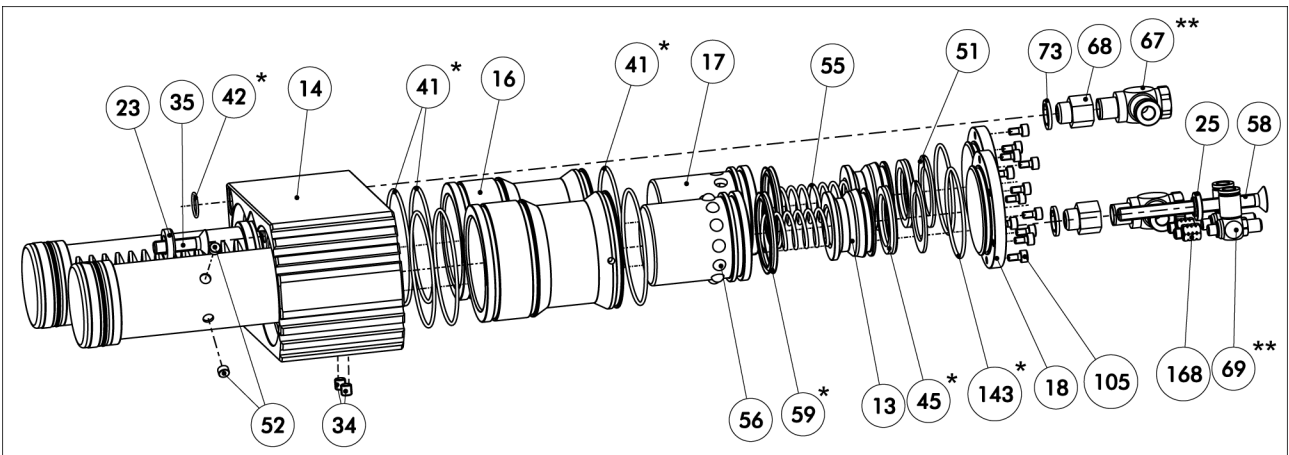

8.8.1.6 Piston and cover basic unit

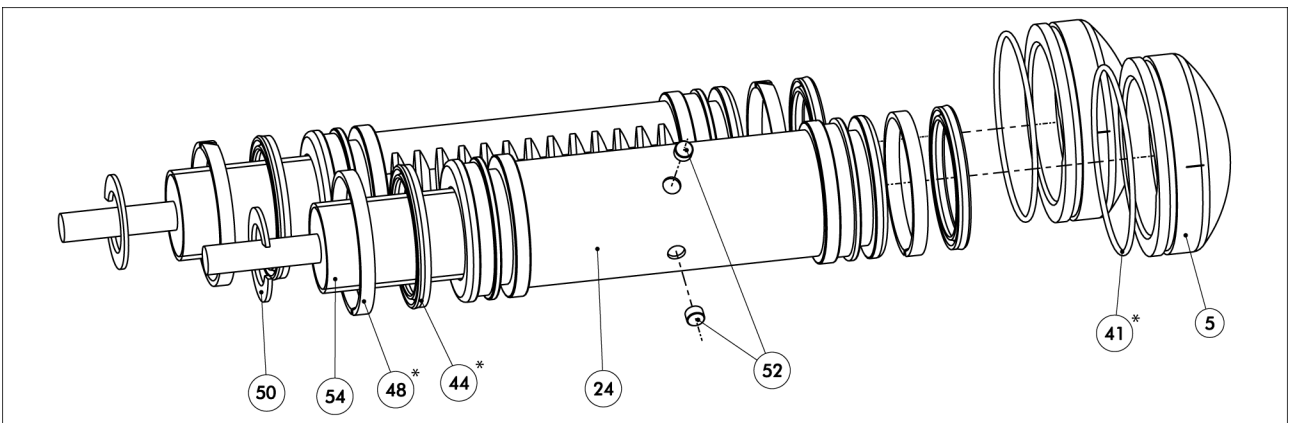

8.8.1.7 Addition center position

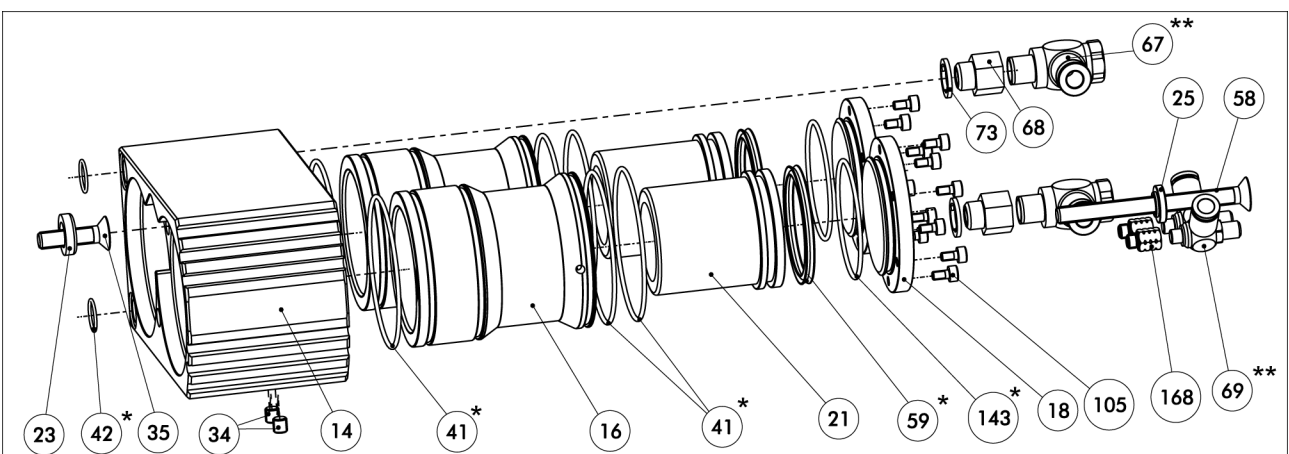

* Contained in seal kit.

** Contained in accessory pack.

8.8.2 Overview of the components (EDF)

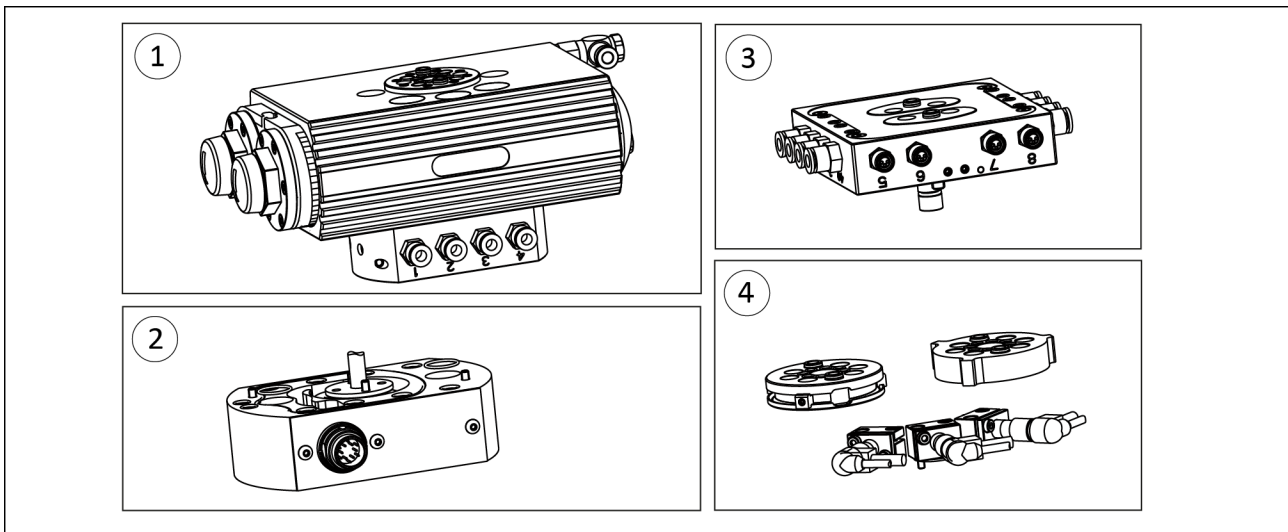

Component Overview

| | | |
|---|---|--|
| 1 | Basic components and fluid feed-through | Basic components and fluid feed-through [▶ 76] |
| 2 | Electrical feed-through | Distributor plate and electrical feed-through, size 20-25 [▶ 80] |
| 3 | Distributor plate | Distributor plate and electrical feed-through, size 20-25 [▶ 80] |
| 4 | Sensor holder with sensor | Mounting inductive proximity switch IN 80 [▶ 50] |

8.8.2.1 Distributor plate and electrical feed-through, size 20-25

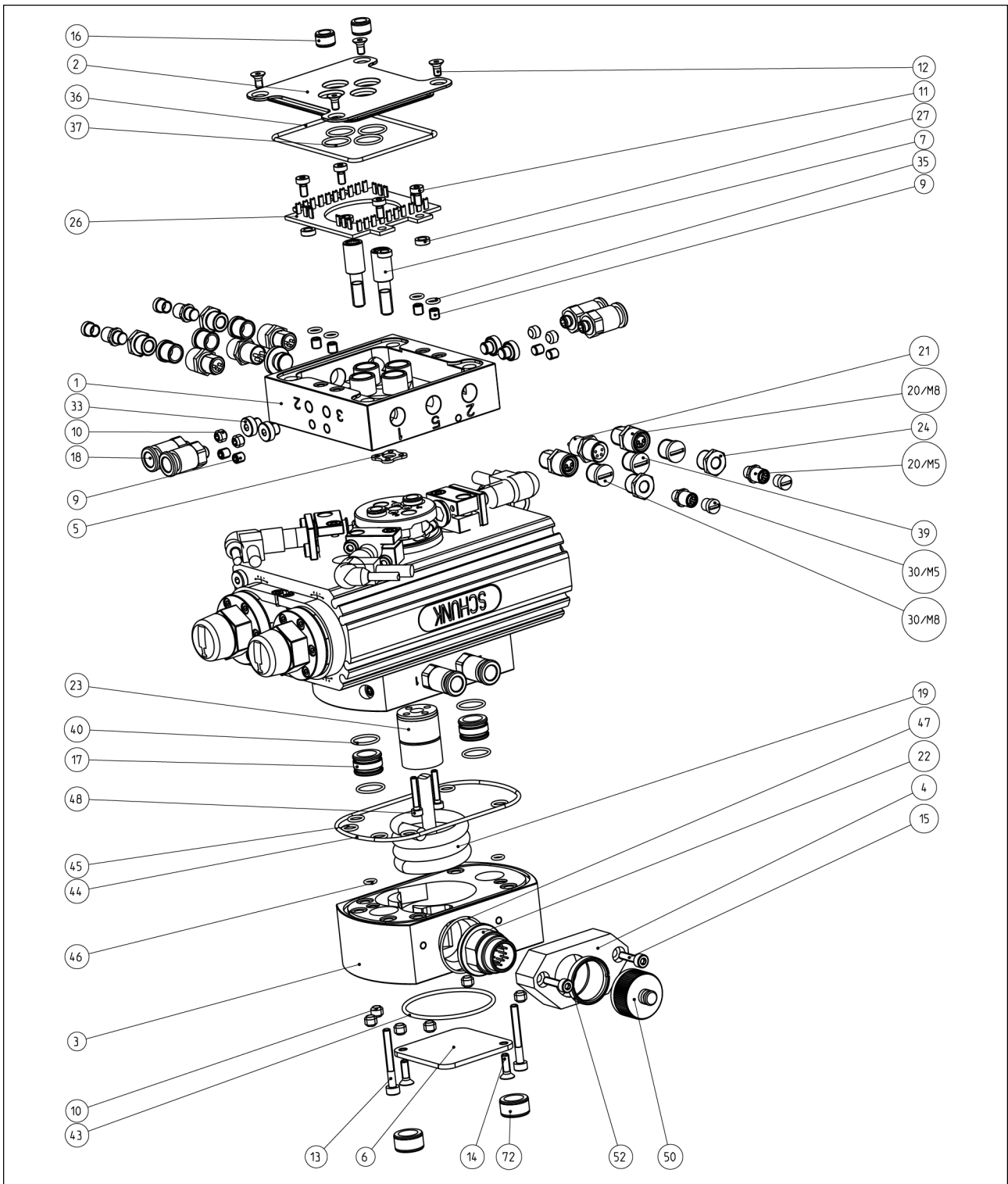

Distributor plate and electrical feed-through, size 20-25

8.8.2.2 Distributor plate and electrical feed-through, size 30

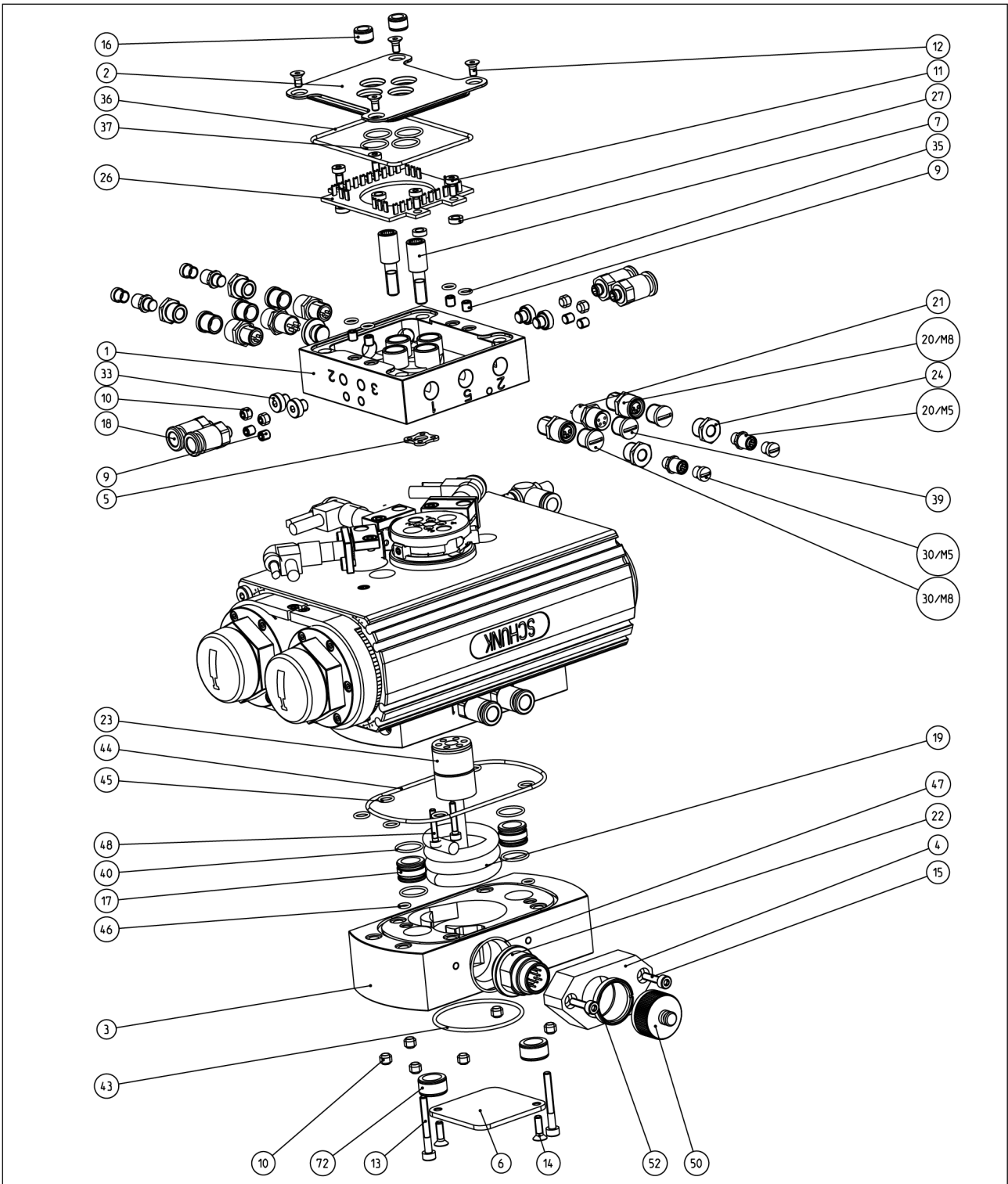

Distributor plate and electrical feed-through, size 30

8.8.2.3 Distributor plate and electrical feed-through, size 35

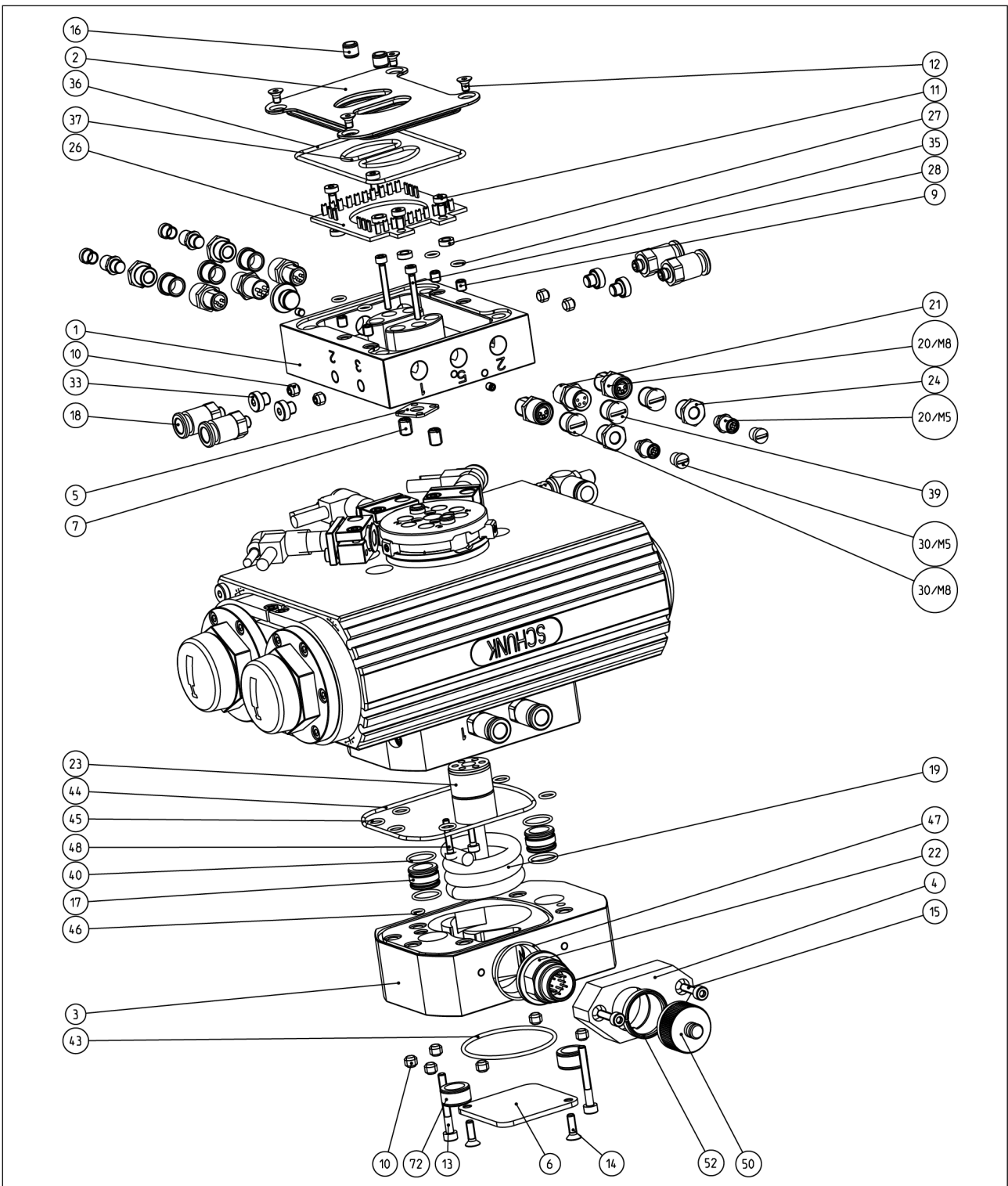

Distributor plate and electrical feed-through, size 35

8.8.2.4 Distributor plate and electrical feed-through, size 40

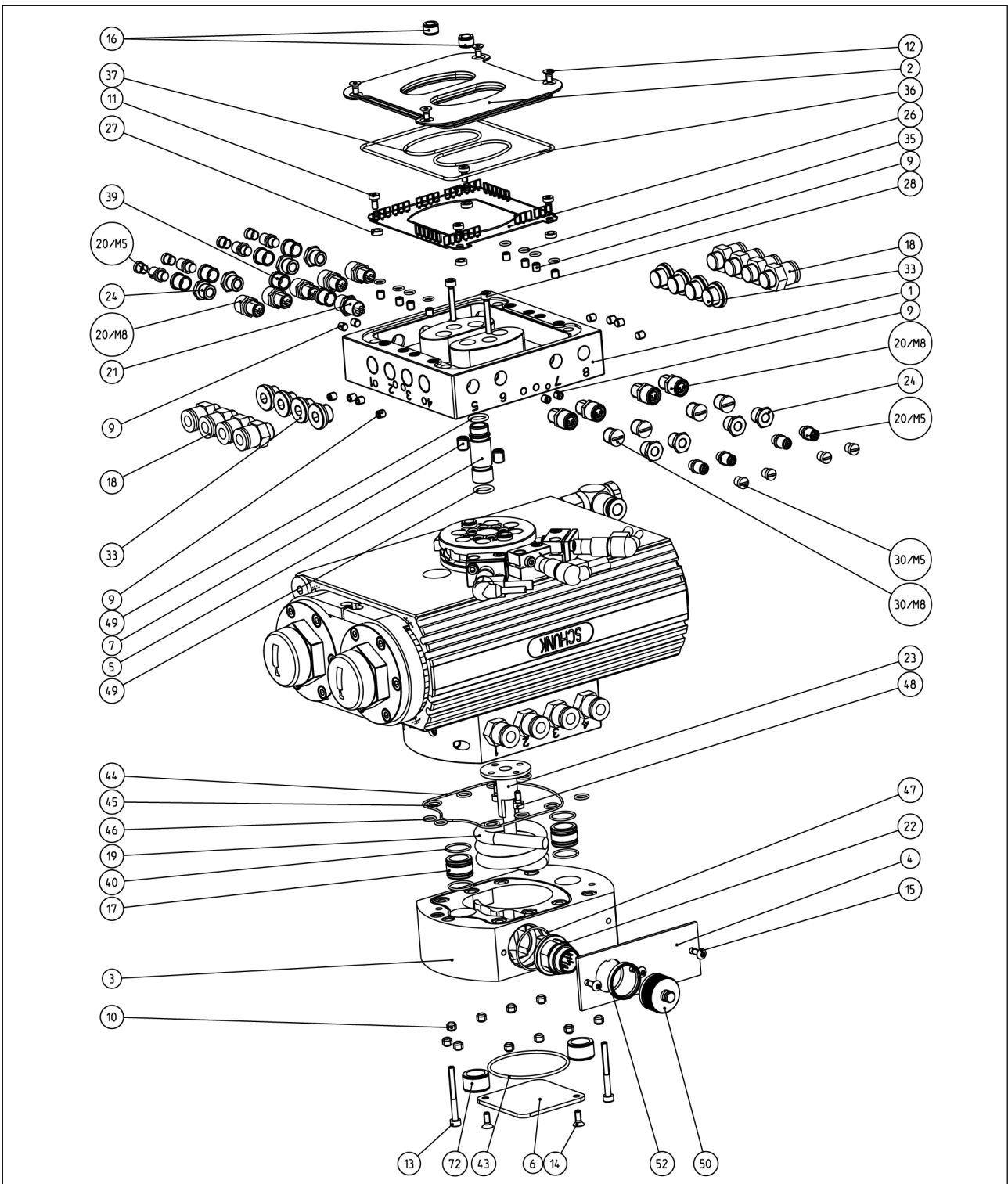

Distributor plate and electrical feed-through, size 40

8.8.2.5 Distributor plate and electrical feed-through, size 50-60

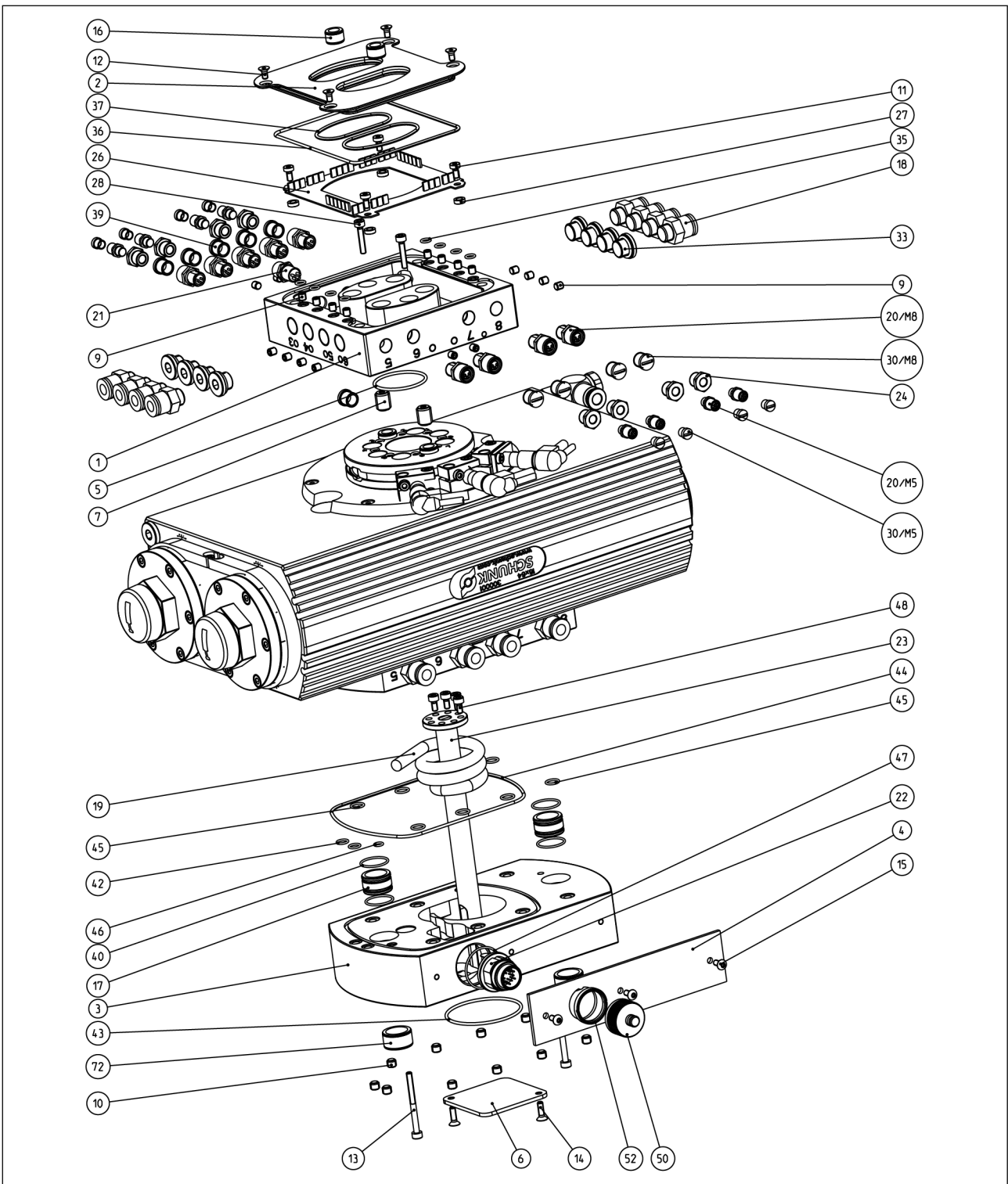

Distributor plate and electrical feed-through, size 50-60

9.1 Annex to Declaration of Incorporation

according 2006/42/EG, Annex II, No. 1 B

1. Description of the essential health and safety requirements pursuant to 2006/42/EC, Annex I that are applicable and that have been fulfilled with:

| | |
|---------------------|-----------------------|
| Product designation | Pneumatic swivel unit |
| Type designation | SRU-plus |

| | |
|---|---|
| To be provided by the System Integrator for the overall machine | ↓ |
| Fulfilled for the scope of the partly completed machine | ↓ |
| Not relevant | ↓ |

| 1.1 | Essential Requirements | | | |
|-------|--|--|---|---|
| 1.1.1 | Definitions | | X | |
| 1.1.2 | Principles of safety integration | | X | |
| 1.1.3 | Materials and products | | X | |
| 1.1.4 | Lighting | | X | |
| 1.1.5 | Design of machinery to facilitate its handling | | X | |
| 1.1.6 | Ergonomics | | X | |
| 1.1.7 | Operating positions | | | X |
| 1.1.8 | Seating | | | X |

| 1.2 | Control Systems | | | |
|---------|---|--|---|---|
| 1.2.1 | Safety and reliability of control systems | | X | |
| 1.2.2 | Control devices | | X | |
| 1.2.3 | Starting | | X | |
| 1.2.4 | Stopping | | X | |
| 1.2.4.1 | Normal stop | | X | |
| 1.2.4.2 | Operational stop | | X | |
| 1.2.4.3 | Emergency stop | | X | |
| 1.2.4.4 | Assembly of machinery | | X | |
| 1.2.5 | Selection of control or operating modes | | X | |
| 1.2.6 | Failure of the power supply | | | X |

| 1.3 | Protection against mechanical hazards | | | |
|-------|---|--|---|---|
| 1.3.1 | Risk of loss of stability | | | X |
| 1.3.2 | Risk of break-up during operation | | | X |
| 1.3.3 | Risks due to falling or ejected objects | | | X |
| 1.3.4 | Risks due to surfaces, edges or angles | | X | |
| 1.3.5 | Risks related to combined machinery | | | X |
| 1.3.6 | Risks related to variations in operating conditions | | | X |
| 1.3.7 | Risks related to moving parts | | X | |

| | | | | |
|------------|--|---|---|---|
| 1.3 | Protection against mechanical hazards | | | |
| 1.3.8 | Choice of protection against risks arising from moving parts | | | X |
| 1.3.8.1 | Moving transmission parts | | X | |
| 1.3.8.2 | Moving parts involved in the process | | | X |
| 1.3.9 | Risks of uncontrolled movements | | | X |
| 1.4 | Required characteristics of guards and protective devices | | | |
| 1.4.1 | General requirements | | | X |
| 1.4.2 | Special requirements for guards | | | X |
| 1.4.2.1 | Fixed guards | | | X |
| 1.4.2.2 | Interlocking movable guards | | | X |
| 1.4.2.3 | Adjustable guards restricting access | | | X |
| 1.4.3 | Special requirements for protective devices | | | X |
| 1.5 | Risks due to other hazards | | | |
| 1.5.1 | Electricity supply | | X | |
| 1.5.2 | Static electricity | | X | |
| 1.5.3 | Energy supply other than electricity | | X | |
| 1.5.4 | Errors of fitting | | X | |
| 1.5.5 | Extreme temperatures | | | X |
| 1.5.6 | Fire | | | X |
| 1.5.7 | Explosion | | | X |
| 1.5.8 | Noise | | | X |
| 1.5.9 | Vibrations | | | X |
| 1.5.10 | Radiation | X | | |
| 1.5.11 | External radiation | X | | |
| 1.5.12 | Laser radiation | X | | |
| 1.5.13 | Emissions of hazardous materials and substances | | | X |
| 1.5.14 | Risk of being trapped in a machine | X | | |
| 1.5.15 | Risk of slipping, tripping or falling | X | | |
| 1.5.16 | Lightning | | | X |
| 1.6 | Maintenance | | | |
| 1.6.1 | Machinery maintenance | | X | |
| 1.6.2 | Access to operating positions and servicing points | | X | |
| 1.6.3 | Isolation of energy sources | | X | |
| 1.6.4 | Operator intervention | | X | |
| 1.6.5 | Cleaning of internal parts | | X | |
| 1.7 | Information | | | |
| 1.7.1 | Information and warnings on the machinery | | X | |

Translation of original declaration of incorporation

| | | | | |
|------------|--|---|---|---|
| 1.7 | Information | | | |
| 1.7.1.1 | Information and information devices | | X | |
| 1.7.1.2 | Warning devices | | X | |
| 1.7.2 | Warning of residual risks | | X | |
| 1.7.3 | Marking of machinery | X | | |
| 1.7.4 | Instructions | X | | |
| 1.7.4.1 | General principles for the drafting of instructions | X | | |
| 1.7.4.2 | Contents of the instructions | X | | |
| 1.7.4.3 | Sales literature | X | | |
| | The classification from Annex 1 is to be supplemented from here forward. | | | |
| 2 | Supplementary essential health and safety requirements for certain categories of machinery | | | X |
| 2.1 | Foodstuffs machinery and machinery for cosmetics or pharmaceutical products | | | X |
| 2.2 | Portable hand-held and/or guided machinery | | | X |
| 2.2.1 | Portable fixing and other impact machinery | | | X |
| 2.3 | Machinery for working wood and material with similar physical characteristics | | | X |
| 3 | Supplementary essential health and safety requirements to offset hazards due to the mobility of machinery | | X | |
| 4 | Supplementary essential health and safety requirements to offset hazards due to lifting operations | | X | |
| 5 | Supplementary essential health and safety requirements for machinery intended for underground work | | | X |
| 6 | Supplementary essential health and safety requirements for machinery presenting particular hazards due to the lifting of persons | | X | |