









PRESSURE SENSORS SELECTION GUIDE

Housing	Style	Technology	Applications	Page
	PS Series For use with liquid or gaseous media.	<ul style="list-style-type: none"> High accuracy Rotatable housing Pressure up to 600 bar (8700 psi) PNP/NPN programmable 	<ul style="list-style-type: none"> Food and beverage Tooling machines Hydraulics Pneumatics Tank Level 	B2
 Nano  Pico	PK Series A cost effective sensor for switch point detection in air and gas applications.	<ul style="list-style-type: none"> Air only 2 PNP switch points picofast® connector Ranges: -29.5 to 0 in Hg, 0 to 145 psi Push button programmable 	<ul style="list-style-type: none"> Robotics Pneumatics Tooling machines 	B17
	PT Series The PT pressure transmitters offer set ranges - no adjustment needed.	<ul style="list-style-type: none"> Range up to 600 bar (8700 psi) 4-20 mA or 0-10 V analog output Female 1/4" BSPP or 1/4" NPT male fitting Stainless steel housing 	<ul style="list-style-type: none"> Food and beverage Tooling machines Hydraulics Pneumatics OEM 	B19
	PT3 Series The PT3 series has a stainless steel measuring element for refrigeration applications.	<ul style="list-style-type: none"> Stainless steel diaphragm Fully welded construction IP67 	<ul style="list-style-type: none"> Refrigeration Pumping 	B23
	PT4300 Series Class 1, division 2 hazardous area approved.	<ul style="list-style-type: none"> 316 Stainless Steel diaphragm Machined pressure element Burst pressure up to 20,000 psi 	<ul style="list-style-type: none"> Oil & gas Off-shore drilling Well head pressure 	B25
	PT4400 Series Class 1, Division 1 hazardous area approved when installed with an approved barrier.	<ul style="list-style-type: none"> Same mechanical construction as PT4300 Ranges up to 10,000 psi M12 Connector 	<ul style="list-style-type: none"> Oil & gas Gas compression 	B27
	PT4500 Series Class 1, Division 1 hazardous area approved when installed with an approved barrier.	<ul style="list-style-type: none"> IP68 Submersible Ranges from 2.5 psi to 100 psi 	<ul style="list-style-type: none"> Diesel fuel level Tank level 	B29
	Diaphragm Seals	<ul style="list-style-type: none"> Optional accessories for pressure connections 		B31

PRESSURE SENSORS – PS500

PRODUCT OVERVIEW

WHAT IS A PS500 SENSOR?

The PS500 pressure sensor is a robust pressure transmitter with display for use in hydraulic applications where constant alternating pressure levels strain the measuring cells, sealing material and the housing itself. TURCK designed its PS500 series with a ceramic measuring cell that provides over-pressure capability, drift performance and a fast reaction time.

WHY CHOOSE A PS500 SENSOR?

- High accuracy rating of +/-0.5 percent of the full scale.
- Multiple threaded connections and a unique coupling make the sensors easy to mount. Fittings available in 1/4" NPT male, 1/4" NPT female, 1/4" G male and 1/4" G female.
- Fully programmable through easy-to-operate push buttons.
- Patented media stop system prevents over-pressure.
- Selectable units of measure include PSI, Bar, millibar, inches of water, inches of mercury, millimeters of mercury, feet of water and meters of water.
- Robust, IP69k-rated housing made of stainless steel provides operational durability in harsh applications.
- 4-20mA, 2 PNP/NPN or 0-10V outputs.
- Up to 3 times overpressure.
- UL approved.

WHERE CAN I USE PS500 SENSORS?

- Air compressors
- Hydraulic clamping systems
- Bad filter detection
- Vacuum for pick-up and transfer of product
- Pneumatic systems
- Hydraulic accumulators
- Injection molding machines
- Press machines
- Automotive welding pressure
- Machine coolant
- Pump run dry



PRESSURE SENSORS – PS300

PRODUCT OVERVIEW

WHAT IS A PS300 SENSOR?

Sensing hydraulic pressure is challenging. Constant alternating pressure levels strain the measuring cells, sealing material and the housing itself. TURCK designed its PS300 series with a ceramic measuring cell that provides over-pressure capability, drift performance and a fast reaction time. The IP69k-rated housing used for this series is made of special steel, and a sealed control and display elements don't allow moisture into the device.

WHY CHOOSE A PS300 SENSOR?

- High accuracy rating of +/-0.5 percent of the full scale.
- Fittings available in 1/4" NPT male, 1/4" NPT female, 1/4" G male and 1/4" G female.
- Fully programmable through easy-to-operate pull buttons.
- Selectable units of measure include PSI, Bar, millibar, inches of water, inches of mercury, millimeters of mercury, feet of water and meters of water.
- Robust, IP69k-rated housing made of stainless steel provides operational durability in harsh applications.
- 4-20mA, 2 PNP/NPN or 0-10V outputs.
- Up to 5 times overpressure, up to 40 bar.

WHERE CAN I USE PS300 SENSORS?

- Air compressors
- Hydraulic clamping systems
- Bad filter detection
- Vacuum for pick-up and transfer of product
- Pneumatic systems
- Hydraulic accumulators
- Injection molding machines
- Press machines
- Automotive welding pressure
- Machine coolant
- Pump run dry



Pressure Instrumentation

High Accuracy Programmable Pressure Sensor Part Number Key

PS 010V - 5 03 - LI2UPN 8 X - H1141

Pressure Sensor	Connection
Nominal Pressure Range	H1141 = 4-pin male, M12x1 (eurofast®)
01VR = -1 to 0 bar gauge (-14.5 to 0 psi)	with LED
001R = 0 to 1 bar gauge (0 to 14.5 psi)	Operating Voltage
001V = -1 to 1 bar gauge (-14.5 to 14.5 psi)	8 = 15(18)...30 VDC
003V = -1 to 2.5 bar gauge (-14.5 to 36 psi)	Electrical Output
010V = -1 to 10 bar gauge (-14.5 to 145 psi)	Output 1
016V = -1 to 16 bar gauge (-14.5 to 232 psi)	2UPN = switching output
025V = -1 to 25 bar gauge (-14.5 to 362 psi)	LUUPN = switching output
040V = -1 to 40 bar gauge (-14.5 to 580 psi)	LI2UPN = switching output
100R = 0 to 100 bar gauge (0 to 1450 psi)	Output 2
250R = 0 to 250 bar gauge (0 to 3625 psi)	switching output
400R = 0 to 400 bar gauge (0 to 5800 psi)	voltage output
600R = 0 to 600 bar gauge (0 to 8700 psi)	current/switching output
001A = 0 to 1 bar absolute (0 to 14.5 psi)	
003A = 0 to 2.5 bar absolute (0 to 36 psi)	
010A = 0 to 10 bar absolute (0 to 145 psi)	
016A = 0 to 16 bar absolute (0 to 232 psi)	
025A = 0 to 25 bar absolute (0 to 362 psi)	
	Pressure Connection
	01 = G1/4" female thread
	02 = 1/4" NPT femals thread
	03 = 1/4"-18 NPT male thread
	04 = G1/4" male thread
	05 = 7/16"-20 UNF male thread
	Housing
	5 = Rotatable
	3 = IP69k

PRESSURE

TURCK

Pressure Instrumentation

PS500 Rotatable Programmable Pressure Sensors

- Great for Hydraulic and Pneumatic Applications
- IP67
- Dual Switch Point Output or Analog Current and One Switchpoint Programmable



Part Number	Operating Range		OverPressure Rating		Set Point Range	Reset Point Range	Fluid Connection	Drawing #
	Bar	PSI	Bar	PSI	PSI	PSI		
PS01VR-503-LI2UPN8X-H1141	0 to -1	0 to -14.5	3	43.5	-0.15 to -14.5	-0.07 to -14.4	1/4"-18 NPT Male	1
PS001R-503-LI2UPN8X-H1141	0 to 1	0 to 14.5	3	43.5	0.15 to 14.50	0.07 to 14.43	1/4"-18 NPT Male	1
PS001V-503-LI2UPN8X-H1141	-1 to 1	-14.5 to 14.5	3	43.5	-14.21 to 14.50	-14.36 to 14.43	1/4"-18 NPT Male	1
PS003V-503-LI2UPN8X-H1141	-1 to 2.5	-14.5 to 36.25	7	101.5	-13.99 to 36.25	-14.14 to 36.07	1/4"-18 NPT Male	1
PS010V-503-LI2UPN8X-H1141	-1 to 10	-14.5 to 145	25	362.5	-12.91 to 145	-13.05 to 144.28	1/4"-18 NPT Male	1
PS016V-503-LI2UPN8X-H1141	-1 to 16	-14.5 to 232	40	580	-12.04 to 232	-12.18 to 230.84	1/4"-18 NPT Male	1
PS025V-503-LI2UPN8X-H1141	-1 to 25	-14.5 to 362.5	65	942.5	-10.73 to 362.5	-10.88 to 360.69	1/4"-18 NPT Male	1
PS040V-503-LI2UPN8X-H1141	-1 to 40	-14.5 to 580	100	1,450	-8.55 to 580	-8.70 to 577.1	1/4"-18 NPT Male	1
PS100R-503-LI2UPN8X-H1141	0 to 100	0 to 1,450	250	3,625	14.5 to 1,450	7.25 to 1,442.75	1/4"-18 NPT Male	1
PS250R-503-LI2UPN8X-H1141	0 to 250	0 to 3,625	625	9,062.5	36.25 to 3,625	18.13 to 3,606.8	1/4"-18 NPT Male	1
PS400R-503-LI2UPN8X-H1141	0 to 400	0 to 5,800	900	13,050	58 to 5,800	29 to 5,771	1/4"-18 NPT Male	1
PS600R-503-LI2UPN8X-H1141	0 to 600	0 to 8,700	900	13,050	87 to 8,700	43.5 to 8,656.5	1/4"-18 NPT Male	1
PS01VR-505-LI2UPN8X-H1141	0 to -1	0 to -14.5	3	43.5	-0.15 to -14.5	-0.07 to -14.43	7/16"-20 UNF Male	2
PS001R-505-LI2UPN8X-H1141	0 to 1	0 to 14.5	3	43.5	0.15 to 14.5	0.07 to 14.43	7/16"-20 UNF Male	2
PS001V-505-LI2UPN8X-H1141	-1 to 1	-14.5 to 14.5	3	43.5	-14.21 to 14.5	-14.36 to 14.43	7/16"-20 UNF Male	2
PS003V-505-LI2UPN8X-H1141	-1 to 2.5	-14.5 to 36.25	7	101.5	-13.99 to 36.25	-14.14 to 36.07	7/16"-20 UNF Male	2
PS010V-505-LI2UPN8X-H1141	-1 to 10	-14.5 to 145	25	362.5	-12.91 to 145	-13.05 to 144.28	7/16"-20 UNF Male	2
PS016V-505-LI2UPN8X-H1141	-1 to 16	-14.5 to 232	40	580	-12.04 to 232	-12.18 to 230.84	7/16"-20 UNF Male	2
PS025V-505-LI2UPN8X-H1141	-1 to 25	-14.5 to 362.5	65	942.5	-10.73 to 362.5	-10.88 to 360.7	7/16"-20 UNF Male	2
PS040V-505-LI2UPN8X-H1141	-1 to 40	-14.5 to 580	100	1,450	-8.55 to 580	-8.70 to 577.1	7/16"-20 UNF Male	2
PS100R-505-LI2UPN8X-H1141	0 to 100	0 to 1,450	250	3,625	14.5 to 1,450	7.25 to 1,442	7/16"-20 UNF Male	2
PS250R-505-LI2UPN8X-H1141	0 to 250	0 to 3,625	625	9,062.5	36.25 to 3,625	18.13 to 3,606	7/16"-20 UNF Male	2
PS400R-505-LI2UPN8X-H1141	0 to 400	0 to 5,800	900	13,050	58 to 5,800	29 to 5,771	7/16"-20 UNF Male	2
PS600R-505-LI2UPN8X-H1141	0 to 600	0 to 8,700	900	13,050	87 to 8,700	43.5 to 8,656.5	7/16"-20 UNF Male	2

Pressure Instrumentation

PS500 Pressure Sensor Specifications

Electrical	
Operating Voltage	18-30 VDC
Current Consumption	50 mA
Power-On Effect	Per IEC 947-5-2
Reverse Polarity Protection	Yes
Transient Protection	EN 60947-5-2
Short-Circuit Protection	Yes
EMC Information	
EN 61000-4-2	ESD: 4 KD CK/ 8 KV AD
EN 61000-4-3	HF irradiated: 15 V/m
EN 61000-4-4	Burst: 2 KV
EN 61000-4-5	Surge: 500 V, 12
EN 61000-4-6	HF conducted: 10 V
Environmental	
Ambient Temperature	-40°to +80°C (-40°to +176°F)
Medium Temperature	-25°to +85°C (-40°to +185°F)
Enclosure Rating	Meets NEMA 4, 6, 12, 13 and IP67
Shock	50 g per IEC 68-2-27
Vibration	20 g (10-200 Hz) per IEC 68-2-6
Burst Protection	patented media stop
Materials	
Housing	Stainless Steel 303
Wetted Parts	Stainless Steel 303, Viton, Al ₂ O ₃ Ceramic
Operational	
Output	Programmable Current: . 0-20 mA, 4-20 mA, . 20-0 mA, 20-4 mA and . 1 PNP/NPN N.O./N.C. Or . 2 PNP/NPN N.O./N.C.
Switching Frequency (Discrete)	180 Hz
Switching Current	200 mA
Analog Load	500

Operational continued	
Accuracy	
Set Point Accuracy	±0.5% of Full Scale
Analog Accuracy**	±0.5% of Full Scale
Repeatability	0.5% of measuring range
Zero Shift/Span Shift	0.15% of measuring range/°C
Programmable Analog	
Analog Start Point	Programmable from 0-75% of measuring range
Analog End Point	Programmable from 25-100% of measuring range
Set Points	
Set Point Range	1% - 100% Range
Reset Point Range	.5% - 99.5% Range
Minimum Hysteresis	≥0.5% of Full Scale
Switching Delay	Switch-on and switch-off delay adjustable from 0 to 50 seconds in steps of 0.1 second
LED Function/Display	
Measuring Value	4-digit 7-segment display
Programming Status Display	LEDs indicate output status, measuring units
Display Reaction Time	Slow 600 ms update Normal 200 ms update Fast 50 ms update

** Accuracy includes linearity, repeatability and hysteresis.

Wiring Diagram

Wiring Diagram

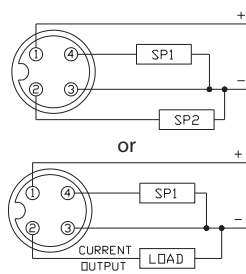

Mating Cordset:
RK 4.4T-*/S618

Drawings

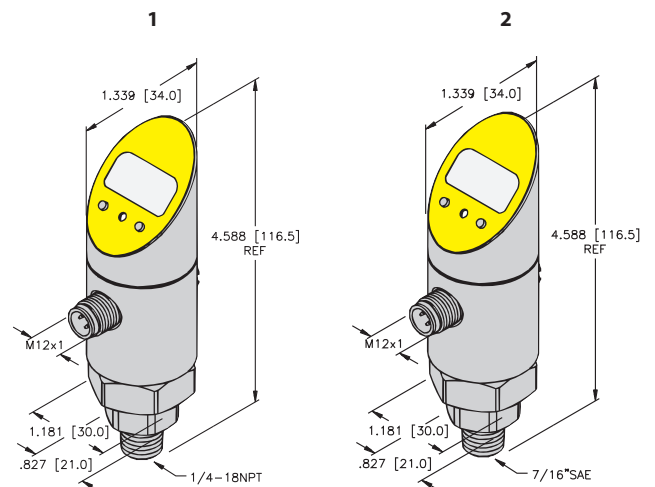

TURCK

Pressure Instrumentation

PS500 Rotatable Pressure Sensors

- Great for Hydraulic & Pneumatic Applications
- IP67
- Voltage Analog Output with One Switchpoint



Part Number	Operating Range		Overpressure Rating		Set Point Range	Reset Point Range	Fluid Connection	Drawing #
	Bar	PSI	Bar	PSI	PSI	PSI		
PS01VR-503-LUUPN8X-H1141	0 to -1	0 to -14.5	3	43.5	-0.15 to -14.5	-0.07 to -14.4	1/4"-18 NPT Male	1
PS001R-503-LUUPN8X-H1141	0 to 1	0 to 14.5	3	43.5	0.15 to 14.50	0.07 to 14.43	1/4"-18 NPT Male	1
PS001V-503-LUUPN8X-H1141	-1 to 1	-14.5 to 14.5	3	43.5	-14.21 to 14.50	-14.36 to 14.43	1/4"-18 NPT Male	1
PS003V-503-LUUPN8X-H1141	-1 to 2.5	-14.5 to 36.25	7	101.5	-13.99 to 36.25	-14.14 to 36.07	1/4"-18 NPT Male	1
PS010V-503-LUUPN8X-H1141	-1 to 10	-14.5 to 145	25	362.5	-12.91 to 145	-13.05 to 144.28	1/4"-18 NPT Male	1
PS016V-503-LUUPN8X-H1141	-1 to 16	-14.5 to 232	40	580	-12.04 to 232	-12.18 to 230.84	1/4"-18 NPT Male	1
PS025V-503-LUUPN8X-H1141	-1 to 25	-14.5 to 362.5	65	942.5	-10.73 to 362.5	-10.88 to 360.69	1/4"-18 NPT Male	1
PS040V-503-LUUPN8X-H1141	-1 to 40	-14.5 to 580	100	1,450	-8.55 to 580	-8.70 to 577.1	1/4"-18 NPT Male	1
PS100R-503-LUUPN8X-H1141	0 to 100	0 to 1,450	250	3,625	14.5 to 1,450	7.25 to 1,442.75	1/4"-18 NPT Male	1
PS250R-503-LUUPN8X-H1141	0 to 250	0 to 3,625	625	9,062.5	36.25 to 3,625	18.13 to 3,606	1/4"-18 NPT Male	1
PS400R-503-LUUPN8X-H1141	0 to 400	0 to 5,800	900	13,050	58 to 5,800	29 to 5,771	1/4"-18 NPT Male	1
PS600R-503-LUUPN8X-H1141	0 to 600	0 to 8,700	900	13,050	87 to 8,700	43.5 to 8,656.5	1/4"-18 NPT Male	1
PS01VR-505-LUUPN8X-H1141	0 to -1	0 to -14.5	3	43.5	-0.15 to -14.5	-0.07 to -14.43	7/16"-20 UNF Male	2
PS001R-505-LUUPN8X-H1141	0 to 1	0 to 14.5	3	43.5	0.15 to 14.5	0.07 to 14.43	7/16"-20 UNF Male	2
PS001V-505-LUUPN8X-H1141	-1 to 1	-14.5 to 14.5	3	43.5	-14.21 to 14.5	-14.36 to 14.43	7/16"-20 UNF Male	2
PS003V-505-LUUPN8X-H1141	-1 to 2.5	-14.5 to 36.25	7	101.5	-13.99 to 36.25	-14.14 to 36.07	7/16"-20 UNF Male	2
PS010V-505-LUUPN8X-H1141	-1 to 10	-14.5 to 145	25	362.5	-12.91 to 145	-13.05 to 144.28	7/16"-20 UNF Male	2
PS016V-505-LUUPN8X-H1141	-1 to 16	-14.5 to 232	40	580	-12.04 to 232	-12.18 to 230.84	7/16"-20 UNF Male	2
PS025V-505-LUUPN8X-H1141	-1 to 25	-14.5 to 362.5	65	942.5	-10.73 to 362.5	-10.88 to 360.69	7/16"-20 UNF Male	2
PS040V-505-LUUPN8X-H1141	-1 to 40	-14.5 to 580	100	1,450	-8.55 to 580	-8.70 to 577.1	7/16"-20 UNF Male	2
PS100R-505-LUUPN8X-H1141	0 to 100	0 to 1,450	250	3,625	14.5 to 1,450	7.25 to 1,442.75	7/16"-20 UNF Male	2
PS250R-505-LUUPN8X-H1141	0 to 250	0 to 3,625	625	9,062.5	36.25 to 3,625	18.13 to 3,606	7/16"-20 UNF Male	2
PS400R-505-LUUPN8X-H1141	0 to 400	0 to 5,800	900	13,050	58 to 5,800	29 to 5,771	7/16"-20 UNF Male	2
PS600R-505-LUUPN8X-H1141	0 to 600	0 to 8,700	900	13,050	87 to 8,700	43.5 to 8,656.5	7/16"-20 UNF Male	2

Pressure Instrumentation

PS500 Pressure Sensor Specifications

Electrical	
Operating Voltage	18-30 VDC
Current Consumption	50 mA
Power-On Effect	Per IEC 947-5-2
Reverse Polarity Protection	Yes
Transient Protection	EN 60947-5-2
Short-Circuit Protection	Yes
EMC Information	
EN 61000-4-2	ESD: 4 KD CK/ 8 KV AD
EN 61000-4-3	HF irradiated: 15 V/m
EN 61000-4-4	Burst: 2 KV
EN 61000-4-5	Surge: 500 V, 12
EN 61000-4-6	HF conducted: 10 V
Environmental	
Ambient Temperature	-40°to +80°C (-40°to +176°F)
Medium Temperature	-25°to +85°C (-40°to +185°F)
Enclosure Rating	Meets NEMA 4, 6, 12, 13 and IP67
Shock	50 g per IEC 68-2-27
Vibration	20 g (10-200 Hz) per IEC 68-2-6
Burst Protection	patented media stop
Materials	
Housing	Stainless Steel 303
Wetted Parts	Stainless Steel 303, Viton Al ₂ O ₃ Ceramic
Operational	
Output	Programmable Current: . 0-10 V, 1-6 V, 0-5 V . 10-0 V, 6- 1 V, 5-0 V and . 1 PNP/NPN N.O./N.C. Or . 2 PNP/NPN N.O./N.C.
Switching Frequency (Discrete)	180 Hz
Switching Current	200 mA
Analog Load	500

Operational continued	
Accuracy	
Set Point Accuracy	±0.5% of Full Scale
Analog Accuracy**	±0.5% of Full Scale
Repeatability	0.5% of measuring range
Zero Shift/Span Shift	0.15% of measuring range/°C
Programmable Analog	
Analog Start Point	Programmable from 0-75% of measuring range
Analog End Point	Programmable from 25-100% of measuring range
Set Points	
Set Point Range	1% - 100% Range
Reset Point Range	.5% - 99.5% Range
Minimum Hysteresis	≥0.5% of Full Scale
Switching Delay	Switch-on and switch-off delay adjustable from 0 to 50 seconds in steps of 0.1 second
LED Function/Display	
Measuring Value	4-digit 7-segment display
Programming Status Display	LEDs indicate output status and selected measuring units
Display Reaction Time	Slow 600 ms update Normal 200 ms update Fast 50 ms update

** Accuracy includes linearity, repeatability and hysteresis.

PRESSURE

Wiring Diagram

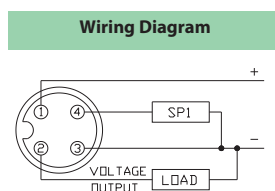

Mating Cordset:
RK 4.4T-*/S618

Drawings

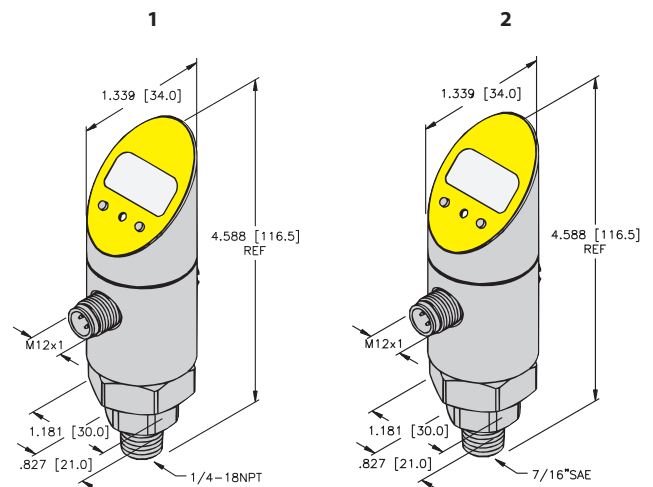

TURCK

Pressure Instrumentation

PS500 Rotatable Programmable Pressure Sensors

- Great for Hydraulic & Pneumatic Application
- IP67
- Dual Switch points



Part Number	Operating Range		Overpressure Rating		Set Point Range	Reset Point Range	Fluid Connection	Drawing #
	Bar	PSI	Bar	PSI	PSI	PSI		
PS01VR-503-2UPN8X-H1141	0 to -1	0 to -14.5	3	43.5	-0.15 to -14.5	-0.07 to -14.4	1/4"-18 NPT Male	1
PS001R-503-2UPN8X-H1141	0 to 1	0 to 14.5	3	43.5	0.15 to 14.50	0.07 to 14.43	1/4"-18 NPT Male	1
PS001V-503-2UPN8X-H1141	-1 to 1	-14.5 to 14.5	3	43.5	-14.21 to 14.50	-14.36 to 14.43	1/4"-18 NPT Male	1
PS003V-503-2UPN8X-H1141	-1 to 2.5	-14.5 to 36.25	7	101.5	-13.99 to 36.25	-14.14 to 36.07	1/4"-18 NPT Male	1
PS010V-503-2UPN8X-H1141	-1 to 10	-14.5 to 145	25	362.5	-12.91 to 145	-13.05 to 144.28	1/4"-18 NPT Male	1
PS016V-503-2UPN8X-H1141	-1 to 16	-14.5 to 232	40	580	-12.04 to 232	-12.18 to 230.84	1/4"-18 NPT Male	1
PS025V-503-2UPN8X-H1141	-1 to 25	-14.5 to 362.5	65	942.5	-10.73 to 362.5	-10.88 to 360.69	1/4"-18 NPT Male	1
PS040V-503-2UPN8X-H1141	-1 to 40	-14.5 to 580	100	1,450	-8.55 to 580	-8.70 to 577.1	1/4"-18 NPT Male	1
PS100R-503-2UPN8X-H1141	0 to 100	0 to 1,450	250	3,625	14.5 to 1,450	7.25 to 1,442.75	1/4"-18 NPT Male	1
PS250R-503-2UPN8X-H1141	0 to 250	0 to 3,625	625	9,062.5	36.25 to 3,625	18.13 to 3,606	1/4"-18 NPT Male	1
PS400R-503-2UPN8X-H1141	0 to 400	0 to 5,800	900	13,050	58 to 5,800	29 to 5,771	1/4"-18 NPT Male	1
PS600R-503-2UPN8X-H1141	0 to 600	0 to 8,700	900	13,050	87 to 8,700	43.5 to 8,656.5	1/4"-18 NPT Male	1
PS01VR-505-2UPN8X-H1141	0 to -1	0 to -14.5	3	43.5	-0.15 to -14.5	-0.07 to -14.43	7/16"-20 UNF Male	2
PS001R-505-2UPN8X-H1141	0 to 1	0 to 14.5	3	43.5	0.15 to 14.5	0.07 to 14.43	7/16"-20 UNF Male	2
PS001V-505-2UPN8X-H1141	-1 to 1	-14.5 to 14.5	3	43.5	-14.21 to 14.5	-14.36 to 14.43	7/16"-20 UNF Male	2
PS003V-505-2UPN8X-H1141	-1 to 2.5	-14.5 to 36.25	7	101.5	-13.99 to 36.25	-14.14 to 36.07	7/16"-20 UNF Male	2
PS010V-505-2UPN8X-H1141	-1 to 10	-14.5 to 145	25	362.5	-12.91 to 145	-13.05 to 144.28	7/16"-20 UNF Male	2
PS016V-505-2UPN8X-H1141	-1 to 16	-14.5 to 232	40	580	-12.04 to 232	-12.18 to 230.84	7/16"-20 UNF Male	2
PS025V-505-2UPN8X-H1141	-1 to 25	-14.5 to 362.5	65	942.5	-10.73 to 362.5	-10.88 to 360.69	7/16"-20 UNF Male	2
PS040V-505-2UPN8X-H1141	-1 to 40	-14.5 to 580	100	1,450	-8.55 to 580	-8.70 to 577.1	7/16"-20 UNF Male	2
PS100R-505-2UPN8X-H1141	0 to 100	0 to 1,450	250	3,625	14.5 to 1,450	7.25 to 1,442.75	7/16"-20 UNF Male	2
PS250R-505-2UPN8X-H1141	0 to 250	0 to 3,625	625	9,062.5	36.25 to 3,625	18.13 to 3,606	7/16"-20 UNF Male	2
PS400R-505-2UPN8X-H1141	0 to 400	0 to 5,800	900	13,050	58 to 5,800	29 to 5,771	7/16"-20 UNF Male	2
PS600R-505-2UPN8X-H1141	0 to 600	0 to 8,700	900	13,050	87 to 8,700	43.5 to 8,656.5	7/16"-20 UNF Male	2

Pressure Instrumentation

PS500 Programmable Pressure Sensor Specifications

Electrical	
Operating Voltage	15-30 VDC
Current Consumption	50 mA
Power-On Effect	Per IEC 947-5-2
Reverse Polarity Protection	Yes
Transient Protection	EN 60947-5-2
Short-Circuit Protection	Yes
EMC Information	
EN 61000-4-2	ESD: 4 KD CK/ 8 KV AD
EN 61000-4-3	HF irradiated: 15 V/m
EN 61000-4-4	Burst: 2 KV
EN 61000-4-5	Surge: 500 V, 12
EN 61000-4-6	HF conducted: 10 V
Environmental	
Ambient Temperature	-40°to +80°C (-40°to +176°F)
Medium Temperature	-25°to +85°C (-40°to +185°F)
Enclosure Rating	Meets NEMA 4, 6, 12, 13 and IP67
Shock	50 g per IEC 68-2-27
Vibration	20 g (10-200 Hz) per IEC 68-2-6
Burst Protection	patented media stop
Materials	
Housing	Stainless Steel 303
Wetted Parts	Stainless Steel 303, Viton Al ₂ O ₃ Ceramic
Operational	
Output	. 2 PNP/NPN N.O./N.C.
Switching Frequency	180 Hz
Switching Current	200 mA

Operational continued	
Accuracy	
Set Point Accuracy	±0.5% Of Full Scale
Repeatability	0.5% of measuring range
Zero Shift/Span Shift	0.15% of measuring range/°C
Set Points	
Set Point Range	1% - 100% Range
Reset Point Range	.5% - 99.5% Range
Minimum Hysteresis	≥0.5% Of Full Scale
Switching Delay	Switch-on and switch-off delay adjustable from 0 to 50 seconds in steps of 0.1 second
LED Function/Display	
Measuring Value	4-digit 7-segment display Programming
Programming Status Display	LEDs indicate output status and selected measuring units
Display Reaction Time	Slow 600 ms update Normal 200 ms update Fast 50 ms update

PRESSURE

Wiring Diagram

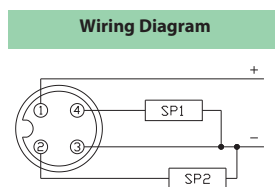

Mating Cordset:
RK 4.4T-*

Drawings

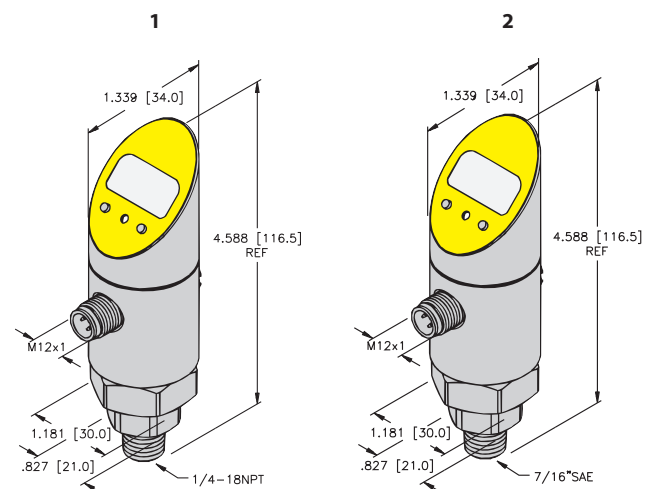

TURCK

Pressure Instrumentation

PS300 Programmable Pressure Sensors

- Great for Hydraulic and Pneumatic Applications
- IP69K
- Dual Switch Point or Analog Current and One Switch Point Output

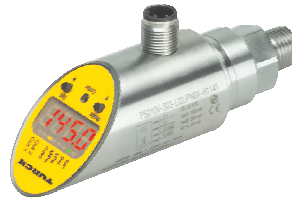

Part Number	Operating Range		Overpressure Rating		Set Point Range	Reset Point Range	Fluid Connection	Drawing #
	Bar	PSI	Bar	PSI	PSI	PSI		
PS01VR-303-LI2UPN8X-H1141	-1 to 0	-14.5 to 0	5.5	79.7	-0.15 to -14.5	-0.07 to -14.4	1/4"-18 NPT Male	1
PS001R-303-LI2UPN8X-H1141	0 to 1	0 to 14.5	5.5	79.7	0.15 to 14.5	0.07 to 14.43	1/4"-18 NPT Male	1
PS001V-303-LI2UPN8X-H1141	-1 to 1	-14.5 to 14.5	5.5	79.7	-14.21 to 14.5	-14.36 to 14.43	1/4"-18 NPT Male	1
PS003V-303-LI2UPN8X-H1141	-1 to 2.5	-14.5 to 36.25	12	101.5	-13.99 to 36.25	-14.14 to 36.07	1/4"-18 NPT Male	1
PS010V-303-LI2UPN8X-H1141	-1 to 10	-14.5 to 145	50	362.5	-12.91 to 145	-13.05 to 144.28	1/4"-18 NPT Male	1
PS016V-303-LI2UPN8X-H1141	-1 to 16	-14.5 to 232	80	580	-12.04 to 232	-12.18 to 230.84	1/4"-18 NPT Male	1
PS025V-303-LI2UPN8X-H1141	-1 to 25	-14.5 to 362.5	120	942.5	-10.73 to 362.5	-10.88 to 360.69	1/4"-18 NPT Male	1
PS040V-303-LI2UPN8X-H1141	-1 to 40	-14.5 to 580	200	1,450	-8.55 to 580	-8.70 to 577.1	1/4"-18 NPT Male	1
PS100R-303-LI2UPN8X-H1141	0 to 100	0 to 1,450	450	3,625	14.5 to 1,450	7.25 to 1,442.75	1/4"-18 NPT Male	1
PS250R-303-LI2UPN8X-H1141	0 to 250	0 to 3,625	800	9,062.5	36.25 to 3,625	18.13 to 3,606	1/4"-18 NPT Male	1
PS400R-303-LI2UPN8X-H1141	0 to 400	0 to 5,800	900	13,050	58 to 5,800	29 to 5,771	1/4"-18 NPT Male	1
PS600R-303-LI2UPN8X-H1141	0 to 600	0 to 8,700	900	13,050	87 to 8,700	43.5 to 8,656.5	1/4"-18 NPT Male	1
PS01VR-301-LI2UPN8X-H1141	-1 to 0	-14.5 to 0	5.5	79.7	-0.15 to -14.5	-0.07 to -14.4	G1/4" Female	2
PS001R-301-LI2UPN8X-H1141	0 to 1	0 to 14.5	5.5	79.7	0.15 to 14.5	0.07 to 14.43	G1/4" Female	2
PS001V-301-LI2UPN8X-H1141	-1 to 1	-14.5 to 14.5	5.5	79.7	-14.21 to 14.5	-14.36 to 14.43	G1/4" Female	2
PS003V-301-LI2UPN8X-H1141	-1 to 2.5	-14.5 to 36.25	12	101.5	-13.99 to 36.25	-14.14 to 36.07	G1/4" Female	2
PS010V-301-LI2UPN8X-H1141	-1 to 10	-14.5 to 145	50	362.5	-12.91 to 145	-13.05 to 144.28	G1/4" Female	2
PS016V-301-LI2UPN8X-H1141	-1 to 16	-14.5 to 232	80	580	-12.04 to 232	-12.18 to 230.84	G1/4" Female	2
PS025V-301-LI2UPN8X-H1141	-1 to 25	-14.5 to 362.5	120	942.5	-10.73 to 362.5	-10.88 to 360.69	G1/4" Female	2
PS040V-301-LI2UPN8X-H1141	-1 to 40	-14.5 to 580	200	1,450	-8.55 to 580	-8.70 to 577.1	G1/4" Female	2
PS100R-301-LI2UPN8X-H1141	0 to 100	0 to 1,450	450	3,625	14.5 to 1,450	7.25 to 1,442.75	G1/4" Female	2
PS250R-301-LI2UPN8X-H1141	0 to 250	0 to 3,625	800	9,062.5	36.25 to 3,625	18.13 to 3,606	G1/4" Female	2
PS400R-301-LI2UPN8X-H1141	0 to 400	0 to 5,800	900	13,050	58 to 5,800	29 to 5,771	G1/4" Female	2
PS600R-301-LI2UPN8X-H1141	0 to 600	0 to 8,700	900	13,050	87 to 8,700	43.5 to 8,656.5	G1/4" Female	2

Pressure Instrumentation

PS300 Programmable Pressure Sensor Specifications

Electrical	
Operating Voltage	18-30 VDC
Current Consumption	50 mA
Power-On Effect	Per IEC 947-5-2
Reverse Polarity Protection	Yes
Transient Protection	EN 60947-5-2
Short-Circuit Protection	Yes
EMC Information	
EN 61000-4-2	ESD: 4 KD CK/ 8 KV AD
EN 61000-4-3	HF irradiated: 15 V/m
EN 61000-4-4	Burst: 2 KV
EN 61000-4-5	Surge: 500 V, 12
EN 61000-4-6	HF conducted: 10 V
Environmental	
Ambient Temperature	-40°to +80°C (-40°to +176°F)
Medium Temperature	-25°to +85°C (-40°to +185°F)
Enclosure Rating	IP69K
Shock	50 g per IEC 68-2-27
Vibration	20 g (10-200 Hz) per IEC 68-2-6
Burst Protection	patented media stop
Materials	
Housing	Stainless Steel 303
Wetted Parts	Stainless Steel 303, FPM o-ring Al ₂ O ₃ Ceramic transducer
Operational	
Output	Programmable Current: 0-20 mA, 4-20 mA, 20-0 mA, 20-4 mA and 1 PNP/NPN N.O./N.C. Or 2 PNP/NPN N.O./N.C.
Switching Frequency	180 Hz
Switching Current	200 mA
Analog Load	500

Operational continued	
Accuracy	
Set Point Accuracy	±0.5% of Full Scale
Analog Accuracy	±0.5% of Full Scale
Response time	<3 ms
Repeatability	0.5% of measuring range
Zero Shift/Span Shift	0.15% of measuring range/°C
Programmable Analog	
Analog Start Point	Programmable from 0-75% of measuring range
Analog End Point	Programmable from 25-100% of measuring range
Set Points	
Set Point Range	1% - 100% Range
Reset Point Range	.5% - 99.5% Range
Minimum Hysteresis	0.5% of Full Scale
Switching Delay	Switch-on and switch-off delay adjustable from 0 to 50 seconds in steps of 0.1 second
LED Function/Display	
Measuring Value	4-digit 7-segment display
Programming Status Display	LEDs indicate output status and selected measuring units
Display Reaction Time	Slow 600 ms update Normal 200 ms update Fast 50 ms update
I/O Link Parameters	
Communication	Specified according to Version 1.0
Parameterization	FDT/DTM
Transmission Physics	3-wire physics
Transmission Rate	COM2/38.4 kbps
Process Data Width	16 bit
Measured Value	14 bit
Switch Point	2 bit
Frame Type	2-3

Wiring Diagram Drawings

Wiring Diagram

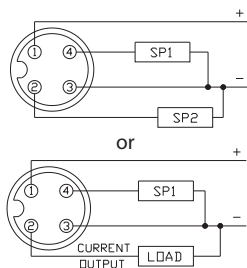

Mating Cordset:
RK 4.4T-*/S618

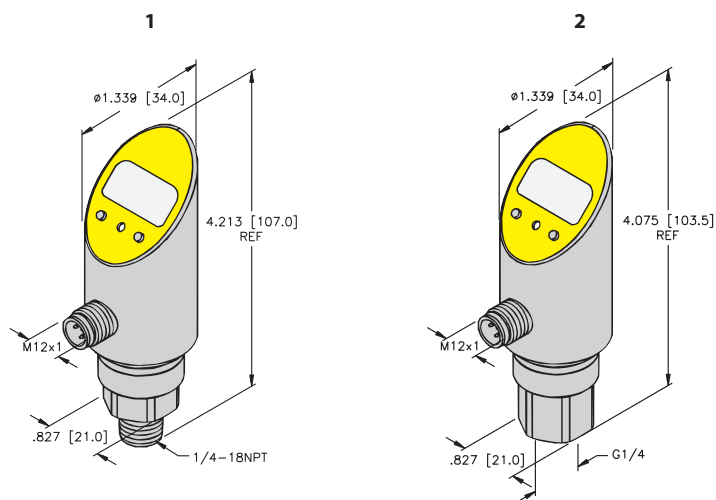

TURCK

Pressure Instrumentation

PS300 Programmable Pressure Sensors

- Great for Hydraulic and Pneumatic Applications
- IP69K
- Analog Voltage and One Switch Point Output



Part Number	Operating Range		OverPressure Rating		Set Point Range	Reset Point Range	Fluid Connection	Drawing #
	Bar	PSI	Bar	PSI	PSI	PSI		
PS01VR-303-LUUPN8X-H1141	-1 to 0	-14.5 to 0	5.5	79.7	-0.15 to -14.5	-0.07 to -14.4	1/4"-18 NPT Male	1
PS001R-303-LUUPN8X-H1141	0 to 1	0 to 14.5	5.5	79.7	0.15 to 14.5	0.07 to 14.43	1/4"-18 NPT Male	1
PS001V-303-LUUPN8X-H1141	-1 to 1	-14.5 to 14.5	5.5	79.7	-14.21 to 14.5	-14.36 to 14.43	1/4"-18 NPT Male	1
PS003V-303-LUUPN8X-H1141	-1 to 2.5	-14.5 to 36.25	12	101.5	-13.99 to 36.25	-14.14 to 36.07	1/4"-18 NPT Male	1
PS010V-303-LUUPN8X-H1141	-1 to 10	-14.5 to 145	50	362.5	-12.91 to 145	-13.05 to 144.28	1/4"-18 NPT Male	1
PS016V-303-LUUPN8X-H1141	-1 to 16	-14.5 to 232	80	580	-12.04 to 232	-12.18 to 230.84	1/4"-18 NPT Male	1
PS025V-303-LUUPN8X-H1141	-1 to 25	-14.5 to 362.5	120	942.5	-10.73 to 362.5	-10.88 to 360.69	1/4"-18 NPT Male	1
PS040V-303-LUUPN8X-H1141	-1 to 40	-14.5 to 580	200	1,450	-8.55 to 580	-8.70 to 577.1	1/4"-18 NPT Male	1
PS100R-303-LUUPN8X-H1141	0 to 100	0 to 1,450	450	3,625	14.5 to 1,450	7.25 to 1,442.75	1/4"-18 NPT Male	1
PS250R-303-LUUPN8X-H1141	0 to 250	0 to 3,625	800	9,062.5	36.25 to 3,625	18.13 to 3,606.88	1/4"-18 NPT Male	1
PS400R-303-LUUPN8X-H1141	0 to 400	0 to 5,800	900	13,050	58 to 5,800	29 to 5,771	1/4"-18 NPT Male	1
PS600R-303-LUUPN8X-H1141	0 to 600	0 to 8,700	900	13,050	87 to 8,700	43.5 to 8,656.5	1/4"-18 NPT Male	1
PS01VR-301-LUUPN8X-H1141	-1 to 0	-14.5 to 0	5.5	79.7	-0.15 to -14.5	-0.07 to -14.4	G1/4" Female	2
PS001R-301-LUUPN8X-H1141	0 to 1	0 to 14.5	5.5	79.7	0.15 to 14.5	0.07 to 14.43	G1/4" Female	2
PS001V-301-LUUPN8X-H1141	-1 to 1	-14.5 to 14.5	5.5	79.7	-14.21 to 14.5	-14.36 to 14.43	G1/4" Female	2
PS003V-301-LUUPN8X-H1141	-1 to 2.5	-14.5 to 36.25	12	101.5	-13.99 to 36.25	-14.14 to 36.07	G1/4" Female	2
PS010V-301-LUUPN8X-H1141	-1 to 10	-14.5 to 145	50	362.5	-12.91 to 145	-13.05 to 144.28	G1/4" Female	2
PS016V-301-LUUPN8X-H1141	-1 to 16	-14.5 to 232	80	580	-12.04 to 232	-12.18 to 230.84	G1/4" Female	2
PS025V-301-LUUPN8X-H1141	-1 to 25	-14.5 to 362.5	120	942.5	-10.73 to 362.5	-10.88 to 360.69	G1/4" Female	2
PS040V-301-LUUPN8X-H1141	-1 to 40	-14.5 to 580	200	1,450	-8.55 to 580	-8.70 to 577.1	G1/4" Female	2
PS100R-301-LUUPN8X-H1141	0 to 100	0 to 1,450	450	3,625	14.5 to 1,450	7.25 to 1,442.75	G1/4" Female	2
PS250R-301-LUUPN8X-H1141	0 to 250	0 to 3,625	800	9,062.5	36.25 to 3,625	18.13 to 3,606	G1/4" Female	2
PS400R-301-LUUPN8X-H1141	0 to 400	0 to 5,800	900	13,050	58 to 5,800	29 to 5,771	G1/4" Female	2
PS600R-301-LUUPN8X-H1141	0 to 600	0 to 8,700	900	13,050	87 to 8,700	43.5 to 8,656.5	G1/4" Female	2

Pressure Instrumentation

PRESSURE

PS300 Programmable Pressure Sensor Specifications

Electrical	
Operating Voltage	18-30 VDC
Current Consumption	50 mA
Power-On Effect	Per IEC 947-5-2
Reverse Polarity Protection	Yes
Transient Protection	EN 60947-5-2
Short-Circuit Protection	Yes
EMC Information	
EN 61000-4-2	ESD: 4 KD CK/ 8 KV AD
EN 61000-4-3	HF irradiated: 15 V/m
EN 61000-4-4	Burst: 2 KV
EN 61000-4-5	Surge: 500 V, 12
EN 61000-4-6	HF conducted: 10 V
Environmental	
Ambient Temperature	-40°to +80°C (-40°to +176°F)
Medium Temperature	-25°to +85°C (-40°to +185°F)
Enclosure Rating	IP69K
Shock	50 g per IEC 68-2-27
Vibration	20 g (10-200 Hz) per IEC 68-2-6
Burst Protection	patented media stop
Materials	
Housing	Stainless Steel 303
Wetted Parts	Stainless Steel 303, FPM o-ring Al ₂ O ₃ Ceramic transducer
Operational	
Output	Programmable Current: . 0-10 V, 1-6 V, 0-5 V . 10-0 V, 6- 1 V, 5-0 V and . 1 PNP/NPN N.O./N.C. Or . 2 PNP/NPN N.O./N.C.
Switching Frequency	180 Hz
Switching Current	200 mA
Analog Load	500

Operational continued	
Accuracy	
Set Point Accuracy	±0.5% of Full Scale
Analog Accuracy**	±0.5% of Full Scale
Response time	<3 ms
Repeatability	0.5% of measuring range
Zero Shift/Span Shift	0.15% of measuring range/°C
Programmable Analog	
Analog Start Point	Programmable from 0-75% of measuring range
Analog End Point	Programmable from 25-100% of measuring range
Set Points	
Set Point Range	1% - 100% Range
Reset Point Range	.5% - 99.5% Range
Minimum Hysteresis	0.5% of Full Scale
Switching Delay	Switch-on and switch-off delay adjustable from 0 to 50 seconds in steps of 0.1 second
LED Function/Display	
Measuring Value	4-digit 7-segment display
Programming Status Display	LEDs indicate output status and selected measuring units
Display Reaction Time	Slow 600 ms update Normal 200 ms update Fast 50 ms update
I/O Link Parameters	
Communication	Specified according to Version 1.0
Parameterization	FDT/DTM
Transmission Physics	3-wire physics
Transmission Rate	COM2/38.4 kbps
Process Data Width	16 bit
Measured Value	14 bit
Switch Point	2 bit
Frame Type	2-3

Wiring Diagram
Drawings

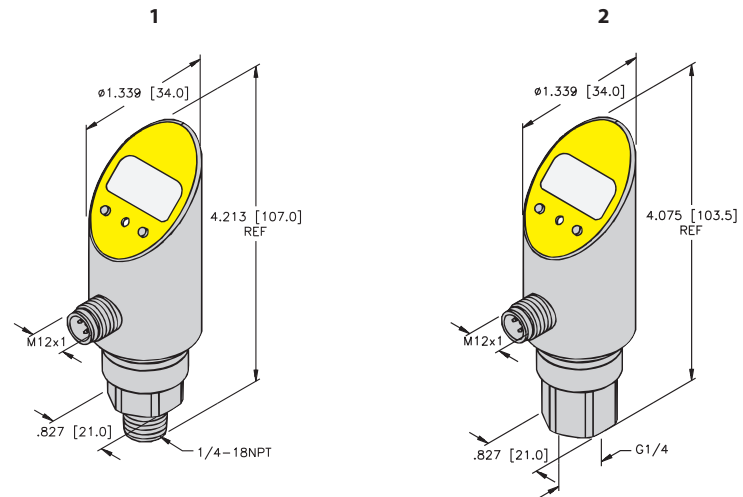
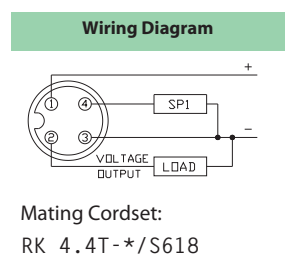

TURCK

Pressure Instrumentation

PS300 Programmable Pressure Sensors

- Great for Hydraulic and Pneumatic Applications
- IP69K
- Dual Switch Point Output



Part Number	Operating Range		Overpressure Rating		Set Point Range	Reset Point Range	Fluid Connection	Drawing #
	Bar	PSI	Bar	PSI	PSI	PSI		
PS01VR-303-2UPN8X-H1141	-1 to 0	-14.5 to 0	5.5	79.7	-0.15 to -14.5	-0.07 to -14.4	1/4"-18 NPT Male	1
PS001R-303-2UPN8X-H1141	0 to 1	0 to 14.5	5.5	79.7	0.15 to 14.5	0.07 to 14.43	1/4"-18 NPT Male	1
PS001V-303-2UPN8X-H1141	-1 to 1	-14.5 to 14.5	5.5	79.7	-14.21 to 14.5	-14.36 to 14.43	1/4"-18 NPT Male	1
PS003V-303-2UPN8X-H1141	-1 to 2.5	-14.5 to 36.25	12	101.5	-13.99 to 36.25	-14.14 to 36.07	1/4"-18 NPT Male	1
PS010V-303-2UPN8X-H1141	-1 to 10	-14.5 to 145	50	362.5	-12.91 to 145	-13.05 to 144.28	1/4"-18 NPT Male	1
PS016V-303-2UPN8X-H1141	-1 to 16	-14.5 to 232	80	580	-12.04 to 232	-12.18 to 230.84	1/4"-18 NPT Male	1
PS025V-303-2UPN8X-H1141	-1 to 25	-14.5 to 362.5	120	942.5	-10.73 to 362.5	-10.88 to 360.69	1/4"-18 NPT Male	1
PS040V-303-2UPN8X-H1141	-1 to 40	-14.5 to 580	200	1,450	-8.55 to 580	-8.70 to 577.1	1/4"-18 NPT Male	1
PS100R-303-2UPN8X-H1141	0 to 100	0 to 1,450	450	3,625	14.5 to 1,450	7.25 to 1,442.75	1/4"-18 NPT Male	1
PS250R-303-2UPN8X-H1141	0 to 250	0 to 3,625	800	9,062.5	36.25 to 3,625	18.13 to 3,606	1/4"-18 NPT Male	1
PS400R-303-2UPN8X-H1141	0 to 400	0 to 5,800	900	13,050	58 to 5,800	29 to 5,771	1/4"-18 NPT Male	1
PS600R-303-2UPN8X-H1141	0 to 600	0 to 8,700	900	13,050	87 to 8,700	43.5 to 8,656.5	1/4"-18 NPT Male	1
PS01VR-301-2UPN8X-H1141	-1 to 0	-14.5 to 0	5.5	79.7	-0.15 to -14.5	-0.07 to -14.4	G1/4" Female	2
PS001R-301-2UPN8X-H1141	0 to 1	0 to 14.5	5.5	79.7	0.15 to 14.5	0.07 to 14.43	G1/4" Female	2
PS001V-301-2UPN8X-H1141	-1 to 1	-14.5 to 14.5	5.5	79.7	-14.21 to 14.5	-14.36 to 14.43	G1/4" Female	2
PS003V-301-2UPN8X-H1141	-1 to 2.5	-14.5 to 36.25	12	101.5	-13.99 to 36.25	-14.14 to 36.07	G1/4" Female	2
PS010V-301-2UPN8X-H1141	-1 to 10	-14.5 to 145	50	362.5	-12.91 to 145	-13.05 to 144.28	G1/4" Female	2
PS016V-301-2UPN8X-H1141	-1 to 16	-14.5 to 232	80	580	-12.04 to 232	-12.18 to 230.84	G1/4" Female	2
PS025V-301-2UPN8X-H1141	-1 to 25	-14.5 to 362.5	120	942.5	-10.73 to 362.5	-10.88 to 360.69	G1/4" Female	2
PS040V-301-2UPN8X-H1141	-1 to 40	-14.5 to 580	200	1,450	-8.55 to 580	-8.70 to 577.1	G1/4" Female	2
PS100R-301-2UPN8X-H1141	0 to 100	0 to 1,450	450	3,625	14.5 to 1,450	7.25 to 1,442.75	G1/4" Female	2
PS250R-301-2UPN8X-H1141	0 to 250	0 to 3,625	800	9,062.5	36.25 to 3,625	18.13 to 3,606	G1/4" Female	2
PS400R-301-2UPN8X-H1141	0 to 400	0 to 5,800	900	13,050	58 to 5,800	29 to 5,771	G1/4" Female	2
PS600R-301-2UPN8X-H1141	0 to 600	0 to 8,700	900	13,050	87 to 8,700	43.5 to 8,656.5	G1/4" Female	2

Pressure Instrumentation

PS300 Programmable Pressure Sensor Specifications

Electrical	
Operating Voltage	15-30 VDC
Current Consumption	50 mA
Power-On Effect	Per IEC 947-5-2
Reverse Polarity Protection	Yes
Transient Protection	EN 60947-5-2
Short-Circuit Protection	Yes
EMC Information	
EN 61000-4-2	ESD: 4 KD CK/ 8 KV AD
EN 61000-4-3	HF irradiated: 15 V/m
EN 61000-4-4	Burst: 2 KV
EN 61000-4-5	Surge: 500 V, 12
EN 61000-4-6	HF conducted: 10 V
Environmental	
Ambient Temperature	-40°to +80°C (-40°to +176°F)
Medium Temperature	-25°to +85°C (-40°to +185°F)
Enclosure Rating	IP69K
Shock	50 g per IEC 68-2-27
Vibration	20 g (10-200 Hz) per IEC 68-2-6
Burst Protection	patented media stop
Materials	
Housing	Stainless Steel 303
Wetted Parts	Stainless Steel 303, FPM o-ring Al ₂ O ₃ Ceramic transducer
Operational	
Output	. 2 PNP/NPN N.O./N.C.
Switching Frequency	180 Hz
Switching Current	200 mA

Operational continued	
Accuracy	
Set Point Accuracy	±0.5% Of Full Scale
Analog Accuracy**	±0.5% Of Full Scale
Response time	<3 ms
Repeatability	0.5% of measuring range
Zero Shift/Span Shift	0.15% of measuring range/°C
Set Points	
Set Point Range	1% - 100% Range
Reset Point Range	.5% - 99.5% Range
Minimum Hysteresis	0.5%
Switching Delay	Switch-on and switch-off delay adjustable from 0 to 50 seconds in steps of 0.1 second
LED Function/Display	
Measuring Value/	4-digit 7-segment display
Programming Status Display	LEDs indicate output status and selected measuring units
Display Reaction Time	Slow 600 ms update Normal 200 ms update Fast 50 ms update
I/O Link Parameters	
Communication	Specified according to Version 1.0
Parameterization	FDT/DTM
Transmission Physics	3-wire physics
Transmission Rate	COM2/38.4 kbps
Process Data Width	16 bit
Measured Value	14 bit
Switch Point	2 bit
Frame Type	2-3

PRESSURE

Wiring Diagram

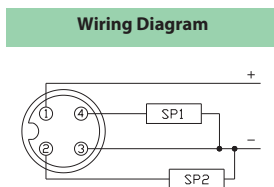

Mating Cordset:
RK 4.4T-*

Drawings

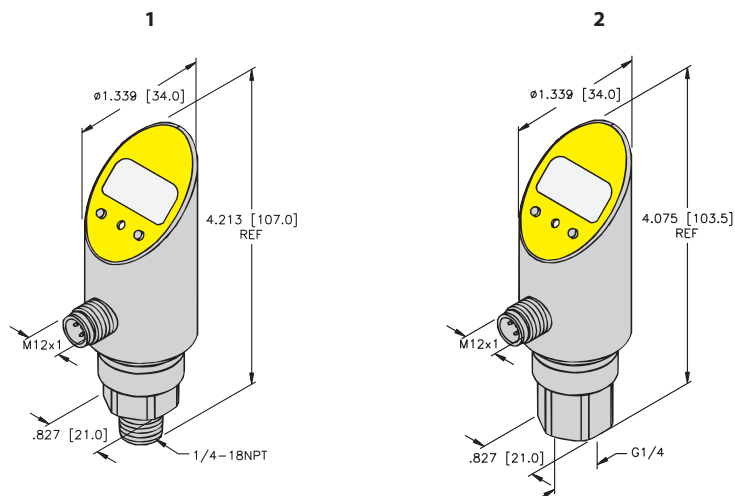

PK Air Pressure Switches

- IP65
- For Air and other Inert Gases
- M8x1 *picofast*[®] Connection
- Vacuum and 10 bar Ranges

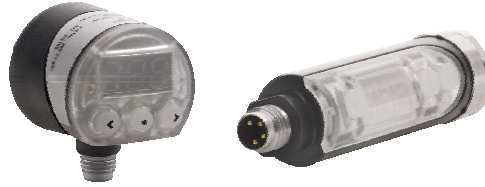

Part Number	Pressure Range	Connection	Output	Drawing
PK010VR-N14AL-2UP8X-V1141	-29.5 to 0 inHg	1/8" NPT	2 PNP N.O./N.C.	1
PK010R-N14AL-2UP8X-V1141	0 to 145 PSI	1/8" NPT	2 PNP N.O./N.C.	1
PK01VR-P14-2UP8X-V1141	-29.5 to 0 inHg	1/8" NPT	2 PNP N.O./N.C.	2
PK010R-P14-2UP8X-V1141	0 to 145 PSI	1/8" NPT	2 PNP N.O./N.C.	2

Specifications	
Electrical	
Response Time	<2.5 ms
Operating Frequency	400 Hz
Supply Voltage	10.8-30 V, keyed residual ripple 10%
Input Current During Programming	<55 mA
Input Current in Normal Operation	<35 mA
Switching Outputs	2x PNP 250 mA short-circuit proof
Display	3 digit 7 segment display
Ambient Temperature Error	3% of measured value at 0 to 50°C
Set Point Accuracy	± 1% full scale
Repeat Accuracy	0.2% of measured value
Hysteresis Adjustable	0 to 100%
Measuring Range	0....-1 bar / 0....10 bar
Burst Pressure	5 bar / 16 bar
Environmental Data	
Protection	IP65
Measuring Medium	Filtered compressed air, lubricated or unlubricated, inert gases
Emitted Interference	DIN EN 50081-1
Interference Immunity	DIN EN 50082-2
High Voltage Test	1000 VDC 1 min
Insulation Resistance	>100 M Ω at 500 VDC
Operating Temperature	-10 to 50°C
Storage Temperature	-20 to 85°C
Permissible Humidity	10 to 90% RH
Shock Resistance	10G XYZ
Vibration Resistance	10 to 55 Hz, 1.5 mm, 3 planes
Mechanical	
Electrical Connector Plug	M8, 4-pin, <i>picofast</i> [®]
Measuring Medium Connector	Male 1/8" NPT

Pressure Instrumentation

Part Number Key

Part Number Keys are to assist in IDENTIFICATION ONLY. Consult factory for catalog items not identified.

PK Sensors - Part Number Key

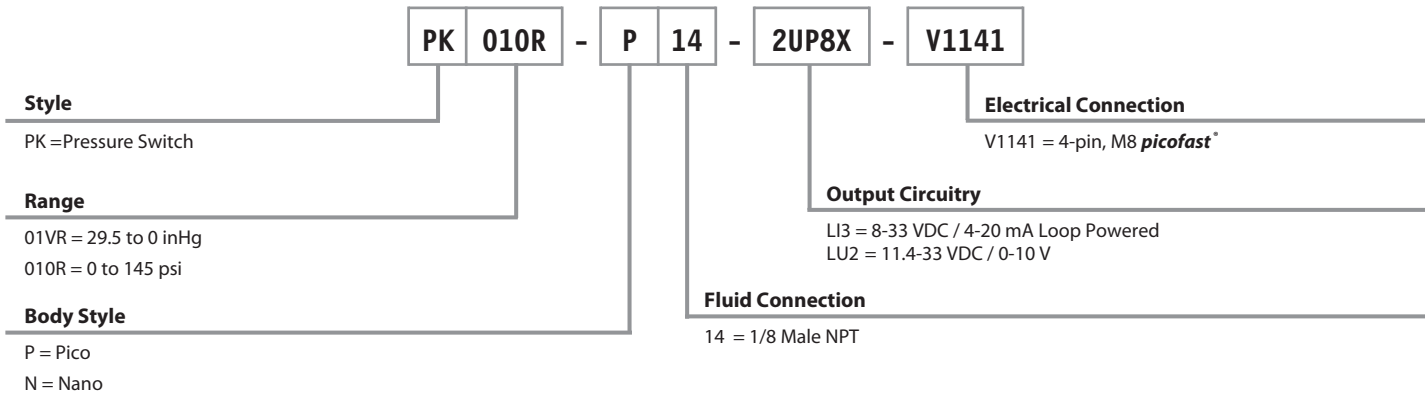

PRESSURE

Drawings

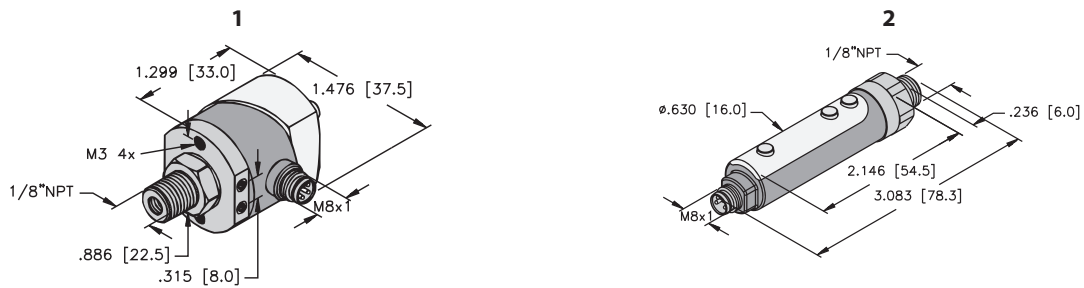

Wiring Diagram

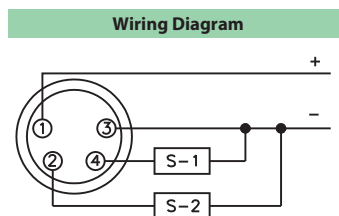

Mating Cordset:
PKG 4M-*

TURCK

Pressure Instrumentation

PT1 Pressure Transmitters Scaled in PSI

- Pre-scaled Ranges - No Adjustment Needed
- Output: 4-20 mA or 0-10 V
- IP67
- Robust Ceramic Measuring Element



Specifications	
Performance	
Accuracy	0.3% of full scale Total of linearity, hysteresis and repeatability
Zero Shift	$\leq 0.015\%$ of measuring range / °C
Span Shift	$\leq 0.015\%$ of measuring range / °C
Overpressure	3 times full scale -14.5 to 30 PSIG 2.5 times full scale 60 to 8700 PSIG up to a maximum of 13,050 PSIG
Environmental Data	
Ambient Temperature	-40 to +85°C (-40 to +185°F)
Medium Temperature	-40°C to +150°C (-40°F to +302°F)
Enclosure Rating	IP67
Housing Material	Stainless Steel 1.430 (AISI 303) / PBT
Shock Resistance	75 G, 11 ms per IEC 68-2-27
Vibration Resistance	20 G, 15 mm per IEC 68-2-6
Wetted Parts	AISI 303 Stainless Steel (connection), Al_2O_3 Ceramic (measuring cell), Viton (seal)
Electrical Data	
Current Consumption	20 mA
Dynamic Response	<math>< 2</math> ms
Short-Circuit Protection	Yes
Reverse Polarity Protection	Yes
Output	4-20 mA Loop Powered 0-10 V
Voltage	8-33 VDC 11.4-33 VDC
Load	4-20 mA: $\frac{\text{supply voltage}-8\text{ V}}{0.02\text{ A}} = \text{Ohm}$ 0-10 V: >10 k / <math>< 100</math> nF

Wiring Diagram

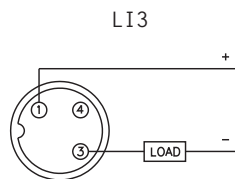

4-20 mA output
2-wire loop power
Mating Cordset:
RK 4T-*/S618

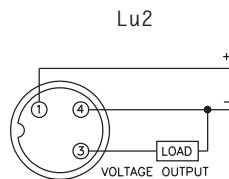

0-10 V output
Mating Cordset:
RK 4T-*/S618

Pressure Instrumentation

Pressure Transmitter Part Number Key

Part Number Keys are to assist in IDENTIFICATION ONLY. Consult factory for catalog items not identified.

Pressure Transmitter (scaled in psi)



Style

PT = Pressure Transmitter

Pressure Range

- 30HG = -30 to 0 in. Hg (vacuum)
- 15psig = 0 to 15 psig
- 30psig = 0 to 30 psig
- 60psig = 0 to 60 psig
- 100psig = 0 to 100 psig
- 150psig = 0 to 150 psig
- 200psig = 0 to 200 psig
- 300psig = 0 to 300 psig
- 500psig = 0 to 500 psig
- 750psig = 0 to 750 psig
- 1000psig = 0 to 1000 psig
- 2000psig = 0 to 2000 psig
- 3000psig = 0 to 3000 psig
- 5000psig = 0 to 5000 psig
- 7500psig = 0 to 7500 psig

Electrical Connection

H1131 = 3-pin, M12 *eurofast*™

Output Circuitry

LI3 = 8-33 VDC / 4-20 mA Loop Powered
 LU2 = 11.4-33 VDC / 0-10 V

Fluid Connection

3 = 1/4 Male NPT

Series

1 = PT1

PRESSURE

Drawing

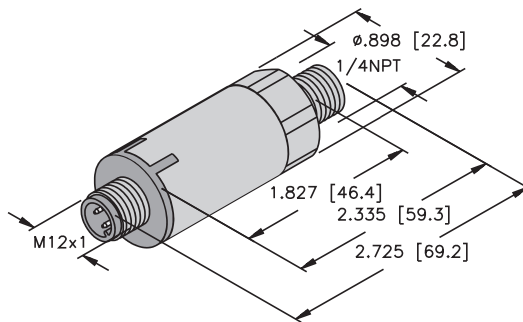

TURCK

Pressure Instrumentation

PT1 Pressure Transmitters Scaled in Bar

- Pre-Scaled in Ranges up to 600 Bar
- Relative or Absolute Versions
- IP67
- Robust Ceramic Measuring Element



Specifications	
Performance	
Accuracy	0.3% of full scale Total of linearity, hysteresis and repeatability
Zero Shift	$\leq 0.015\%$ of measuring range / °C
Span Shift	$\leq 0.015\%$ of measuring range / °C
Overpressure	3 times full scale -1 to 4 bar 2.5 times full scale 6 to 600 bar or up to a maximum of 900 bar
Environmental Data	
Ambient Temperature	-40 to +85°C (-40 to +185°F)
Medium Temperature	-40°C to +150°C (-40°F to +302°F)
Enclosure Rating	IP67
Housing Material	Stainless Steel 1.430 (AISI 303) / PBT
Shock Resistance	75 G, 11 ms per IEC 68-2-27
Vibration Resistance	20 G, 15 mm per IEC 68-2-6
Wetted Parts	AISI 303 Stainless Steel (connection), AL ₂ O ₃ Ceramic (measuring cell), Viton (seal)
Electrical Data	
Current Consumption	20 mA
Dynamic Response	<math>< 2</math> ms
Short-Circuit Protection	Yes
Reverse Polarity Protection	Yes
Output	4-20 mA Loop Powered 0-10 V
Voltage	8-33 VDC 11.4 VDC
Load	4-20 mA: $\frac{\text{supply voltage} - 8 \text{ V}}{0.02 \text{ A}} = \text{Ohm}$ 0-10 V: >10 k / <100 nF

Wiring Diagrams

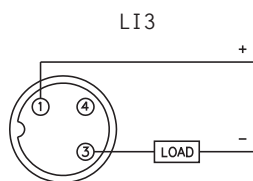

4-20 mA output
2-wire loop power
Mating Cordset:
RK 4T-*/S618

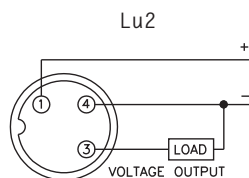

0-10 V output
3-wire voltage output
Mating Cordset:
RK 4T-*/S618

Pressure Instrumentation

Pressure Transmitter Part Number Key

Pressure Transmitter (scaled in bar)

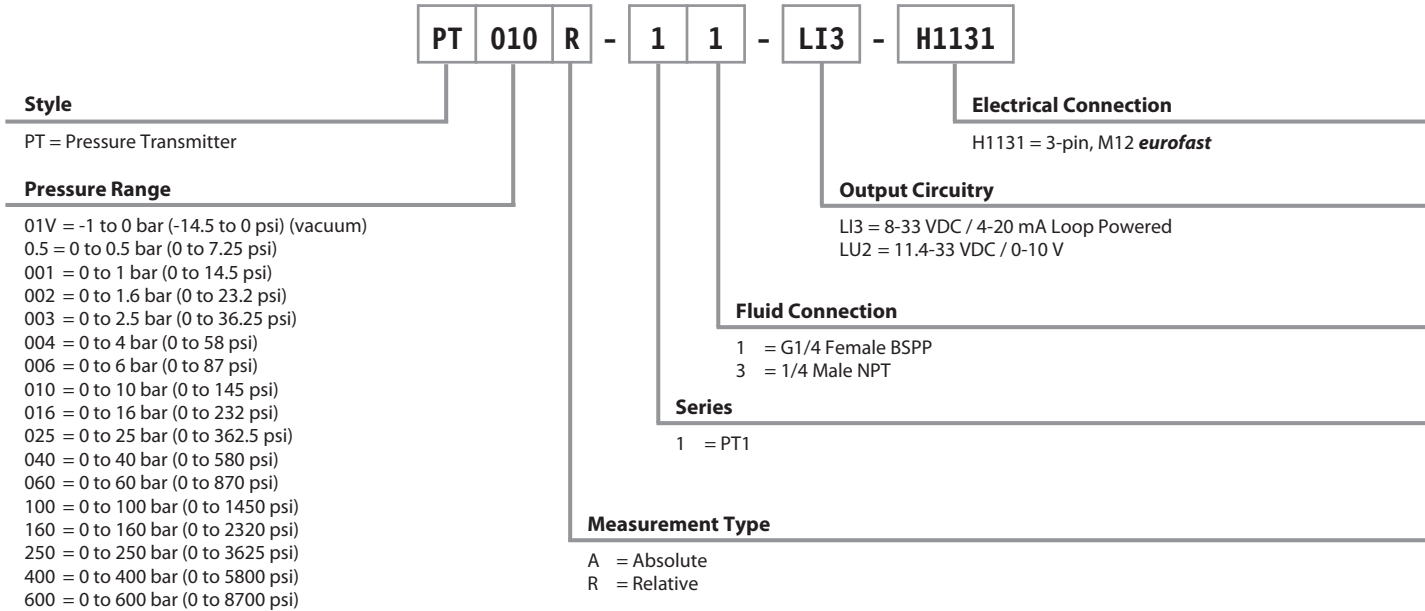

Drawings

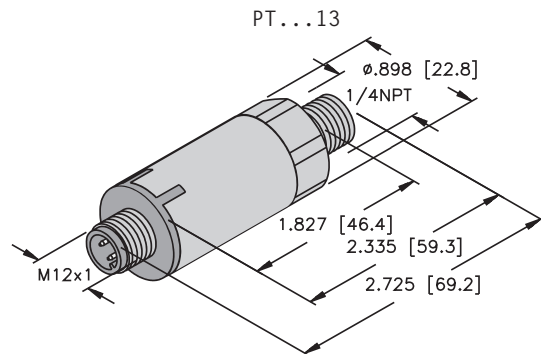
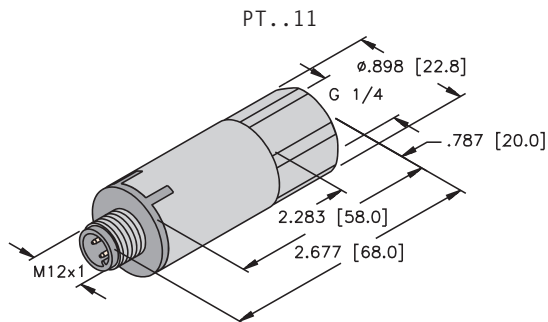

TURCK

Pressure Instrumentation

PT3 Pressure Transmitter

Refrigeration and Pumping Applications

- Fully Welded Stainless Steel Measuring Element
- IP67



Specifications	
Performance	
Accuracy	0.5% of full scale Total of linearity, hysteresis and repeatability
Zero Shift	$\leq 0.015\%$ of measuring range / °C
Span Shift	$\leq 0.015\%$ of measuring range / °C
Overpressure	2.5 times full scale
Environmental Data	
Ambient Temperature	-40 to +85°C (-40 to +185°F)
Medium Temperature	-40°C to +150°C (-40°F to +302°F)
Enclosure Rating	IP67
Housing Material	Stainless Steel 1.430 (AISI 303) / PBT
Shock Resistance	75 G, 11 ms per IEC 68-2-27
Vibration Resistance	20 G, 15 mm per IEC 68-2-6
Wetted Parts	AISI 303 Stainless Steel (connection), AISI 430 Stainless Steel (measuring cell)
Electrical Data	
Current Consumption	20 mA
Dynamic Response	<math>< 2</math> ms
Short-Circuit Protection	Yes
Reverse Polarity Protection	Yes
Output	4-20 mA Loop Powered
Voltage	8-33 VDC
Max. Load	$\frac{\text{supply voltage} - 8V}{0.02 A} = \text{Ohm}$

Wiring Diagram

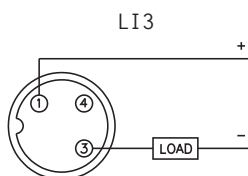

4-20 mA output
 2-wire loop power
 Mating Cordset:
 RK 4T-*/S618

Pressure Instrumentation

Pressure Transmitter Part Number Key

Pressure Transmitter - PT3

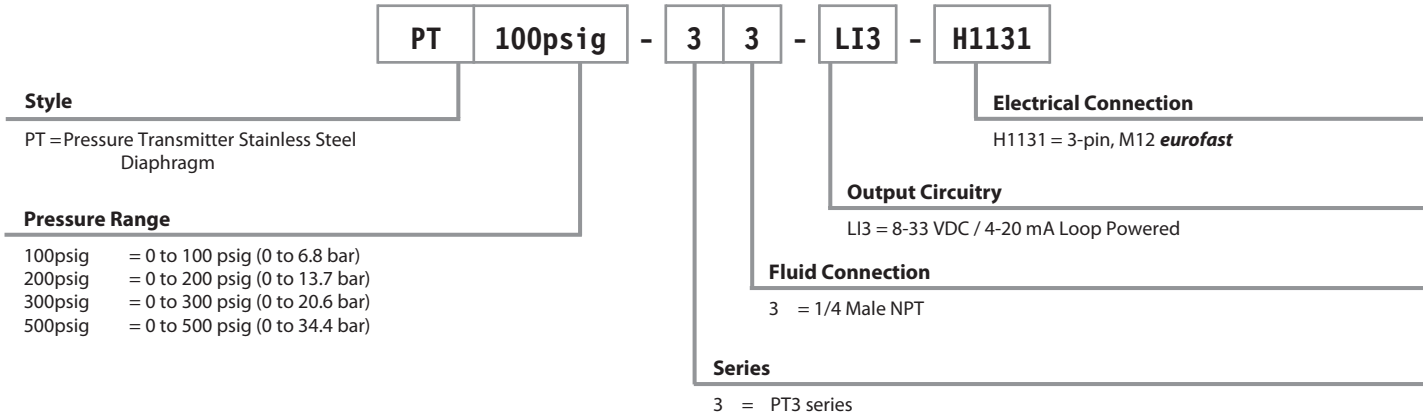

Drawing

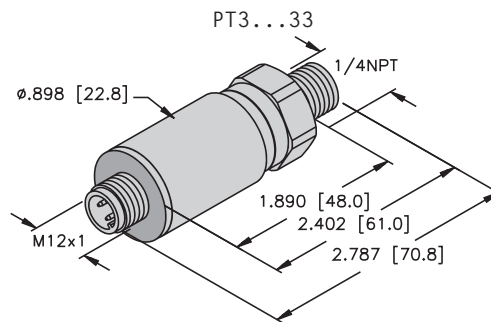

TURCK

Pressure Instrumentation

PT4300 Pressure Sensor, Class 1 Division 2 Groups A, B, C & D

- UL/cUL 1604 (CSA 213) Class 1 Division 2 Groups A, B, C, D
- High Strength Stainless Steel Construction
- Ranges from Vacuum to 10,000 PSI
- Compatible with Wide Range of Liquids and Gases
- EMI/RFI Protection
- No Oil, Welds or Internal O-rings



Specifications	
Applications	
Refrigeration	Water management
Industrial OEM equipment	Oil & gas platforms
Pressure instrumentation	Process control
Gas compression & storage	Test stands
Oxygen delivery systems	Hydrogen fuel (316L)
Performance @25°C (77°F)	
Accuracy*	<±0.25% BFSL
Stability (1 year)	±0.25%FS, typ.
Over pressure protection	2X rated pressure
Burst Pressure	5X or 10,000 psi (whichever is less)
Pressure cycles	> 100 million
* Accuracy includes non-linearity, hysteresis & non-repeatability	
Environmental Data	
Operating temperature	-40 to +85°C (-40 to +185°F)
Storage temperature	-40 to +100°C (-13 to +212°F)
Compensated range	0 to +55°C (-30 to +130°F)
TC zero	<±1.5% of FS
TC span	<±1.5% of FS
Vibration test	10G peak, 20 to 2000 Hz
Shock test	100G, 11 msec, 1/2 sine
EMI/RFI protection	Yes
Rating	IP66

Wiring		
Output Type	VAS	C0244
LI3	Pin 1: V+ Pin 2: V- Pin 3: N/C Pin 4: N/C	RED: V+ BLK: V- WHT: N/C GRN: N/C
LU4/LU64/LU65	Pin 1: V+ Pin 2: V- Pin 3: S Pin 4: N/C	RED: V+ BLK: V- WHT: S GRN: N/C
LU71	Pin 1: S+ Pin 2: V- Pin 3: V+ Pin 4: S-	RED: V+ BLK: V- WHT: S- GRN: S+

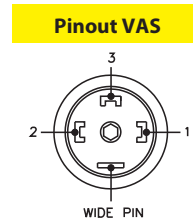

Electrical Data				
Output	4-20 mA	1-5 VDC, 1-6 VDC	0-50 mV	0.5-4.5 V Ratiometric
Excitation	10-28 VDC	10-28 VDC	5 VDC, typ	5 VDC, typ
Output impedance	>10k	<100 , nominal	<1100 , nominal	<100 , nominal
Current consumption	20 mA, typ	<10 mA	<5 mA	<10 mA
Bandwidth	(-3dB): DC to 250 Hz	(-3dB): DC to 1 kHz	(-3dB): DC to 5 kHz, min	(-3dB): DC to 1 kHz
Output noise	-	<2 mV RMS	-	<2 mV RMS
Zero offset	<±1% of FS	<±1% of FS	<±2% of FS	<±1% of FS
Span tolerance	<2% FS	<±1.5% FS	<±2% FS	<1.5% FS
Output load	0-800 @ 10-28 VDC	10 k min.	1 M	10 k min
Reverse polarity Protection	Yes	Yes	-	No

Pressure Instrumentation

Class 1 Division 2 Pressure Transmitters Part Number Key

Part Number Keys are to assist in IDENTIFICATION ONLY. Consult factory for catalog items not identified.

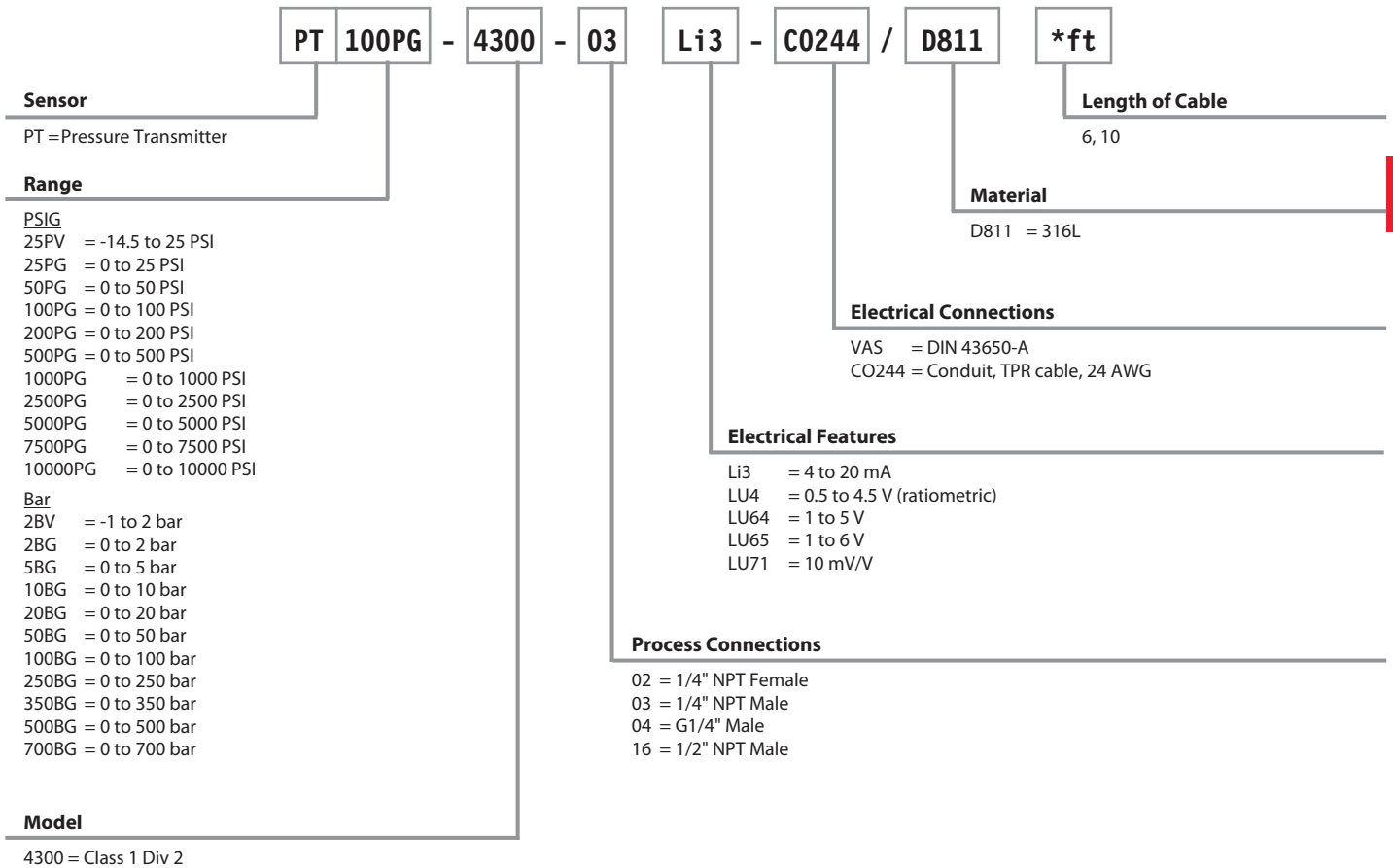

PRESSURE

Drawings

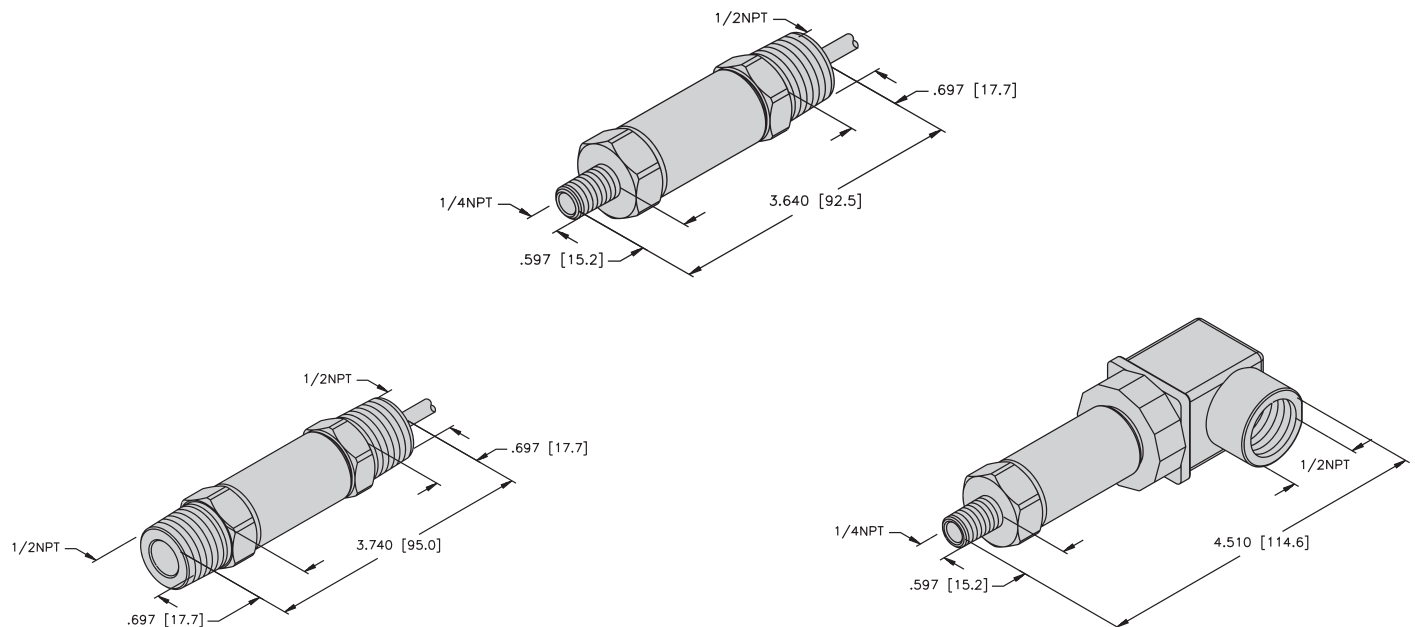

TURCK

Pressure Instrumentation

PT4400 Pressure Sensor, Class 1 Division 1 Groups C & D

- UL/cUL 913 (CSA 157) Class 1 Division 1 Groups C & D when installed with an approved barrier
- High Strength Stainless Steel Construction
- Ranges up to 10,000 PSI
- Compatible with Wide Range of Liquids and Gases
- EMI/RFI Protection
- No Oil, Welds or Internal O-rings

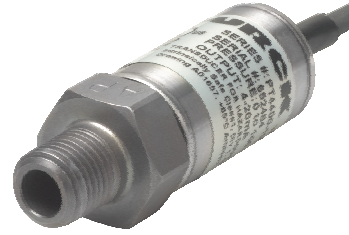

Specifications	
Applications	
Pneumatics	Water management
Industrial OEM equipment	Hydraulic systems
Control panels	Data loggers
HVAC® equipment	Hydrogen fuel (316L)
Performance @25°C (77°F)	
Accuracy*	<±0.25% BFSL
Stability (1 year)	±0.25%FS, typ.
Over pressure protection	2X rated pressure
Burst Pressure	5X or 10,000 psi (whichever is less)
Pressure cycles	> 100 million
* Accuracy includes non-linearity, hysteresis & non-repeatability	
Environmental Data	
Operating temperature	-40 to +85°C (-40 to +185°F)
Storage temperature	-40 to +100°C (-13 to +212°F)
Compensated range	0 to +55°C (-30 to +130°F)
TC zero	<±1.5% of FS
TC span	<±1.5% of FS
Vibration test	10G peak, 20 to 2000 Hz
Shock test	100G, 11 msec, 1/2 sine
EMI/RFI protection	Yes
Rating	IP66

Wiring		
Output Type	H1141	CA244
LI3	Pin 1: V+ Pin 2: N/C Pin 3: V- Pin 4: N/C	RED: V+ BLK: V- WHT: N/C GRN: N/C
LU4/LU64/LU65	Pin 1: V+ Pin 2: N/C Pin 3: V- Pin 4: S	RED: V+ BLK: V- WHT: S GRN: N/C
LU71	Pin 1: V+ Pin 2: S+ Pin 3: S- Pin 4: V-	RED: V+ BLK: V- WHT: S- GRN: S+

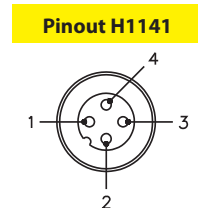

Electrical Data				
Output	4-20 mA	1-5 VDC, 1-6 VDC	0-50 mV	0.5-4.5 V Ratiometric
Excitation	10-28 VDC	10-28 VDC	5 VDC, typ	5 VDC, typ
Output impedance	>10k	<100 Ω, nominal	<1100 Ω, nominal	<100 Ω, nominal
Current consumption	20 mA, typ	<10 mA	<5 mA	<10 mA
Bandwidth	(-3dB): DC to 250 Hz	(-3dB): DC to 1 kHz	(-3dB): DC to 5 kHz, min	(-3dB): DC to 1 kHz
Output noise	-	<2 mV RMS	-	<2 mV RMS
Zero offset	<±1% of FS	<±1% of FS	<±2% of FS	<±1% of FS
Span tolerance	<±2% of FS	<±1.5% of FS	<±2% of FS	<±1.5% of FS
Output load	0-800 Ω @10-28 VDC	10k Ω, min	>1M	10k Ω, min
Reverse polarity protection	Yes	Yes	-	No

Pressure Instrumentation

Class 1 Division 1 Pressure Transmitters Part Number Key

Part Number Keys are to assist in IDENTIFICATION ONLY. Consult factory for catalog items not identified.

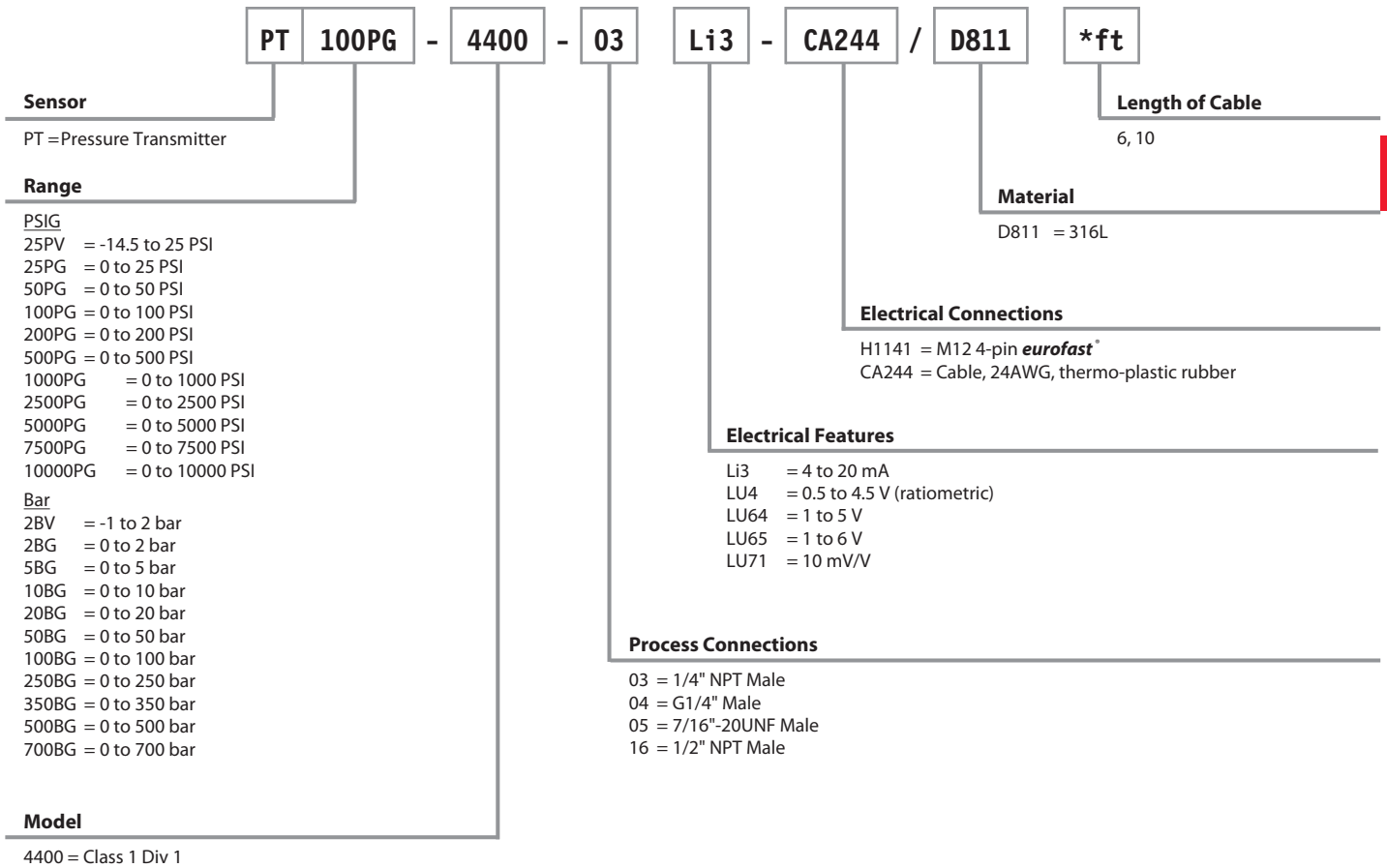

PRESSURE

Drawings

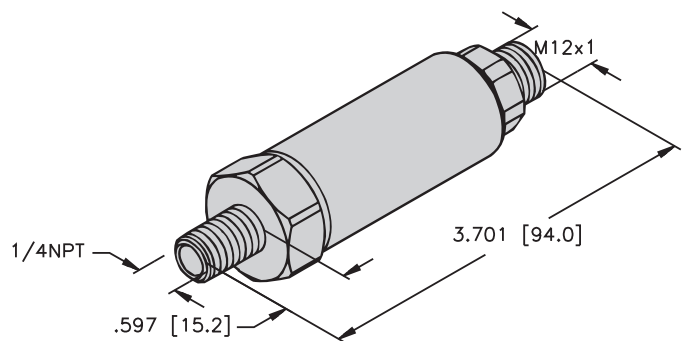
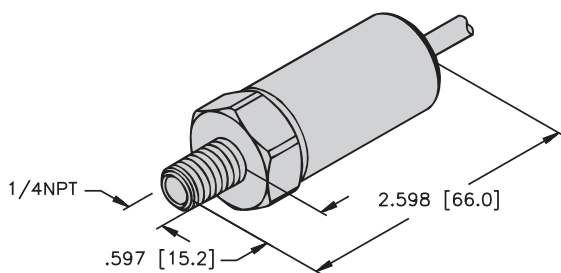

TURCK

Pressure Instrumentation

PT4500 & PT4510 Submersible Pressure Transmitters

- UL/cUL 913 (CSA 157) Class 1 Division 1 Groups C, D when installed with an approved barrier per control drawing IS1.904
- High Strength Stainless Steel Construction
- Ranges from 0-2.5 PSIG up to 0-100 PSIG
- Compatible with Wide Range of Liquids



Specifications	
Applications	
Liquid tanks	Wastewater canals
Gasoline and diesel tanks	Irrigation
Performance @25°C (77°F)	
Accuracy*	<±0.25% BFSL
Zero offset	<±1% of FS
Span tolerance	<±2% of FS
Stability (1 year)	±0.25%FS, typ
Over pressure protection	2X rated pressure
Burst Pressure	5X or 1,250 psi (whichever is less)
Pressure cycles	> 50 million
* Accuracy includes non-linearity, hysteresis & non-repeatability	
Environmental Data	
Operating temperature	-40 to +85°C (-40 to +185°F)
Storage temperature	-40 to +100°C (-40 to +212°F)
Compensated range	0 to +55°C (30 to +130°F)
TC zero	<±1.5% of FS
TC span	<±1.5% of FS
Vibration test	10G peak, 20 to 2000 Hz
Shock test	100G, 11 msec, 1/2 sine
EMI/RFI protection	Yes
Rating	IP68
Electrical Data	
Output	4-20mA
Excitation	10-28 VDC
Output impedance	>10k
Current consumption	20 mA, typ
Bandwidth	(-3dB): DC to 250 Hz
Output noise	-
Output load	0-800 @10-28 VDC
Reverse polarity protection	Yes

Wiring	
Output Type	CAH
LI3	RED: V+ BLK: V- WHT: N/C GRN: N/C VENT: N/C

Pressure Instrumentation

PT4500 & PT4510 Submersible Transmitters Part Number Key

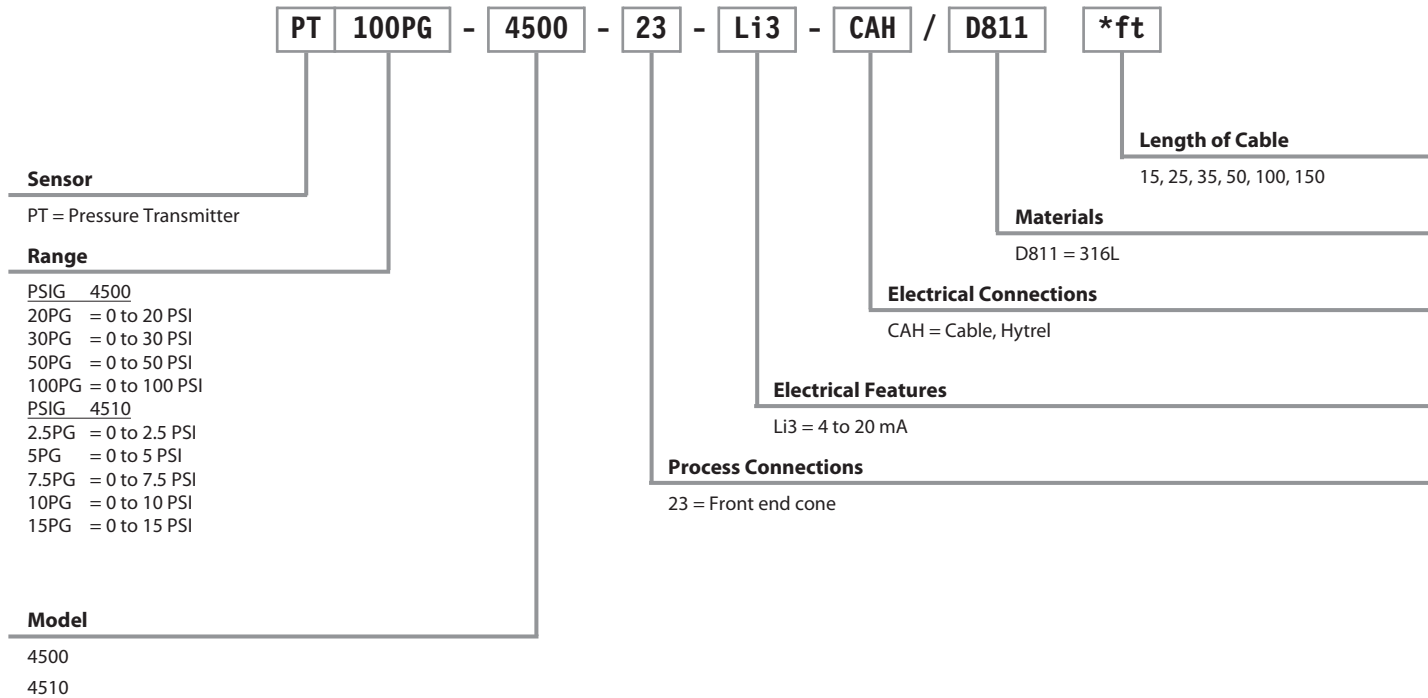

Drawings

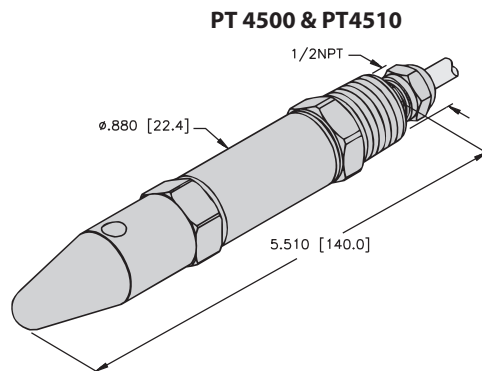

TURCK

Pressure Instrumentation

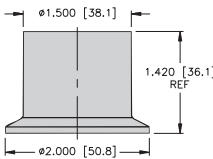
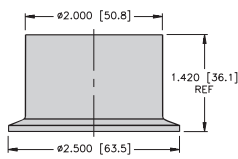
Housing Style	Part Number	Process Connection	Lower Housing	Diaphragm	Upper Housing	Fill Fluid	Maximum Working Pressure at 100°F	Standards
Sanitary Diaphragm 	PT.../S1604 PS.../S1604	1.5 in. Tri-clamp	316 L	316 L	316 L	Neobe M20	600 psi	3A 37-01
Sanitary Diaphragm 	PT.../S1605 PS.../S1605	2.0 in. Tri-clamp	316 L	316 L	316 L	Neobe M20	600 psi	3A 37-01

Diaphragm seals must be ordered factory assembled with **TURCK** pressure sensors or pressure transmitters.
 For optional fill fluids and materials see page B36 at the end of this section.

Due to the continuous improvement, dimensions/specifications are subject to change without notice.

Pressure Instrumentation

Housing Style	Part Number	Process Connection	Lower Housing	Diaphragm	Upper Housing	Fill Fluid	Maximum Working Pressure at 100°F
Fully Welded Diaphragm Seal 	PT.../S1685 PS.../S1685	1/4 NPT Female	316 L	316 L	316 L	Silicone DC200	2500 psi
Fully Welded Diaphragm Seal, Clean Out Port 	PT.../S1593 PS.../S1593	1/4 NPT Female	316 L	316 L	316 L	Silicone DC200	2500 psi
General Purpose, Welded Diaphragm 	PT.../S1049 PS.../S1049	1/2 NPT Female	316 L	316 L	316 L	Silicone DC200	2500 psi

PRESSURE

Diaphragm seals must be ordered factory assembled with **TURCK** pressure sensors or pressure transmitters. For optional fill fluids and materials see page B36 at the end of this section.

Due to continuous improvement, dimensions/specifications are subject to change without notice.

TURCK

Pressure Instrumentation

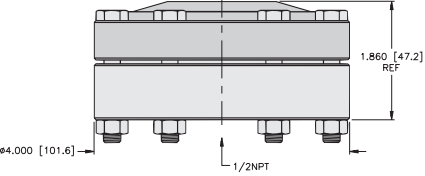
Housing Style	Part Number	Process Connection	Lower Housing	Diaphragm	Upper Housing	Fill Fluid	Maximum Working Pressure at 100°F
Chemical Resistant, Welded Diaphragm 	PT.../S1731 PS.../S1731	1/2 NPT Female	PVC	Hastelloy C276	316 L	Silicone DC200	200 psi

Diaphragm seals must be ordered factory assembled with **TURCK** pressure sensors or pressure transmitters. For optional fill fluids and materials see page B36 at the end of this section.

Due to continuous improvement, dimensions/specifications are subject to change without notice.

Pressure Instrumentation

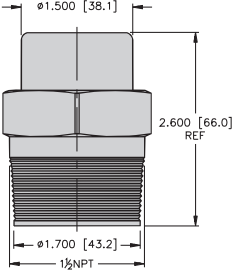
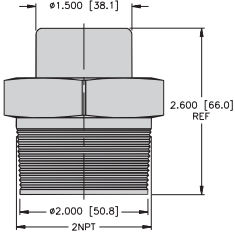
Housing Style	Part Number	Process Connection	Lower Housing	Diaphragm	Upper Housing	Fill Fluid	Maximum Working Pressure at 100°F
<p>Flush Mount Diaphragm</p> 	<p>PT.../S1704 PS.../S1704</p>	1-1/2 NPT Male	316 L	316 L	316 L	Silicone DC200	3500 psi
<p>Flush Mount Diaphragm</p> 	<p>PT.../S1705 PS.../S1705</p>	2 NPT Male	316 L	316 L	316 L	Silicone DC200	2500 psi

PRESSURE

Diaphragm seals must be ordered factory assembled with **TURCK** pressure sensors or pressure transmitters. For optional fill fluids and materials see page B36 at the end of this section.

Due to continuous improvement, dimensions/specifications are subject to change without notice.

TURCK

Pressure Instrumentation

Accessories

Adapter, G1/4 to 1/2NPT
(316 Stainless Steel)
.748 [19.0] across flats

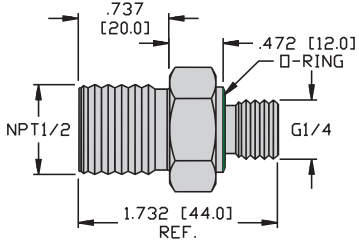

PCV-N1/2A4
 (M6835013)

Adapter, G1/4 to G1/4
(316 Stainless Steel)
.748 [19.0] across flats

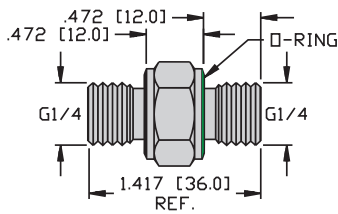

PCV-G1/4A4
 (M6835011)

Adapter, G1/4 to 1/4 NPT
(316 Stainless Steel)
.748 [19.0] across flats

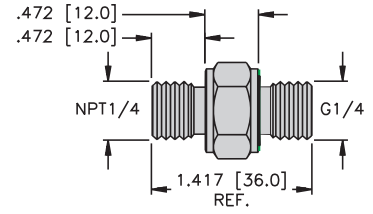

PCV-N1/4A4
 (M6835022)

Adapter, G1/4 to 1/8NPT
(316 Stainless Steel)
.748 [19.0] across flats

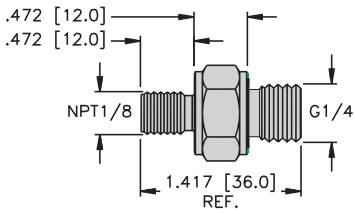

PCV-N1/8A4
 (M6835021)

Adapter, G1/4 to 7/16 SAE
(316 Stainless Steel)
.748 [19.0] across flats

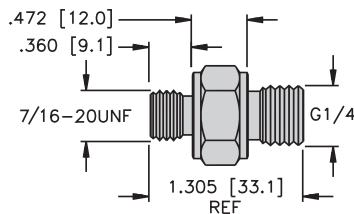

PCV-S7/16A4
 (A9136)

Cover for PS Series

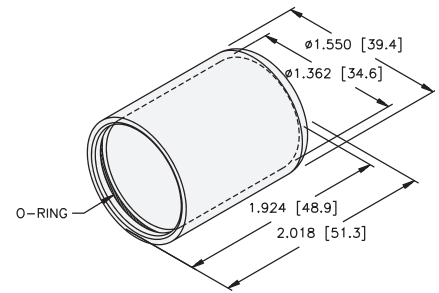

PTS Cover
 (A9350)

Diaphragm Seal Optional Materials

Optional Fill Fluids

Diaphragm Fill Fluids	Application Range (°C)	Specific Gravity at 25°C	Viscosity at 25°C
Silicone DC200-10CS	-45 to 205	0.93	10
Silicone DC 704	0 to 315	1.07	39
Silicone DC 710	5 to 345	1.11	500
Flourolube FS-5	-40 to 150	1.88	7.8
Halocarbon Oil 6.3	-40 to 235	1.88	10.6
Halocarbon Oil 4.2	-45 to 175	1.85	6.5
Neobee-20	-15 to 205	0.92	9.8

PRESSURE

Optional Materials

Housing Material			
Wetted			Non-Wetted
304 SS (304)	Hastelloy B-2 (HASB)	PVC	304 SS (304)
304L SS (304L)	Hastelloy C-276 (HASC)	Tantalum (TANT)	316 SS (316)
316 SS (316)	Inconel 600 (INC)	PTFE-25%GF (TFGF) (+1500°F max.)	Monel 400 (MON)
316Ti SS	Inconel 625 (I625)	Titanium GR.4 (TIT)	
Carpenter 20 (C20)	Monel 400 (MON)	Zirconium 702 (ZIRC)	
Hast-C22 (HAS2)	Nickel 200 (NICK)		

Diaphragm Material			
Wetted			
304L SS (304L)	Hastelloy B-2 (HASB)	Silver (SILV)	
316L SS (316L)	Hastelloy C-276 (HASC)	Tantalum (TANT)	
321 SS (321)	Inconel 600 (INC)	PTFE Coated Metal	
Buna N (NBR) (1250 psi; +2500°F)	Kalrez 1050LF (KALR)	PTFE (TFE) (1250 psi; +3500°F)	
Carpenter 20 (C20)	Kel-F (KELF) (1250 psi; +4000°F)	Titanium GR4 (TIT)	
(for anti-stick purposes only)	Monel 400 (MON)	Viton A (VIT) (1250 psi; +3500°F)	
Gold (GOLD)	Nickel 200 (NICK)	Zirconium 702 (ZIRC)	
Hast - C22 (HAS2)	Nickel 201 (N201)		

Gasket Material			
Wetted			
	Grafoil (GRAF)	PTFE (3510) (-400°F to +2000°F)	
	Non-Asbestos (4401)	PTFE (K2) (-500°F to +4500°F)	

O-Ring Material			
Wetted			
	Buna N (NBR) (-100°F to +2500°F)	PTFE (TFE) (-400°F to +3500°F)	
	Kalrez (KALR)	Viton A (VIT) (-100°F to +3500°F)	

TURCK

Pressure Instrumentation

Pressure Conversion⁽¹⁾

From / To	PSI	KPA	inH ₂ O ⁽²⁾	mmH ₂ O	inHg ⁽³⁾	mmHg	Bar	mBars	Kg/cm ²	gm/cm ²
PSI	1	6.8948	27.7620	705.1500	2.0360	51.7149	0.0689	68.9470	0.0703	70.3070
KPA	0.1450	1	4.0266	102.2742	0.2953	7.5006	0.0100	10.0000	0.0102	10.197
inH₂O	0.0361	0.2483	1	25.4210	0.0734	1.8650	0.0025	2.4864	0.0025	2.5355
mmH₂O	0.0014	0.0098	0.0394	1	0.0028	0.0734	0.0001	0.0979	0.00001	0.0982
inHg	0.4912	3.3867	13.6195	345.936	1	25.4000	0.0339	33.8639	0.0345	34.532
mmHg	0.0193	0.1331	0.5362	13.6195	0.0394	1	0.0013	1.3332	0.0014	1.3595
Bar	14.5040	100.000	402.180	10215.0	29.5300	750.060	1	1000	1.0197	1019.72
mBars	0.0145	0.1000	0.4022	10.2150	0.0295	0.7501	0.001	1	0.0010	1.0197
Kg/cm²	14.2233	97.9047	394.408	10018.0	28.9590	735.559	0.9000	980.700	1	1000
gm/cm²	0.0142	0.0979	0.3944	10.0180	0.0290	0.7356	0.0009	0.9807	0.001	1

(1) Example:

1 mm Hg = 0.5362 inH₂O = 1.3332 mBars

97 mm Hg = 97(0.5362) = 52.0114 inH₂O

97 mm Hg = 97(1.332) = 129.3204 mBars

(2) at 60°F

(3) at 32°F





Pressure Instrumentation



Notes:

PRESSURE

FLOW MONITORS SELECTION GUIDE

Housing	Style	Technology	Advantage	Page
	FCMI Magnetic Inductive	Magnetic Inductive	<ul style="list-style-type: none"> ■ Meter for electrically conductive fluids ■ ±2% of reading accuracy ■ 0-9.9 GPM or 0-20 GPM models 	C3
	FTCI Digital Read Out	Calorimetric	<ul style="list-style-type: none"> ■ Displays flow and temperature ■ Linearized, output for water, water/glycol mixtures, Galden® HT, ZT ■ Set points for flow & temperature ■ Outputs: 2 analogs, 4 setpoints, 2 setpoints, 1 analog, 1 setpoint 	C7
	FCI Inline	Calorimetric	<ul style="list-style-type: none"> ■ Intrinsically safe models (ATEX approved) ■ Faster response time than probes ■ Remote mounting options ■ Low flow rates detection down to 1 ml/min 	C11
	FCS Probe	Calorimetric	<ul style="list-style-type: none"> ■ Probe lengths vary for larger pipes ■ Remote mounting options (requires remote amplifier) ■ Intrinsically safe models (ATEX approval) ■ Chemically resistant models available 	C21
	FCS.../A Airflow	Calorimetric	<ul style="list-style-type: none"> ■ Can monitor air and other inert gases ■ Probes and inlines available 	C41
Remote Amplifiers			<ul style="list-style-type: none"> ■ Signal processors for remote probes 	C49
Flow Conversion Chart			<ul style="list-style-type: none"> ■ Allows flow rate conversions from linear flow to volumetric flow and vice versa for liquids and gases 	C51

FLOW MONITORS

PRODUCT OVERVIEW

WHAT ARE TURCK FLOW MONITORS?

TURCK flow monitors are solid-state devices that operate on the calorimetric or magnetic inductive principle. The monitors do not include any moving parts that may break or become lodged in the pipeline, as is often the case with mechanical devices that come in contact with the media being sensed.

WHY CHOOSE TURCK FLOW MONITORS?

- Choice of monitor to suit specific application needs: Inline models, self-contained devices or remote probe styles (with a separate signal processor).
- Rugged design; most monitors are rated for IP67 protection.
- All wetted parts are made of stainless steel, titanium, Hastelloy or PVDF.
- Select models designed to withstand caustic materials.
- Pressure ratings of up to 1450 psi on select models.
- Calometric flow monitors have a temperature gradient of 4°C/sec, which allows them to respond rapidly to changes in flow.

WHERE CAN I USE TURCK FLOW MONITORS?

Any application that requires monitoring water, oil, inert gases and air flow. In applications with a larger pipe or long standoff, probes are available in 20 millimeter increments with a maximum length of 220 millimeters.

- Pump run dry protection
- Dosing monitoring/verification
- Industrial ventilation
- Filtration systems
- Lubrication monitoring
- Cooling systems
 - » Welders
 - » Power transformers
 - » Laser systems
 - » Molding
 - » Casting



FTCI: flow and temperature with digital display



Inline flow sensor



Probe style flow sensor

FCMI MAGNETIC INDUCTIVE FLOW MONITOR

PRODUCT OVERVIEW

WHAT IS THE FCMI FLOW MONITOR?

The FCMI magnetic inductive flow monitor was designed for measuring electrically conductive liquids using Faraday's inductive measuring principle. Electrons in the fluid are driven to the pipe wall when passing through the magnetic field created in the measuring pipe. This causes a potential difference that is detected by two laterally mounted electrodes. Based on the known magnetic field and the electrode spacing, the measured potential difference at the electrodes is proportional to the flow speed and therefore the flow rate.

WHY CHOOSE THE FCMI FLOW MONITOR?

- The FCMI is completely wear-free, because it has no moving parts. In contrast to monitors that employ other measuring principles, FCMI monitors do not require a reduction of the pipe diameter and do not obstruct the flow of the medium.
- Easy-to-use push buttons for programming the monitor are password protected to prevent inadvertently altering flow settings.
- Measuring accuracy: 2% of the measured value
- Available with 1 switching output and linear 4-20 mA analog output

WHERE CAN I USE FCMI FLOW MONITORS?

- Ideal for applications with low to medium flow rates up to 20 gpm in a 3/4" pipe.
- Electrically conductive fluids, i.e. water/water based fluids:
 - » Minimum conductivity: 10 $\mu\text{S}/\text{cm}$
For example: water = 15 $\mu\text{S}/\text{cm}$

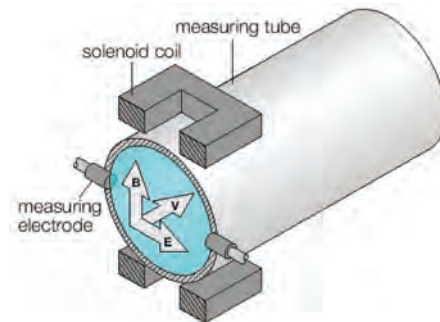

FCMI monitors utilize Faraday's magnetic inductive principle

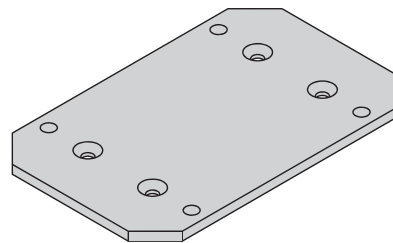

FCMI monitors may be secured using the four M4 threaded holes located on the bottom of the housing. An optional mounting plate (pictured above) may be used for applications that use flexible tubing. Compression fittings and NPT adapters are also available.

Digital Read Out Flow Sensor - Magnetic Inductive Part Number Key

FCMI - 3/8 D08 DYA4P - LI-UP8X - H1141

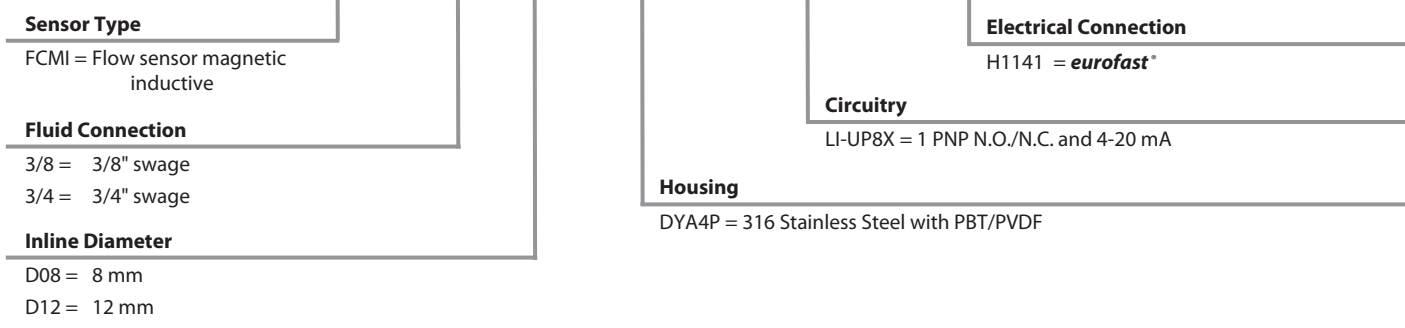

FLOW

TURCK

Flow Monitors

FCMI Flow Monitors

- Magnetic Inductive flow meters
- IP65
- Flow rates up to 20 GPM
- Great for water metering applications



Part Number	Flow Rate (GPM)	Measuring Tolerance	Fluid Connection (swage)	In-line Diameter (mm)	Media Temperature (°C)	Output 1: Flow	Output 2: Flow	Conductive Fluids > 10 micro-Siemens/cm	Adapter Color Code
FCMI-3/8D08DYA4P-LI-UP8X-H1141	0-9.9	<1.33 gpm = +/- .027 gpm >1.33 gpm = +/- 2% measured value	3/8"	8	5 to 60	4-20 mA Analog	PNP NO/NC		
FCMI-3/4D12DYA4P-LI-UP8X-H1141	0-20	<2.0 gpm = +/- .1 gpm >2.0gpm = +/- 2% measured value	3/4"	12	5 to 60	4-20 mA Analog	PNP NO/NC		

Specifications:	
Electrical	
Operating Voltage	21.6-26.4 VDC
Current Consumption	<100 mA
Switching Current PNP outputs	200 mA
Analog Load	200-500
Environmental	
Protection	IP65
Pressure Rating	145 PSI
Ambient Temperature	0 to 60 °C
Materials	
Housing	PBT
Wetted Parts:	
Tubing	316 TI Stainless Steel
O-ring	PVDF
Operational	
Response time	.5 seconds
Switch On/Off Delay	0-50 seconds
Time Delay before Availability	6-10 seconds

Parameter Ranges for Available Models

Size	Detection Range Flow	Adjustment Range SP1	Hysteresis Flow Switch Points	Analog Start Point Range	Analog End Point Range
3/8"	0.0 to 9.99 gpm 0.0 to 37.8 l/min	0.5 to 9.95 gpm 1.8 to 37.8 l/min	0.05 to 1.5 gpm 0.2 to 5.6 l/min	0.0 to 2.5 gpm 0.0 to 9.4 l/min	2.5 to 9.99 gpm 9.4 to 37.8 l/min
3/4"	0.0 to 20 gpm 0.0 to 75.7 l/min	1.0 to 20 gpm 3.7 to 75.7 l/min	0.1 to 2 gpm 0.4 to 7.5 gpm	0.0 to 15 gpm 0.0 to 56.8 l/min	5.0 to 20 gpm 18.9 to 75.7 l/min

Flow Monitors

Drawings

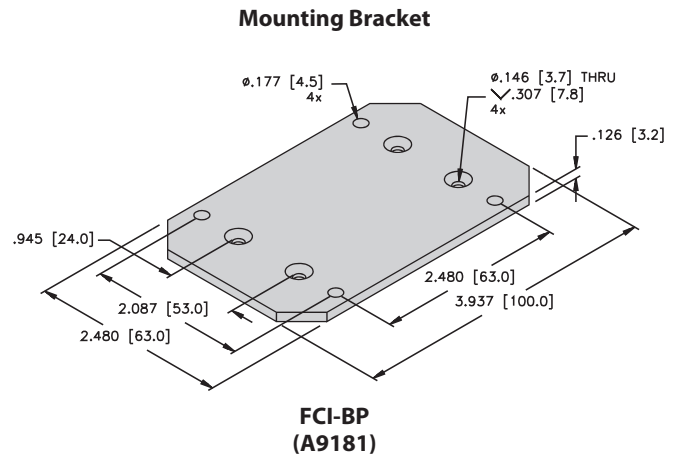
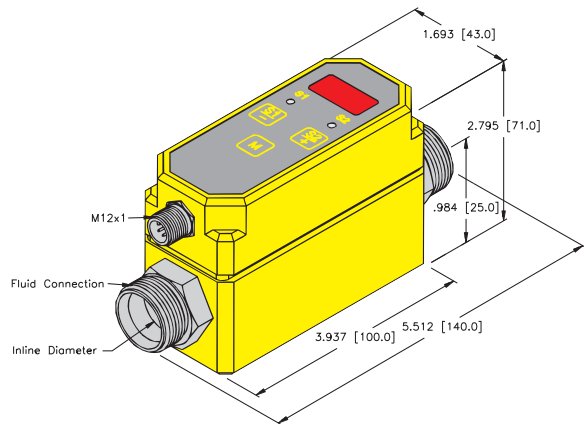

FLOW

Wiring Diagram

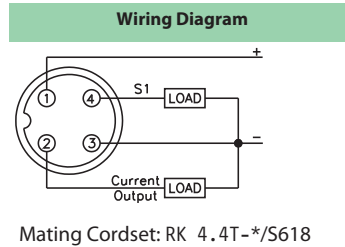

Adapter Options

FSV-SS 3/4 KIT (2 sets) (A9185)

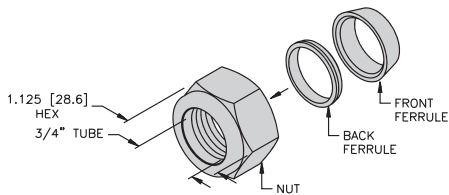

FSV-SS 3/8 KIT (2 sets) (A9183)

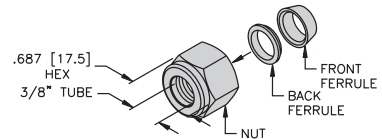

FSV-SS 3/4 TS-NPT (A9306)

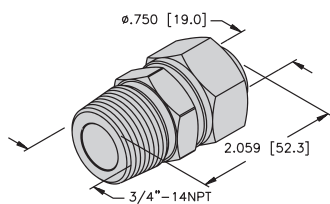

FSV-SS 3/8 TS-NPT (A9307)

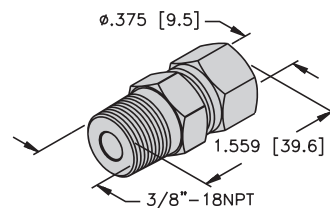

FTCI DIGITAL READ OUT FLOW MONITOR

PRODUCT OVERVIEW

WHAT IS THE FTCI FLOW MONITOR?

The FTCI inline flow monitor is a self-contained, solid-state, fully programmable sensor that monitors both flow and temperature. The monitor operates using the calorimetric flow principle, which detects the transfer of heat in thermally conductive fluids. The temperature detecting elements are platinum RTDs. One of the elements (R1) detects the temperature of the fluid in the pipe and the resistor (R2) is connected to a heater. The heating element heats R2 to a temperature that is slightly above the temperature of the surrounding fluid. When there is no fluid flow, the difference between R1 and R2 remains constant. As the fluid moves through the sensor, heat is conducted away from the heated element causing the temperature of R2 to decrease. This heat loss causes the differential resistance input to the amplifier where the various outputs are generated.

WHY CHOOSE THE FTCI FLOW MONITOR?

- Rugged design implements stainless steel wetted parts and mounts directly into the pipeline.
- Highly visible three-digit display that can alternate between flow rate and media temperature.
- High repeatability; able to monitor changes in flow as low as 0.2 gallons per minute (gpm) or as fast as 12 gpm.
- Easy-to-use push buttons for programming the monitor are password protected to prevent inadvertently altering flow settings.
 - » Two outputs to monitor flow rate, or one output for flow rate and one output for temperature.
 - » Programmable on and off time delay functions.
 - » User defined hysteresis for both the flow and temperature set points.
- Programmed to perform in many different media.
 - » Water
 - » Deionized water
 - » Ethylene glycol (0-70%)
 - » If the fluid is a glycol/water mix, the percentage of glycol can be programmed so that the monitor can adjust to each unique application without the need for factory calibration.
- Can be programmed for liters per minute or gallons per minute, as well as °F or °C.
- An adjustable filter to smooth out a variety of erratic flow conditions.
- Pressure resistance of 145 psi.

WHERE CAN I USE THE FTCI FLOW MONITORS?

- Weld tip protection
- Transformer cooling
- Process chamber cooling
- Hot roller coolant
- Cooling water monitor



FTCI monitors are available with different fluid connections and accessories. It is manufactured with a standard *euromast*® M12 connector.

Flow Monitors

Digital Read Out Flow Monitor Part Number Key



<p>Sensor Type</p> <p>FTCI = Inline Flow and Temperature Sensor</p>	<p>Fluid Connection</p> <p>3/8 = 3/8" swage 1/2 = 1/2" swage 3/4 = 3/4" swage</p>	<p>Inline Diameter</p> <p>D10 = 10 mm D15 = 15 mm</p>	<p>Electrical Connection</p> <p>H1141 = <i>eurofast</i>[®] H1160 = <i>eurofast</i></p>	<p>Circuitry</p> <p>2UP8X = Dual PNP N.O./N.C. 4UP8X = 4 PNP N.O./N.C. LI-UP8X = 1 PNP N.O./N.C. and 4-20 mA 2LIX = Dual 4-20 mA 2ARX = Dual N.O. Relay</p>	<p>Housing</p> <p>A4P = 316 Stainless Steel with PBT Housing</p>
--	--	--	--	--	---

FLOW

TURCK

Flow Monitors

FTCI Flow and Temperature Monitors

- Flow and Temperature Outputs
- IP65
- Flow rates up to 12 GPM
- Great for Cooling Water, Weld Tip Protection, Process Chamber Cooling, & Hot Roller Applications



Part Number	Flow Monitoring Range (GPM)	Fluid Connection (swage)	In-line Diameter mm	Temperature Monitoring Range (°C)	Output 1: Flow or Temperature	Output 2: Flow	Output 3: Temperature	Output 4: Temperature	Water	Deionized Water	Water/Glycol Mixes <70%	Golden ZT	Golden HT135	Wiring Diagram #	Adapter Color Code
FTCI-3/8D10A4P-2UP8X-H1141	0.2-4	3/8"	10	-10 to +90	PNP NO/NC	PNP NO/NC	n/a	n/a						1	
FTCI-1/2D10A4P-2UP8X-H1141	0.2-5	1/2"	10	-10 to +90	PNP NO/NC	PNP NO/NC	n/a	n/a						1	
FTCI-3/4D15A4P-2UP8X-H1141	1-12	3/4"	15	-10 to +90	PNP NO/NC	PNP NO/NC	n/a	n/a						1	
FTCI-3/8D10A4P-LI-UP8X-H1141	0.2-4	3/8"	10	-10 to +90	PNP NO/NC	4-20 mA	n/a	n/a						2	
FTCI-1/2D10A4P-LI-UP8X-H1141	0.2-5	1/2"	10	-10 to +90	PNP NO/NC	4-20 mA	n/a	n/a						2	
FTCI-3/4D15A4P-LI-UP8X-H1141	1-12	3/4"	15	-10 to +90	PNP NO/NC	4-20 mA	n/a	n/a						2	
FTCI-3/8D10A4P-4UP8X-H1160	0.2-4	3/8"	10	-10 to +90	PNP NO/NC	PNP NO/NC	PNP NO/NC	PNP NO/NC						3	
FTCI-1/2D10A4P-4UP8X-H1160	0.2-5	1/2"	10	-10 to +90	PNP NO/NC	PNP NO/NC	PNP NO/NC	PNP NO/NC						3	
FTCI-3/4D15A4P-4UP8X-H1160	1-12	3/4"	15	-10 to +90	PNP NO/NC	PNP NO/NC	PNP NO/NC	PNP NO/NC						3	
FTCI-3/4D15A4P-2LIX-H1141	1-12	3/4"	10	-10 to +84	4-20 mA	4-20 mA	n/a	n/a						4	
FCI-D10A4P-2ARX-H1160/D201	0.2-4	3/8"	10	-18 to +100	Relay NO	Relay NO	n/a	n/a						5	
FCI-D10A4P-2ARX-H1160/D203	0.2-4	3/8"	10	-18 to +100	Relay NO	Relay NO	n/a	n/a						5	
FCI-D10A4P-2ARX-H1160/D205	0.2-5	1/2"	10	-18 to +100	Relay NO	Relay NO	n/a	n/a						5	
FCI-D15A4P-2ARX-H1160/D209	1-12	3/4"	15	-18 to +100	Relay NO	Relay NO	n/a	n/a						5	

Specifications:

Electrical	
Operating Voltage	21.6-26.4 VDC
Current Consumption	<100 mA
Switching Current PNP outputs	200 mA
Analog Load 4-20 mA outputs	200-500
Switching Current/Voltage Relay Outputs	<.5 A @ 30 VDC, <1 A @ 36 VDC
Environmental	
Protection	IP65
Pressure Rating	290 PSI
Ambient Temperature	0 to 60 °C
Materials	
Housing	PBT
Wetted Parts:	
Tubing	316 TI Stainless Steel
O-ring	FKM
Operational	
Time Delay before Availability	2-15 seconds 8 seconds typical
Response time	.5-3 seconds
Maximum Temperature Change	4.2 C/second

Flow Monitors

Drawings

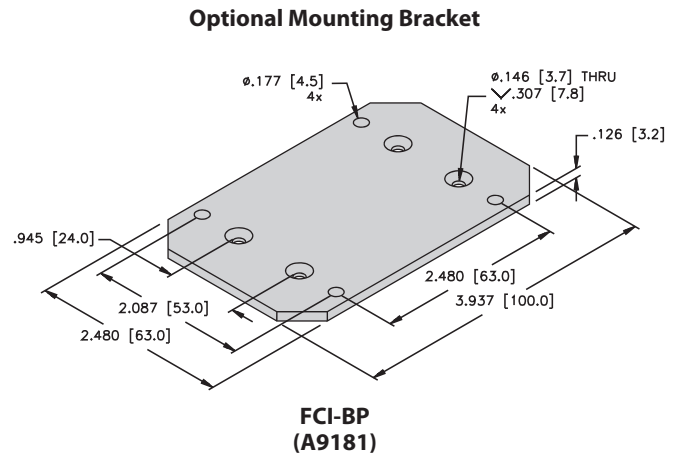
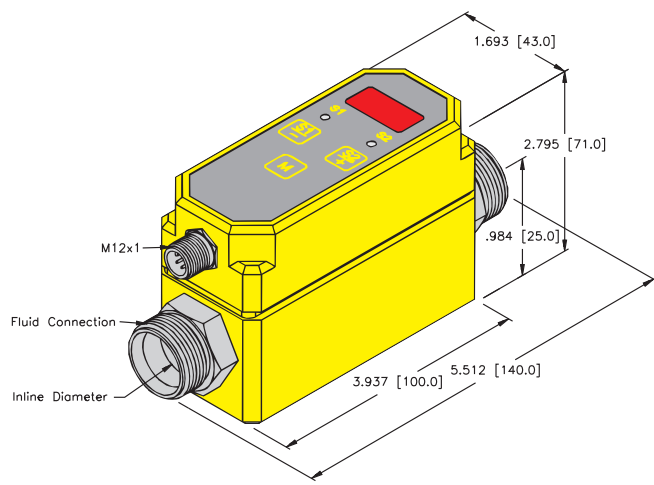

FLOW

Wiring Diagrams

Diagram 1	Diagram 2	Diagram 3	Diagram 4	Diagram 5
Mating Cordset: RK 4.4T-*	Mating Cordset: RK 4.4T-*/S618	Mating Cordset: RKC 6T-*	Mating Cordset: RK 4.4T-*/S618	Mating Cordset: RKC 6T-*

Adapter Options

Material: 316 Stainless Steel

<p>FSV-SS 3/8 KIT (2 sets) (A9183)</p>	<p>FSV-SS 1/2 KIT (2 sets) (A9184)</p>	<p>FSV-SS 3/4 KIT (2 sets) (A9185)</p>
<p>FSV-SS 3/8 TS-NPT (A9307)</p>	<p>FSV-SS 1/2 TS-NPT (A9305)</p>	<p>FSV-SS 3/4 TS-NPT (A9306)</p>

FCI INLINE FLOW MONITOR PRODUCT OVERVIEW

WHAT IS THE FCI INLINE FLOW MONITOR?

The FCI inline flow monitor operates using the calorimetric flow principle, which detects the transfer of heat in thermally conductive fluids. The temperature detecting elements are platinum RTDs. One of the elements (R1) detects the temperature of the fluid in the pipe and the resistor (R2) is connected to a heater. The heating element heats R2 to a temperature that is slightly above the temperature of the surrounding fluid. When there is no fluid flow, the difference between R1 and R2 remains constant. As the fluid moves through the sensor, heat is conducted away from the heated element causing the temperature of R2 to decrease. This heat loss causes the differential resistance input to the amplifier where the various outputs are generated. With FCI flow monitors, the temperature elements are bonded directly to the outside of a flow through tube. See probe section for more information about the calorimetric flow monitors.

WHY CHOOSE THE FCI INLINE FLOW MONITOR?

- No pressure loss
- Wide range of flow rates
- Fast response time
- Low flow rate detection and pulsed flow monitoring.
- Stackable
- Viscous fluids can flow freely through the fully ported sensor, since the flow does not need to be disrupted to be detected.

WHERE CAN I USE THE FCI INLINE FLOW MONITOR?

- Flow/no flow
- Dispensing applications
- Viscous fluids
- Low and/or pulsing flows
- Set point applications

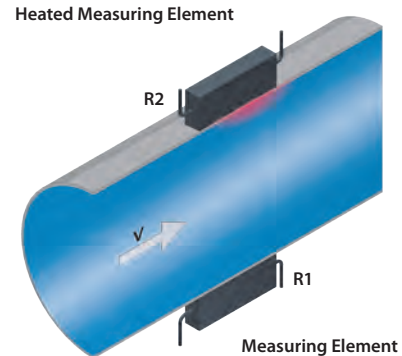

The resistance difference is measured by a Wheatstone bridge circuit. A change in resistance difference causes a change in bridge voltage. The flow set point is determined by comparing the bridge voltage to a reference voltage.

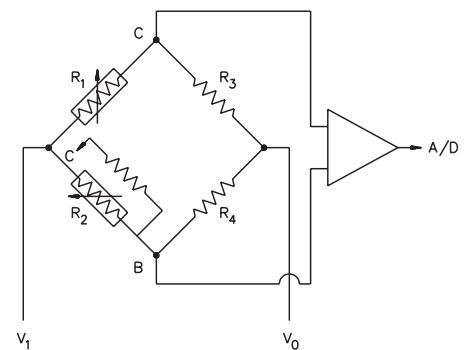

R1 - Monitors fluid temperature
R2 - Heated by heating element
R3 - Internal resistor
R4 - Internal resistor

Setup – Operating and Display Functions

Self Contained Inline



6 LEDs for flow rate status indication:

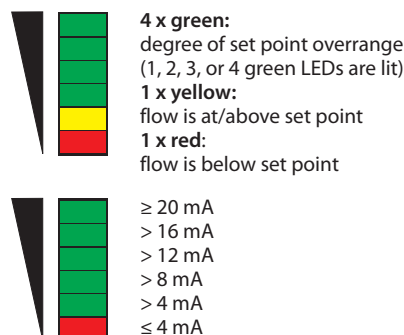

Switch Point Versions
Potentiometer for adjustment of flow switch point

Analog Versions
Potentiometer for adjusting the 4 mA to the medium

Potentiometer for adjusting the span to 20 mA (not all applications may reach 20 mA)

Flow Monitors

Inline Flow Sensor Part Number Key



<p>Sensor Type</p> <p>FCI = Inline Flow Sensor</p>	<p>Fluid Connection</p> <p>TC = Tubing Connection N1/8 = 1/8 NPT N1/4 = 1/4 NPT N3/4 = 3/4 NPT Blank = G1/4</p>	<p>Inline Diameter (millimeters)</p> <p>D03 = 3 mm D04 = 4 mm D06 = 6 mm D08 = 8 mm D09 = 9 mm D10 = 10 mm D11 = 11 mm D20 = 20 mm</p>	<p>Electrical Connection</p> <p>H1141 = <i>eurofast</i>®, 4-pin H1140 = <i>eurofast</i>, 4-pin H1160 = <i>eurofast</i>, 6-pin</p>	<p>Circuitry</p> <p>AP8X = N.O. PNP AN8X = N.O. NPN ARX = N.O. Relay RRX = N.C. Relay LIX = 4-20 mA NA = Requires Remote Amplifier NAEX = Intrinsically Safe Requires Remote Amplifier</p>	<p>Housing</p> <p>A4 = 316 Stainless Steel A4P = 316 Stainless Steel with PBT Housing CTP = Ceramic / PTFE / PBT HC22 = Hastelloy C22</p>
---	--	--	--	---	---

FLOW

Special Option Codes

D Number

/D038 = 3/8 in. Tubing Connection
 /D014 = Tri-Clamp Connection
 /A = Airflow

/D..

TURCK

Flow Monitors

Flow monitors for Water and Oils

- IP67
- Flow rates as low as 1 ml/min
- Great for Stamping Press Lubrication Oil Monitoring,

Weld Tip Protection, Pump Run Dry Protection, and other monitoring applications.

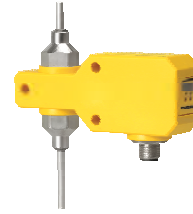

Part Number	Flow Detection Range Water (ml/min)	Flow Detection Range (ml/min) oil	Fluid Connection	Media Temperature (°C)	Output	Pressure Rating (PSI)	Wiring	Drawing
FCI-TCDO4A4P-LIX-H1141	1-200	Consult Factory	4 mm Tube	0 to 60	4-20 mA Non-linear Analog	14.5	1	1
FCI-TCDO4A4P-AP8X-H1141	1-200	Consult Factory	4 mm Tube	0 to 60	PNP N.O.	14.5	2	1
FCI-TCDO4A4P-ARX-H1140	1-200	Consult Factory	4 mm Tube	0 to 60	Relay N.O.	14.5	3	1
FCI-1/4TCDO4A4P-LIX-H1141	1-200	Consult Factory	1/4" reinforced tube	0 to 60	4-20 mA Non-linear Analog	145	1	2
FCI-1/4TCDO4A4P-AP8X-H1141	1-200	Consult Factory	1/4" reinforced tube	0 to 60	PNP N.O.	145	2	2

Specifications:

Electrical	
Operating Voltage	21.6-26.4 VDC
Current Consumption	<50 mA
Switching Current PNP outputs	200 mA
Analog Load 4-20 mA outputs	200-500
Switching Current/Voltage Relay Outputs	<1A at 30 VAC, <1A at 36 VDC
Environmental	
Protection	IP67
Ambient Temperature	0 to 60 °C
Materials	
Housing	PBT
Cable Connector	303 Stainless Steel
Wetted Parts:	
Tubing	316 TI Stainless Steel
Time Delay before Availability	5-15 seconds, 8 seconds typical
Response time	0.5-3 seconds
Maximum Temperature Change	6.6 C/second

Flow Monitors

Drawings

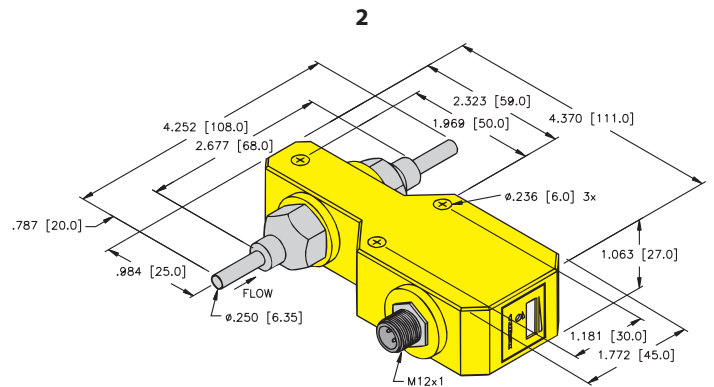
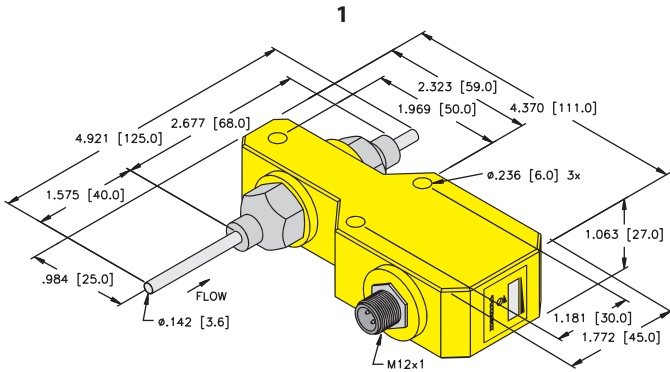

FLOW

Wiring Diagrams

Diagram 1

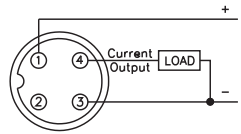

Mating Cordset:
RK 4T-*/S618

Diagram 2

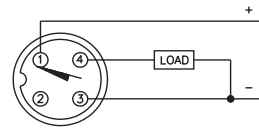

Mating Cordset:
RK 4T-*

Diagram 3

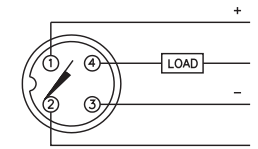

Mating Cordset:
RK 4.4T-*

TURCK

Flow Monitors

Inline Flow Monitors

- Great for water and Oil
- IP67
- LED visualization of flow rate
- Great for Stamping Press Lubrication Oil Monitoring,

Weld Tip Protection, Pump Run Dry Protection, and other monitoring applications



Part Number	Flow Detection Range Water (lpm)	Flow Detection Range Oil (lpm)	Fluid Connection	Media Temperature (°C)	Output: Flow	Current Consumption	Wiring	Adapter Color Code	Drawing
FCI-D04A4P-AP8X-H1141	.015-1	Consult Factory	G 1/4"	0 to 80	PNP N.O.	<50 mA	1		1
FCI-D04A4P-LIX-H1141	.015-1	Consult Factory	G 1/4"	0 to 80	4-20 mA Non-Linear Analog	<50 mA	2		1
FCI-D08A4P-ARX-H1140/D038	1-6	Consult Factory	3/8" swage	0 to 80	Relay N.O.	<50 mA	3		4
FCI-D10A4P-AP8X-H1141	1-6	Consult Factory	G 1/4"	0 to 80	PNP N.O.	<50 mA	1		1
FCI-D10A4P-ARX-H1140	1-6	Consult Factory	G 1/4"	0 to 80	Relay N.O.	<50 mA	3		1
FCI-D10A4P-LIX-H1141	1-6	Consult Factory	G 1/4"	0 to 80	4-20 mA Non-Linear Analog	<50 mA	2		1
FCI-D15A4P-ARX-H1140	3-20	Consult Factory	G 1/2"	-20 to 80	Relay N.O.	<50 mA	3		2
FCI-D15A4P-LIX-H1141	3-20	Consult Factory	G 1/2"	-20 to 80	4-20 mA Non-Linear Analog	<50 mA	2		2
FCI-N3/4D20A4P-AP8X-H1141	4-30	Consult Factory	3/4" NPT	0 to 80	PNP N.O.	<60 mA	1		3
FCI-N3/4D20A4P-LIX-H1141	4-30	Consult Factory	3/4" NPT	0 to 80	4-20 mA Non-Linear Analog	<60 mA	2		3
FCI-N3/4D20A4P-ARX-H1140	4-30	Consult Factory	3/4" NPT	0 to 80	Relay N.O.	<60 mA	3		3

Specifications:

Electrical	
Operating Voltage	21.6-26.4 VDC
Switching Current PNP outputs	200 mA
Analog Load 4-20 mA outputs	200-500
Switching Current/Voltage Relay Outputs	<1A at 30 VDC, <1A at 36 VAC
Environmental	
Protection	IP67
Pressure Rating	290 PSI
Ambient Temperature	0 to 60 °C
Materials	
Housing	PBT
Cable Connector	303 Stainless Steel
Wetted Parts:	
Tubing	316 TI Stainless Steel
Operational	
Time Delay before Availability	5-15 seconds 8 seconds typical
Response time	0.5-3 seconds
Maximum Temperature Change	6.6 C/second

Flow Monitors

Drawings

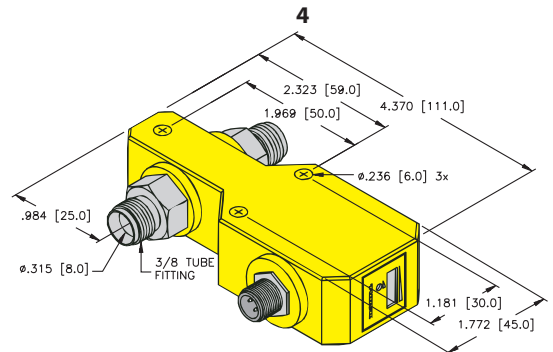
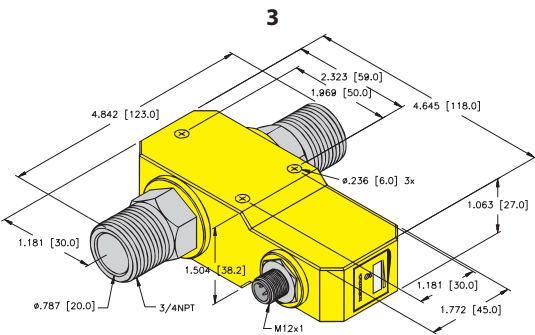
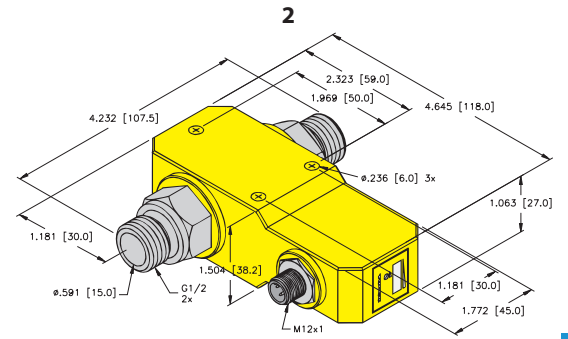
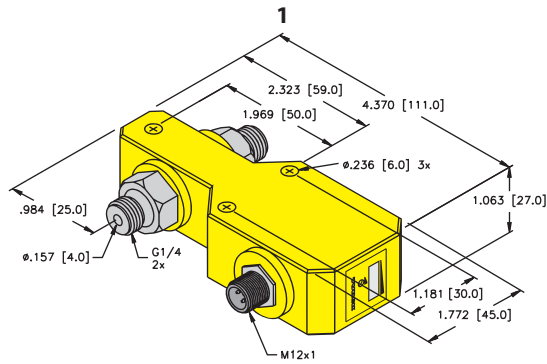

FLOW

Wiring Diagrams

Diagram 1

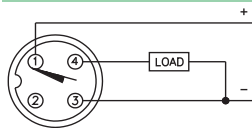

Mating Cordset:
RK 4T-*

Diagram 2

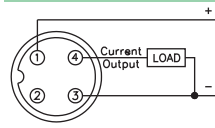

Mating Cordset:
RK 4T-*/S618

Diagram 3

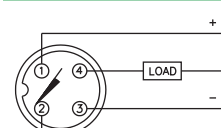

Mating Cordset:
RK 4.4T-*

Adapter Options

FSV-SS-1/8x1/4
(A2535)

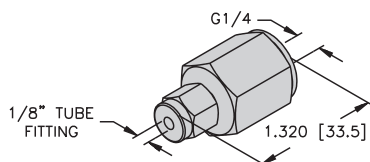

FSV-SS-1/4x1/4
(A2534)

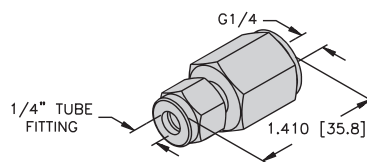

FSV-SS 3/8 KIT (2 sets)
(A9183)

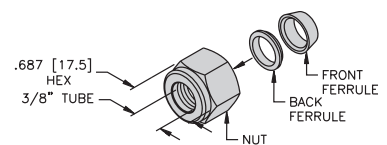

FSV-SS-3/8x1/4
(A2533)

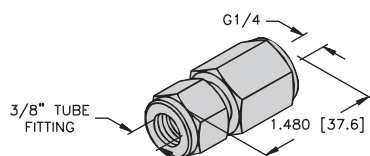

FSV-SS-1/2x1/4
(A2536)

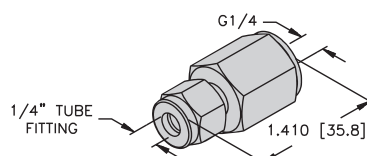

FSV-SS 3/8 TS-NPT
(A9307)

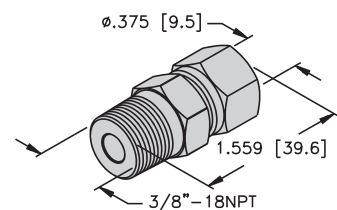

TURCK

Flow Monitors

Inline Flow Monitors Chemical Resistant

- IP67
- LED visualization of flow rate
- Great for acids, chemicals, and flow/no flow or setpoint applications



Part Number	Flow Detection Range Water (ml/min)	Flow Detection Range Oil	Wetted Materials	Fluid Connection	Media Temperature (°C)	Output: Flow	Pressure Rating	Wiring	Drawing
FCI-N1/4D04HC22P-AP8X-H1141	15-1000	Consult Factory	Hastelloy C22	1/4" NPT	0 to 60	PNP N.O.	290	1	1
FCI-N1/4D10HC22P-AP8X-H1141	100-6000	Consult Factory	Hastelloy C22	1/4" NPT	0 to 60	PNP N.O.	290	1	1
FCI-N1/8D06CTP-ARX-H1140	20-3000	Consult Factory	PTFE, Viton, Al2O3 Ceramic	1/8" NPT Female	0 to 60	Relay N.O.	72.5	2	2
FCI-N1/8D06CTP-AP8X-H1141	20-3000	Consult Factory	PTFE, Viton, Al2O3 Ceramic	1/8" NPT Female	0 to 60	PNP N.O.	72.5	1	2

Specifications:

Electrical	
Operating Voltage	21.6-26.4 VDC
Current Consumption	<50 mA
Switching Current PNP outputs	200 mA
Analog Load 4-20 mA outputs	200-500
Switching Current Relay Outputs	<1A at 60 VDC
Environmental	
Protection	IP67
Ambient Temperature	0 to 60 °C
Materials	
Housing	PBT
Cable Connector	303 Stainless Steel
Operational	
Time Delay before Availability	5-15 seconds 8 seconds typical
Response time	0.5-3 seconds
Maximum Temperature Change	6.6 C/second

Flow Monitors

Drawings

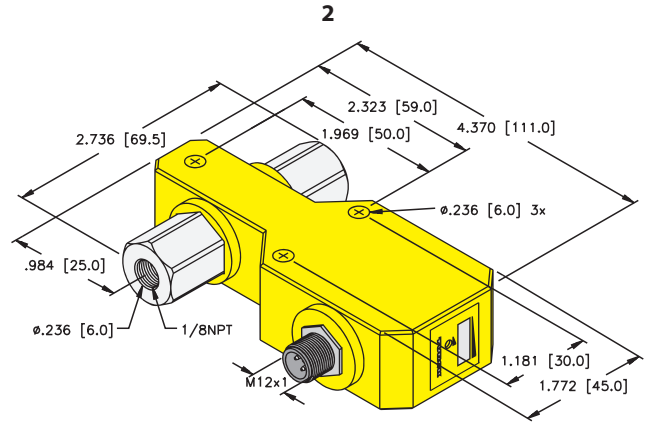
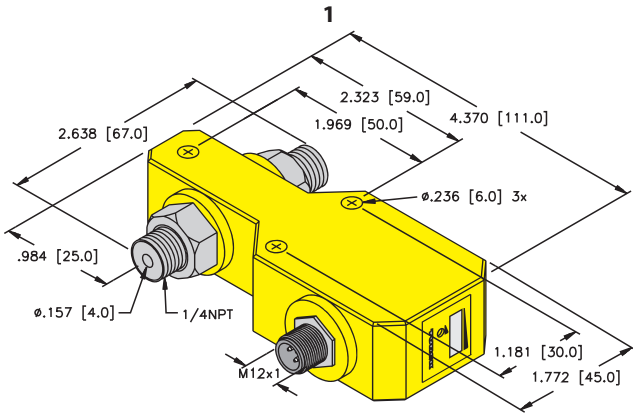

FLOW

Wiring Diagrams

Diagram 1

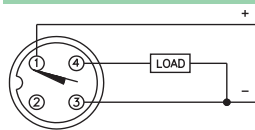

Mating Cordset:
RK 4T - *

Diagram 2

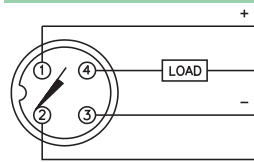

Mating Cordset:
RK 4.4T - *

TURCK

Flow Monitors

Remote Amplified Inline Flow Monitors

- Choose your output by selecting an amplifier
- IP67



Part Number	Flow Detection Range Water (ml/min)	Flow Detection Range Oil (ml/min)	Fluid Connection	Ambient Temperature (°C)	Media Temperature (°C)	Pressure Rating (PSI)	Housing Material	Intrinsically Safe EEx ib IIC T6, for use hazardous zone 1	Wiring	Adapter Color Code Drawing #
FCI-D04A4P-NA-H1141	15-800	Consult Factory	G 1/4"	-20 to 70	0 to 80	290	PBT		1	1
FCI-D10A4P-NA-H1141	200-6000	Consult Factory	G 1/4"	-20 to 70	0 to 80	290	PBT		1	2
FCI-D08A4P-NA-H1141/D038	200-6000	Consult Factory	3/8" swage	-20 to 70	0 to 80	290	PBT		1	3
FCI-D09A4-NA-H1141/M16	30-900	90-1800	M16x1.5	-25 to 70	-20 to 80	145	316 Ti SS		1	5
FCI-D03A4-NA-H1141/M16	5-150	15-300	M16x1.5	-25 to 70	-20 to 80	145	316 Ti SS		1	5
FCI-D09A4-NAEX-H1141/M16	50-900	150-1800	M16x1.5	-25 to 60	-20 to 70	87	316 Ti SS		2	5
FCI-D03A4-NA-H1141/M12	5-150	15-300	M12x1.5	-25 to 70	-20 to 80	145	316 Ti SS		1	4

Specifications:

Electrical	
"NA" outputs require a "non-EX" remote amplifier	See page 49 for part numbers
"NAEX" outputs require an "EX" remote amplifier	
Environmental	
Protection	IP67
Ambient Temperature	-20 to 70 °C
Materials	
Wetted Parts	316 Ti Stainless Steel
Cable Connector	303 Stainless Steel
Operational	
Time Delay before Availability	2-15 seconds 8 seconds typical
Response time	1-13 seconds, 2 seconds typical

Flow Monitors

Drawings

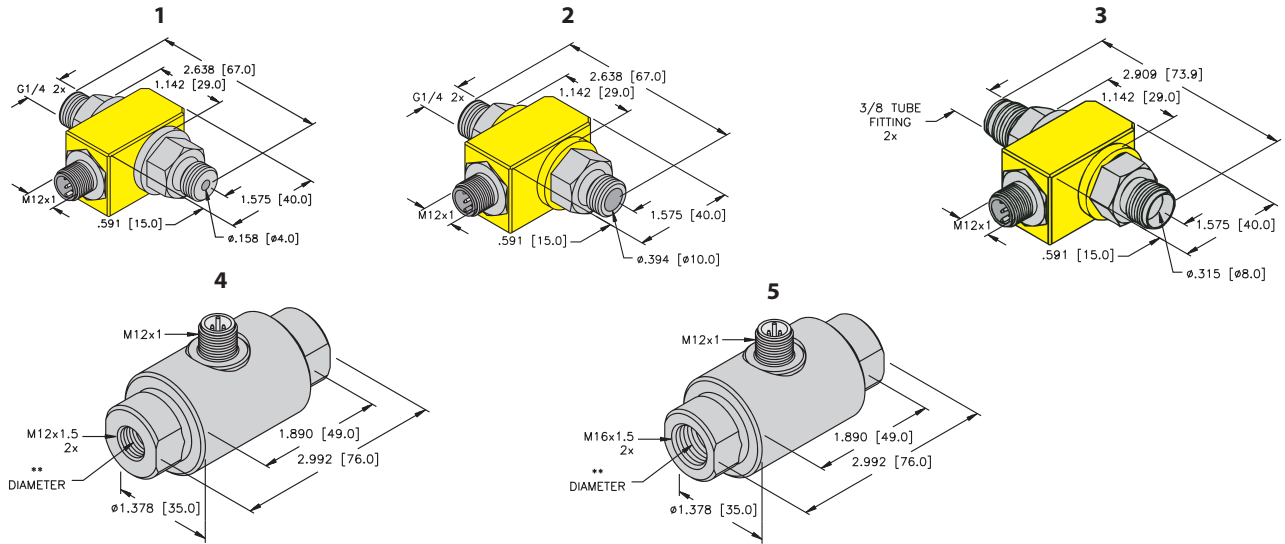

Wiring Diagrams



Adapter Options

Material: 316 Stainless Steel.

FSV-SS-3/8 kit (A9183)

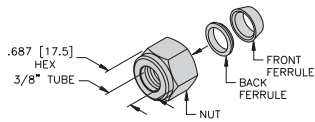

Adapter G1/4 to 1/8 in. Tubing FSV-SS-1/8X1/4 (A2535)

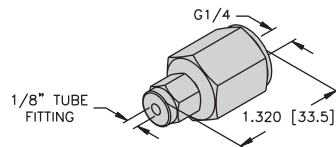

Adapter G1/4 to 1/4 in. Tubing FSV-SS-1/4X1/4 (A2534)

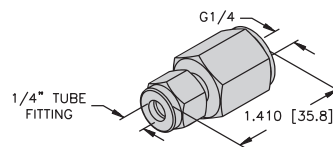

Adapter G 1/4 to 3/8 in. Tubing FSV-SS-3/8X1/4 (A2533)

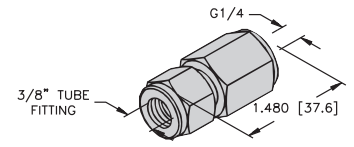

Adapter G1/4 to 1/2 in. Tubing FSV-SS-1/2X1/4 (A2536)

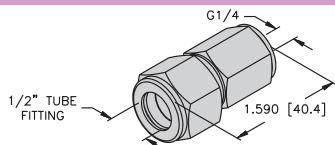

FCS PROBE FLOW MONITOR

PRODUCT OVERVIEW

WHAT IS A FCS PROBE STYLE FLOW MONITOR?

Probe style flow monitors detect the speed of liquids and gases without using mechanical parts. These solid state flow monitors operate on the calorimetric principle: the measure of heat transfer from an object to a fluid.

The TURCK solid state flow monitors use two temperature dependent resistors. One of the resistors (R1) monitors the temperature of the surrounding fluid. The other resistor (R2) is connected to a heating element. The heating element heats R2 to a temperature that is slightly above the surrounding fluid temperature. When there is no fluid flow, the difference in resistance between R1 and R2 is a fixed value. As fluid moves over the flow monitor probe, heat is conducted away from the heating element causing the temperature on R2 to decrease. This heat loss changes the difference in resistance between R1 and R2.

The resistance difference is measured by a Wheatstone bridge circuit. A change in resistance difference causes a change in the bridge voltage. The flow set point is determined by comparing the bridge voltage to a reference voltage.

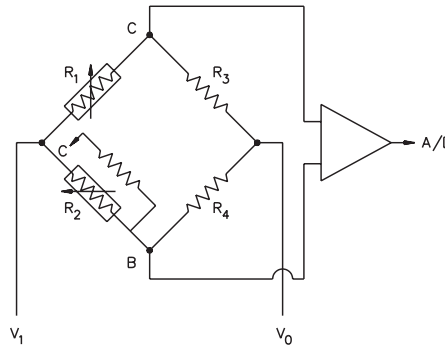
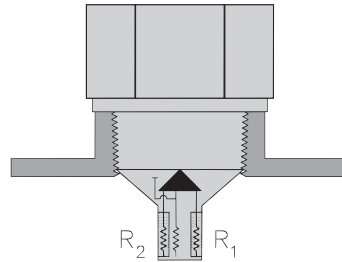

R1 - Monitors fluid temperature
R2 - Heated by heating element
R3 - Internal resistor
R4 - Internal resistor

Operating Range

Heat loss on the heating element will likewise determine the sensitivity of the monitor. The heat loss becomes a function of flow velocity and thermal conductivity of the fluid. The lower the thermal conductivity of the fluid, the faster the fluid has to flow to be detected.

Flow monitor operating ranges vary from one type of fluid to another. These operating ranges are proportional to the speed of the fluid that the monitor can detect. For example, at the same flow rate, air can conduct only a fraction of the heat away from the heating element compared to water.

Response Time

The switch-on time is the time required for the flow monitor to detect and indicate that the flow speed is increasing.

The switch-off time is the time required for the flow monitor to detect and indicate that the flow speed is decreasing.

Time Delay Before Availability

The availability is the time required, after power has been applied, for the flow monitor to reach a stable operating condition. The availability provides the time needed to energize the flow monitor and for the flow monitor to stabilize at the fluids temperature.

Effects of Housing Material

The response time and temperature gradient is dependent on the housing material. Flow monitors that use PTFE have a low thermal conductivity causing a slower response time to fluid temperature changes and to changes in the flow speed.

FCS PROBE FLOW MONITOR

PRODUCT OVERVIEW

WHY CHOOSE A FCS PROBE STYLE FLOW MONITOR?

Temperature Gradient

The temperature gradient of a fluid indicates the change in fluid temperature within a specified time (unit of measure: °C (°F)/min). The temperature gradient of a device defines the maximum temperature rise that can be compensated by the monitor without malfunction.

The monitor has the ability to compensate for sudden thermal shifts within the specified extremes. Sudden temperature changes exceeding the specified tolerances (temperature error) may cause the device to malfunction. Only when the monitor has adapted to the new temperature, will it provide an accurate measurement.

The temperature gradient for TURCK flow monitors is 4°C/second. This is 15 times higher than standard flow devices, which makes for a particularly accurate switch-point stability during variations in temperature.

The sensitivity to temperature rise of TURCK flow monitors has been reduced to a minimum (<12 s) and can accurately be determined in advance.

Graph 1 can be used to determine if the TURCK flow monitor can compensate for a temperature change to a sensed medium. The dotted line in the graph indicates that a 10°C change has occurred in a time period of 5 seconds. Points (5,10) intersect in the "No False Output" region of the graph. This example illustrates an acceptable degree of temperature change in the application. As a result, the flow monitor can compensate for the fluid temperature change.

$$\text{Fahrenheit} = (1.8 \times \text{°C}) + 32$$

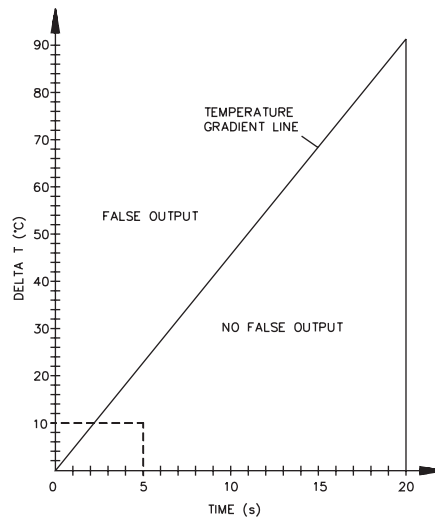

Graph 1 – Temperature gradient for stainless steel housing

WHERE CAN I USE A FCS PROBE STYLE FLOW MONITOR?

- Large pipes: probe lengths available for up to 220 mm
- Flow/no flow detection
- Set point applications
- Linear analog for water applications
- High pressure, intrinsically safe, plastic versions
- Pump run dry protection

FCS PROBE FLOW MONITOR PRODUCT OVERVIEW

Mounting Instructions

Areas of turbulent flow occur whenever there is a change in the pipe construction (e.g. pipe inlets, pipe outlets, pipe elbows). To avoid an inaccurate output, the following guidelines should be observed:

A) Pay special attention to the minimum distance ($a \geq 4xd$) to tube bend and intersections.

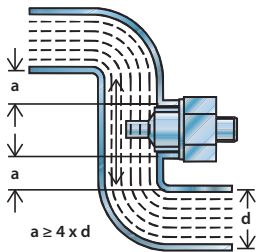

Proper Orientation For
Self-Contained Metal Housing

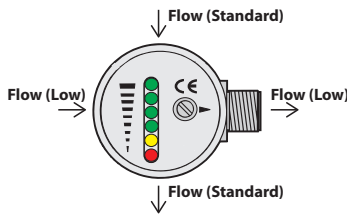

B) Flow monitor must be mounted from below in applications where medium does not completely fill the pipe.

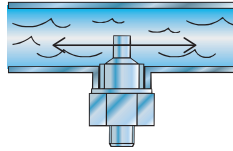

Proper Orientation For
Self-Contained Plastic Housing

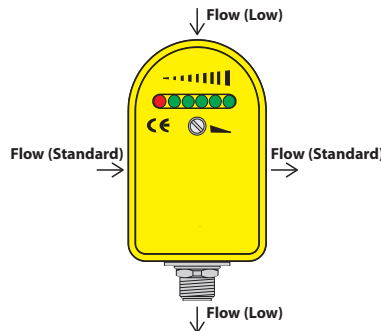

C) If a possibility of deposit build-up exists, mount the flow

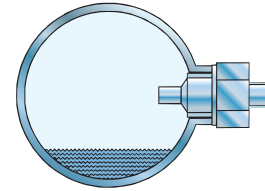

Proper Orientation For
Remote Insertion Probe

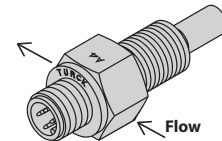

Setup – Operating and Display Functions

Self Contained Insertion Probe



6 LEDs for flow rate status indication:

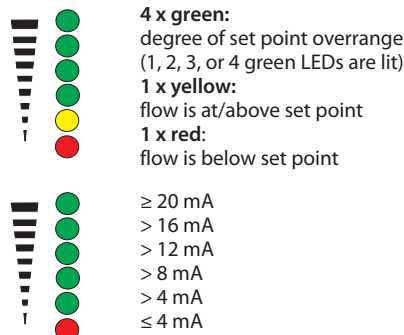

Sealing screw (on front of device)
covers the potentiometer.

Potentiometer for the adjustment
of flow switch point. With analog
devices the potentiometer is used
to set the measuring range.

Flow Monitors

Flow Monitor Part Number Key - Insertion Probe Sensor



Sensor Type	Fluid Connection	Housing	Special Option Codes	Electrical Connection	Circuitry
FCS = Insertion Probe Flow Sensor FTCS = Flow Sensor with Temperature Setpoint	N1/2 = 1/2 NPT N3/4 = 3/4 NPT G1/4 = G1/4 (1/4 BSPP) G1/2 = G1/2 (1/2 BSPP) GL1/2 = G1/2 (1/2 BSPP with additional threading) 50 = 1.5 inch Tri-clamp	A4 = 316 Stainless Steel Housing and Probe A2P = 303 Stainless Steel Probe with PBT Housing A4P = 316 Stainless Steel Probe with PBT Housing AL = 303 Stainless Steel Probe HB = Hastelloy B HC22 = Hastelloy C22 T = Dyflor (PVDF) TN = Titanium w/B3 Coating	/A = Airflow /L = Probe Length in mm /D100 = +120°C (+248°F) /D500 = 500 Bar rating /D014 = Tri-clamp fitting	H1141 = eurofast [®] H1140 = eurofast B1151 = minifast [®] B3141 = microfast [®] B3151 = microfast	2AP8X = Dual N.O. PNP AP8X = N.O. PNP AN8X = N.O. NPN ARX = N.O. Relay RRX = N.C. Relay LIX = 4-20 mA NA = Remote (requires MK or MS 96) NAEX = Intrinsically Safe

FLOW

TURCK

Flow Monitors

Probe style Flow Monitors

- Great for water or Oil
- IP65
- LED visualization of flow rate
- Great for Stamping Press Lubrication
Oil Monitoring, Weld Tip Protection,
Pump Run Dry Protection, and other
monitoring applications



Part Number	Flow Detection Range, Water (cm/s)	Flow Detection Range, Oil (cm/s)	Operating Voltage	Current Consumption	Fluid Connection	Output: Flow	Probe Length (mm)	Wiring	Optional Adapters Drawing
FCS-N1/2A4P-AP8X-H1141	5-150	10-300	24 VDC +/-10%	100	1/2" NPT	PNP N.O.	42	2	1
FCS-N1/2A4P-LIX-H1141	5-150	N/A	24 VDC +/-10%	100	1/2" NPT	4-20 mA Linear Analog	42	1	3
FCS-N1/2A4P-LIX-H1141/D037	5-150	10-300	24 VDC +/-10%	100	1/2" NPT	4-20 mA Non-Linear Analog	42	1	3
FCS-G1/2A4P-AP8X-H1141	1-150	3-300	24 VDC +/-10%	60	G 1/2"	PNP NO	31	2	2
FCS-N1/2A4P-AP8X-H1141/L060	1-150	3-300	24 VDC +/-10%	60	1/2" NPT	PNP N.O.	60	2	1
FCS-N1/2A4P-AP8X-H1141/L100	1-150	3-300	24 VDC +/-10%	60	1/2" NPT	PNP N.O.	100	2	1
FCS-N1/2A4P-AP8X-H1141/L120	1-150	3-300	24 VDC +/-10%	60	1/2" NPT	PNP N.O.	120	2	1
FCS-N1/2A4P-ARX-B1151 115VAC	1-150	3-300	115 VAC +/-15%	60	1/2" NPT	Relay N.O.	42	3	4
FCS-N1/2A4P-RRX-B1151 115VAC	1-150	3-300	115 VAC +/-15%	60	1/2" NPT	Relay N.C.	42	4	4
FCS-N1/2A4P-ARX-B1151 230VAC	1-150	3-300	230 VAC +/-15%	30	1/2" NPT	Relay N.O.	42	7	4
FCS-N1/2A4P-ARX-B1151/L060/115VAC	1-150	3-300	115 VAC +/-15%	60	1/2" NPT	Relay N.O.	60	3	4
FCS-N1/2A4P-ARX-B1151/L080/115VAC	1-150	3-300	115 VAC +/-15%	60	1/2" NPT	Relay N.O.	80	3	4
FCS-N1/2A4P-ARX-B1151/L100/115VAC	1-150	3-300	115 VAC +/-15%	60	1/2" NPT	Relay N.O.	100	3	4
FCS-N1/2A4P-ARX-B1151/L120 115VAC	1-150	3-300	115 VAC +/-15%	60	1/2" NPT	Relay N.O.	120	3	4
FCS-N1/2A4P-ARX-B1151/L160/115VAC	1-150	3-300	115 VAC +/-15%	60	1/2" NPT	Relay N.O.	160	3	4
FCS-N1/2A4P-ARX-B3141 115VAC	1-150	3-300	115 VAC +/-15%	60	1/2" NPT	Relay N.O.	42	5	5
FCS-N1/2A4P-ARX-B3141/L060 115VAC	1-150	3-300	115 VAC +/-15%	60	1/2" NPT	Relay N.O.	60	5	5
FCS-N1/2A4P-ARX-B3151 115VAC	1-150	3-300	115 VAC +/-15%	60	1/2" NPT	Relay N.O.	42	6	5

Specifications

Electrical	
Switching Current PNP outputs	400 mA
Analog Load 4-20 mA outputs	500
Switching Current Relay Outputs	2A at 60 VDC
Environmental	
Protection	IP65
Pressure Rating	1450 PSI
Ambient Temperature	-20 to 70 °C
Media Temperature	-20 to 80 °C

Materials	
Housing	PBT
Cable Connector	303 Stainless Steel
Wetted Parts	316 Ti Stainless Steel
Operational	
Time Delay before Availability	2-15 seconds 8 seconds typical
Response time	1-15 seconds, 2 seconds typical
Response time	1-13 seconds, 2 seconds typical
Maximum Temperature Change	4.2 °C/second

Flow Monitors

Drawings

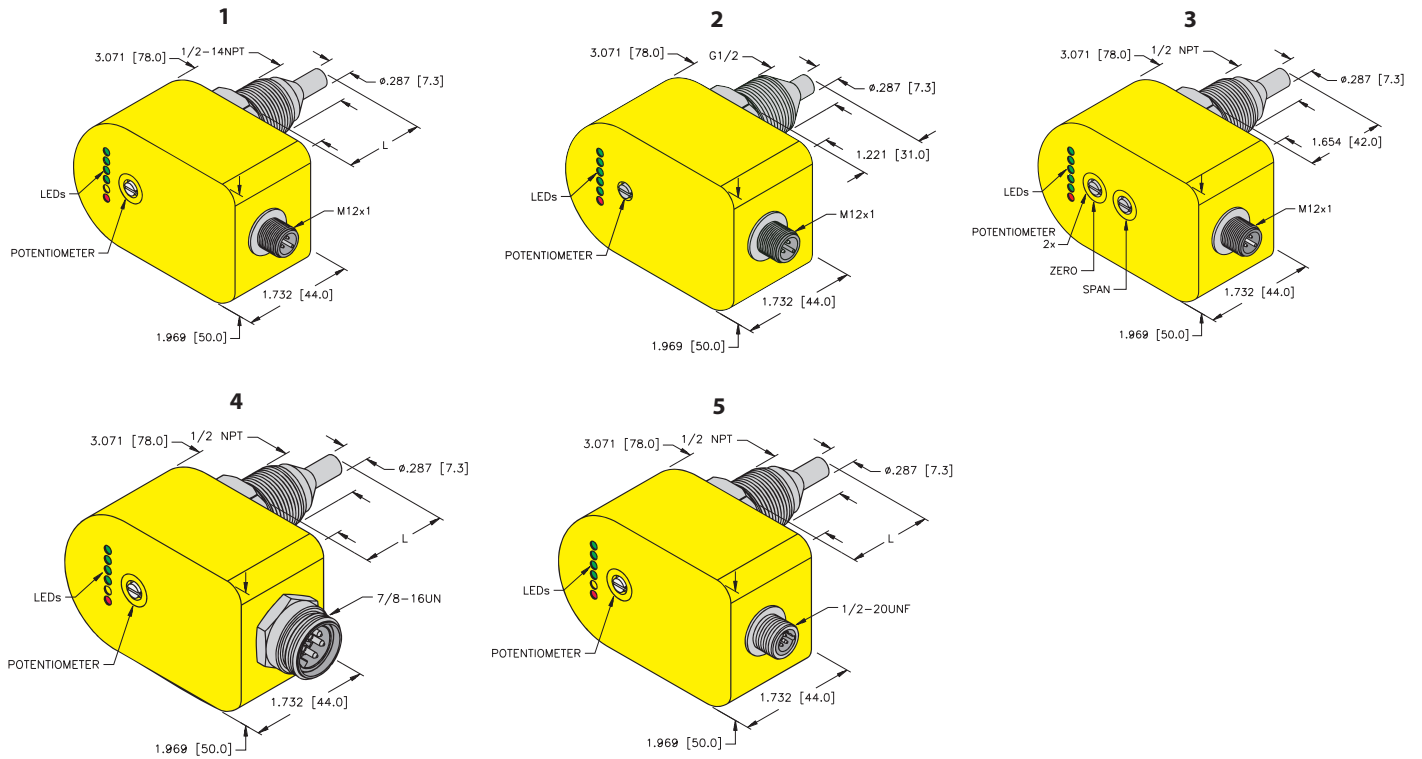

L = Probe length

Wiring Diagrams

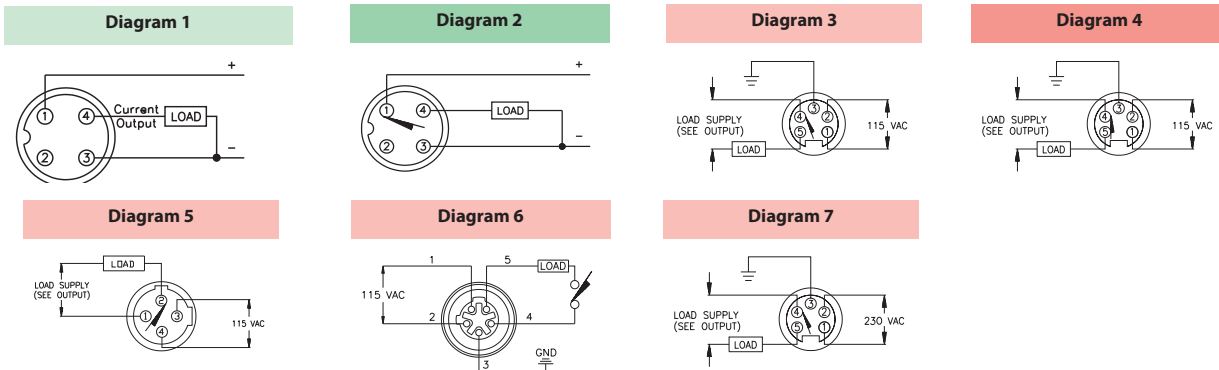

Adapter Options

G 1/2 Gasket
FD-G1/2AFM30/34 (M6875013)

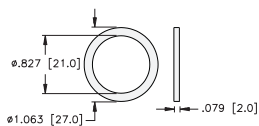

Pipe Tee (Stainless Steel)
N1/2-G1/2-SST (A6060)

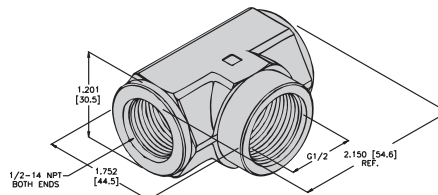

TURCK

Flow Monitors

Probe style Dual Set Point Flow Monitors

- Great for water and oil
- IP65
- LED visualization of flow rate



Part Number	Flow Detection Range Water (cm/s)	Flow Detection Range Oil (cm/s)	Operating Voltage	Fluid Connection	Output 1: Flow	Output 2	Probe Length (mm)	Wiring	Drawing
FCS-N1/2A4P-2AP8X-H1140	1-150	Consult Factory	24 VDC +/-10%	1/2" NPT	PNP N.O.	Flow: PNP N.O.	42	1	1
FTCS-N1/2A4P-2AP8X-H1140	1-150	3-300	24 VDC +/-10%	1/2" NPT	PNP N.O.	Temperature: PNP N.O. 0 to 80°C	42	2	2

Specifications:

Electrical	
Current Consumption	60 mA
Switching Current PNP outputs	400 mA
Environmental	
Protection	IP65
Pressure Rating	1450 PSI
Ambient Temperature	-20 to 70 °C
Media Temperature	-20 to 80 °C
Materials	
Housing	PBT
Cable Connector	303 Stainless Steel
Wetted Parts	316 Ti Stainless Steel
Operational	
Time Delay before Availability	2-15 seconds 8 seconds typical
Response time	1-15 seconds, 2 seconds typical
Response time	1-13 seconds, 2 seconds typical
Maximum Temperature Change	4.2 °C/second

Flow Monitors

Drawings

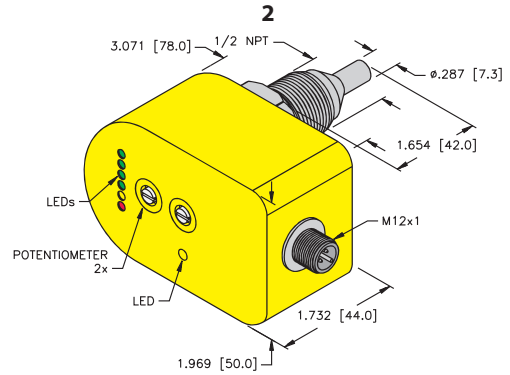
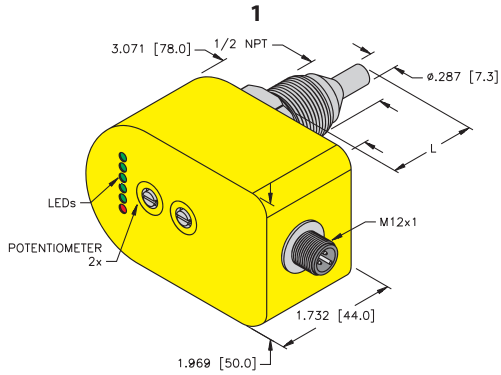

L = Probe length

Wiring Diagrams

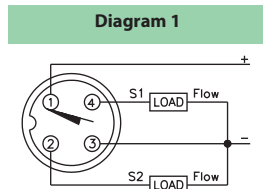

Mating Cordset:
RK 4.4T - *

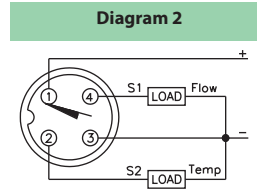

Mating Cordset:
RK 4.4T - *

FLOW

TURCK

Flow Monitors

Stainless Steel Flow Monitors

- Great for water or oil
- IP67
- LED visualization of flow rate
- Great for Stamping Press Lubrication oil Monitoring,

Weld Tip Protection, Pump Run Dry Protection, and other monitoring applications



Part Number	Flow Detection Range (cm/s)		Fluid Connection	Output: Flow	Probe Length (mm)	Wiring		
	Water	Oil				Adapter	Drawing	
FCS-N1/2A4-AN8X-H1141	1-150	3-300	1/2" NPT	NPN N.O.	40	2		1
FCS-N1/2A4-AP8X-H1141	1-150	3-300	1/2" NPT	PNP N.O.	40	1		1
FCS-N1/2A4-AP8X-H1141/L060	1-150	3-300	1/2" NPT	PNP N.O.	60	1		1
FCS-N1/2A4-AP8X-H1141/L100	1-150	3-300	1/2" NPT	PNP N.O.	100	1		1
FCS-N1/2A4-ARX-H1140	1-150	3-300	1/2" NPT	Relay N.O.	40	3		1
FCS-GL1/2A4-AP8X-H1141	1-150	3-300	GL 1/2"	PNP N.O.	48	1		2
FCS-G1/2A4-AP8X-H1141	1-150	3-300	G 1/2"	PNP N.O.	30	1		3
FCS-G1/2A4-AP8X-H1141/L080	1-150	3-300	G 1/2"	PNP N.O.	80	1		3
FCS-G1/4A4-AP8X-H1141	1-150	3-300	G 1/4"	PNP N.O.	25	1		4
FCS-G1/4A4-ARX-H1140	1-150	3-300	G 1/4"	Relay N.O.	25	3		4

Specifications:

Electrical	
Operating Voltage	24 VDC +/-10%
Switching Current PNP outputs	400 mA
Switching Current Relay Outputs	1 A at 60 VDC
Current Consumption	70 mA
Environmental	
Protection	IP67
Pressure Rating	1450 PSI
Ambient Temperature	-20 to 70 °C
Media Temperature	-20 to 80 °C
Materials	
Housing	316 Stainless Steel
Cable Connector	303 Stainless Steel
Wetted Parts	316 Ti Stainless Steel
Operational	
Time Delay before Availability	2-15 seconds 8 seconds typical
Response time (DC)	1-15 seconds, 2 seconds typical
Maximum Temperature Change	4.2 °C/second

Flow Monitors

Drawings

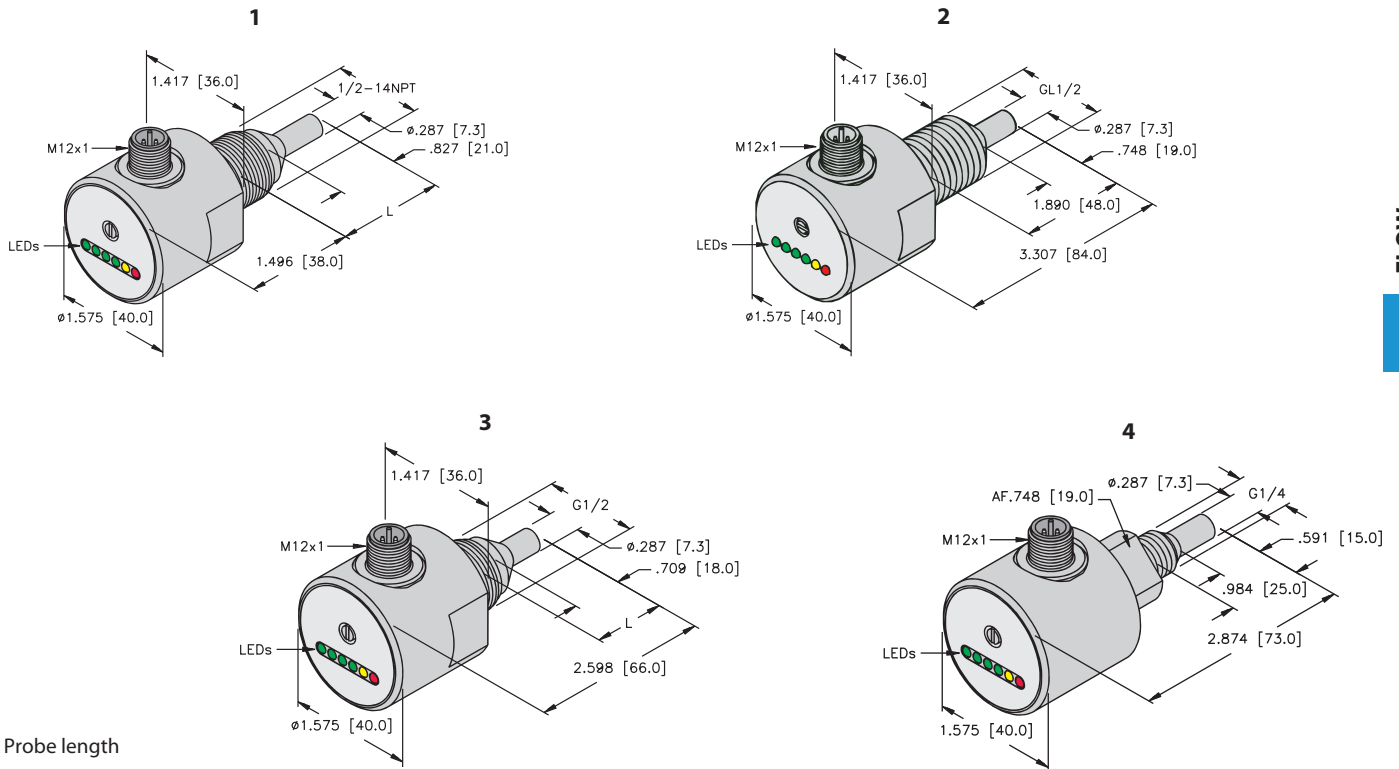

FLOW

Wiring Diagrams

Diagram 1

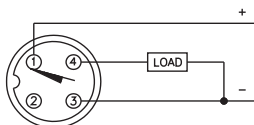

Mating Cordset: RK 4T-*

Diagram 2

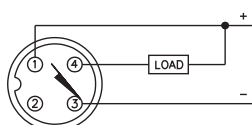

Mating Cordset: RK 4T-*

Diagram 3

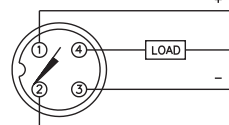

Mating Cordset: RK 4.4T-*

Adapter Options

Additional G 1/4 Gasket
FD-G1/4AFM30/34 (M6875010)

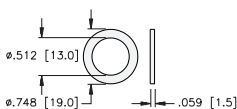

Additional G 1/2 Gasket
FD-G1/2AFM30/34 (M6875013)

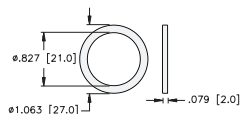

Pipe Tee (Stainless Steel)
N1/2-G1/2-SST (A6060)

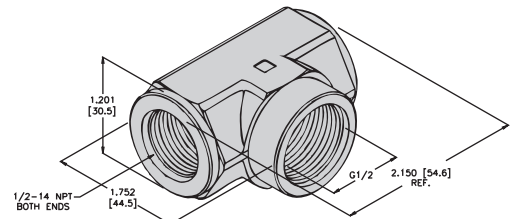

TURCK

Flow Monitors

Tri-clamp style Flow Monitors

- IP67
- LED visualization of flow rate
- 3A approved for Food and Beverage applications



Part Number	Flow Detection Range Water (cm/s)	Flow Detection Range Oil (cm/s)	Fluid Connection	Output: Flow	Probe Length (mm)	Wiring	Drawing #
FCS-50A4-AP8X-H1141/D014	1-150	3-300	1.5" tri-clamp	PNP N.O.	52	1	1
FCS-64A4-AP8X-H1141/D014	1-150	3-300	2" tri-clamp	PNP N.O.	52	1	2

Specifications:

Electrical	
Operating Voltage	24 VDC +/-10%
Switching Current PNP outputs	400 mA
Current Consumption	70 mA
Environmental	
Protection	IP67
Pressure Rating	1450 PSI
Ambient Temperature	-20 to 80 °C
Media Temperature	0 to 80 °C; 100 C for 10 minutes without damage
Materials	
Housing	316 Stainless Steel
Cable Connector	303 Stainless Steel
Wetted Parts	316 Ti Stainless Steel
Operational	
Time Delay before Availability	2-15 seconds 8 seconds typical
Response time (DC)	1-15 seconds, 2 seconds typical
Maximum Temperature Change	4.2 °C/second

Flow Monitors

Drawings

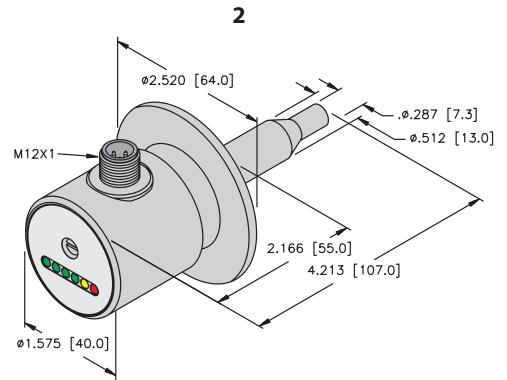
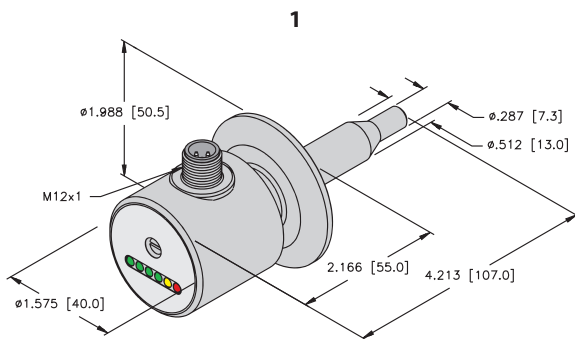

FLOW

Wiring Diagram

Diagram 1

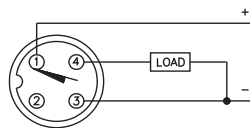

Mating Cordset:
RKV 4T - *

TURCK

Flow Monitors

Chemically Resistant Probe style Flow Monitors

- PTFE and PVDF Options
- Self Contained or Remote Versions



Part Number	Flow Detection Range Water (cm/s)	Flow Detection Range Oil (cm/s)	Fluid Connection	Output: Flow	Operating Voltage	Wetted Parts	Protection	Maximum Temperature Change	Probe Length (mm)	Wiring	Drawing #
FCS-G1/2DY-AP8X-H1141	1-70	2-100	G1/2"	PNP N.O.	24 VDC +/-10%	PVDF	IP67	0.05 °C/second	30	1	1
FCS-G1/2DY-AP8X	1-70	2-100	G1/2"	PNP N.O.	24 VDC +/-10%	PVDF	IP67	0.05 °C/second	30	2	2
FCS-G1/4T-NA	1-70	2-100	G1/4"	Remote Amplifier	Remote Amplifier	PTFE	IP68	1 °C/second	25	3	3
FCS-N1/2T-NA	1-70	2-100	1/2" NPT	Remote Amplifier	Remote Amplifier	PTFE	IP68	1 °C/second	42	3	4

Specifications:

Electrical	
Switching Current PNP outputs	400 mA
Current Consumption PNP outputs	70 mA
"NA" outputs require a "non-EX" remote amplifier	See page C49 for part numbers
Environmental	
Pressure Rating	72 PSI
Ambient Temperature	-25 to 70 °C
Media Temperature	-10 to 80 °C
Operational	
Time Delay before Availability	5-50 seconds 30 seconds typical
Response time	5-50 seconds, 30 seconds typical

Flow Monitors

FLOW

Drawings

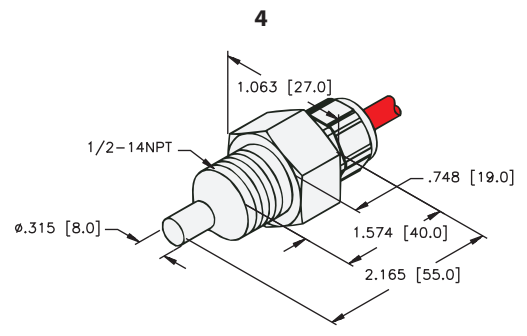
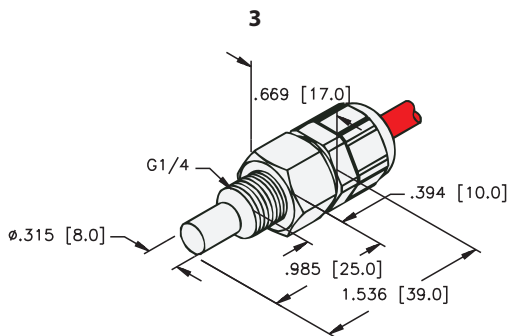
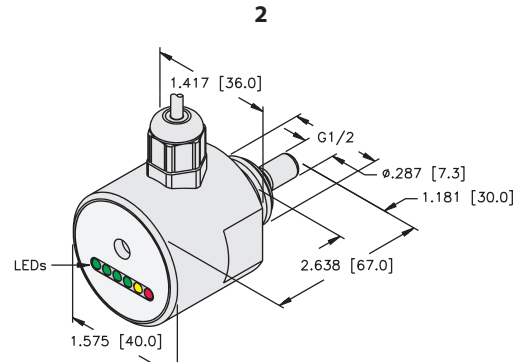
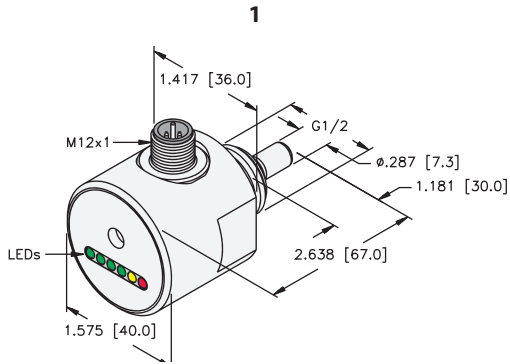

Wiring Diagrams

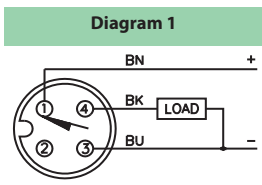

Mating Cordset:
RKK 4T-*

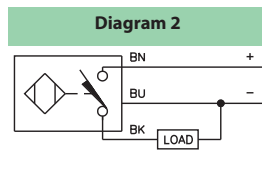

2M/PTFE Cable

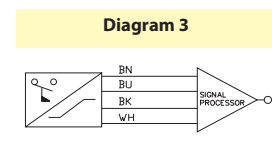

2M/PTFE Cable

TURCK

Flow Monitors

Remote Amplified Flow Sensor

- IP68 Options
- Extended Probe Lengths
- High Temperature Ranges
- High Pressure Ratings



Part Number	Flow Detection Range, Water (cm/s)	Flow Detection Range, Oil (cm/s)	Fluid Connection	Wetted Parts	Protection	Probe Length (mm)	Pressure Rating (psi)	Ambient Temperature (°C)	Media Temperature (°C)	Wiring	Drawing #
FCS-G1/2A4-NA-H1141	1-150	3-300	G 1/2"	316 TI SS	IP67	31	1450	-25 to 80	-25 to 80	2	5
FCS-G1/4A4-NA-H1141	1-150	3-300	G 1/4"	316 TI SS	IP67	24	1450	-25 to 80	-25 to 80	2	4
FCS-N1/2A4-NA-H1141	1-150	3-300	1/2" NPT	316 TI SS	IP67	42	1450	-25 to 80	-25 to 80	2	2
FCS-N1/2A4-NA-H1141/L060	1-150	3-300	1/2" NPT	316 TI SS	IP67	60	1450	-25 to 80	-25 to 80	2	2
FCS-N1/2A4-NA-H1141/L100	1-150	3-300	1/2" NPT	316 TI SS	IP67	100	1450	-25 to 80	-25 to 80	2	2
FCS-N3/4A4-NA-H1141	1-150	3-300	3/4" NPT	316 TI SS	IP67	47	1450	-25 to 80	-25 to 80	2	3
FCS-N1/2A4-NA	1-150	3-300	1/2" NPT	316 TI SS	IP67	42	1450	-25 to 80	-25 to 80	1	1
FCS-N1/2A4-NA/D100	1-150	3-300	1/2" NPT	316 TI SS	IP68	42	1450	-25 to 80	10 to 120	1	1
FCS-G1/2A4-NA/D100	1-150	3-300	G1/2"	316 TI SS	IP68	31	1450	-25 to 80	10 to 120	1	8
FCS-GL1/2A4-NA-H1141/D500	1-150	3-300	GL1/2"	316 TI SS	IP67	46	*	-25 to 80	-25 to 80	2	6

* = 1000 dynamic, 5600 static

Specifications:

Electrical	
Operating Voltage	Remote Amplifier
Output Characteristics	Remote Amplifier
"NA" outputs require a "non-EX" remote amplifier	See page C49 for part numbers
Operational	
Time Delay before Availability	2-15 seconds, 8 seconds typical
Response time	1-13 seconds, 2 seconds typical
Maximum Temperature Change	4.2 °C/second

Flow Monitors

Drawings

FLOW

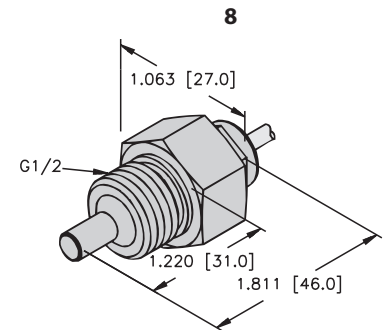
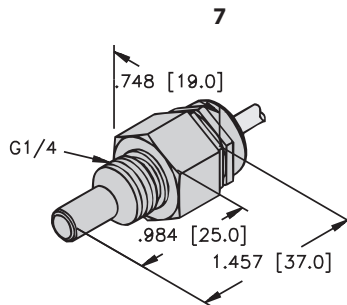
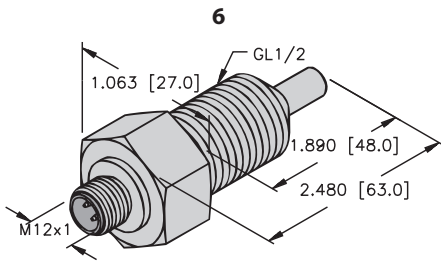
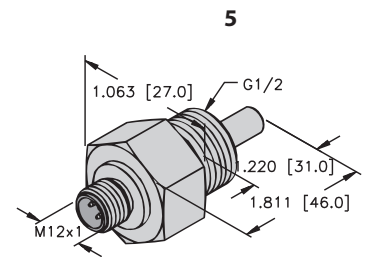
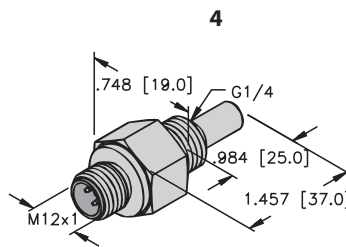
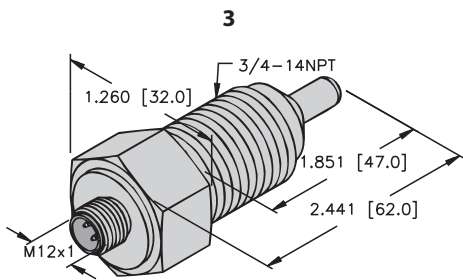
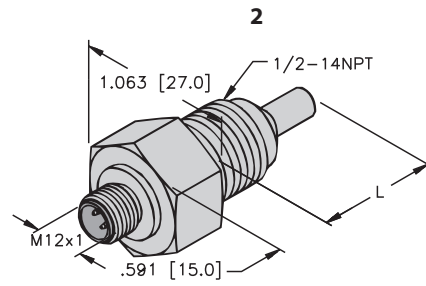
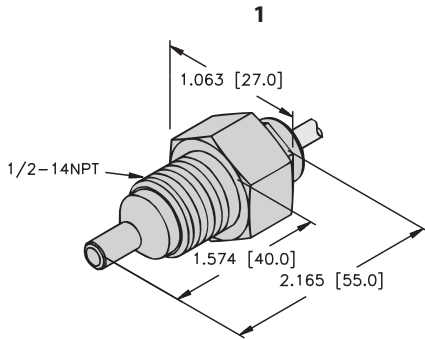

L = Probe length

Wiring Diagrams

Diagram 1

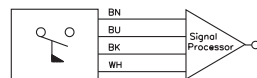

2M/PTFE Cable

Diagram 2

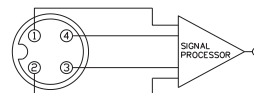

Mating Cordset:
RK 4.4T-*

TURCK

Flow Monitors

Chemically Resistant Flow Probes

- Fast Response Times
- Hastelloy or Titanium Options



Part Number	Water (cm/s)	Oil (cm/s)	Fluid Connection	Housing Material Wetted Parts	Protection	Probe Length (mm)	Pressure Rating (psi)	Ambient Temperature (°C)	Media Temperature (°C)	Wiring	Drawing
FCS-G1/2TN-NA-H1141	1-150	3-300	G 1/2"	Titanium	IP67	31	1450	-25 to 80	-25 to 80	1	1

Specifications:

Electrical	
Operating Voltage	Remote Amplifier
Output Characteristics	Remote Amplifier
"NA" outputs require a "non-EX" remote amplifier	See page C49 for part numbers
Operational	
Time Delay before Availability	2-15 seconds, 8 seconds typical
Response time (DC)	1-13 seconds, 2 seconds typical
Maximum Temperature Change	4.2 °C/second

Flow Monitors

Drawings

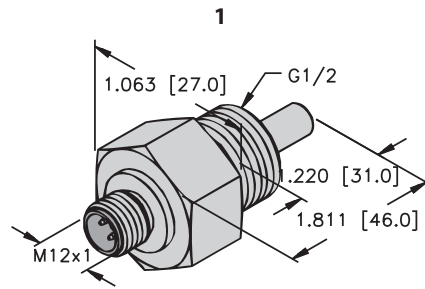

L = Probe length

FLOW

Wiring Diagrams

Diagram 1

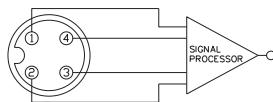

Mating Cordset:
RK 4.4T - *

TURCK

Flow Monitors

Intrinsically Safe Flow Probes

- Atex approved Flow Monitors
- Require an Amplifier



Part Number	Water (cm/s)	Oil (cm/s)	Fluid Connection	Housing Material Wetted Parts	Protection	Probe Length	Pressure Rating (psi)	Ambient Temperature (°C)	Media Temperature (°C)	Wiring	Drawing
FCS-N1/2A4-NAEX-H1141	1-150	3-300	1/2" NPT	316 TI SS	IP68	40	1450	-25 to 85	-25 to 85	2	1
FCS-N1/2A4-NAEX/D100	1-150	3-300	1/2" NPT	316 TI SS	IP68	40	1450	-25 to 80	10 to 120	1	2
FCS-N1/2A4-NAEX	1-150	3-200	1/2" NPT	316 TI SS	IP68	40	1450	-25 to 85	-25 to 85	1	2

* = 1000 dynamic, 5600 static

Specifications:

Electrical	
Operating Voltage	Remote Amplifier
Output Characteristics	Remote Amplifier
"NAEX" outputs require an "EX" remote amplifier	See page C49 for part numbers
Intrinsically Safe Parameters	
Approval	Ex 112G, Eex Ib IIC T6
Maximum Power	.69 W
Internal Inductance/Capacitance	Negligible
Temperature Class	T6: Tm 50 °C, T5: Tm 65 °C, T4: Tm 70 °C
Operational	
Time Delay before Availability	2-15 seconds, 8 seconds typical
Response time	1-13 seconds, 2 seconds typical
Maximum Temperature Change	4.2 °C/second

Flow Monitors

Drawings

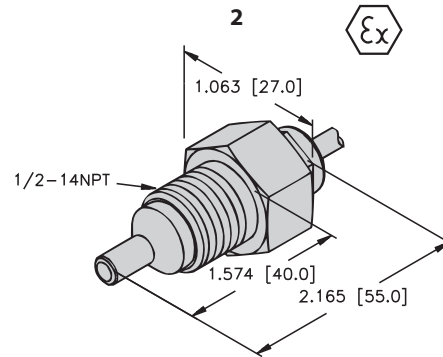
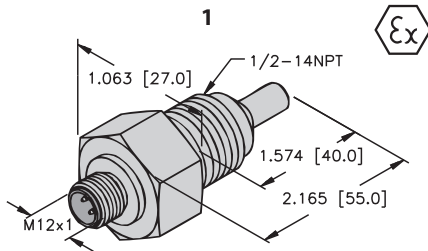

FLOW

Wiring Diagrams

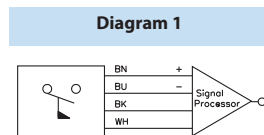

Cable: 2m/PTFE
2m/PUR

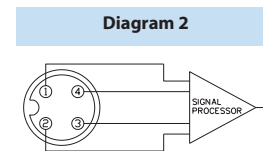

Mating cordset:
RK 4.41T - *

FCS AIR FLOW MONITOR

PRODUCT OVERVIEW

WHAT IS A FCS FLOW MONITOR?

A compact flow sensor for monitoring gaseous media. It is available in two versions: one that includes the sensor and signal processing unit in a single housing for local adjustment and display, and another where the sensors and signal processing unit are separated for remote monitoring purposes. In the case of the latter, the processor is housed in the control cabinet.

WHY CHOOSE A FCS FLOW MONITOR?

- Easy adjustment via potentiometer
- Transistor, relay or current output
- Insertion principle:
 - » Pressure resistance up to 30 bar
 - » Adjustable range between 0.5 m/s and 30 m/s
- Inline principle:
 - » No pressure loss
 - » Response time within seconds
 - » Adjustable range between 0.5 m/s and 40 m/s

WHERE CAN I USE A FCS FLOW MONITOR?

- Monitors that operate using the insertion principle are suited for most pipes.
- Monitors that operate using the inline principle are ideal for low flow rates and pipe diameters of up to 3/8".



Mounting Instructions

Proper Orientation For Airflow

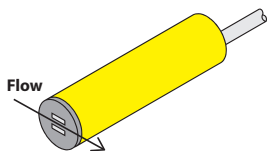

Proper Orientation For Dual Tips

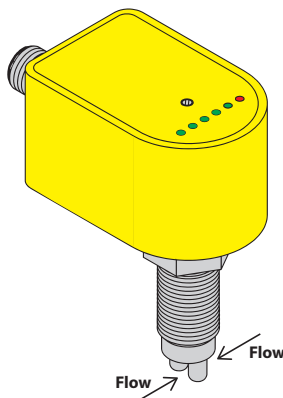

TURCK

Flow Monitors

Air Flow Monitors

- IP67
- Great for monitoring the flow of air and other inert gases



Part Number	Air (m/s) Flow Rate	Fluid Connection	Output: Flow	Pressure Rating (PSI)	Housing Material	Wiring	Drawing
FCS-M18-AP8X	.5-15	M18x1	PNP N.O.	43	Nickel Plated Brass	1	1
FCS-M18-AP8X/D041	.5-15	Mounting block G1/4 threads	PNP N.O.	43	Nickel Plated Brass	1	3
FCS-M18-AP8X/D087	.5-15	Mounting block 1/4" NPT threads	PNP N.O.	43	Nickel Plated Brass	1	3
FCS-K20-AP8X	.5-15	20mm Flange	PNP N.O.	14.5	PBT	1	2
FCS-M18-AN8X	.5-15	M18x1	NPN N.O.	43	Nickel Plated Brass	3	1
FCS-M18-LIX	.5-15	M18x1	4-20 mA Non-Linear Analog	43	Nickel Plated Brass	2	1
FCS-M18-LIX/D067	.5-45	M18x1	4-20 mA Non-Linear Analog	43	Nickel Plated Brass	2	1
FCS-M18-LIX/D041	.5-15	M18x1	4-20 mA Non-Linear Analog	43	Nickel Plated Brass	2	3
FCS-M18-LIX/D087	.5-15	M18x1	4-20 mA Non-Linear Analog	43	Nickel Plated Brass	2	3
FCS-K20-LIX	.5-15	20mm Flange	4-20 mA Non-Linear Analog	14.5	PBT	2	2

Specifications:

Electrical	
Operating Voltage	24 VDC +/-20%
Switching Current PNP outputs	200 mA
Analog Load 4-20 mA outputs	500
Current Consumption	70 mA
Environmental	
Protection	IP67
Ambient Temperature	-20 to 70 °C
Media Temperature	-20 to 70 °C
Operational	
Time Delay before Availability	20-40 seconds, 30 seconds typical
Response time	1-5 seconds, 2 seconds typical
Maximum Temperature Change	3.3 °C/second

Flow Monitors

Drawings

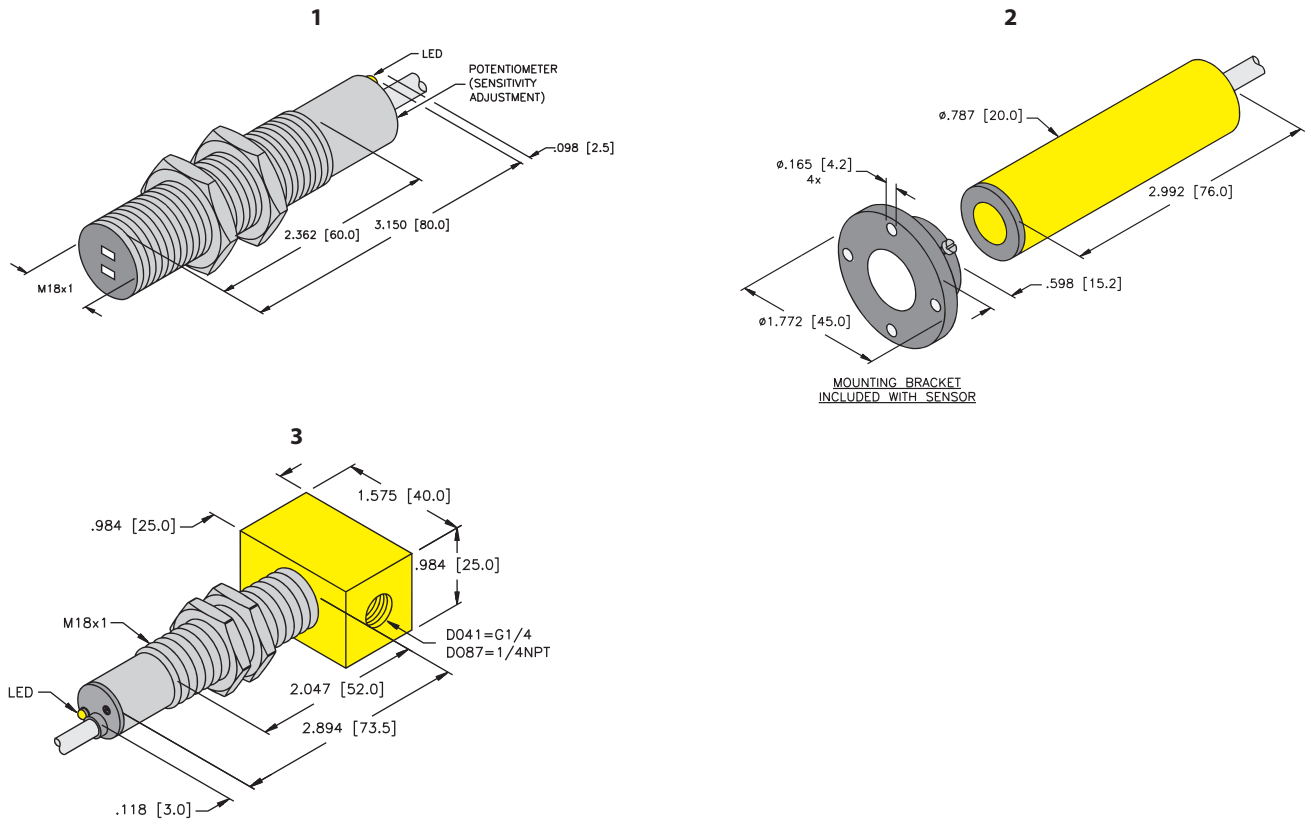

FLOW

Wiring Diagrams

Diagram 1

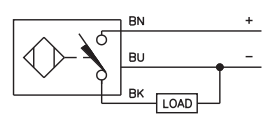

2M/PVC Cable

Diagram 2

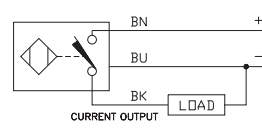

2M/PVC Cable

Diagram 3

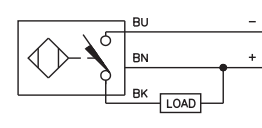

2M/PVC Cable

TURCK

Flow Monitors

Air Flow Monitors

- IP65
- LED visualization of flow rate
- Great for monitoring the flow of air and other inert gases



Part Number	Air (m/s) Flow Rate	Fluid Connection	Output: Flow	Wiring	Drawing
FCS-GL1/2A2P-LIX-H1141/A	.5-30	GL 1/2"	4-20 mA Non-Linear Analog	2	1
FCS-GL1/2A2P-AP8X-H1141/A	.5-30	GL 1/2"	PNP N.O.	1	1

Specifications:

Electrical	
Operating Voltage	24 VDC +/-15%
Switching Current PNP outputs	200 mA
Analog Load 4-20 mA outputs	500
Current Consumption	80 mA
Environmental	
Protection	IP67
Pressure Rating	435 PSI
Ambient Temperature	-20 to 70 °C
Media Temperature	-20 to 70 °C
Materials	
Probe	AISI 303
Housing	PBT
Operational	
Time Delay before Availability	20-40 seconds, 30 seconds typical
Response time	1-5 seconds, 2 seconds typical
Maximum Temperature Change	3.3 °C/second

Flow Monitors

Drawing

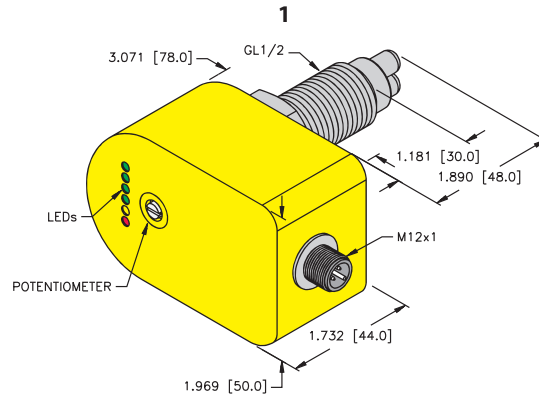

FLOW

Wiring Diagrams

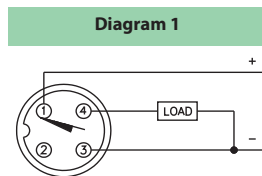

Mating cordset:
RK 4T-*

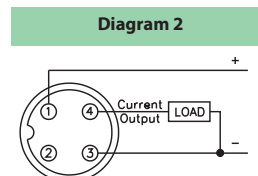

Mating cordset:
RK 4T-*/S618

TURCK

Flow Monitors

Intrinsically Safe Air Flow Monitors

- IP67
- Remote Probes
- ATEX Approval Intrinsically Safe

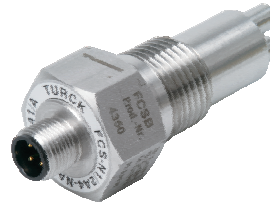

Part Number	Air (m/s)	Fluid Connection	Probe Length (mm)	Wiring	Drawing
FCS-GL1/2A4-NAEX0/A	2-20	GL 1/2"	48	1	1

Specifications:

Electrical	
Operating Voltage	Remote Amplifier see page C49
Output Characteristic	Remote Amplifier see page C49
Environmental	
Protection	IP67
Pressure Rating	1450 PSI
Ambient Temperature	-25 to 60 °C
Media Temperature	-25 to 80 °C
Intrinsically Safe Parameters	
Approval	Ex 11 2G, Eex Ib IIC T6
Maximum Power	.69 W
Internal Inductance/Capacitance	Negligible
Temperature Class	T6: Tm 50 °C, T5: Tm 65 °C, T4: Tm 70 °C
Materials	
Housing	316Ti
Operational	
Time Delay before Availability	2-15 seconds 8 seconds typical
Response time (DC)	1-13 seconds, 2 seconds typical
Maximum Temperature Change	10° C/minute

Flow Monitors

Drawings

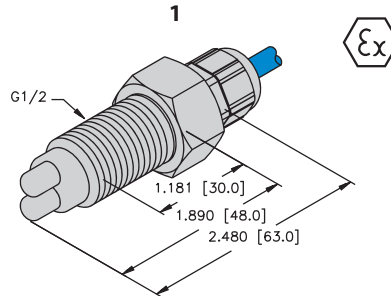

FLOW

Wiring Diagrams

Diagram 1

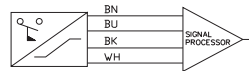

2M/PUR Cable

TURCK

Interface Technology

Remote Amplifiers

- Signal Processors For Remote Probes
- IP20

Part Number	Output	Intrinsically Safe Ex II(1) GD [EEx ia] IIC	Wire-break detection	Dual Potentiometer for adjustment	Off Delay 0-25s adjustable	Temperature adjustable 20-100 °C	Short-Circuit/ Reverse Polarity Protection	Operating Voltage	Current Consumption (mA)	Switching Current	Mounting	Wiring	Drawing
MS96-11EX0-R/115VAC	Relay N.O./N.C.						99-121 VAC	75	4 A at 250 VAC / 0.8 A at 60 VDC	DIN 50022	1	1	
MS96-11EX0-R/24VDC	Relay N.O./N.C.						21-28 VDC	125	4 A at 250 VAC / 0.8 A at 60 VDC	DIN 50022	1	1	
MS96-12R/230VAC	Dual Relay N.O./N.C.						184-265 VAC	35	2 A at 250 VAC / 2 A at 60 VDC	DIN 50022	2	2	
MS96-12R/115VAC	Dual Relay N.O./N.C.						104-126 VAC	90	2 A at 250 VAC / 2 A at 60 VDC	DIN 50022	2	2	
MS96-12R/024VDC	Dual Relay N.O./N.C.						22-26 VDC	120	2 A at 250 VAC / 2 A at 60 VDC	DIN 50022	2	2	
MK 96-VP01	PNP N.O./N.C.						20-28 VDC	65	400 mA	DIN 50022 or 50035	4	3	
MK 96-LI01	4-20 mA Non-Linear analog						20-28 VDC	100	Analog Load: 500	DIN 50022 or 50035	5	3	
MK 96-11-R/024VDC	Relay N.O.						20-28 VDC	70	1 A at 230 VAC / 2 A at 60 VDC	DIN 50022 or 50035	3	3	

Flow Monitors

Drawings

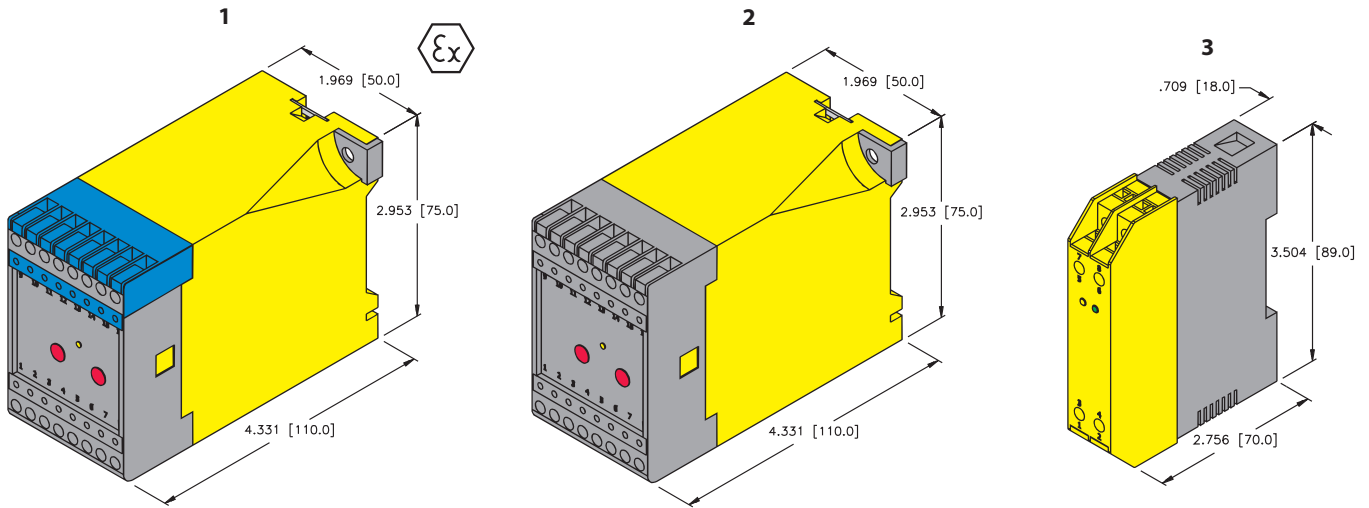

Wiring Diagrams

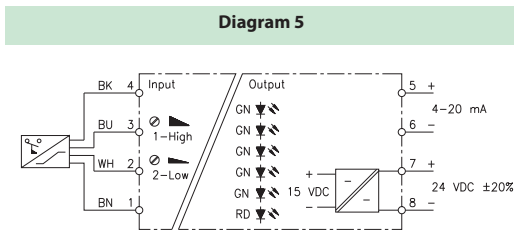
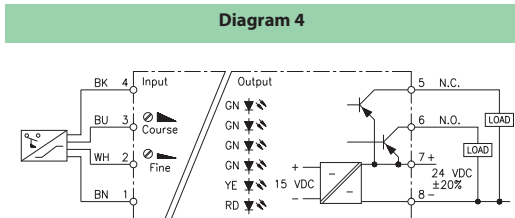
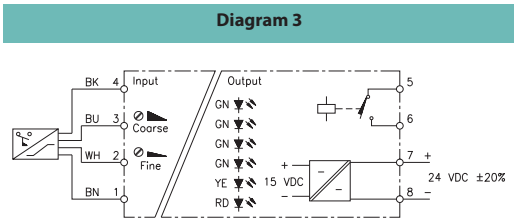
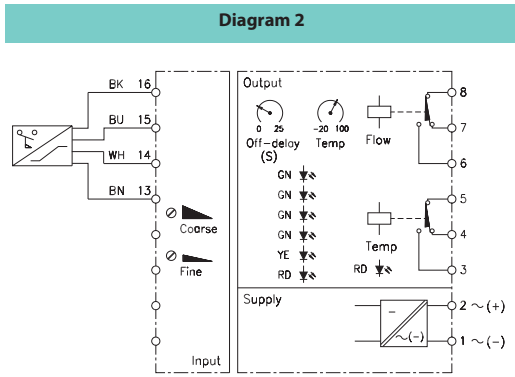
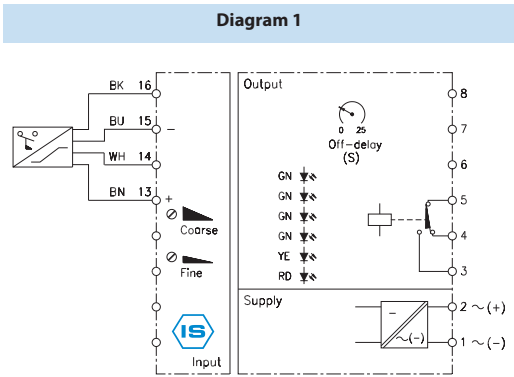

TURCK Flow Monitors

Liquid Flow Conversion Chart (Water)

Flow velocity to flow volume for schedule 40 pipes of various sizes.

Flow Conversions:

$$\text{GPM} = .0803 \times \text{ID}^2 \times \text{FS}$$

GPM = Gallons per minute

ID = Inner pipe diameter in inches

FS = Flow speed in cm/s (centimeters/second)

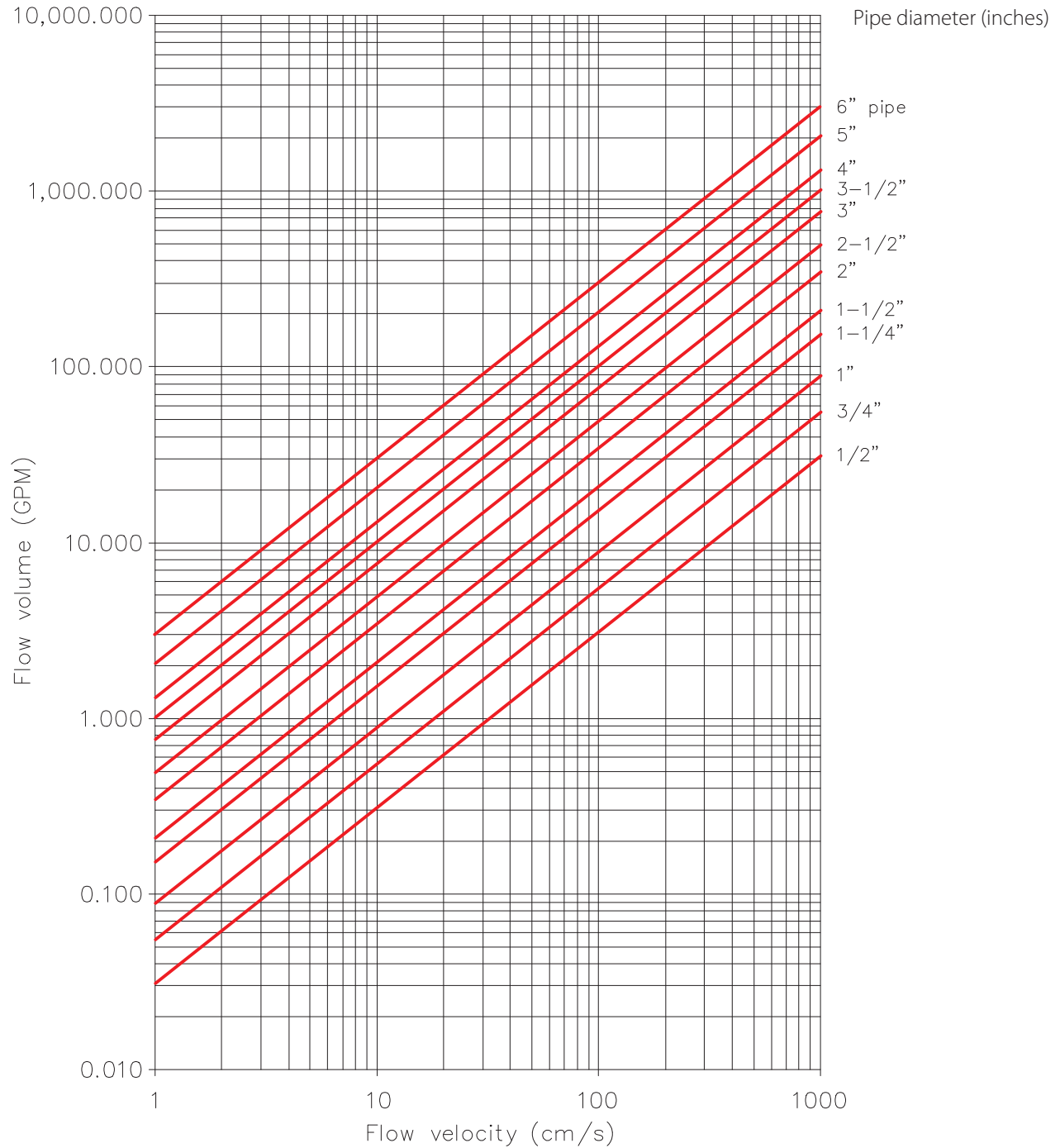

Flow Monitors

Gas Flow Conversion Chart (Air)

Flow velocity to flow volume for schedule 40 pipes of various sizes.

Flow Conversions:

$$\text{SCFM} = 1.0737 \times \text{ID}^2 \times \text{FSM}$$

SCFM = Standard cubic feet per minute

ID = Inner pipe diameter in inches

FSM = Flow speed in m/s (meters/second)

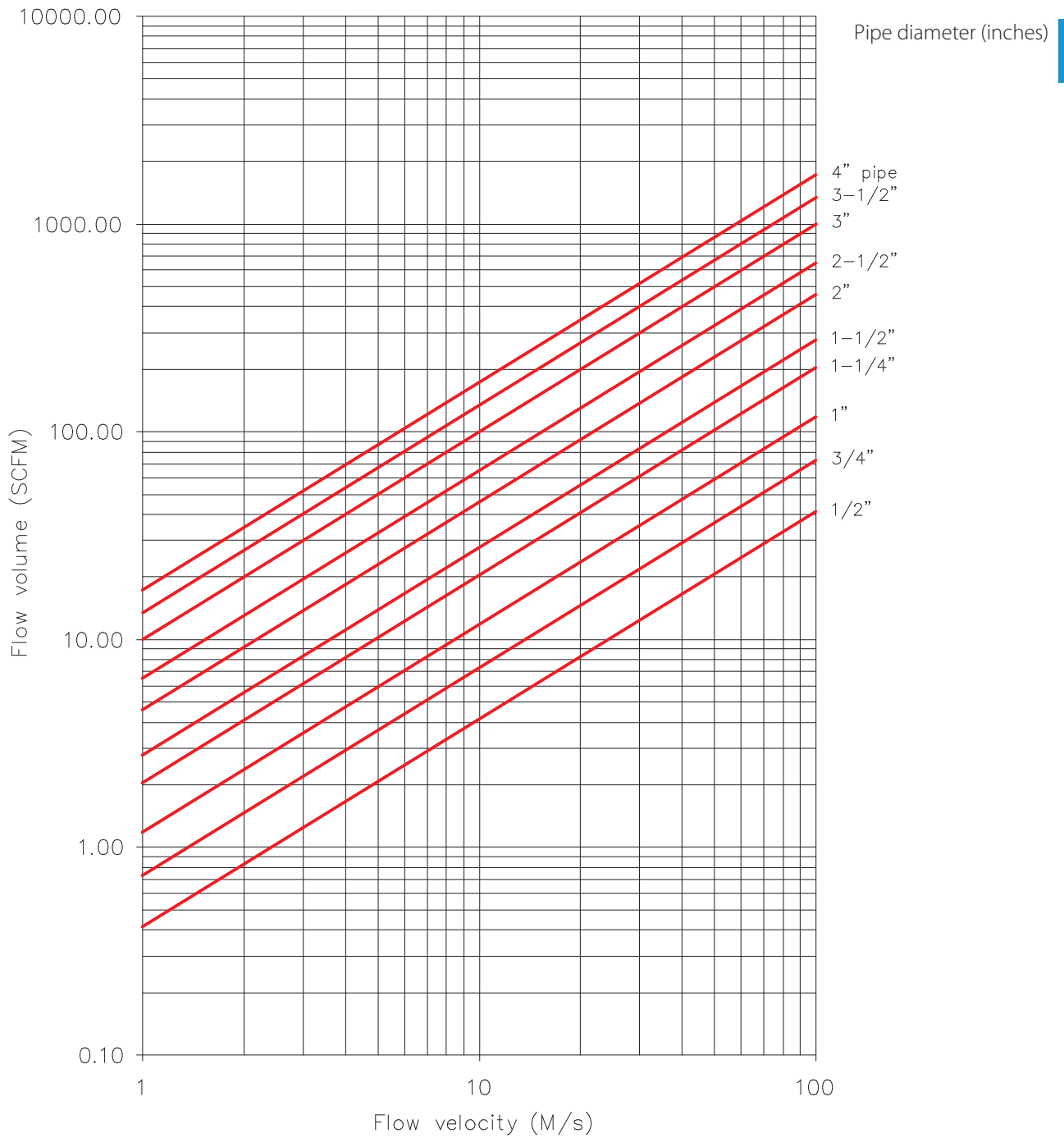

FLOW

TEMPERATURE SENSORS SELECTION GUIDE

Housing	Style	Features	Applications	Page
	TS Series The TS400/500 temperature sensors are robust stainless steel sensors for Pt-100 RTDs.	<ul style="list-style-type: none"> ■ High accuracy ■ Rotatable housing ■ IP67 ■ -50 to 500°C (-58 to 932°F) ■ PNP/NPN programmable ■ Wide range of configurations with TP probes 	<ul style="list-style-type: none"> ■ Food and beverage ■ Hydraulics ■ Cooling lines ■ Plastics ■ Pharmaceutical ■ Metal forming ■ Oils 	D3
	TT Series Available with remote or integral probes, this is an economical temperature transmitter for OEM applications.	<ul style="list-style-type: none"> ■ 4-20 mA Analog transmitter ■ -200 to 850°C ■ IP67 ■ Works with TP probes 	<ul style="list-style-type: none"> ■ OEM ■ Food and beverage ■ Hydraulics ■ Cooling lines ■ Plastics 	D7
	TTM Series Miniature temperature transmitters come pre-scaled so there is no need for adjustment.	<ul style="list-style-type: none"> ■ 4 standard ranges: -5 to 50°C 0 to 100°C -50 to 150°C 0 to 150°C ■ 4-20 mA output 	<ul style="list-style-type: none"> ■ OEM ■ Hydraulics ■ Food and beverage ■ Oils 	D8
	TP Temperature Probes TP probes are platinum four-wire resistance temperature detectors (RTD).	<ul style="list-style-type: none"> ■ PT 100 RTDs ■ 4-wire ■ Variety of styles and lengths 	<ul style="list-style-type: none"> ■ TS series ■ TT series ■ IM 34 with cordset 	D13
	Process Connections Compression fittings or thermowells are necessary for probe installation.	<ul style="list-style-type: none"> ■ Stainless Steel ■ NPT threads ■ Tri-clamp fitting 	<ul style="list-style-type: none"> ■ TP series probes 	D17
	IM34 Temperature Converters The IM34 will convert a 2, 3 or 4-wire RTD, thermocouple or mV signal to an analog 4-20 mA signal in a non-hazardous area.	<ul style="list-style-type: none"> ■ Input: RTD or thermocouples ■ Output: 4-20 mA ■ Display model ■ Relay and transistor outputs ■ PACTware compatible models 	<ul style="list-style-type: none"> ■ Hazardous areas 	D21

TEMPERATURE SENSORS

PRODUCT OVERVIEW

WHAT ARE TURCK TEMPERATURE INSTRUMENTS?

TURCK's temperature instruments utilize platinum resistance temperature detectors (RTDs), commonly referred to as a Pt-100 technology. Pt-100's contain a platinum wire that is wrapped around a core or patterned as a thin film on a substrate so that it experiences minimal differential expansion or other strains. As the temperature changes, the controller measures the change in the electrical resistance of the platinum wire. The resistance experienced by the sensor is proportional to the temperature changes being experienced by the media being sensed. Specifically, the hotter the wire becomes, the higher the value of electrical resistance. They require a small power source in order to measure resistance.

WHY CHOOSE TURCK TEMPERATURE INSTRUMENTS?

- Pt-100 technology is known to be highly precise, repeatable, and provide extremely short response times.
- Pt-100 RTDs have a nominal resistance of 100 ohms at 0°C with an accuracy of 0.4°C at 50°C. The sensor's operating range varies from -50 to 500°C (-58 to 932°F).
- Miniature transmitters that provide an analog signal directly from a M12 *eurofast*® connector.
- Robust internal and external design features; some models rated for IP67 protection.
- Easy to program and maintain.
- Remote or direct mounting; variety of probe lengths up to 2 meters; thermowells, compression fittings,



WHERE CAN I USE TURCK TEMPERATURE INSTRUMENTS?

- Food and beverage
- Hydraulic temperature
- Cooling lines
- Pharmaceutical
- Metal forming

TEMPERATURE SENSORS – TS400 & TS500

PRODUCT OVERVIEW

WHAT ARE THE TS400 AND TS500 SENSORS?

Robust Pt-100 RTD sensors designed to handle harsh manufacturing environments.

WHY CHOOSE TS400 AND TS500 SENSORS?

- Simple push-button programming includes a recessed button that stores selected values and helps prevent inadvertently changing parameters.
 - Large LED display that can be inverted electronically; the TS500 version can be rotated 320 degrees.
 - Versions with multiple outputs available; displays output in °C, °F, K and ohms.
 - Does not require regular maintenance calibration.
 - High immunity to electromagnetic interference.
- Robust stainless steel housing that provides an IP67 environmental protection rating.
 - Remote or direct mountable; compatible with 4-wire probes
 - Housing design permits sensors to be mounted directly next to each other or in restrictive places.
 - 4-pin M12 *eurofast*® connection promotes easy integration in existing applications.

WHERE CAN I USE TS400 AND TS500 SENSORS?

- May be implemented in nearly all factory or process automation applications.
- Food and beverage
- Cooling lines
- Bearing temperature

How to Order TS400 and TS500 Sensors and Accessories

1. Determine your desired output and select the TS model that meets your needs.
2. Select the appropriate probe for your application.
 - a) Questions? Call applications support at 1-800-554-7769.
3. Choose remote or direct mounting.
 - a) For direct mounting use the TP-206, order the stabilizer (STA-6) for applications with vibration.
 - b) For remote mounting, order a mating cordset (RK 4.4T-*/-RS 4.4T).
4. Select a process connection.
 - a) For thermowells, order one length (50 mm) shorter than the length of probe you selected in step 2.
 - b) If no thermowell is selected, a compression fitting is needed for mounting the probe.

* Length in meters.



Direct Mounting



Remote Mounting

Complete Installation Guide

Remote Mounting Sensor

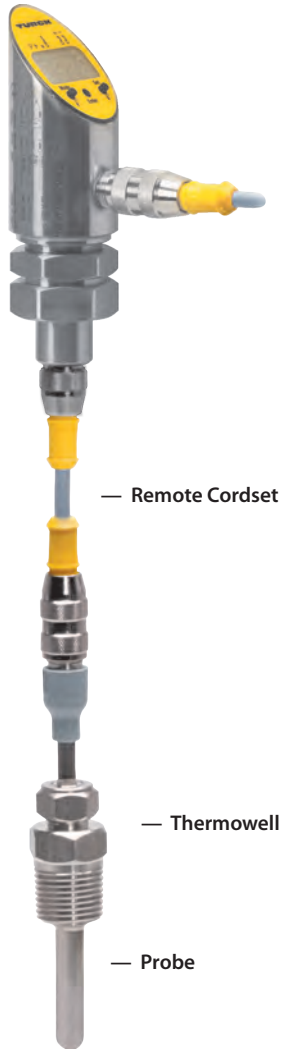

— Remote Cordset

— Thermowell

— Probe

Direct Mounting Sensor



— Compression fitting

— Probe

Accessories



Remote Cordset
RK 4.4T-* - RS 4.4T

Probe Options



TP-104A..



TP-203A.. or
206A..



TP-306A..

Process Connection Options



Compression Fitting
(CF)



Thermowell
THW...TRI



Thermowell
THW...N

TS400/TS500 Temperature Sensor Part Number Key

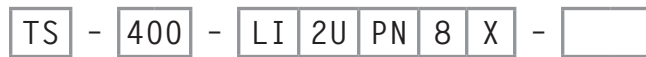

Style

TS = temperature sensors

Housing

400 = adjustable, with display, non-rotatable
500 = adjustable, with display, rotatable

Analog output

LI = current analog output
LU = voltage analog output

Switching output

2U = 2 x programmable N.O./N.C. mode
U = 1 x programmable N.O./N.C. mode

Connection

H1141 = 4-pin M12 *euromat*® connector

With LED display

Operational voltage

8 = 15-30 VDC (switching outputs)
8 = 18-30 VDC (switching and analog outputs)

Output logic

PN = PNP/NPN configurable transistor switching output

TURCK

Temperature Instrumentation

TS 400/500 Programmable Temperature

- -50 to +500 °C Range
- IP67
- Digital Display



Part Number	Measuring Range (°C)	Operating Voltage	Output	Wiring	Drawing
TS-400-LI2UPN8X-H1141	-50-500	18-30 VDC	Analog Current & 1 PNP/NPN switch point	3	1
TS-400-LUUPN8X-H1141	-50-500	18-30 VDC	Analog Voltage & 1 PNP/NPN switch point	2	1
TS-400-2UPN8X-H1141	-50-500	15-30 VDC	2 PNP/NPN switch points	1	1
TS-500-LI2UPN8X-H1141	-50-500	18-30 VDC	Analog Current & 1 PNP/NPN switch point	3	2
TS-500-LUUPN8X-H1141	-50-500	18-30 VDC	Analog Voltage & 1 PNP/NPN switch point	2	2
TS-500-2UPN8X-H1141	-50-500	15-30 VDC	2 PNP/NPN switch points	1	2

Specifications:	
Electrical	
Operating Voltage	15-30 VDC (switching output) 18-30 VDC (switching and analog output)
No-load current	50 mA
SELV, PELV	According to EN 50178
Short-circuit Protection	Yes
Reverse Polarity Protection	Yes
Insulation Class	III
Switching Output	
Switching Frequency	180 Hz
Output function	2 x PNP or NPN, N.C. /N.O. programmable
Voltage Drop	2 V
Rated Operational Current	0.2 A
Switching Point Distance	0.2 °C
Switch Point Range	-49.8 to +500 °C (-58 to +932 °F)
Reset Point Range	-50 to +499.8 °C (-58 to +932 °F)
Analog Current Output	
Current Output	4-20 mA, 0-20 mA, 20-4 mA, 20-0 mA programmable
Response Time	<100 ms
Load	0.5 k
Analog Voltage Output	
Voltage Output	0-10 V
Response Time	<100 ms
Load	2 k
Temperature Sensor Accuracy	
Switching Point Accuracy	≥ 0.2 °C
Repetition Accuracy	≥ 0.1 °C
Analog Output Accuracy (Lin. + Hys. + Rep.)	≥ 0.2 °C
Temperature Sensor Housing	
Housing Material	Stainless Steel/Plastic, V2A (1.4305)
Electrical Connection	Connectors, M12x1
Sensor Connection	Connectors, M12x1
Coupling Nut Size	SW 30 (max. 35Nm)

Specifications:	
Display:	
Temperature Display	4-digit 7-segment display can be rotated by 180° and switched off
Switch State Display	2 x LED yellow
Measured Value/Programming	Switch/release points; hysteresis/window mode; N.O./N.C.; unit of display; peak value memory
Display of Temperature Unit	4 x LED green (°C, °F, K,)
EMC:	
EN 61000-4-2	ESD 4 kV CD / 8 kV AD
EN 61000-4-3	HF radiated: 15 V/m2
EN 61000-4-4	Burst 2 kV
EN 61000-4-5	Surge 1 kV, 42
EN 61000-4-6	HF conducted: 10 V
Ambient Conditions:	
Medium Temperature	Directly connected: -50 to +150°C; Remotely connected: -50 to +150°C
Ambient Temperature	-40° to +80°C (-40° to +176°F)
Storage Temperature	-40° to +80°C (-40° to +176°F)
Degree of Protection	IP67
Vibration Resistance	20 g (10-2000 Hz) according to IEC 68-2-6
Shock Resistance	50 x g (11 ms) according to IEC 68-2-27

Temperature Instrumentation

Drawings

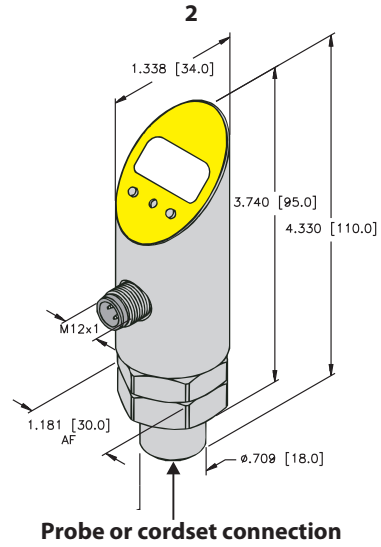
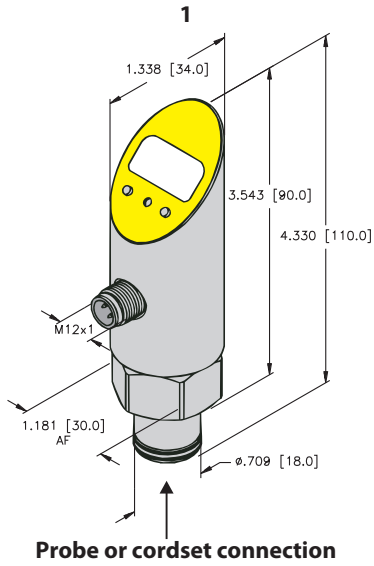

TEMPERATURE

Wiring Diagrams

Diagram 1

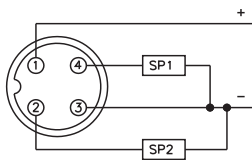

Mating cordset:
RK 4.4T-*

Diagram 2

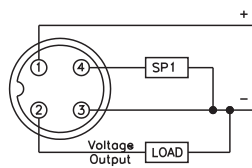

Mating cordset:
RK 4.4T-*/S618

Diagram 3

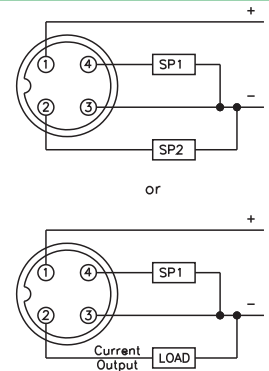

Mating cordset:
RK 4.4T-*/S618

TEMPERATURE TRANSMITTERS

PRODUCT OVERVIEW

WHAT ARE TURCK'S TEMPERATURE TRANSMITTERS?

TURCK temperature transmitters are platinum resistance temperature detectors (RTD's), otherwise known as Pt-100's.

WHY CHOOSE TURCK'S TEMPERATURE TRANSMITTERS?

- The transmitter's operating range is set at 0-150°C, but other ranges can be achieved by contacting the factory.
- Models are available with or without integral probes, and are compatible with TURCK's TP-Series of probes.
- Rugged 316 stainless steel housing provides an IP67 protection rating.

WHERE CAN I USE TURCK'S TEMPERATURE TRANSMITTERS?

- OEM applications
- Food and beverage
- Hydraulics
- Oils



Temperature Transmitter for PT-100 RTDs Part Number Key

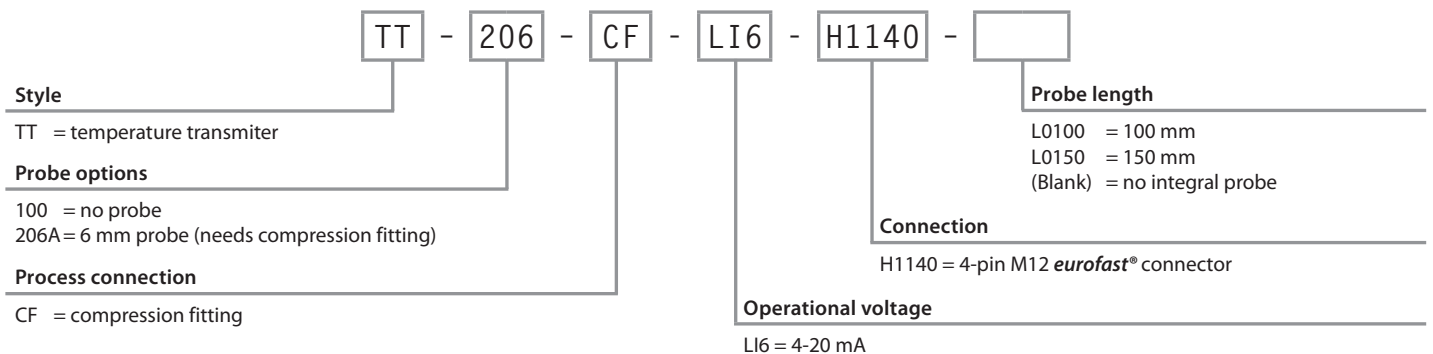

MINIATURE TEMPERATURE TRANSMITTERS

PRODUCT OVERVIEW

WHAT ARE MINIATURE TEMPERATURE TRANSMITTERS?

Miniature temperature transmitters that include an integrated M12 connection. The transmitters utilize the same Pt-100 technology as TURCK's other temperature products with a pre-scaled 4-20 mA output.

WHY CHOOSE TURCK'S TEMPERATURE TRANSMITTERS?

The probes have a convenient M12 *eurofast*® connection and do not require special cables.

- Available in four temperature ranges: 0-100°C, -50-50°C, 0 to 150 degrees°C, and -50-150°C.

WHERE CAN I USE TURCK'S TEMPERATURE TRANSMITTERS?

- OEM applications
- Hydraulics
- Cooling lines
- Lubrication



Miniature Temperature Transmitter Part Number Key

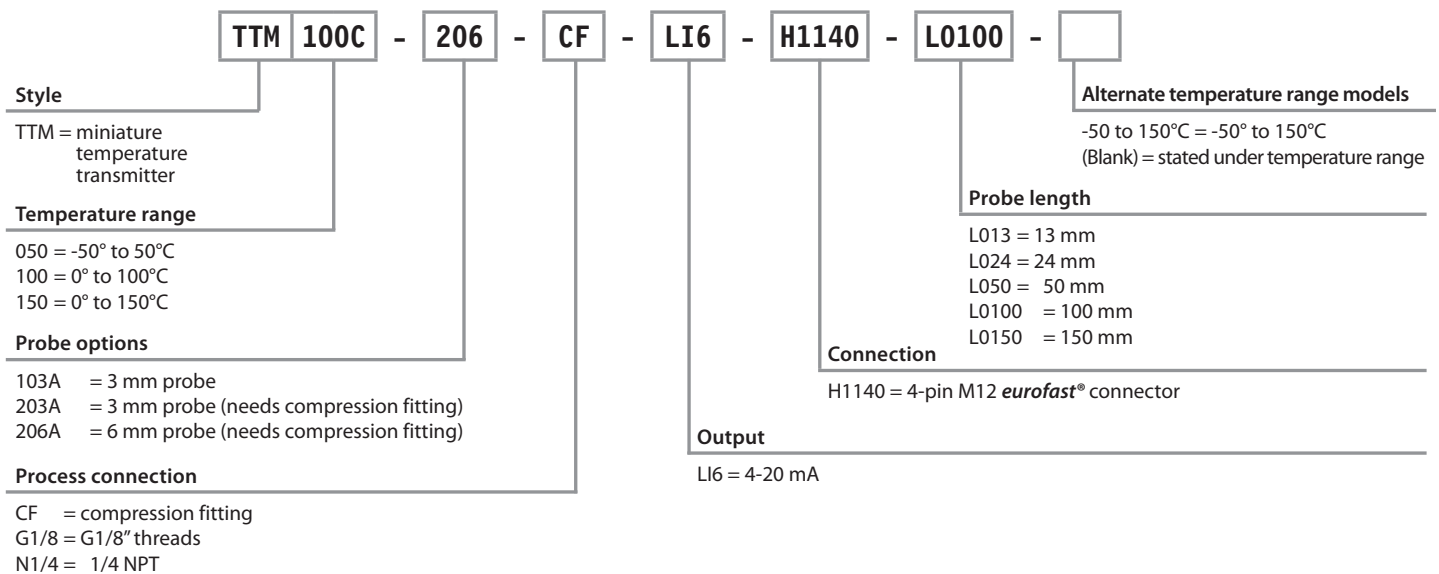

TURCK

Temperature Instrumentation

Temperature Transmitters

- Available with Integral Probe
- Other Ranges can be Factory Set



Part Number	Range	Analog Load	Probe Length (mm)	Wiring	Drawing
TT-100-LI6-H1140	0° to 150°C (32° to 302°F) Factory Set*	1.2 k	N/A	1 & 2	1
TT-206A-CF-LI6-H1140-L0100	0° to 150°C (32° to 302°F) Factory Set*	1.2 k	100	1	2
TT-206A-CF-LI6-H1140-L0150	0° to 150°C (32° to 302°F) Factory Set*	1.2 k	150	1	2

* Other ranges can be obtained by contacting the factory.
/S1792 = 0-150°F

Specifications:

Electrical	
Range	-200 to 850 C
Supply Voltage	8-35 VDC
Signal Range	4-20 mA
Update Time	135 ms
Max Load Resistance	(Vsupply-8V)/.023
Environmental	
Ambient Temperature	-40° to +85°C (-40° to +185°F)
Protection	IP67
Accuracy	
Accuracy	±.3°C/°C or ≥.1% of span
Temperature Effects	≥.01°C/°C or ≥.01% of span
EMC Effects	≥0.5% of span
Housing	
Housing Material	Stainless Steel AISI 316
Electrical Connection	M12

Temperature Instrumentation

Drawings

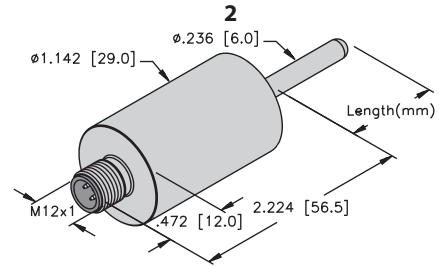
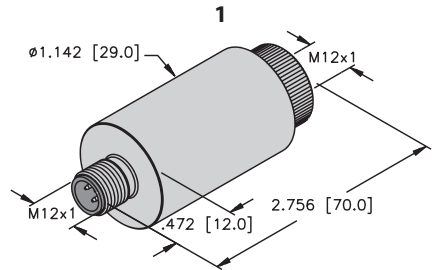

TEMPERATURE

Wiring Diagram

Diagram 1

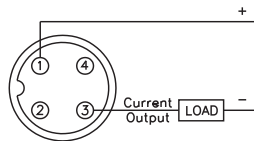

Mating cordset:
RK 4T-*/S618

Diagram 2 - Female M12

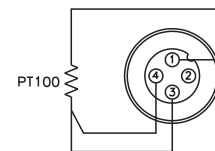

Mating cordset:
RK 4T-**-RS 4T/S618

TURCK

Temperature Instrumentation

TTM - Miniature Temperature Transmitters

- 4-20 mA output
- Two wire loop power
- IP67

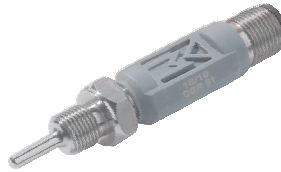

Part Number	Temperature Range (°C)	Process Connection	Probe Length (mm)	Drawing
TTM100C-203A-CF-LI6-H1140-L100	0-100	Compression Fitting	100	1
TTM150C-203A-CF-LI6-H1140-L100	0-150	Compression Fitting	100	1
TTM150C-203A-CF-LI6-H1140-L100-50...150°C	-50-150	Compression Fitting	100	1
TTM050C-203A-CF-LI6-H1140-L100-50...50°C	-50-50	Compression Fitting	100	1
TTM100C-206A-CF-LI6-H1140-L050	0-100	Compression Fitting	50	2
TTM100C-206A-CF-LI6-H1140-L100	0-100	Compression Fitting	100	2
TTM150C-206A-CF-LI6-H1140-L100	0-150	Compression Fitting	100	2
TTM150C-206A-CF-LI6-H1140-L100-50...150°C	-50-150	Compression Fitting	100	2
TTM050C-206A-CF-LI6-H1140-L100-50...50°C	-50-50	Compression Fitting	100	2
TTM100C-203A-CF-LI6-H1140-L150	0-100	Compression Fitting	150	1
TTM150C-203A-CF-LI6-H1140-L150	0-150	Compression Fitting	150	1
TTM150C-203A-CF-LI6-H1140-L150-50...150°C	-50-150	Compression Fitting	150	1
TTM050C-203A-CF-LI6-H1140-L150-50...50°C	-50-50	Compression Fitting	150	1
TTM100C-206A-CF-LI6-H1140-L150	0-100	Compression Fitting	150	2
TTM150C-206A-CF-LI6-H1140-L150	0-150	Compression Fitting	150	2
TTM150C-206A-CF-LI6-H1140-L150-50...150°C	-50-150	Compression Fitting	150	2
TTM050C-206A-CF-LI6-H1140-L150-50...50°C	-50-50	Compression Fitting	150	2
TTM100C-103A-G1/8-LI6-H1140-L013	0-100	G 1/8"	13	3
TTM100C-103A-N1/4-LI6-H1140-L013	0-100	1/4 NPT	13	4
TTM050C-103A-G1/8-LI6-H1140-L013-50...50°C	-50-50	G 1/8"	13	3
TTM100C-103A-G1/8-LI6-H1140-L024	0-100	G 1/8"	24	3
TTM100C-103A-N1/4-LI6-H1140-L024	0-100	1/4 NPT	24	4
TTM050C-103A-G1/8-LI6-H1140-L024-50...50°C	-50-50	G 1/8"	24	3

Temperature Instrumentation

TEMPERATURE

Specifications

Electrical	
Operating Voltage	10-24 VDC
No-load current	20 mA
Current Output	4-20 mA
Short-circuit Protection	Yes
Reverse Polarity Protection	Yes
Environmental	
Accuracy (Lin. + Hys. + Rep.)	$\leq 0.1\%$ of final value BFSL
Accuracy	Class A
Ambient Temperature	-40 to +80 C
Storage Temperature	-40 to +80 C
Measuring Element	Pt-1000 Platinum measuring element DIN EN 60751
Mechanical	
Sensor Material	Stainless Steel, AISI 316L
Pressure Resistance	100 bar
Electrical Connection	Connectors, M12x1

Drawings

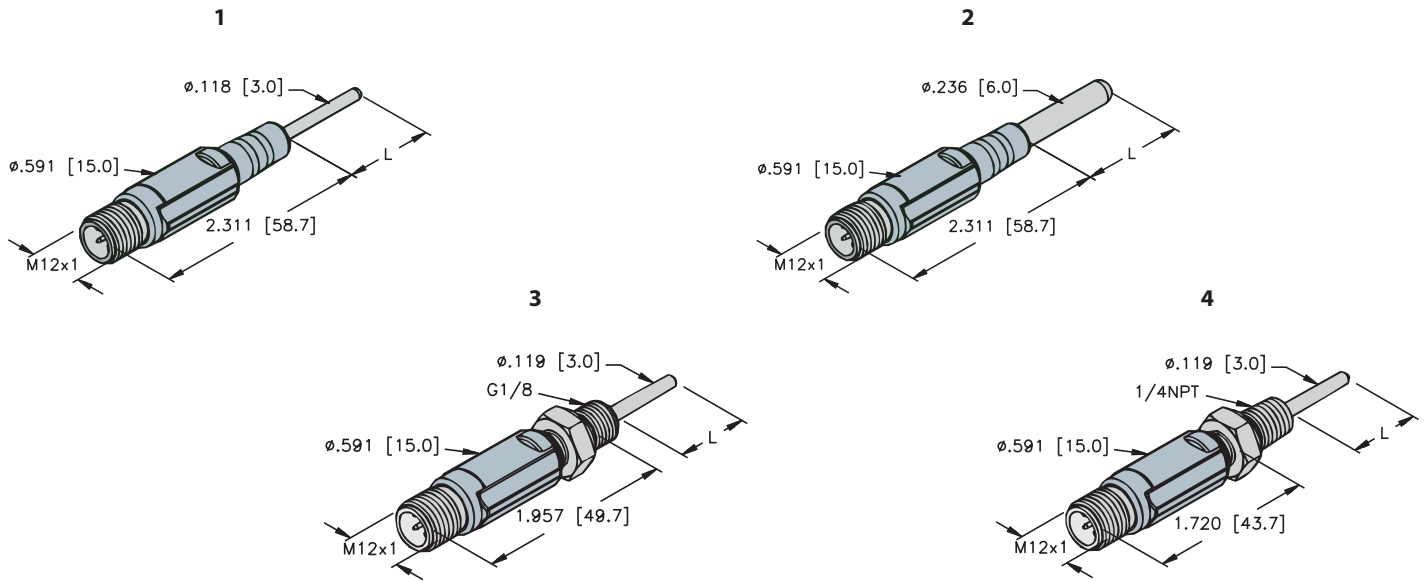

L = Probe length, see table on previous page.

Wiring Diagram

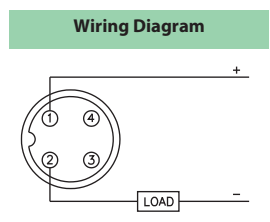

Mating cordset:
RK 4.4T-*/S618

TURCK

Temperature Instrumentation

Temperature Probes Part Number Key

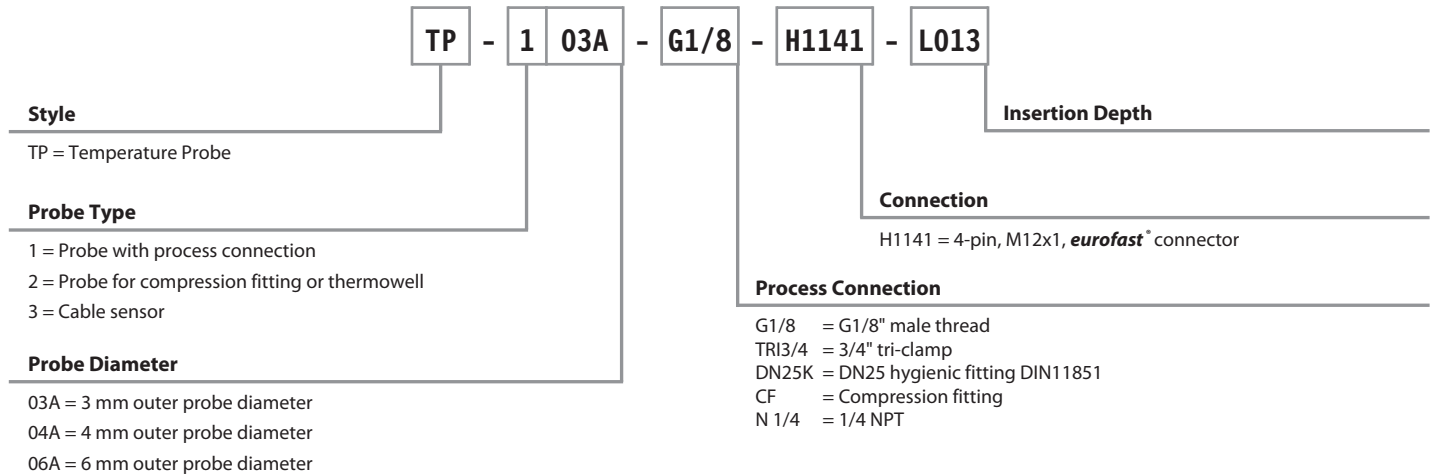

Temperature Probes Specifications

Probe TP-104A ...

Specifications:	
Temperature Operating Range	-50° to 120°C (-58° to +248°F)
Ambient Temperature	-20° to 90°C (-4° to +194°F)
Measuring Element	Pt100, DIN EN 60751, Class A
Response Time	$t_{0.5} = 3 \text{ s}$; $t_{0.9} = 10 \text{ s}$ in water at 0.2 m/s
Output Function	4-wire
Reverse Polarity Protection	Yes
Degree of Protection	IP67
Housing Material	Plastic/Stainless steel
Sensor Material	Stainless steel 1.4404 (AISI 316L)
Pressure Rating (PSI)	580.15
Connection	Connector, M12x1 (<i>eurofast</i>)
Mechanical Connection	Tri-Clamp 3/4"



Temperature Instrumentation

Temperature Probes Specifications

Probes TP-203 .../TP-206 ...

Specifications:	
Temperature Operating Range	-30° to +500°C (-22° to 932°F) 350°C accuracy class A (662°F) 350°C accuracy class B (662°F)
Ambient Temperature	-40° to 90°C (-4° to +194°F)
Measuring Element	Pt100, DIN EN 60751, Class A
Response Time	203: $t_{0.5} = 1.5$ s; $t_{0.9} = 6$ s 206: $t_{0.5} = 6$ s; $t_{0.9} = 15$ s
Output Function	4-wire
Reverse Polarity Protection	Yes
Degree of Protection	IP67
Housing Material	Stainless steel/plastic
Sensor Material	Stainless steel 1.4404 (AISI 316L) mineral insulated
Pressure Rating (psi)	1450
Connection	Connector, M12x1 (euromast)
Mechanical Connection	Use a compression fitting or thermowell



TEMPERATURE

Probe TP-306 ...

Specifications:	
Temperature Operating Range	-50° to +105°C (-58° to +221°F)
Ambient Temperature	-20° to 90°C (-4° to +194°F)
Measuring Element	Pt100, DIN EN 60751, Class A
Response Time	$t_{0.5} = 8$ s; $t_{0.9} = 20$ s in water at 0.2 m/s
Output Function	4-wire
Reverse Polarity Protection	Yes
Degree of Protection	IP67
Housing Material	Plastic/Stainless steel
Cable	TPE (thermoplastic elastomer)
Sensor Material	Stainless steel 1.4404 (AISI 316L)
Pressure Rating (psi)	217
Connection	Connector, M12x1 (euromast)
Mechanical Connection	Use a compression fitting





Temperature Probes

Housing Style	Part Number	ID Number	Temperature Range	Length (mm)
Pt100 Temperature Probe, 3/4" Tri-Clamp, Ø8 mm 	TP-104A-TRI3/4-H1141-L03	M9910429	-50° to +120°C (-58° to +248°F)	35
	TP-104A-TRI3/4-H1141-L100	M9910430	-50° to +120°C (-58° to +248°F)	100
Pt100 Temperature Probe, Ø3 mm 	TP-203A-CF-H1141-L050	M9910645	-30° to +350°C (-22° to +662°F)	50
	TP-203A-CF-H1141-L100	M9910402	-30° to +350°C (-22° to +662°F)	100
	TP-203A-CF-H1141-L150	M9910403	-30° to +350°C (-22° to +662°F)	150
	TP-203A-CF-H1141-L200	M9910482	-30° to +350°C (-22° to +662°F)	200
	TP-203A-CF-H1141-L250	M9910404	-30° to +350°C (-22° to +662°F)	250
	TP-203A-CF-H1141-L300	M9910474	-30° to +350°C (-22° to +662°F)	300
	TP-203A-CF-H1141-L1000	M9910496	-30° to +350°C (-22° to +662°F)	1000
	TP-203A-CF-H1141-L2000	M9910499	-30° to +350°C (-22° to +662°F)	2000
Pt100 Temperature Probe, Ø6 mm 	TP-206A-CF-H1141-L050	M9910646	-30° to +350°C (-22° to +662°F)	50
	TP-206A-CF-H1141-L100	M9910475	-30° to +350°C (-22° to +662°F)	100
	TP-206A-CF-H1141-L150	M9910476	-30° to +350°C (-22° to +662°F)	150
	TP-206A-CF-H1141-L200	M9910477	-30° to +350°C (-22° to +662°F)	200
	TP-206A-CF-H1141-L300	M9910478	-30° to +350°C (-22° to +662°F)	300
	TP-206A-CF-H1141-L500	M9910491	-30° to +350°C (-22° to +662°F)	500

Mating cordset for remote connections; RK 4.4T-* -RS 4.4T.

* Length in millimeters.

For technical data see pages C15 - C16.

See Section F for additional cordset information.



Temperature Probes

Housing Style	Part Number	ID Number	Temperature Range	Length (m)
Pt100 Cable Probe, 4-Pin M12x1 eurofast®, Ø6 mm 	TP-306A-CF-H1141-L1000	M9910479	-50° to +105°C (-58° to +221°F)	1
	TP-306A-CF-H1141-L2000	M9910480		2
	TP-306A-CF-H1141-L5000	M9910481		5

For technical data see page C16.

TEMPERATURE

Housing Style	Part Number	ID Number	Temperature Range	Length (mm)
PT100 RTD, Threaded Process Connection, 4-pin M12x1 eurofast® 	TP-103A-G1/8-H1141-L013	M9910400	-50° to +120°C (-58° to +248°F)	13
	TP-103A-G1/8-H1141-L024	M9910401		24
PT100 RTD, Threaded Process Connection, 4-pin M12x1 eurofast® 	TP-104A-N1/4-H1141-L005	M9910664	-50° to +120°C (-58° to +248°F)	5
	TP-104A-N1/4-H1141-L035	M9910526		35

For technical data see page C16.



Thermowell Part Number Key

THW - 3 - G1/8 - A4 - L013

Thermowell

Probe Diameter

3 = 3 mm probe diameter
 6 = 6 mm probe diameter

Process Connection

G1/8 = G1/8" male thread
 N1/8 = 1/8" NPT male thread
 G1/4 = G1/4" male thread
 N1/4 = 1/4" NPT male thread
 G1/2 = G1/2" male thread
 N1/2 = 1/2" NPT male thread
 TRI3/4 = 3/4" tri-clamp
 DN25K = DN25 hygienic fitting thread DIN 11851
 UNI25 = Universal weld 25 mm

Insertion Depth

Material

A4 = Stainless steel AISI316L



Compression Fittings Part Number Key

CF - M - 3 - G1/8 - A4

Compression Fitting

Compression Ring Material

M = AISI316L
 P = PTFE

Probe Diameter

3 = 3 mm outer diameter
 6 = 6 mm outer diameter

Material

A4 = Stainless steel AISI316L

Process Connection

G1/8 = G1/8" male thread
 N1/8 = 1/8" NPT male thread
 G1/4 = G1/4" male thread
 N1/4 = 1/4" NPT male thread
 N1/2 = 1/2" NPT male thread



Thermowells

Housing Style	Part Number	ID Number	Process Connection	Length (mm)	Compatible Probe Diameter	Pressure Rating (psi)
Thermowell, 1/2" Male NPT 	THW-3-N1/2-A4-L050	M9910447	1/2" NPT	50	3 mm	5800
	THW-3-N1/2-A4-L100	M9910448	1/2" NPT	100	3 mm	5800
	THW-3-N1/2-A4-L150	M9910449	1/2" NPT	150	3 mm	5800
	THW-3-N1/2-A4-L250	M9910450	1/2" NPT	250	3 mm	5800
Thermowell, 1/4" Male NPT 	THW-3-N1/4-A4-L050	M9910416	1/4" NPT	50	3 mm	5800
	THW-3-N1/4-A4-L100	M9910420	1/4" NPT	100	3 mm	5800
	THW-3-N1/4-A4-L150	M9910424	1/4" NPT	150	3 mm	5800
	THW-3-N1/4-A4-L200	M9910428	1/4" NPT	200	3 mm	5800
Thermowell, 1/8" Male NPT 	THW-3-N1/8-A4-L050	M9910414	1/8" NPT	50	3 mm	5800
	THW-3-N1/8-A4-L100	M9910418	1/8" NPT	100	3 mm	5800
	THW-3-N1/8-A4-L150	M9910422	1/8" NPT	150	3 mm	5800
	THW-3-N1/8-A4-L200	M9910426	1/8" NPT	200	3 mm	5800
Thermowell, 3/4" Tri-Clamp 	THW-3-TRI3/4-A4-L035	M9910433	3/4" Tri-Clamp	35	3 mm	580
	THW-3-TRI3/4-A4-L050	M9910451	3/4" Tri-Clamp	50	3 mm	580
Thermowell, Universal Weld 	THW-3-UNI25-A4-L035	M9910502	Weld	35	3 mm	1450

TEMPERATURE

Note: Material is AISI 316L/1.4404



Thermowells

Housing Style	Part Number	ID Number	Process Connection	Length (mm)	Compatible Probe Diameter	Pressure Rating (psi)
Thermowell, 1/2" Male NPT 	THW-6-N1/2-A4-L050	M9910463	1/2" NPT	50	6 mm	5800
	THW-6-N1/2-A4-L100	M9910464	1/2" NPT	100	6 mm	5800
	THW-6-N1/2-A4-L150	M9910465	1/2" NPT	150	6 mm	5800
	THW-6-N1/2-A4-L250	M9910466	1/2" NPT	250	6 mm	5800
Thermowell, 3/4" Tri-Clamp 	THW-6-TRI3/4-A4-L050	M9910467	3/4" Tri-Clamp	50	6 mm	580

Note: Material is AISI 316L/1.4404

Accessories

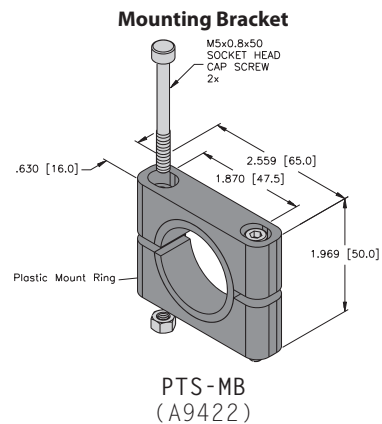
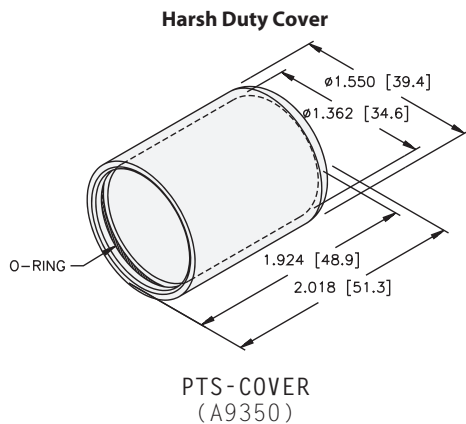

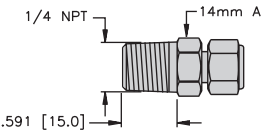
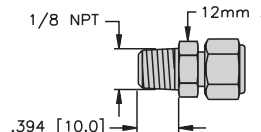
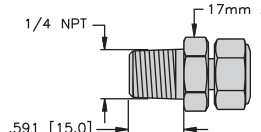
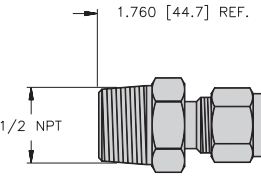

Compression Fittings

Housing Style	Part Number	ID Number	Compatible Probe Diameter	Compression Fitting	Temperature Range	Pressure Rating (psi)
Compression Fitting, 1/4" Male NPT 	CF-M-3-N1/4-A4	M9910408	3 mm	Metal	350°C (662°F)	580
	CF-P-3-N1/4-A4	M9910412	3 mm	PTFE	100°C (212°F)	87
Compression Fitting, 1/8" Male NPT 	CF-M-3-N1/8-A4	M9910406	3 mm	Metal	350°C (662°F)	580
	CF-P-3-N1/8-A4	M9910410	3 mm	PTFE	100°C (212°F)	87
Compression Fitting, 1/4" Male NPT 	CF-M-6-N1/4-A4	M9910484	6 mm	Metal	350°C (662°F)	580
	CF-P-6-N1/4-A4	M9910486	6 mm	PTFE	100°C (212°F)	87
Compression Fitting, 1/2" Male NPT 	CF-M-6-N1/2-A4	A0950	6 mm	Metal	350°C (662°F)	580

TEMPERATURE

Note: Material is AISI 316L/1.4404

TEMPERATURE CONVERTERS

PRODUCT OVERVIEW

WHAT ARE TEMPERATURE CONVERTERS?

Since temperature measurement is common in hazardous areas, TURCK's IM34 temperature converting device may be used to convert a 2, 3 or 4-wire RTD, mV signal or T/C signal in a hazardous area to an analog 4-20 mA signal in a non-hazardous area.



WHY CHOOSE IM34 TEMPERATURE CONVERTERS?

- Several different inputs may be configured and used with common 4-20 mA analog input control cards.
- Consolidate inventory by eliminating separate RTD, T/C and mV input cards.
- Use of off-the-shelf "Simple Apparatus" components in explosive atmospheres to further reduce installation costs.
- Provides advanced diagnostics, versatility and convenience in an easy-to-use device.
- Push button, rotary switch or software (FDT/DTM, free shareware) configurable units are simple to use.

WHERE CAN I USE IM34 TEMPERATURE CONVERTERS?

- Hazardous areas
- Oil and gas processing

Temperature Converters Selection Guide

Part Number	Configuration	Input RTD/TC/OHM/mV	Output Relay	Output 0/4-20mA	Display
IM34-11EX-I	Dip/Rotary Switch	1	No	1	No
IM34-11EX-CI	PACTware	1	No	1	No
IM34-12EX-RI	Dip/Rotary Switch	1	1	1	No
IM34-12EX-CRI	PACTware	1	1	1	No
IM34-14EX-CDRI	Pushbuttons or PACTware	1 (and potentiometer)	3	1	Yes

TEMPERATURE CONVERTERS PRODUCT OVERVIEW



The IM34-14EX-CDRI and similar IM modules can be programmed using PACTware and their relevant DTM. Programming is quick and simple and allows for greater parameters to be set. Configurations can be saved on a PC and downloaded to other units at a later date. In this example, the IM34 is connected to a 4-wire RTD using the RK 4.4T-* cordset. The IM34 has three relay set point outputs and one 0/4-20mA outputs.

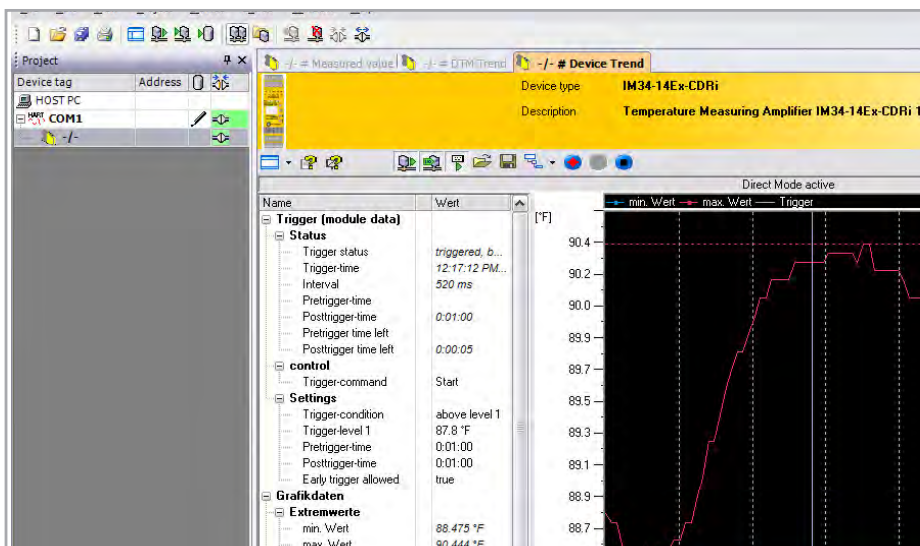
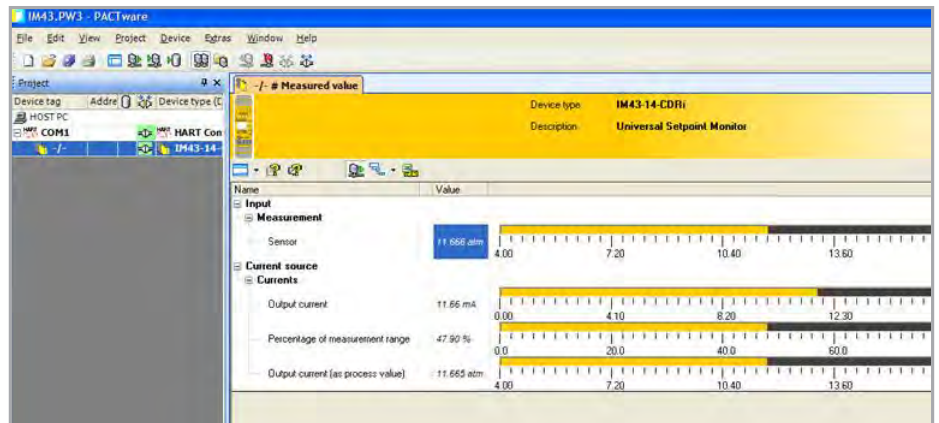

The ability to trend data using PACTware aids in monitoring processes, start-up, commissioning and troubleshooting. Call your local TURCK representative for a full demonstration.

TURCK

Temperature Instrumentation

Notes:





Temperature Instrumentation



Notes:

TEMPERATURE

LEVEL SENSORS SELECTION GUIDE

Housing	Style	Technology	Applications	Page
Flat and QPak 	BC and BCF Capacitive Sensors detect metal and non-metallic targets.	<ul style="list-style-type: none"> ■ Ranges from 5 to 50 mm ■ Flush mount ■ BCF sensors are noise immune ■ Point level detection ■ Variety of rectangular housing 	<ul style="list-style-type: none"> ■ Food and beverage ■ Semiconductor ■ Pharmaceutical ■ Packaging ■ OEM 	E9
Barrels 	BC, BCF, BCC Capacitive Sensors detect metal and non-metallic targets.	<ul style="list-style-type: none"> ■ 12, 18 and 30 mm barrels ■ High temperature versions up to 100°C ■ Chemically resistant versions ■ BCF sensors are noise immune ■ BCC sensors for low dielectrics 	<ul style="list-style-type: none"> ■ Food and beverage ■ Semiconductor ■ Pharmaceutical ■ Packaging ■ Plastics ■ OEM 	E21
Level Probe 	R16 Level Probe uses magnetostrictive technology to monitor the position of a magnetic float along the sensing rod.	<ul style="list-style-type: none"> ■ Liquid Level Sensor ■ Continuous level detection ■ FM approved ■ IP68 ■ 3A rated 	<ul style="list-style-type: none"> ■ Food and beverage ■ Pharmaceutical ■ Hazardous areas 	E47
Converters 	IM33 / IM43 Analog and Level Converters These units will power level probes, transmitters and convert voltage and current analog signals.	<ul style="list-style-type: none"> ■ 2, 3 or 4-wire ■ Voltage and current input ■ Output 4-20 mA ■ Display models ■ Relay and transistor outputs ■ PACTware compatible models 	<ul style="list-style-type: none"> ■ Hazardous areas ■ Safe areas ■ Analog setpoints 	E57
Conductive Rods 	Conductive Rods detect resistance between two steel rods is measured to determine the level of the conductive liquid.	<ul style="list-style-type: none"> ■ Point level detection ■ Adjustable sensitivity ■ Single set points ■ Multiple inputs ■ On/Off delay ■ Programmable outputs 	<ul style="list-style-type: none"> ■ Wastewater ■ OEM 	E59

Product	Liquid Detection	Dry Goods Detection	High/Low Level Detection	Continuous Level Detection	Point Level Detection	Non-Intrusive
Capacitive Sensors	X	X	X		X	X
R16 Level Probe	X			X		
Conductive Rods	X		X		X	
Pressure Sensor	X		X	X	X	

CAPACITIVE LEVEL SENSORS

PRODUCT OVERVIEW

WHAT ARE TURCK'S CAPACITIVE SENSORS?

Capacitive sensors have the ability to "see through" lower dielectric materials, such as plastic or glass, to detect higher dielectric ones. This allows capacitive sensors to detect levels of many types of materials either directly through the wall for plastic tanks, or by utilizing a sight glass or tank well for metal tanks.

WHY CHOOSE TURCK'S CAPACITIVE SENSORS?

- **Q-Pak**® capacitive sensors are available in packages up to 10 times narrower than conventional barrel-style sensors.
- Extensive NAMUR offering for intrinsically safe applications; from flatpack housings to 12-30 mm barrels.
- Wide sensitivity band allows for detection of a variety of granular or powdered materials.
- NAMUR, PVDF and PTFE tank wells can be used in explosive or corrosive materials.

WHERE CAN I USE TURCK'S CAPACITIVE SENSORS?

- Liquid level control for explosive and non-explosive environments.
- Package inspection for product content and/or fill level.
- Wire-break detection for wire sizes down to .003".
- Plastic pellet detection in a hopper for injection molding processes.
- Grain or food products level detection; intrinsically safe models available.
- Small metal parts detection for greater sensing range than comparable inductive sensors.
- Semiconductor and chemical industries.

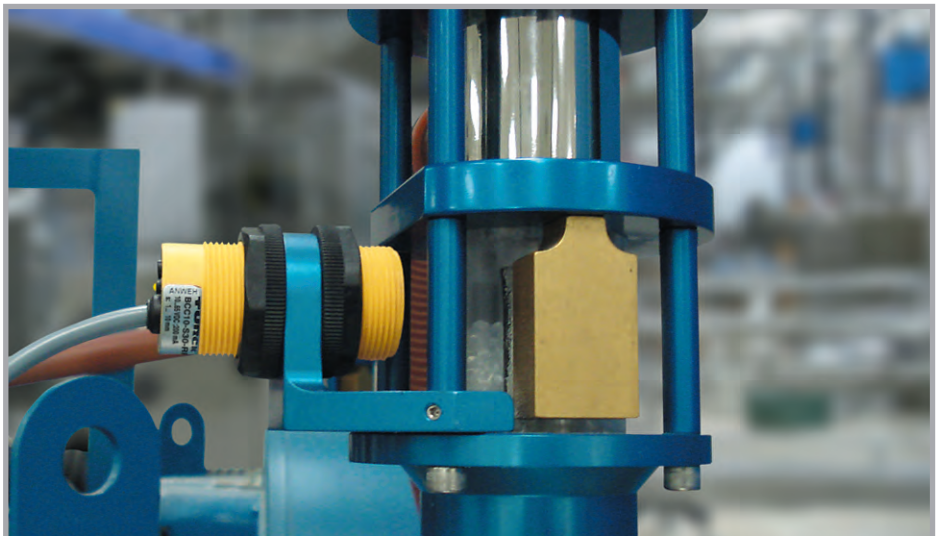

CAPACITIVE LEVEL SENSORS

PRODUCT OVERVIEW

HOW DO I ADJUST THE SENSITIVITY OF A CAPACITIVE SENSOR?

Many applications require adjusting the sensitivity of the capacitive sensor in order to reliably detect the target material. Although the potentiometer is factory set for an operating distance of 0.7 to 0.8 times the rated operating distance, it can be easily changed. The rated operating distance is set using the standard target which is a grounded piece of mild steel.

Most TURCK capacitive sensors are listed as embeddable. By increasing the sensitivity, the embeddable sensor can be changed into a non-embeddable version with enhanced sensing capabilities. Capacitive sensors can be adjusted two ways in order to sense a target consistently.

- 1. Physical adjustment** – moving the sensor towards or away from the target is the preferred method of adjusting sensitivity when the sensor is not in direct contact with the target. This allows materials to be moved into or out of range while leaving the sensor at the factory setting or after re-calibration to the nominal operating distance S_n .
- 2. Adjustment of the potentiometer** – turning the potentiometer in a clockwise direction increases the sensitivity of the sensor. The potentiometer is factory-set for an operating distance of 0.7 to 0.8 S_n to a grounded standard target (Figure 1). It should be adjusted in increments of no greater than a quarter-turn (Figure 2). Increasing the sensitivity results in a greater operating distance to both conductive and non-conductive targets.

When sensing non-conductive targets, the larger the dielectric constant of a material, the greater the achievable operating distance (Figure 3). Adjusting the potentiometer affects the total curve; for example, if the potentiometer is adjusted for less sensitivity, it will have less operating distance to all materials.

In general terms, the larger the dielectric constant of a material (ϵ), the greater the achievable operating distance.

The dielectric constant of the material is a measure of its insulation properties. All liquids and solids have a greater dielectric constant than air ($\epsilon_{\text{air}} = 1$). Therefore, the capacitance with a non-metallic target present is always greater than the capacitance of the circuit in the absence of the target.

When detecting organic materials the sensing distance will depend largely on the water content ($\epsilon_{\text{water}} = 88$).

It should be noted that a large increase in sensitivity will cause the sensor to become nonembeddable, and may result in an unstable switching point that can be influenced by environmental changes such as temperature, humidity, dust, etc.

At adjustments of $S > S_n$, the differential travel (hysteresis) can also increase.

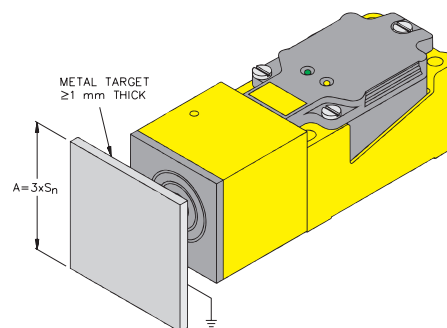

Figure 1

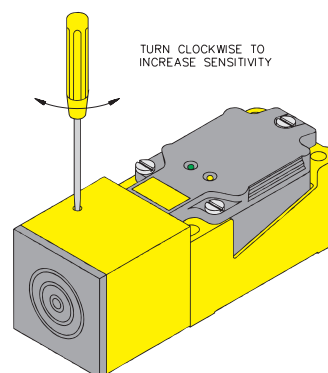
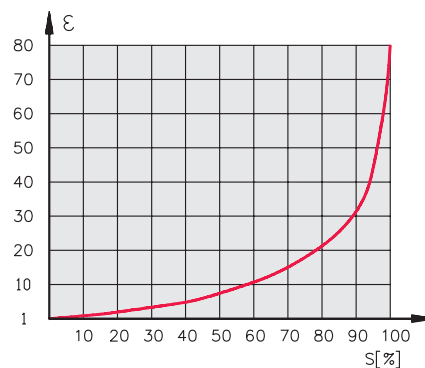

Figure 2



RELATION OF OPERATING DISTANCE TO DIELECTRIC CONSTANT

Figure 3

CAPACITIVE LEVEL SENSORS

PRODUCT OVERVIEW

Operating Principle

The active element is formed by two metallic electrodes positioned much like an "opened" capacitor (Figure 5). Electrodes A and B are placed in a feedback loop of a high frequency oscillator. When no target is present, the sensor's capacitance is low, therefore the oscillation amplitude is small. When a target approaches the face of the sensor, it increases the capacitance. This increase in capacitance results in an increased amplitude of oscillation. The amplitude of oscillation is measured by an evaluating circuit that generates a signal to turn on or off the output (Figure 4).

Capacitance is a function of the surface area of either electrodes (A or B), the distance between the electrodes (d), and the dielectric constant of the material (ϵ) between the electrodes (Figure 5).

When a **Conductive Target** enters the sensor's field, it forms a counter electrode to the active face of the sensor, thus decreasing the distance between the electrodes (d) and increasing their average surface area (Figure 6). The capacitance with a metal target present is always greater than the capacitance of the circuit in the absence of the target.

Reduction factors for different metals are not a consideration when using capacitive sensors.

When a **Non-Conductive Target** enters the sensor's field, it acts as an electrical insulator between electrodes A and B (Figure 7).

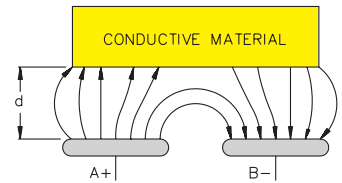

Figure 6

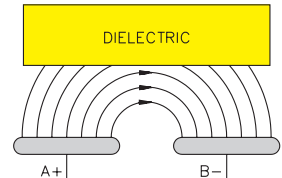

Figure 7

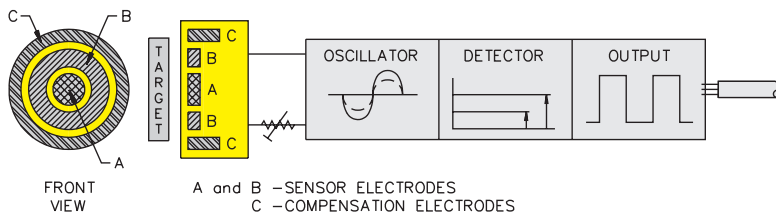

Figure 4

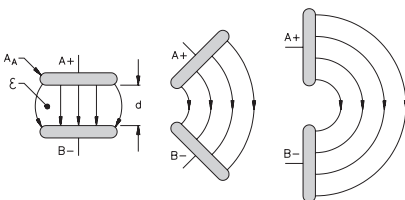

Figure 5

CAPACITIVE LEVEL SENSORS

PRODUCT OVERVIEW

CAN I USE CAPACITIVE SENSORS IN AREAS WITH HIGH ELECTROMAGNETIC NOISE?

Capacitive sensors were originally designed for use in areas that were generally far away from other electrical equipment. As factory automation has become more prevalent throughout industrial market, these capacitive sensors have gravitated into new environments where electrical noise levels are present. Electrical noise can be produced by various sources, including variable frequency drives, electro-mechanical motors and standard walkie-talkie devices. These “noisy” environments can have adverse effects on sensing devices causing them to operate improperly.

TURCK developed a new circuit for its BCF capacitive sensors that incorporates a fixed oscillator frequency combined with a rectifier filter that makes the sensors immune to most industrial noise. The list of specifications and test results below demonstrates how TURCK meets or exceeds all of the rigid standards established by CE. In fact, the criteria set forth by CE is so stringent that most capacitive sensors offered on the market today cannot pass any or all of these testing requirements. If you have a capacitive sensor application located in a “noisy” environment, choose the BCF sensors from TURCK to ensure your process operates smoothly.



Test Type		TURCK BCC Capacitive Sensors	CE “Product” Standard	CE “Generic” Standard
Immunity to Electrostatic Discharge (ESD)	IEC 1000-4-2 EN 61000-4-2	8 kV Direct Contact 30 kV Airborne	4 kV Direct Contact 8 kV Airborne	4 kV Direct Contact 8 kV Airborne
Immunity to Radiated Electromagnetic Fields. Radio Frequency Interference (RFI)	3 V/M 80-1000 MHz	15 V/M 80-1000 MHz	3 V/M 80-1000 MHz	3 V/M 80-1000 MHz
Immunity to Electrical Fast Transients (Burst-High Voltage)	IEC 1000-4-4 EN 61000-4-4	3000 V	2000 V	2000 V
Immunity to Conducted R.F. Voltage (Line coupled Noise)	IEC 1000-4-6 EN 61000-4-6	>10 V 150 kHz-230 MHz	Undefined	10 V 150 kHz-80 MHz
Immunity to Surges (lightning strike)	IEC 255-5	1 kV, 500 Ω DC 5 kV, 500 Ω AC	1 kV, 500 Ω DC	Undefined

Level Sensors - Capacitive

Capacitive Sensor Part Number Key

B	C	20	-	K	40	SR	-	F	Z	3	X2	Wiring Options	Special Option Codes										
Mounting B = Embeddable N = Nonembeddable			Principle of Operation C = Capacitive CF = Capacitive (Noise immune)			Rated Operating Distance (mm)			Housing Style Barrel - Metal M = Partial Threading, Chrome Plated Brass Barrel - Plastic K = Smooth KT = PVDF, Smooth P = Full Threading PT = PVDF, Full Threading S = Partial Threading Rectangular Q = Metal or Plastic, Various Rectangular Styles QF = Plastic, Rectangular - Flat Q20L60 = Plastic, Rectangular Limit Switch CP = <i>combiprox</i> [®] , Plastic Housing, Terminal Chamber Base with Removable Sensor Head			Number of LEDs Examples: Blank = No LEDs X2 = 2 LEDs			Voltage Range AC: 3 = 20-250 VAC (Not SCP) DC: 4 = 10-65 VDC, Polarity Protected, Pulsed SCP** 6 = 10-30 VDC, Polarity Protected, Pulsed SCP**			Output N = NPN Transistor (Current Sinking) P = PNP Transistor (Current Sourcing) Z = 2-Wire AC			Output Function A = Normally Open (N.O.) F = Connection Programmable (N.O. or N.C.) R = Normally Closed (N.C.) V = Complementary Outputs: One N.O., One N.C. Y0 = NAMUR Output, Requires Switching Amplifier		
Housing Diameter/Height (mm)			Housing Modifier SR = Straight Terminal Chamber																				

CAPACITIVE

Wiring Options

A) Connectorized Sensor

BC10-M30-AP4X- H1 1 4 1

Connector Family	Factory Code
B1 = <i>minifast</i> [®] , Metal, Male B2 = <i>minifast</i> [®] , Plastic, Male B3 = <i>microfast</i> [®] , Metal, Male H1 = <i>eurofast</i> [®] , Metal or Plastic, Male V1 = <i>picofast</i> [®] , Metal, Male	Example: 1 = Standard 3 = N.C. DC Output on Pin 4 (for US)
	Number of Pins
	1 = Straight

B) Potted Cable

BC 5-S18-AP4X- 7M

Cable Length
Blank = 2 Meter cable 7M = 7 Meter cable

C) Cable / Connector Option

BCF 5-S18-AP4X- 0.2 - RS 4T

Cable Length	Connector
0.2 Meter cable	RS 4T = <i>eurofast</i> [®] , Male

TURCK

Level Sensors - Capacitive

Capacitive Sensor General Specifications

3-Wire DC Capacitive - AP6X, AN6X

Ripple	10%
Differential Travel (Hysteresis)	2-20% (5% typical)
Voltage Drop Across Conducting Sensor	1.8 V at 200 mA
Trigger Current for Overload Protection	220 mA
Off-State (Leakage) Current	<100 A
No-Load Current	15 mA
Power-On Effect	Per IEC 947-5-2
Reverse Polarity Protection	Yes
Wire-Break Protection	Yes
Transient Protection	Per EN 60947-5-2
Shock	30 g, 11 ms
Vibration	55 Hz, 1 mm Amplitude in all 3 Planes
Repeatability	2% of Rated Operating Distance
Temperature Drift	$\leq 20\%$ of Rated Operating Distance
Short-circuit Protection	Yes

4-Wire DC Capacitive - VP4X, VN4X

Ripple	10%
Differential Travel (Hysteresis)	2-20 (5% typical)
Voltage Drop Across Conducting Sensor	1.8 V at 200 mA
Trigger Current for Overload Protection	220 mA
Leakage (Off-State) Current	<100 A
No-Load Current	15 mA
Power-On Effect	Per IEC 947-5-2
Reverse Polarity Protection	Incorporated
Wire-Break Protection	Incorporated
Transient Protection	Per EN 60947-5-2
Shock	30 g, 11 ms
Vibration	55 Hz, 1 mm Amplitude in all 3 Planes
Repeatability	2% of Rated Operating Distance
Temperature Drift	$\leq 20\%$ of Rated Operating Distance
Short-circuit Protection	Yes

Capacitive Sensor General Specifications

2-Wire AC Capacitive - AZ3X	
Line Frequency	40-60 Hz
Differential Travel (Hysteresis)	3-15% (5% typical)
Voltage Drop Across Conducting Sensor	6.0 V at 400 mA 8 & 12 mm 6.0 V at 100 mA
Continuous Load Current	400 mA 8 & 12 mm 100 mA
Off-State (Leakage) Current	1.7 mA
Minimum Load Current	5.0 mA
Inrush Current	8.0 A (10 ms, 5% Duty Cycle)
Power-On Effect	Per IEC 947-5-2
Transient Protection	Per EN 60947-5-2
Shock	30 g, 11 ms
Vibration	55 Hz, 1 mm Amplitude in all 3 Planes
Repeatability	2% of Rated Operating Distance
Short-circuit Protection	No

2-Wire DC NAMUR Capacitive - Y1X	
Differential Travel (Hysteresis)	1-10% (5% typical)
Nominal Voltage	8.2 VDC (EN60947-5-6)
Resistance Change from Nonactivated to Activated Condition	Typical <1.0 to >8.0 k
Resulting Current Change	2.2 mA to 1.0 mA
Recommended Switching Point for Remote Amplifier	>1.2 to <2.1 mA, typ. 1.55 mA ON/1.75 mA OFF
Power-On Effect	Realized in Amplifier
Reverse Polarity Protection	Incorporated
Wire-Break Protection	Realized in Amplifier
Transient Protection	Realized in Amplifier
Shock	30 g, 11 ms
Vibration	55 Hz, 1 mm Amplitude in all 3 Planes
Repeatability	2% of Rated Operating Distance

CAPACITIVE

TURCK

Level Sensors - Capacitive



Housing Style	Part Number	ID Number	Features	Embeddable Range (mm)	Nonembed. Range (mm)	Output
5.5 mm - Embeddable, Potted-In Cable 	BC 5-QF5.5-AN6X2/S250	S2620120	No Potentiometer	5	5	3-Wire DC NPN
	BC10-QF5.5-AN6X2	S2620121		10	10	
	BC10-QF5.5-AN6X2/S250	S2620119	No Potentiometer	10	10	
	BC10-QF5.5-RN6X2			10	10	
	BC 5-QF5.5-AP6X2/S250	S2620116	No Potentiometer	5	5	3-Wire DC PNP
	BC 5-QF5.5-RP6X2/S250		No Potentiometer	5	5	
	BC10-QF5.5-AP6X2	S2620117		10	10	
	BC10-QF5.5-AP6X2/S250	S2620115	No Potentiometer	10	10	
	BC10-QF5.5-RP6X2		Normally Closed	10	10	
	BC10-QF5.5-RP6X2/S250		No Potentiometer	10	10	
BC 5-QF5.5-Y1X/S250	S2030000	No Potentiometer	5	5	2-Wire DC NAMUR	
5.5 mm - Embeddable, Potted-In Cable, w/Potentiometer Cover 	BC10-QF5.5-AN6X2/S932	S2620137	Covered Pot.	10	10	3-Wire DC NPN
	BC10-QF5.5-RN6X2/S932	S2620140	Covered Pot.	10	10	
	BC10-QF5.5-AP6X2/S932	S2620109	Covered Pot.	10	10	3-Wire DC PNP
	BC10-QF5.5-RP6X2/S932	S2620141	Covered Pot.	10	10	
8 mm - Embeddable, Potted-In Cable 	BC 5-Q08-AN6X2/S250	S2620100	No Potentiometer	5	5	3-Wire DC NPN
	BC 5-Q08-AP6X2/S250	S2620000	No Potentiometer	5	5	3-Wire DC PNP
8 mm - Embeddable, picofast® Connector 	BC 5-Q08-AN6X2-V1131/S250	S2621100	No Potentiometer	5	5	3-Wire DC NPN
	BC 5-Q08-AP6X2-V1131/S250	S2621000	No Potentiometer	5	5	3-Wire DC PNP

"/S250" designates without potentiometer.
"/S932" designates Covered potentiometer.

Level Sensors - Capacitive

Voltage	Switching Freq. (Hz)	Operating Current (mA)	Operating Temp. (°C)	Protection Class	Housing Material	Face/ Front Cap	Power LED	Output LED	Mating Cord, Cable Length/ Jacket	Wiring Diagram #	Wiring Diagrams
10-30 VDC	100	200	-25 to +70	IP67	PP	PP	GN	YE	2M/TPU	1	Diagram 1
	100	200	-25 to +70	IP67	PP	PP	GN	YE	2M/TPU	1	
	100	200	-25 to +70	IP67	PP	PP	GN	YE	2M/TPU	1	
	100	200	-25 to +70	IP67	PP	PP	GN	YE	2M/TPU	5	
10-30 VDC	100	200	-25 to +70	IP67	PP	PP	GN	YE	2M/TPU	2	Diagram 2
	100	200	-25 to +70	IP67	PP	PP	GN	YE	2M/TPU	6	
	100	200	-25 to +70	IP67	PP	PP	GN	YE	2M/TPU	2	
	100	200	-25 to +70	IP67	PP	PP	GN	YE	2M/TPU	2	
	100	200	-25 to +70	IP67	PP	PP	GN	YE	2M/TPU	6	
5-30 VDC	100	Remote	-25 to +70	IP67	PP	PP	N/A	YE	2M/TPU	5	Diagram 3
10-30 VDC	100	200	-25 to +70	IP67	PP	PP	GN	YE	2M/TPU	1	
	100	200	-25 to +70	IP67	PP	PP	GN	YE	2M/TPU	5	
10-30 VDC	100	200	-25 to +70	IP67	PP	PP	GN	YE	2M/TPU	2	
	100	200	-25 to +70	IP67	PP	PP	GN	YE	2M/TPU	6	
10-30 VDC	100	200	-25 to +70	IP67	Zinc	PA 12	GN	YE	2M/TPU	1	Diagram 5
10-30 VDC	100	200	-25 to +70	IP67	Zinc	PA 12	GN	YE	2M/TPU	2	Diagram 6
10-30 VDC	100	200	-25 to +70	IP67	Zinc	PA 12	GN	YE	PKG 3Z-*	3	
10-30 VDC	100	200	-25 to +70	IP67	Zinc	PA 12	GN	YE	PKG 3Z-*	4	

CAPACITIVE

* Length in meters.

TURCK

Level Sensors - Capacitive



Housing Style	Part Number	ID Number	Features	Embeddable Range (mm)	Nonembed. Range (mm)	Output
10 mm - Embeddable, Potted-In Cable 	BC 8-Q10-AN6X2/S250	S2621203	No Potentiometer	8	8	3-Wire DC NPN
	BC 8-Q10-AP6X2/S250	S2621200	No Potentiometer	8	8	3-Wire DC PNP
10 mm - Embeddable, pcofast® Connector 	BC 8-Q10-AP6X2-V1131/S250	S2621201	No Potentiometer	8	8	3-Wire DC PNP
14 mm - Embeddable, Potted-In Cable 	BC10-Q14-AN4X2	M2530010		10	15	3-Wire DC NPN
	BC10-Q14-AN4X2/S400	M2530005	Rear LED	10	15	
	BC10-Q14-AP4X2	M2530001		10	15	3-Wire DC PNP
	BC10-Q14-AP4X2/S400	M2530003	Rear LED	10	15	
	BC10-Q14-VN4X2	M2530030	Comp. Outputs	10	15	4-Wire DC NPN
	BC10-Q14-VP4X2	M2530020	Comp. Outputs	10	15	4-Wire DC PNP
14 mm - Embeddable, pcofast Connector 	BC10-Q14-AN4X2-V1131/S400	M2530006	Rear LED	10	15	3-Wire DC NPN
	BC10-Q14-AP4X2-V1131	M2530002		10	15	3-Wire DC PNP
	BC10-Q14-AP4X2-V1131/S400	M2530004	Rear LED	10	15	

"/S250" in part number designates without potentiometer.

"/S400" in part number designates rear LED location on back of sensor opposite front face.

Level Sensors - Capacitive

Voltage	Switching Freq. (Hz)	Operating Current (mA)	Operating Temp. (°C)	Protection Class	Housing Material	Power LED	Output LED	Mating Cord, Cable Length/ Jacket	Wiring Diagram #	Wiring Diagrams
10-30 VDC	100	200	-25 to +70	IP67	PBT-GF30-V0	GN	YE	2M/PVC	1	Diagram 1
10-30 VDC	100	200	-25 to +70	IP67	PBT-GF30-V0	GN	YE	2M/PVC	2	Diagram 2
10-30 VDC	100	200	-25 to +70	IP67	PBT-GF30-V0	GN	YE	PKG 3M-*	4	Diagram 3
										Diagram 4
10-65 VDC	100	200	-25 to +70	IP67	PBT-GF30-V0	GN	YE	2M/PVC	1	Diagram 5
	100	200	-25 to +70	IP67	PBT-GF30-V0	GN	YE	2M/PVC	1	
10-65 VDC	100	200	-25 to +70	IP67	PBT-GF30-V0	GN	YE	2M/PVC	2	Diagram 6
	100	200	-25 to +70	IP67	PBT-GF30-V0	GN	YE	2M/PVC	2	
10-65 VDC	100	200	-25 to +70	IP67	PBT-GF30-V0	GN	YE	2M/PVC	5	
10-65 VDC	100	200	-25 to +70	IP67	PBT-GF30-V0	GN	YE	2M/PVC	6	
10-65 VDC	100	200	-25 to +70	IP67	PBT-GF30-V0	GN	YE	PKG 3M-*	3	
10-65 VDC	100	200	-25 to +70	IP67	PBT-GF30-V0	GN	YE	PKG 3M-*	4	
	100	200	-25 to +70	IP67	PBT-GF30-V0	GN	YE	PKG 3M-*	4	

CAPACITIVE

* Length in meters.

TURCK

Level Sensors - Capacitive



Housing Style	Part Number	ID Number	Features	Embeddable Range (mm)	Nonembed. Range (mm)	Output
10 mm - Embeddable, Potted-In Cable 	BCF10-Q20L60-AP4X	M2504028	Noise Immune	10	20	3-Wire DC PNP

Level Sensors - Capacitive

Voltage	Operating Current (mA)	Operating Temp. (°C)	Protection Class	Housing Material	Power LED	Output LED	Mating Cord/ Cable Length/ Jacket	Wiring Diagram #	Wiring Diagrams
10-65 VDC	200	-25 to 70	IP67	PBT-GF20-V0	None	YE	2M/PVC	1	<p>Diagram 1</p>

* Length in meters.

CAPACITIVE

TURCK

Level Sensors - Capacitive



Housing Style	Part Number	ID Number	Features	Embeddable Range (mm)	Nonembed. Range (mm)	Output
20 mm - Embeddable, Potted-In Cable 	BC20-Q20-AN4X2	M2530110		20	30	3-Wire DC NPN
	BC20-Q20-AN4X2/S400	M2530104	Rear LED	20	30	
	BC20-Q20-AP4X2	M2530100		20	30	3-Wire DC PNP
	BC20-Q20-AP4X2/S400	M2530102	Rear LED	20	30	
	BC20-Q20-AZ3X2	M4352000		20	30	2-Wire AC
	BC20-Q20-AZ3X2/S400	M2310005	Rear LED	20	30	

"/S400" in part number designates rear LEDs, located on back of sensor opposite of sensing face.

Level Sensors - Capacitive

Voltage	Switching Freq. (Hz)	Operating Current (mA)	Operating Temp. (°C)	Protection Class	Housing Material	Power LED	Output LED	Mating Cord Length/Jacket	Wiring Diagram #	Wiring Diagrams
10-65 VDC	100	200	-25 to +70	IP67	PBT-GF30-V0	GN	YE	2M/PVC	1	Diagram 1
	100	200	-25 to +70	IP67	PBT-GF30-V0	GN	YE	2M/PVC	1	
10-65 VDC	100	200	-25 to +70	IP67	PBT-GF30-V0	GN	YE	2M/PVC	2	Diagram 2
	100	200	-25 to +70	IP67	PBT-GF30-V0	GN	YE	2M/PVC	2	
20-250 VAC	20	500	-25 to +70	IP67	PBT-GF30-V0	GN	YE	2M/PVC	3	Diagram 3
	20	500	-25 to +70	IP67	PBT-GF30-V0	GN	YE	2M/PVC	3	

CAPACITIVE

TURCK

Level Sensors - Capacitive



Housing Style	Part Number	ID Number	Features	Embeddable Range (mm)	Nonembed. Range (mm)	Output
20 mm - Embeddable, eurofast® Connector 	BC20-Q20-AN4X2-H1141	M2530111		20	30	3-Wire DC NPN
	BC20-Q20-AP4X2-H1141	M2530101		20	30	3-Wire DC PNP
	BC20-Q20-AP4X2-H1141/S400	M2530103	Rear LED	20	30	
	BC20-Q20-VN4X2-H1141	M2530131	Comp. Outputs	20	30	4-Wire DC NPN
	BC20-Q20-VN4X2-H1141/S400	M2530124	Comp. Outputs Rear LED	20	30	
	BC20-Q20-VP4X2-H1141	M2530121	Comp. Outputs	20	30	4-Wire DC PNP
	BC20-Q20-VP4X2-H1141/S400	M2530123	Comp. Outputs Rear LED	20	30	

"/S400" in part number designates rear LEDs, located on back of sensor opposite of sensing face.

Level Sensors - Capacitive

Voltage	Switching Freq. (Hz)	Operating Current (mA)	Operating Temp. (°C)	Protection Class	Housing Material	Power LED	Output LED	Mating Cord, Cable Length/ Jacket	Wiring Diagram #	Wiring Diagrams
10-65 VDC	100	200	-25 to +70	IP67	PBT-GF30-V0	GN	YE	RK 4T-*	1	Diagram 1
	100	200	-25 to +70	IP67	PBT-GF30-V0	GN	YE	RK 4T-*	2	
10-65 VDC	100	200	-25 to +70	IP67	PBT-GF30-V0	GN	YE	RK 4T-*	2	Diagram 2
	100	200	-25 to +70	IP67	PBT-GF30-V0	GN	YE	RK 4T-*	2	
10-65 VDC	100	200	-25 to +70	IP67	PBT-GF30-V0	GN	YE	RK 4.4T-*	3	Diagram 3
	100	200	-25 to +70	IP67	PBT-GF30-V0	GN	YE	RK 4.4T-*	3	
10-65 VDC	100	200	-25 to +70	IP67	PBT-GF30-V0	GN	YE	RK 4.4T-*	4	Diagram 4
	100	200	-25 to +70	IP67	PBT-GF30-V0	GN	YE	RK 4.4T-*	4	

CAPACITIVE

* Length in meters.

TURCK

Level Sensors - Capacitive



Housing Style	Part Number	ID Number	Features	Embeddable Range (mm)	Nonembed. Range (mm)	Output
40 mm - Embeddable, Terminal Chamber 	BC20-CP40-VN4X2	M2515700	Comp. Outputs	20	30	4-Wire DC NPN
	BC20-CP40-VP4X2	M2515600	Comp. Outputs	20	30	4-Wire DC PNP
	BC20-CP40-FZ3X2	M2311500	Prog. Outputs	20	30	2-Wire AC
80 mm - Nonembeddable, Terminal Chamber 	NC50-CP80-VN4X2	M2580112	Comp. Outputs	NA	50	4-Wire DC NPN
	NC50-CP80-VP4X2	M2580212	Comp. Outputs	NA	50	4-Wire DC PNP
	NC50-CP80-FZ3X2	M2310610	Prog. Outputs	NA	50	2-Wire AC

Level Sensors - Capacitive

Voltage	Switching Freq. (Hz)	Operating Current (mA)	Operating Temp. (°C)	Protection Class	Housing Material	Power LED	Output LED	Mating Cordset	Wiring Diagram #	Wiring Diagrams
10-65 VDC	100	200	-25 to +70	IP67	PBT-GF30-V0	GN	YE	----	1	<p>Diagram 1</p>
10-65 VDC	100	200	-25 to +70	IP67	PBT-GF30-V0	GN	YE	----	2	<p>Diagram 2</p>
20-250 VAC	20	500	-25 to +70	IP67	PBT-GF30-V0	GN	YE	----	3	<p>Diagram 3</p>
10-65 VDC	200	200	-25 to +70	IP67	PBT-GF30-V0	GN	YE	----	1	
10-65 VDC	200	200	-25 to +70	IP67	PBT-GF30-V0	GN	YE	----	2	<p>-OR-</p>
20-250 VAC	20	500	-25 to +70	IP67	PBT-GF30-V0	GN	YE	----	3	

CAPACITIVE

TURCK

Level Sensors - Capacitive



Housing Style	Part Number	ID Number	Features	Embeddable Range (mm)	Nonembed. Range (mm)	Output
12 mm - Embeddable, eurofast® Connector 	BC 3-M12-AN6X-0.2M-RS 4T	M2601190		3	3	3-Wire DC NPN
	BC 3-M12-AP6X-0.2M-RS 4T	M2601091		3	3	3-Wire DC PNP
12 mm - Embeddable, Potted-In Cable 	BC 3-M12-AN6X	M2601100		3	3	3-Wire DC NPN
	BC 3-M12-AP6X	M2601000		3	3	3-Wire DC PNP
12 mm - Embeddable, eurofast Connector 	BC 3-S12-AN6X-0.2M-RS 4T	M2601390		3	4.5	3-Wire DC NPN
	BC 3-S12-AP6X-0.2M-RS 4T	M2601291		3	4.5	3-Wire DC PNP
12 mm - Embeddable, Potted-In Cable 	BC 3-S12-AN6X	M2601300		3	4.5	3-Wire DC NPN
	BC 3-S12-AP6X	M2601200		3	4.5	3-Wire DC PNP
	BC 3-S12-AP6X/S100	M2601201	High Temp. 100°C	3	4.5	

Level Sensors - Capacitive

Voltage	Switching Freq. (Hz)	Operating Current (mA)	Operating Temp. (°C)	Protection Class	Housing Material	Face Material	End Cap	Power LED	Output LED	Mating Cord, Cable Length/Jacket	Wiring Diagram #	Wiring Diagrams
10-30 VDC	100	200	-25 to +70	IP67	CPB	ABS	PA	N/A	YE	RK 4T-*	1	<p>Diagram 1</p>
10-30 VDC	100	200	-25 to +70	IP67	CPB	ABS	PA	N/A	YE	RK 4T-*	2	<p>Diagram 2</p>
10-30 VDC	100	200	-25 to +70	IP67	CPB	ABS	PA	N/A	YE	2M/PVC	3	<p>Diagram 3</p>
10-30 VDC	100	200	-25 to +70	IP67	CPB	ABS	PA	N/A	YE	2M/PVC	4	<p>Diagram 4</p>
10-30 VDC	100	200	-25 to +70	IP67	PA 12-GF30	PA	PA	N/A	YE	RK 4T-*	1	
10-30 VDC	100	200	-25 to +70	IP67	PA 12-GF30	PA	PA	N/A	YE	RK 4T-*	2	
10-30 VDC	200	200	-25 to +70	IP67	PA 12-GF30	PA	PA	N/A	YE	2M/PVC	3	
10-30 VDC	100	200	-25 to +70	IP67	PA 12-GF30	PA	PA	N/A	YE	2M/PVC	4	
	100	200	-25 to +100	IP67	PA 12-GF30	PA	PA	N/A	YE	2M/PVC	4	

CAPACITIVE

* Length in meters..

TURCK

Level Sensors - Capacitive



Housing Style	Part Number	ID Number	Embeddable Range (mm)	Nonembed. Range (mm)	Output
18 mm - Embeddable, eurofast® Connector 	BC 5-M18-AN4X-0.2M-RS 4T	M2504091	5	5	3-Wire DC NPN
	BC 5-M18-AP4X-0.2M-RS 4T	M2504090	5	5	3-Wire DC PNP
18 mm - Embeddable, microfast® Connector 	BC 5-M18-AZ3X-0.2M-SB 3T	M2305090	5	5	2-Wire AC
18 mm - Embeddable, Potted-In Cable 	BC 5-M18-AN4X	M2504002	5	5	3-Wire DC NPN
	BC 5-M18-AP4X	M2504001	5	5	3-Wire DC PNP
	BC 5-M18-AZ3X	M2305000	5	5	2-Wire AC

Level Sensors - Capacitive

Voltage	Switching Freq. (Hz)	Operating Current (mA)	Operating Temp. (°C)	Protection Class	Housing Material	Face Material	End Cap	Power LED	Output LED	Mating Cord, Cable Length/Jacket	Wiring Diagram #	Wiring Diagrams
10-65 VDC	100	200	-25 to +70	IP67	CPB	PBT-G30-V0	PUR	N/A	YE	RK 4T-*	1	<p>Diagram 1</p>
10-65 VDC	100	200	-25 to +70	IP67	CPB	PBT-G30-V0	PUR	N/A	YE	RK 4T-*	2	<p>Diagram 2</p>
20-250 AC	20	500	-25 to +70	IP67	CPB	PBT-G30-V0	PUR	N/A	YE	KB 3T-*	5	<p>Diagram 3</p> <p>Diagram 4</p>
10-65 VDC	100	200	-25 to +70	IP67	CPB	PBT-G30-V0	PUR	N/A	YE	2M/PVC	3	<p>Diagram 5</p>
10-65 VDC	100	200	-25 to +70	IP67	CPB	PBT-G30-V0	PUR	N/A	YE	2M/PVC	4	<p>Diagram 6</p>
20-250 VAC	20	500	-25 to +70	IP67	CPB	PBT-G30-V0	PUR	N/A	YE	2M/PVC	6	

CAPACITIVE

* Length in meters.

TURCK

Level Sensors - Capacitive



Housing Style	Part Number	ID Number	Features	Embeddable Range (mm)	Nonembed. Range (mm)	Output
18 mm - Embeddable, eurofast[®] Connector 	BC 5-S18-AN4X-0.2M-RS 4T	M2503192		5	7.5	3-Wire DC NPN
	BC 5-S18-AN4X-H1141/S250	M2503108	No Potentiometer	5	7.5	
	BCF 5-S18-AN4X-0.2M-RS 4T	M2503089	Noise Immune	5	7.5	
	BC 5-S18-AP4X-0.2M-RS 4T	M2503492		5	7.5	3-Wire DC PNP
	BC 5-S18-AP4X-H1141/S250	M2503602	No Potentiometer	5	7.5	
	BCF 5-S18-AP4X-0.2M-RS 4T	M2503099	Noise Immune	5	7.5	
18 mm - Embeddable, eurofast Connector 	BC 5-S185-AN4X-0.3M-RS 4T	M2503590	Chemical Resistant	5	7.5	3-Wire DC NPN
	BC 5-S185-AP4X-0.2M-RS 4T	M2503591	Chemical Resistant	5	7.5	3-Wire DC PNP
18 mm - Embeddable, microfast[®] Connector 	BC 5-S18-AZ3X-0.2M-SB 3T	M2305590		5	7.5	2-Wire AC

"/S250" in part number designates without potentiometer.

Level Sensors - Capacitive

Voltage	Switching Freq. (Hz)	Operating Current (mA)	Operating Temp. (°C)	Protection Class	Housing Material	End Cap	Power LED	Output LED	Mating Cordset	Wiring Diagram #	Wiring Diagrams
10-65 VDC	100	200	-25 to +70	IP67	PA 12-GF30	PUR	N/A	YE	RK 4T-*	1	<p>Diagram 1</p>
	100	200	-25 to +70	IP67	PA 12-GF30	PUR	N/A	YE	RK 4T-*	1	
	100	200	-25 to +70	IP67	PA 12-GF30	PUR	N/A	YE	RK 4T-*	1	
10-65 VDC	100	200	-25 to +70	IP67	PA 12-GF30	PUR	N/A	YE	RK 4T-*	2	<p>Diagram 2</p>
	100	200	-25 to +70	IP67	PA 12-GF30	PUR	N/A	YE	RK 4T-*	2	
	100	200	-25 to +70	IP67	PA 12-GF30	PUR	N/A	YE	RK 4T-*	2	
10-65 VDC	100	200	-25 to +70	IP67	PVDF	PUR	N/A	YE	RK 4T-*	1	<p>Diagram 3</p>
10-65 VDC	100	200	-25 to +70	IP67	PVDF	PUR	N/A	YE	RK 4T-*	2	
20-250 VAC	20	500	-25 to +70	IP67	PA12-GF30	PUR	N/A	YE	KB 3T-*	3	

* Length in meters.

CAPACITIVE

TURCK

Level Sensors - Capacitive



Housing Style	Part Number	ID Number	Features	Embeddable Range (mm)	Nonembed. Range (mm)	Output
18 mm - Embeddable, Potted-In Cable 	BC 5-S18-AN4X	M2503100		5	7.5	3-Wire DC NPN
	BCF 5-S18-AN4X	M2503012	Noise Immune	5	7.5	
	BC 5-S18-AP4X	M2503000		5	7.5	3-Wire DC PNP
	BCF 5-S18-AP4X	M2503011	Noise Immune	5	7.5	
	BCF 5-S18-AP4X/S90	M2503014	Noise Immune	5	7.5	
	BC 5-S18-AZ3X	M2305500			5	7.5
18 mm - Embeddable, Potted-In Cable 	BC 5-S185-AN4X	M2503550	Chemical Resistant	5	7.5	3-Wire DC NPN
	BC 5-S185-AN4X/S100	M2503551	High Temp. 100°C	5	7.5	
	BC 5-S185-AP4X	M2503500	Chemical Resistant	5	7.5	3-Wire DC PNP
	BC 5-S185-AP4X/S100	M2503502	High Temp. 100°C	5	7.5	
18 mm - Embeddable, Potted-In Cable 	BC 5-S18-Y1X	M2006000		5	7.5	2-Wire DC NAMUR

"/S100" in part number designates high temperature sensor.

Level Sensors - Capacitive

Voltage	Switching Freq. (Hz)	Operating Current (mA)	Operating Temp. (°C)	Protection Class	Housing Material	End Cap	Power LED	Output LED	Cable Length/ Material	Wiring Diagram #	Wiring Diagrams
10-65 VDC	100	200	-25 to +70	IP67	PA 12-GF30	PUR	N/A	YE	2M/PVC	1	Diagram 1
	100	200	-25 to +70	IP67	PA 12-GF30	PUR	N/A	YE	2M/PVC	1	
10-65 VDC	100	200	-25 to +70	IP67	PA 12-GF30	PUR	N/A	YE	2M/PVC	2	Diagram 2
	100	200	-25 to +70	IP67	PA 12-GF30	PUR	N/A	YE	2M/PVC	2	
	100	200	-25 to +70	IP67	PA 12-GF30	PUR	N/A	YE	2M/PUR	2	
20-250 VAC	20	500	-25 to +70	IP67	PA 12-GF30	PUR	N/A	YE	2M/PVC	3	Diagram 3
10-65 VDC	100	200	-25 to +70	IP67	PVDF	PUR	N/A	YE	2M/PVC	1	Diagram 4
	100	200	-25 to +100	IP67	PVDF	PUR	N/A	YE	2M/PVC	1	
10-65 VDC	100	200	-25 to +70	IP67	PVDF	PUR	N/A	YE	2M/PVC	2	Diagram 4
	100	200	-25 to +100	IP67	PVDF	PUR	N/A	YE	2M/PVC	2	
5-30 VDC	100	Remote	-25 to +70	IP67	PA 12-GF30	PUR	N/A	YE	2M/PVC	4	

CAPACITIVE

TURCK

Level Sensors - Capacitive



Housing Style	Part Number	ID Number	Features	Embeddable Range (mm)	Nonembed. Range (mm)	Output
30 mm - Embeddable, eurofast™ Connector 	BC10-M30K-AN4X-H1141	M2503030		10	10	3-Wire DC NPN
	BC10-M30K-AP4X-H1141	M2503026		10	10	3-Wire DC PNP
	BC10-M30K-VN4X-H1141	M2503033	Comp. Outputs	10	10	4-Wire DC NPN
	BC10-M30K-VP4X-H1141	M2503035	Comp. Outputs	10	10	4-Wire DC PNP
30 mm - Embeddable, microfast™ Connector 	BC10-M30K-AZ3X-B3131	M2503034		10	10	2-Wire AC N.O.
	BC10-M30K-RZ3X-B3131	M2503023		10	10	2-Wire AC N.C.

Level Sensors - Capacitive

Voltage	Switching Freq. (Hz)	Operating Current (mA)	Operating Temp. (°C)	Protection Class	Housing Material	Face Material	End Cap	Power LED	Output LED	Mating Cordset	Wiring Diagram #	Wiring Diagrams
10-65 VDC	100	200	-25 to +70	IP67	CPB	PA 12-GF30	PA 66-GF25-V0	N/A	YE	RK 4T-*	1	<p>Diagram 1</p>
10-65 VDC	100	200	-25 to +70	IP67	CPB	PA 12-GF30	PA 66-GF25-V0	N/A	YE	RK 4T-*	2	<p>Diagram 2</p>
10-65 VDC	100	200	-25 to +70	IP67	CPB	PA 12-GF30	PA 66-GF25-V0	N/A	YE	RK 4.4T-*	3	<p>Diagram 3</p>
10-65 VDC	100	200	-25 to +70	IP67	CPB	PA 12-GF30	PA 66-GF25-V0	N/A	YE	RK 4.4T-*	4	<p>Diagram 4</p>
20-250 AC	20	500	-25 to +70	IP67	CPB	PA 12-GF30	PA 66-GF25-V0	N/A	YE	KB 3T-*	5	<p>Diagram 5</p>
20-250 AC	20	500	-25 to +70	IP67	CPB	PA 12-GF30	PA 66-GF25-V0	N/A	YE	KB 3T-*	6	<p>Diagram 6</p>

CAPACITIVE

* Length in meters.

TURCK

Level Sensors - Capacitive



Housing Style	Part Number	ID Number	Features	Embeddable Range (mm)	Nonembed. Range (mm)	Output
30 mm - Embeddable, Potted-In Cable 	BC10-M30K-VN4X	M2503024	Comp. Outputs	10	10	4-Wire DC NPN
	BC10-M30K-VP4X	M2503022	Comp. Outputs	10	10	4-Wire DC PNP
	BC10-M30K-AZ3X	M2503031		10	10	2-Wire AC N.O.
	BC10-M30K-RZ3X	M2503025		10	10	2-Wire AC N.C.

Level Sensors - Capacitive

Voltage	Switching Freq. (Hz)	Operating Current (mA)	Operating Temp. (°C)	Protection Class	Housing Material	Face Material	End Cap Material	Power LED	Output LED	Cable Length/Jacket	Wiring Diagram #	Wiring Diagrams
10-65 VDC	100	200	-25 to +70	IP67	CPB	PA 12-GF30	PA 66-GF25-V0	N/A	YE	2M/PVC	1	<p>Diagram 1</p> <p>Diagram 2</p>
10-65 VDC	100	200	-25 to +70	IP67	CPB	PA 12-GF30	PA 66-GF25-V0	N/A	YE	2M/PVC	2	<p>Diagram 3</p> <p>Diagram 4</p>
20-250 VAC	20	500	-25 to +70	IP67	CPB	PA 12-GF30	PA 66-GF25-V0	N/A	YE	2M/PVC	3	<p>Diagram 3</p> <p>Diagram 4</p>
20-250 VAC	20	500	-25 to +70	IP67	CPB	PA 12-GF30	PA 66-GF25-V0	N/A	YE	2M/PVC	4	<p>Diagram 3</p> <p>Diagram 4</p>

CAPACITIVE

* Length in meters.

TURCK

Level Sensors - Capacitive



Housing Style	Part Number	ID	Features	Embeddable Range (mm)	Nonembed. Range (mm)	Output	
30 mm - Embeddable, eurofast[®] Connector 	BCC10-S30-AP4X-H1141	M2503038	Low Dielectric Targets	10	10	3-Wire DC PNP	
	BCC10-S30-RP4X-H1143	M1542562	Low Dielectric Targets	10	10	3-Wire DC PNP N.C.	
	BC10-S30-VN4X-H1141	M2506010	Comp. Outputs	10	15	4-Wire DC NPN	
	BCF10-S30-VN4X-H1141	M2506016	Noise Immune	10	15		
	BC10-S30-VP4X-H1141	M2506100	Comp. Outputs	10	15	4-Wire DC PNP	
	BCC10-S30-VP4X-H1141	M2503043	Low Dielectric Targets	10	10		
	BCF10-S30-VP4X-H1141	M2506117	Noise Immune	10	15		
	30 mm - Embeddable, microfast[®] Connector 	BC10-S30-AZ3X-B3131	M2310710		10	15	2-Wire AC N.O.
		BCF10-S30-AZ3X-B3131	M2506012	Noise Immune	10	15	
		BC10-S30-RZ3X-B3131	M2310810			10	15
BCF10-S30-RZ3X-B3131		M2506014	Noise Immune	10	15		

Level Sensors - Capacitive

Voltage	Switching Freq. (Hz)	Operating Current (mA)	Operating Temp. (°C)	Protection Class	Housing Material	End Cap Material	Power LED	Output LED	Mating Cordset	Wiring Diagram #	Wiring Diagrams
10-65 VDC	100	200	-25 to +70	IP67	PA12-GF30	PA 66-GF25-V0	N/A	YE	RK 4T-*	5	Diagram 1
	100	200	-25 to +70	IP67	PA12-GF30	PA 66-GF25-V0	N/A	YE	RK 4T-*	6	Diagram 2
10-65 VDC	100	200	-25 to +70	IP67	PA12-GF30	PA 66-GF25-V0	N/A	YE	RK 4.4T-*	1	Diagram 3
	100	200	-25 to +70	IP67	PA12-GF30	PA 66-GF25-V0	N/A	YE	RK 4.4T-*	1	Diagram 3
10-65 VDC	100	200	-25 to +70	IP67	PA12-GF30	PA 66-GF25-V0	N/A	YE	RK 4.4T-*	2	Diagram 4
	100	200	-25 to +70	IP67	PA12-GF30	PA 66-GF25-V0	N/A	YE	RK 4.4T-*	2	Diagram 4
	100	200	-25 to +70	IP67	PA12-GF30	PA 66-GF25-V0	N/A	YE	RK 4.4T-*	2	Diagram 4
20-250 VAC	20	500	-25 to +70	IP67	PA12-GF30	PA 66-GF25-V0	N/A	YE	KB 3T-*	3	Diagram 5
	20	500	-25 to +70	IP67	PA12-GF30	PA 66-GF25-V0	N/A	YE	KB 3T-*	3	Diagram 5
20-250 VAC	20	500	-25 to +70	IP67	PA12-GF30	PA 66-GF25-V0	N/A	YE	KB 3T-*	4	Diagram 6
	20	500	-25 to +70	IP67	PA12-GF30	PA 66-GF25-V0	N/A	YE	KB 3T-*	4	Diagram 6

CAPACITIVE

* Length in meters.

TURCK

Level Sensors - Capacitive

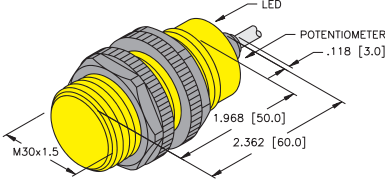
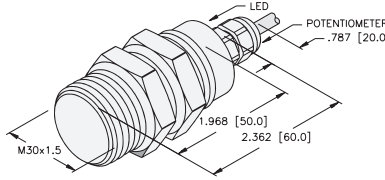
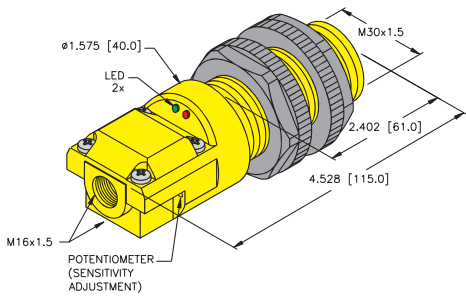

Housing Style	Part Number	ID	Features	Embeddable Range (mm)	Nonembed. Range (mm)	Output
30 mm - Embeddable, Potted-In Cable 	BC10-S30-VN4X	M2506000	Comp. Outputs	10	15	4-Wire DC NPN
	BCF10-S30-VN4X	M2506011	Noise Immune	10	15	
	BC10-S30-VP4X	M2506110	Comp. Outputs	10	15	4-Wire DC PNP
	BCF10-S30-VP4X	M2506111	Noise Immune	10	15	
	BC10-S30-AZ3X	M2310700		10	15	2-Wire AC
	BCF10-S30-AZ3X	M2506015	Noise Immune	10	15	
	BC10-S30-Y1X	M2010000		10	15	2-Wire DC NAMUR
30 mm - Embeddable, Potted-In Cable 	BC10-PT30-VN4X2	M2507020	Chemical Resistant	10	15	4-Wire DC NPN
	BC10-PT30-VP4X2	M2507010	Chemical Resistant	10	15	4-Wire DC PNP
	BC10-PT30-Y0X	M2020000	Chemical Resistant	10	15	2-Wire DC NAMUR
30 mm - Embeddable, Terminal Chamber 	BC10-P30SR-VN4X2	M2505100	Comp. Outputs	10	15	4-Wire DC NPN
	BC10-P30SR-VP4X2	M2505000	Comp. Outputs	10	15	4-Wire DC PNP

"/S359" designates Capacitive sensor with external potentiometer located on 2 meter cable.

Level Sensors - Capacitive

Voltage	Switching Freq. (Hz)	Operating Current (mA)	Operating Temp. (°C)	Protection Class	Housing Material	End Cap Material	Power LED	Output LED	Cable Length/ Material	Wiring Diagram #	Wiring Diagrams
10-65 VDC	100	200	-25 to +70	IP67	PA 12-GF30	PA 66-GF25-V0	N/A	YE	2M/PVC	1	Diagram 1
	100	200	-25 to +70	IP67	PA 12-GF30	PA 66-GF25-V0	N/A	YE	2M/PVC	1	
10-65 VDC	100	200	-25 to +70	IP67	PA 12-GF30	PA 66-GF25-V0	N/A	YE	2M/PVC	2	Diagram 2
	100	200	-25 to +70	IP67	PA 12-GF30	PA 66-GF25-V0	N/A	YE	2M/PVC	2	
20-250 VAC	20	500	-25 to +70	IP67	PA 12-GF30	PA 66-GF25-V0	N/A	YE	2M/PVC	3	Diagram 3
	20	500	-25 to +70	IP67	PA 12-GF30	PA 66-GF25-V0	N/A	YE	2M/PVC	3	
5-30 VDC	100	N/A	-25 to +70	IP67	PA 12-GF30	PA 66-GF25-V0	N/A	YE	2M/PVC	4	
10-65 VDC	100	200	-25 to +70	IP67	PVDF	PVDF	GN	YE	2M/PVDF	1	Diagram 4
10-65 VDC	100	200	-25 to +70	IP67	PVDF	PVDF	GN	YE	2M/PVDF	2	
5-30 VDC	100	Remote	-25 to +70	IP67	PVDF	PVDF	N/A	YE	2M/PVDF	4	Diagram 5
10-65 VDC	100	200	-25 to +70	IP67	ABS	ABS	GN	YE	- - - -	5	Diagram 6
10-65 VDC	100	200	-25 to +70	IP67	ABS	ABS	GN	YE	- - - -	6	Diagram 7

CAPACITIVE

TURCK

Level Sensors - Capacitive

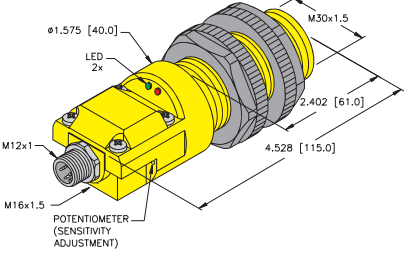
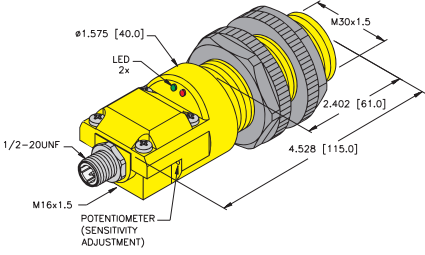
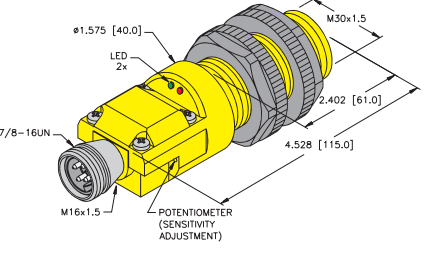

Housing Style	Part Number	ID Number	Features	Embeddable Range (mm)	Nonembed. Range (mm)	Output
30 mm - Embeddable, eurofast[®] Connector 	BC10-P30SR-VN4X2-H1141	M2505192	Comp. Outputs	10	15	4-Wire DC NPN
	BC10-P30SR-VP4X2-H1141	M2505094	Comp. Outputs	10	15	4-Wire DC PNP
30 mm - Embeddable, microfast[®] Connector 	BC10-P30SR-FZ3X2-B3131	M2310491	Comp. Outputs	10	15	2-Wire AC
30 mm - Embeddable, minifast[®] Connector 	BC10-P30SR-VN4X2-B2141	M2505193	Comp. Outputs	10	15	4-Wire DC NPN
	BC10-P30SR-VP4X2-B1141	M2505092	Comp. Outputs	10	15	4-Wire DC PNP
	BC10-P30SR-VP4X2-B2141	M2505093	Comp. Outputs	10	15	
	BC10-P30SR-FZ3X2-B1131	M2310490	Comp. Outputs	10	15	2-Wire AC
	BC10-P30SR-FZ3X2-B2131	M2310493	Comp. Outputs	10	15	

Level Sensors - Capacitive

Voltage	Switching Freq. (Hz)	Operating Current (mA)	Operating Temp. (°C)	Protection Class	Housing Materials	End Cap Materials	Power LED	Output LED	Cable Length/ Material	Wiring Diagram #	Wiring Diagrams
10-65 VDC	100	200	-25 to +70	IP67	ABS	ABS	GN	YE	RK 4.4T-*	1	<p>Diagram 1</p>
10-65 VDC	100	200	-25 to +70	IP67	ABS	ABS	GN	YE	RK 4.4T-*	2	<p>Diagram 2</p>
20-250 AC	200	500	-25 to +70	IP67	ABS	ABS	GN	YE	KB 3T-*	3	<p>Diagram 3</p>
20-250 AC	200	500	-25 to +70	IP67	ABS	ABS	GN	YE	KB 3T-*	3	<p>Diagram 4</p>
10-65 VDC	100	200	-25 to +70	IP67	ABS	ABS	GN	YE	RK 40-*M	4	<p>Diagram 5</p>
10-65 VDC	100	200	-25 to +70	IP67	ABS	ABS	GN	YE	RKM 40-*M	5	<p>Diagram 6</p>
	100	200	-25 to +70	IP67	ABS	ABS	GN	YE	RK 40-*M	5	
20-250 AC	20	500	-25 to +70	IP67	ABS	ABS	GN	YE	RKM 30-*M	6	<p>Diagram 6</p>
	20	500	-25 to +70	IP67	ABS	ABS	GN	YE	RK 30-*M	6	

CAPACITIVE

TURCK

Level Sensors - Capacitive



Housing Style	Part Number	ID Number	Features	Embeddable Range (mm)	Nonembed. Range (mm)	Output
34 mm - Embeddable, eurofast® Connector 	BC15-K34-AN4X-H1141	M2502125		15	23	3-Wire DC NPN
	BC15-K34-AP4X-H1141	M2502126		15	23	3-Wire DC PNP
34 mm - Embeddable, Potted-In Cable 	BC15-K34-VN4X	M2502127	Comp. Outputs	15	23	4-Wire DC NPN
	BC15-K34-VP4X	M2502124	Comp. Outputs	15	23	4-Wire DC PNP
	BC15-K34-AZ3X	M2310008		15	23	2-Wire AC
BCF15-K34-AZ3X	M2502136	Noise Immune	15	23		
34 mm - Nonembeddable, Potted-In Cable 	NC20-KT34-VP4X2	M2550300	Chemical Resistant Comp. Output	N/A	20	4-Wire DC PNP

Level Sensors - Capacitive

Voltage	Switching Freq. (Hz)	Operating Current (mA)	Operating Temp. (°C)	Protection Class	Housing Material	End Cap Material	Power LED	Output LED	Mating Cord, Cable Length/Jacket	Wiring Diagram #	Wiring Diagrams
10-65 VDC	100	200	-25 to +70	IP67	PBT-GF30-V0	ABS	N/A	YE	RK 4T-*	1	<p>Diagram 1</p> <p>Diagram 2</p> <p>Diagram 3</p> <p>Diagram 4</p> <p>Diagram 5</p>
10-65 VDC	100	200	-25 to +70	IP67	PBT-GF30-V0	ABS	N/A	YE	RK 4T-*	2	<p>Diagram 1</p> <p>Diagram 2</p> <p>Diagram 3</p> <p>Diagram 4</p> <p>Diagram 5</p>
10-65 VDC	100	200	-25 to +70	IP67	PBT-GF30-V0	ABS	N/A	YE	2M/PVC	3	<p>Diagram 1</p> <p>Diagram 2</p> <p>Diagram 3</p> <p>Diagram 4</p> <p>Diagram 5</p>
10-65 VDC	100	200	-25 to +70	IP67	PBT-GF30-V0	ABS	N/A	YE	2M/PVC	4	<p>Diagram 1</p> <p>Diagram 2</p> <p>Diagram 3</p> <p>Diagram 4</p> <p>Diagram 5</p>
20-250 VAC	20	500	-25 to +70	IP67	PBT-GF30-V0	ABS	N/A	YE	2M/PVC	5	<p>Diagram 1</p> <p>Diagram 2</p> <p>Diagram 3</p> <p>Diagram 4</p> <p>Diagram 5</p>
	20	500	-25 to +70	IP67	PBT-GF30-V0	ABS	N/A	YE	2M/PVC	5	
10-65 VDC	200	200	-25 to +70	IP67	PVDF	PVDF	GN	YE	2M/PVDF	4	<p>Diagram 1</p> <p>Diagram 2</p> <p>Diagram 3</p> <p>Diagram 4</p> <p>Diagram 5</p>

* Length in meters.

CAPACITIVE

TURCK

Level Sensors - Capacitive



Housing Style	Part Number	ID Number	Features	Embeddable Range (mm)	Nonembed. Range (mm)	Output
34 mm - Embeddable, Terminal Chamber 	BC15-K34SR-VN4X2	M2502128	Comp. Outputs	15	23	4-Wire DC NPN
	BC15-K34SR-VP4X2	M2502129	Comp. Outputs	15	23	4-Wire DC PNP
	BC15-K34SR-FZ3X2	M2310009	Prog. Outputs	15	23	2-Wire AC
40 mm - Embeddable, Terminal Chamber 	BC20-K40SR-VN4X2	M2510100	Comp. Outputs	20	30	4-Wire DC NPN
	BC20-K40SR-VP4X2	M2510000	Comp. Outputs	20	30	4-Wire DC PNP
	BC20-K40SR-FZ3X2	M2310300	Prog. Outputs	20	30	2-Wire AC
40 mm - Embeddable, Terminal Chamber, IP69k 	BC20-K40WDTC-VP4X2/S930	M2510105	Sealed LED's Potentiometer	20	30	4-Wire DC PNP

Level Sensors - Capacitive

Voltage	Switching Freq. (Hz)	Operating Current (mA)	Operating Temp. (°C)	Protection Class	Housing Material	End Cap Material	Power LED	Output LED	Mating Cordset	Wiring Diagram #	Wiring Diagrams
10-65 VDC	100	200	-25 to +70	IP67	PBT-GF30-V0	ABS	GN	YE	- - - -	1	<p>Diagram 1</p>
10-65 VDC	100	200	-25 to +70	IP67	PBT-GF30-V0	ABS	GN	YE	- - - -	2	<p>Diagram 2</p>
20-250 VAC	20	500	-25 to +70	IP67	PBT-GF30-V0	ABS	GN	YE	- - - -	3	<p>Diagram 3</p>
10-65 VDC	100	200	-25 to +70	IP67	ABS	ABS	GN	YE	- - - -	1	
10-65 VDC	100	200	-25 to +70	IP67	ABS	ABS	GN	YE	- - - -	2	<p>-OR-</p>
20-250 VAC	20	500	-25 to +70	IP67	ABS	ABS	GN	YE	- - - -	3	
10-65 VDC	100	200	-25 to +70	IP69k	LV-30	LV-30	GN	YE		2	

CAPACITIVE

TURCK

Level Sensors - Capacitive

Tank Wells

Part Number	ID Number	Material	Thread Size	Drill Size	Application
TWD-18S	A5055	POM	3/4-14 NPT	59/64	18 mm threaded capacitive sensors for liquid level sensing.
TWT-18S	A5050	PTFE	3/4-14 NPT	59/64	18 mm threaded capacitive sensors for liquid level sensing.
TWD-18S-1NPT	A5057	POM	1-11½ NPT	1-5/32	18 mm threaded capacitive sensors for liquid level sensing.
TWT-18S-1NPT	A5056	PTFE	1-11½ NPT	1-5/32	18 mm threaded capacitive sensors for liquid level sensing.

Pressure Rating: 150 psi
Inches [mm]

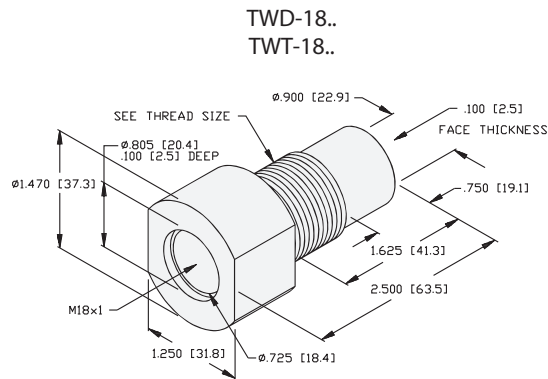

Part Number	ID Number	Material	Thread Size	Drill Size	Application
TWT-30S-SHORT	A5062	PTFE	1¼-11½ NPT	1½	30 mm threaded capacitive sensors for liquid level sensing.
TWD-30S-SHORT	A5063	POM	1¼-11½ NPT	1½	30 mm threaded capacitive sensors for liquid level sensing.

Pressure Rating: 150 psi
Inches [mm]

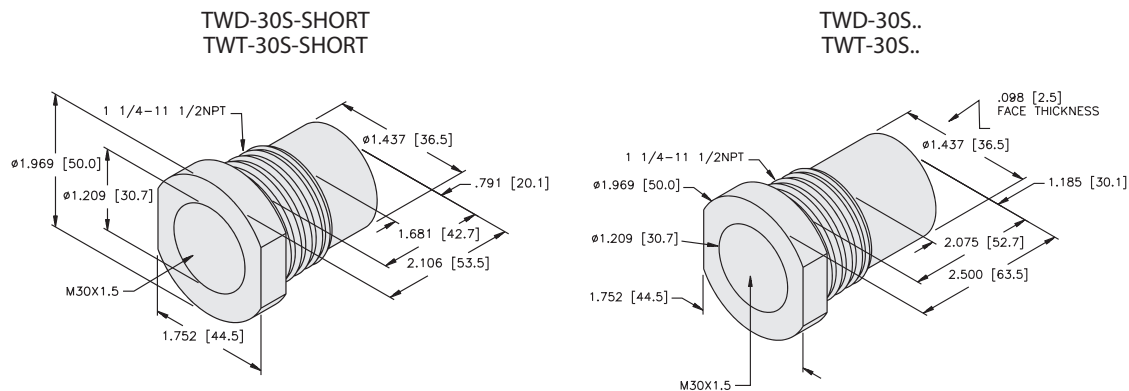

Sight Glass Mounts

Part Number	ID Number	Dimensions			
		A	B	C	D
TWTS-1.5-30	A5077	M30x1.5	1.500 [38.1]	1.984 [50.4]	1.000 [25.4]
TWTS-2-30	A5076	M30x2.0	2.008 [51.0]	2.520 [64.0]	1.000 [25.4]

Material: PTFE
Inches [mm]

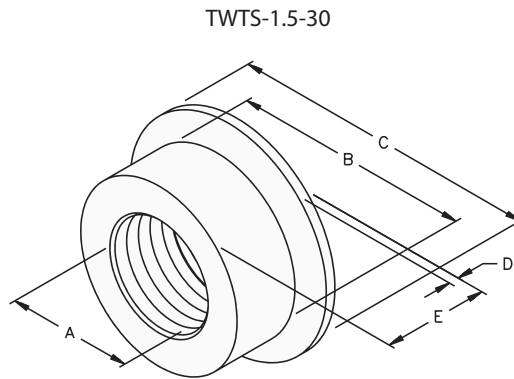

CAPACITIVE

Part Number	ID Number	Dimensions			
		A	B	C	D
TSG-12	A2500	1.75 [44.5]	1.25 [31.8]	12 mm (threaded or non-threaded)	0.37-0.81 [9.40-20.6]
TSG-18	A2501	1.90 [48.3]	1.48 [37.5]	18 mm (threaded or non-threaded)	0.63-1.12 [16.0-28.4]
TSG-30	A2502	3.45 [87.6]	2.00 [50.8]	30 mm (threaded or non-threaded)	1.00-1.75 [25.4-44.5]

Material: POM
Inches [mm]

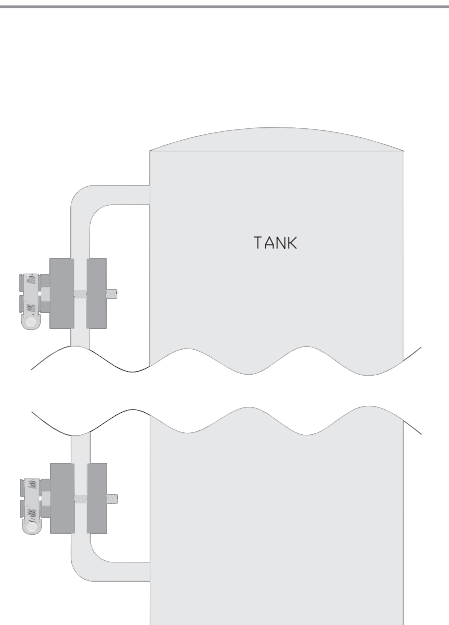
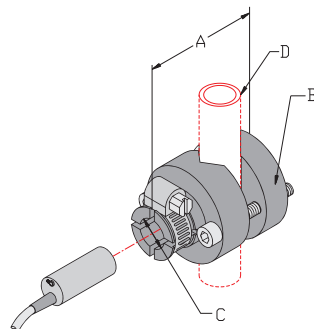

TURCK

Level Sensors - Capacitive

Dielectric Constants of Industrial Products

Material	Dielectric Constant
ABS resin, pellet	1.5 - 2.5
Acetic Acid	4.1
Acetone	19.5
Acetyl bromide	16.5
Acrylic resin	2.7 - 4.5
Air	1.0
Alcohol, industrial	16 - 31
Alcohol, isopropyl	18.3
Ammonia	15 - 25
Aniline	5.5 - 7.8
Aqueous solutions	50 - 80
Asbestos	3.0
Ash (fly)	1.7
Bakelite	3.6
Barley powder	3.0 - 4.0
Benzene	2.3
Benzyl acetate	5
Butane	1.4
Cable sealing compound	2.5
Calcium carbonate	9.1
Carbon Dioxide	1.6
Carbon tetrachloride	2.2
Celluloid	3.0
Cellulose	3.2 - 7.5
Cement	1.5 - 2.1
Cement powder	5 - 10
Cereal	3 - 5
Charcoal	1.2 - 1.8
Chlorine, liquid	2.0
Coke	1.1 - 2.2
Corn	5 - 10
Ebonite	2.7 - 2.9

Material	Dielectric Constant
Epoxy resin	2.5 - 6
Ethanol	24
Ethyl bromide	4.9
Ethylene Chloride	10.5
Ethylene Dichloride	11.0
Ethylene glycol	38.7
Ethylene Oxide	14.0
Ferrous Oxide	14.2
Fired Ash	1.5
Flour	2.5 - 3.0
Formic Acid	59.0
Freon® R22 & 502, liquid	6.1
Gasoline	2.2
Glass	3.1 - 10
Glass, raw material	2.0 - 2.5
Glycerine	47
Hexane	1.9
Hydrochloric Acid	4.6
Hydrogen cyanide	95.4
Hydrogen peroxide	84.2
Ice, -5C	2.85
Ice, -18C	3.16
Isobutylamine	4.5
Lime, shell	1.2
Marble	8.0 - 8.5
Melamine resin	4.7 - 10.2
Methane, liquid	1.7
Methanol	33.6
Mica, white	4.5 - 9.6
Milk, powdered	3.5 - 4
Nitrobenzene	36
Neoprene	6 - 9

Dielectric Constants of Industrial Products

Material	Dielectric Constant
Nylon	4 - 5
Oil, for transformer	2.2 - 2.4
Oil, paraffin	2.2 - 4.8
Oil, peanut	3.0
Oil, petroleum	2.1
Oil, soybean	2.9 - 3.5
Oil, turpentine	2.2
Paint	5 - 8
Paraffin	1.9 - 2.5
Paper	1.6 - 2.6
Paper, hard	4.5
Paper, oil saturated	4.0
Perspex	3.2 - 3.5
Petroleum	2.0 - 2.2
Phenol	9.9 - 15
Phenol resin	4.9
Polyacetal (Delrin®)	3.6
Polyamide (nylon)	2.5
Polycarbonate	2.9
Polyester resin	2.8 - 8.1
Polyethylene	2.3
Polypropylene	2.0 - 2.3
Polystyrene	3.0
Polyvinyl Chloride resin	2.8 - 3.1
Porcelain	4.4 - 7
Press board	2 - 5
Propane, liquid	1.6
Propylene, liquid	11.9
Quartz glass	3.7
Rice, dry	3.5

Material	Dielectric Constant
Rubber	2.5 - 35
Salt	6.0
Sand	3 - 5
Shellac	2.0 - 3.8
Silicon dioxide	4.5
Silicone rubber	3.2 - 9.8
Silicone varnish	2.8 - 3.3
Soybean	2.8
Styrene resin	2.3 - 3.4
Sugar	3.0
Sugar, granulated	1.5 - 2.2
Sulfur	3.4
Sulfuric acid	84
PCTFE	2.3 - 2.8
PTFE	2.0
Toluene	2.3
Trichloroethylene	3.4
Urea resin	6.2 - 9.5
Urethane	3.2
Vaseline	2.2 - 2.9
Vinyl Chloride	2.8
Water	48 - 88
Wax	2.4 - 6.5
Wood, dry	2 - 7
Wood, pressed board	2.0 - 2.6
Wood, wet	10 - 30
Xylene	2.4
Zinc Oxide	1.7
Zirconium Oxide	12.5
Zirconium Silicate	5.0

CAPACITIVE

R16 LEVEL SENSORS PRODUCT OVERVIEW

WHAT IS AN *EZ-track*® LIQUID LEVEL PROBE?

The *EZ-track* R16 liquid level probe is a programmable, two-wire loop powered intrinsically safe probe that is ideal for continuous level monitoring in a variety of liquids and tank designs. The R16 sensor uses magnetostrictive technology to monitor the position of a magnetic float along the active stroke of the sensing tube, which is then converted into a configurable 4-20 mA output.

All of the electronics for the R16 sensor are incorporated within the 5/8 inch sensing rod, which eliminates the need for an electronics enclosure at the top of the sensor. This feature, when ordered with the standard 4-pin *minifast*® 7/8-16UN quick disconnect, offers greater mounting options, and a faster, more reliable installation.

WHY CHOOSE THE *EZ-track* LIQUID LEVEL PROBE?

- IP68 rated; available in a rigid 316 stainless steel housing or a flexible PVDF design.
- Probe lengths vary between 18 and 288 inches.
- A variety of floats, fittings and accessories are available to fit virtually any application requirement.
- A resolution of 0.02 inches of full scale, and an accuracy of 0.1% over the programmable monitoring span.

WHERE CAN I USE THE *EZ-track* LIQUID LEVEL PROBE?

- Because there are no parts to wear or break, the sensors offer better performance than competing technologies.
- The stainless steel version is also available in an optional Food Grade or 3A Rated Sanitary finish probe for use in an array of food service, dairy and beverage applications.



Level Sensors - R16 Probe

R16 Level Probe Part Number Key

LT E - R 16 - LI - EX - / 3A

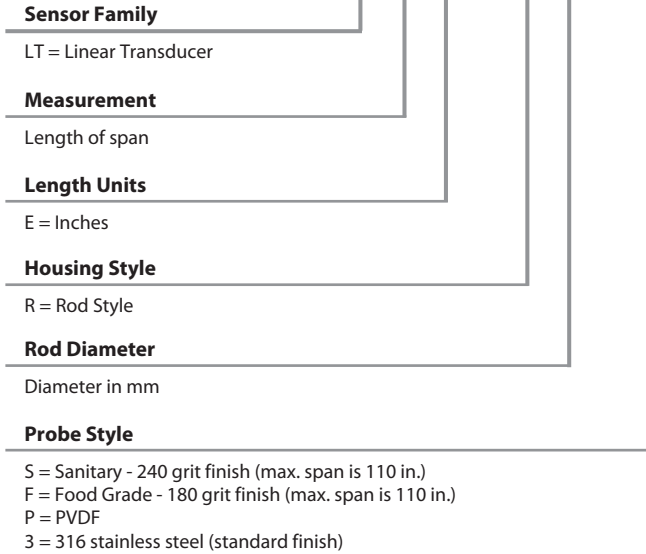

Special Approvals
3A = 3A approved sensor with float³

Connector Type
D = Dual 3/4 inch NPT
B1140 = 4-pin, *minifast*⁴
S = Single 3/4 in. NPT (steel)
Single 1/2 in. NPT² (PVDF, with flange "C" only)

Intrinsically Safe
EX
* must be connected to appropriate barrier

Output Type (Bottom to Top)
0 = 4 to 20 mA
1 = 20 to 4 mA

Output Configuration
LI = Current

Flange Adapter
Blank = No Adapter¹
20 = 2 inch Tri-clamp⁴
25 = 2.5 inch Clamp⁴
30 = 3 inch Tri-clamp⁴
40 = 4 inch Tri-clamp⁴
C = 3 inch Dead Band², temperature limited (0 to 40 C)

- Note:**
1. Available on probe styles 3 or P only.
 2. Available on probe styles P only.
 3. Available on probe styles S only.
 4. Not available on probe style P.

R16 LEVEL

Specifications

Stainless Steel Probe	
Output	4 to 20 mA, 20 to 4 mA
Span	8 to 278 inches
Repeatability	0.014 in. + 0.5% of programmable span typical; max 0.014 in. + 0.4% of span
Resolution	0.025% of programmable span / 0.02 in., whichever is greater
Operating Temperature	-20°C to +70°C (-4°F to +158°F)
Null Zone	8 in.
Dead Zone	2 in.
Operational Voltage	13.5 to 30 VDC
Current Consumption	Loop Powered
Enclosure Rating	IP68
Accuracy	0.1% of programmable span or 0.050 in.
Reading Rate	40 ms
Rod Diameter	0.625 in. (15.9 mm)
Pressure	1015 psi
Electronics	Stainless Steel 316L
Rod	Stainless Steel 316L
Agency Approvals	FM
FM Approval	Class I, Div 1, Group C and D Class II, Div 1, Group E, F, and G Class I, Zone 0 or 1, Groups IIA or IIB

PVDF Probe	
Output	4 to 20 mA, 20 to 4 mA
Span	7 to 268 in.
Repeatability	0.014 in. + 0.5% of programmable span typical; max 0.014 in. + 0.4% of programmable span
Resolution	0.025% of programmable span or 0.02 in., whichever is greater
Operating Temperature	-20°C to +70°C (-4°F to +158°F)
Null Zone	12 in. (9 in. for flange adapter "C")
Dead Zone	6 to 8 in. (span 7 in. to 126 in.: 6 in.; span 127 in. to 268 in.: 8 in.) 3 in. For flange adapter "C"
Operational Voltage	13.5-30 VDC
Current Consumption	Loop Powered
Enclosure Rating	IP68
Accuracy	0.1% of programmable span
Reading Rate	40 ms
Rod Diameter	0.625 in. (15.9 mm)
Pressure	145 psi
Electronics	PVDF
Rod	PVDF
Agency Approvals	FM
FM Approval	Class I, Div 1, Group C and D Class II, Div 1, Group E, F, and G Class I, Zone 0 or 1, Groups IIA or IIB

TURCK

Level Sensors - R16 Probe



Housing Style	Part Number	Output Current
Stainless Steel Level Probe, minifast[®] Connection 	LT***E-R16-3LI0-EX-B1140	4-20 mA Loop Powered
	LT***E-R16-3LI1-EX-B1140	20-4 mA Loop Powered
Stainless Steel Level Probe, Dual 3/4 NPT Connection 	LT***E-R16-3LI0-EX-D	4-20 mA Loop Powered
	LT***E-R16-3LI1-EX-D	20-4 mA Loop Powered
Stainless Steel Level Probe, Single 3/4 NPT Connection 	LT***E-R16-3LI0-EX-S	4-20 mA Loop Powered
	LT***E-R16-3LI1-EX-S	20-4 mA Loop Powered
Stainless Steel Level Probe, minifast Connection, Tri-clamp Adapter 	LT***E-R16-3**LI0-EX-B1140	4-20 mA Loop Powered
	LT***E-R16-S**LI0-EX-B1140	
	LT***E-R16-F**LI0-EX-B1140	
Stainless Steel Level Probe, Single 3/4 NPT Connection, Tri-clamp Adapter 	LT***E-R16-3**LI1-EX-B1140	20-4 mA Loop Powered
	LT***E-R16-S**LI1-EX-B1140	
	LT***E-R16-F**LI1-EX-B1140	
Stainless Steel Level Probe, Single 3/4 NPT Connection, Tri-clamp Adapter 	LT***E-R16-3**LI0-EX-S	4-20 mA Loop Powered
	LT***E-R16-3**LI1-EX-S	20-4 mA Loop Powered

* Float ordered separately, see page E54.

** For flange dimensions, see page E53.

Level Sensors - R16 Probe

Voltage	Probe Style (Finish)	Operating Temp. (°C)	Pressure Rating (psi)	Connection Type	Agency Approval	Mating Cord, Cable Length/ Jacket	Wiring Diagram #	Wiring Diagrams
13.5-30 VDC	316 Stainless Steel	-20 to 70	1015	4-pin <i>minifast</i>	FM	RKM 46-*M	1	<p>Diagram 1</p> <p>Diagram 2</p>
	316 Stainless Steel	-20 to 70	1015	4-pin <i>minifast</i>	FM	RKM 46-*M	1	
13.5-30 VDC	316 Stainless Steel	-20 to 70	1015	Dual 3/4 NPT	FM	2 ft./PVC	2	
	316 Stainless Steel	-20 to 70	1015	Dual 3/4 NPT	FM	2 ft./PVC	2	
13.5-30 VDC	316 Stainless Steel	-20 to 70	1015	Single 3/4 NPT	FM	2 ft./PVC	2	
	316 Stainless Steel	-20 to 70	1015	Single 3/4 NPT	FM	2 ft./PVC	2	
13.5-30 VDC	316 Stainless Steel	-20 to 70	1015	4-pin <i>minifast</i>	FM	RKV 46-*M	1	
	Sanitary (316 SS w/240 grit)	-20 to 70	1015	4-pin <i>minifast</i>	FM	RKV 46-*M	1	
	Food Grade (316 SS w/180 grit)	-20 to 70	1015	4-pin <i>minifast</i>	FM	RKV 46-*M	1	
	316 Stainless Steel	-20 to 70	1015	4-pin <i>minifast</i>	FM	RKV 46-*M	1	
	Sanitary (316 SS w/240 grit)	-20 to 70	1015	4-pin <i>minifast</i>	FM	RKV 46-*M	1	
	Food Grade (316 SS w/180 grit)	-20 to 70	1015	4-pin <i>minifast</i>	FM	RKV 46-*M	1	
13.5-30 VDC	316 Stainless Steel	-20 to 70	1015	Single 3/4 NPT	FM	2 ft./PVC	2	
	316 Stainless Steel	-20 to 70	1015	Single 3/4 NPT	FM	2 ft./PVC	2	

R16 LEVEL

* Length in meters.

TURCK

Level Sensors - R16 Probe



Housing Style	Part Number	Output
<p>Stainless Steel Level Probe, <i>minifast</i>® Connection, Tri-clamp Adapter, with Float</p> <p>FM APPROVED</p>	<p>LT***E-R16-S**LI0-EX-B1140/3A</p>	<p>4-20 mA Loop Powered</p>
<p>PVDF Level Probe, Dual 3/4 NPT Connection</p> <p>FM APPROVED</p>	<p>LT***E-R16-PLI0-EX-D</p>	<p>4-20 mA Loop Powered</p>
<p>PVDF Level Probe, Single 1/2 NPT Connection, Temperature Limited</p> <p>FM APPROVED</p>	<p>LT***E-R16-PLI1-EX-D</p>	<p>20-4 mA Loop Powered</p>
<p>PVDF Level Probe, Single 1/2 NPT Connection, Temperature Limited</p> <p>FM APPROVED</p>	<p>LT***E-R16-PCLI0-EX-S</p>	<p>4-20 mA Loop Powered</p>
<p>PVDF Level Probe, Single 1/2 NPT Connection, Temperature Limited</p> <p>FM APPROVED</p>	<p>LT***E-R16-PCLI1-EX-S</p>	<p>20-4 mA Loop Powered</p>

* Float ordered separately, see page E54.
 ** For flange dimensions, see page E53.

Level Sensors - R16 Probe

Voltage	Probe Style (Finish)	Operating Temp. (°C)	Pressure Rating (psi)	Connection Type	Agency Approval	Mating Cord, Cable Length/ Jacket	Wiring Diagram #	Wiring Diagrams
13.5-30 VDC	Sanitary (316 SS w/240 grit)	-20 to 70	1015	4-pin <i>minifast</i>	3A, FM	RKV 46-*M	1	<p>Diagram 1</p> <p>Diagram 2</p>
	Sanitary (316 SS w/240 grit)	-20 to 70	1015	4-pin <i>minifast</i>	3A, FM	RKV 46-*M	1	
13.5-30 VDC	PVDF	-20 to 70	145	Dual 3/4 NPT	FM	2 ft./PVC	2	<p>Diagram 2</p>
	PVDF	-20 to 70	145	Dual 3/4 NPT	FM	2 ft./PVC	2	
13.5-30 VDC	PVDF	0 to 40	145	Single 1/2 NPT	FM	2 ft./PVC	2	<p>Diagram 2</p>
	PVDF	0 to 40	145	Single 1/2 NPT	FM	2 ft./PVC	2	

* Length in meters.

R16 LEVEL

TURCK

Level Sensors - R16 Probe

All dimensions shown as: Inches [mm]

Flange Options

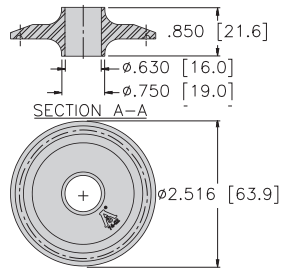

Flange, 2 inch Tri-clamp

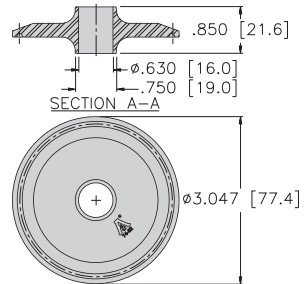

Flange, 2.5 inch Tri-clamp

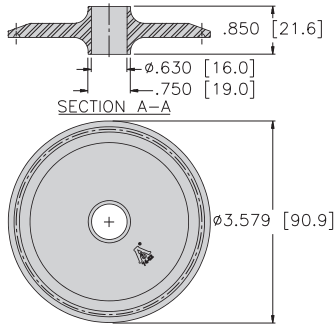

Flange, 3 inch Tri-clamp

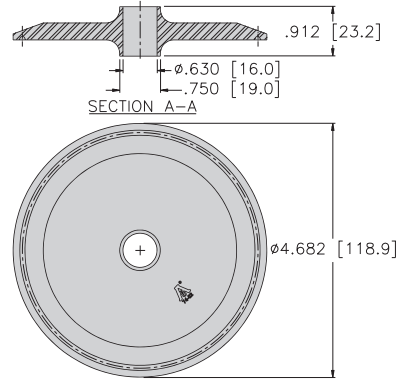

Flange, 4 inch Tri-clamp

Level Probe Accessories

Tube Coupling

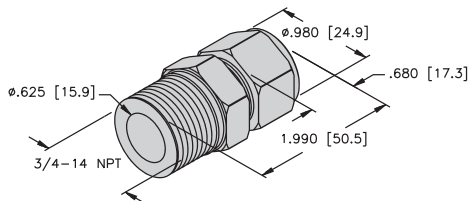

TC-R16-SS
(LT0305)

Junction Box

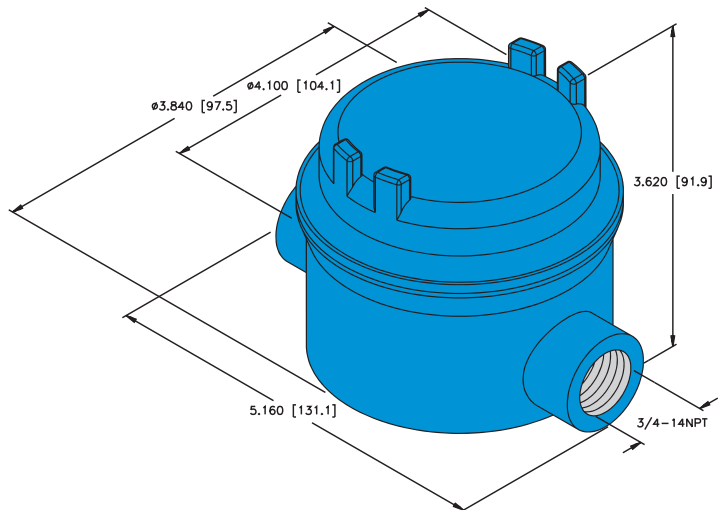

TB-R16S
(LT0294)

Level Sensors - R16 Probe

Level Probe Accessories

Bushing (316 Stainless Steel)

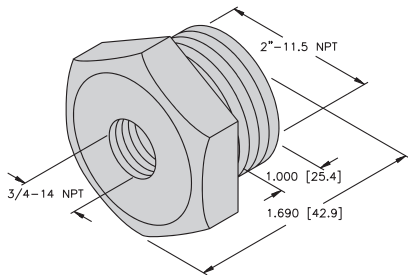

BU-R16-2x3/4 NPT-SS (LT0306)

Float Kit (316 Stainless Steel)
General Applications

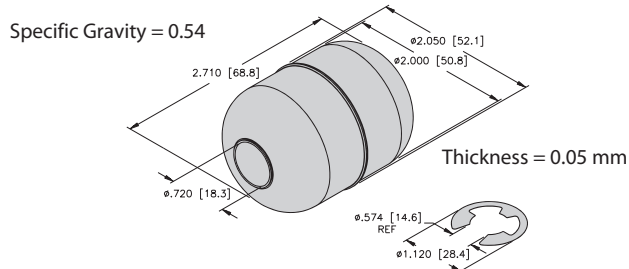

FK-R16-205-SSES (LT0299)

Float Kit (316 Stainless Steel)
General Applications

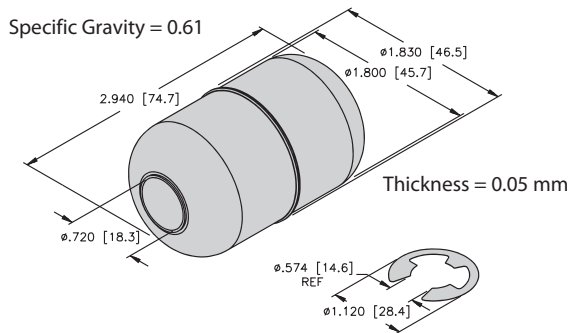

FK-R16-183-SSES (LT0296)

Float Kit (316 Polished Stainless Steel)
Food Grade and Sanitary Applications

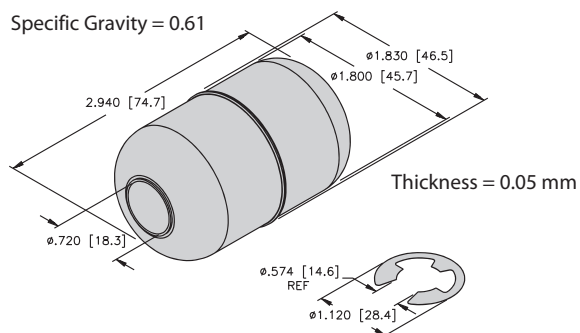

FK-R16-183-SSE (LT0302)

Probe Foot (ECTFE)

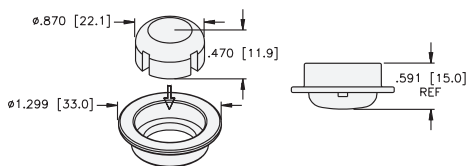

PF-R16 (LT0292)

Weight Kit (316 Stainless Steel)

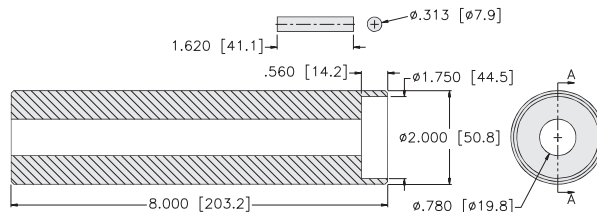

WK-R16 (LT0295)

Required on PVDF probes up to 288 inches long.

R16 LEVEL

TURCK

Level Sensors - R16 Probe

R16 Level Probe Worksheet

Liquid to be measured _____

Fluid Properties (check all that apply)

___ Turbulent

___ Foam

___ Solids

Product Build-Up Yes ___ No ___

Temperature Range _____°F to _____°F

Pressure Range _____ to _____

Viscosity Range _____ to _____

Specific Gravity _____

4 mA Starting Point Top ___ Bottom ___

Approvals Required

UL ___ CSA ___ FM ___ 3A ___ Food Grade ___

Tank Location Indoors ___ Outdoors ___

Tank Material _____

Additional Comments _____

**Allow overhead clearance for installation and removal of sensor.*

Customer

Phone Number

Date

Project

Quantity

Level Sensors - R16 Probe

R16 Level Probe Worksheet

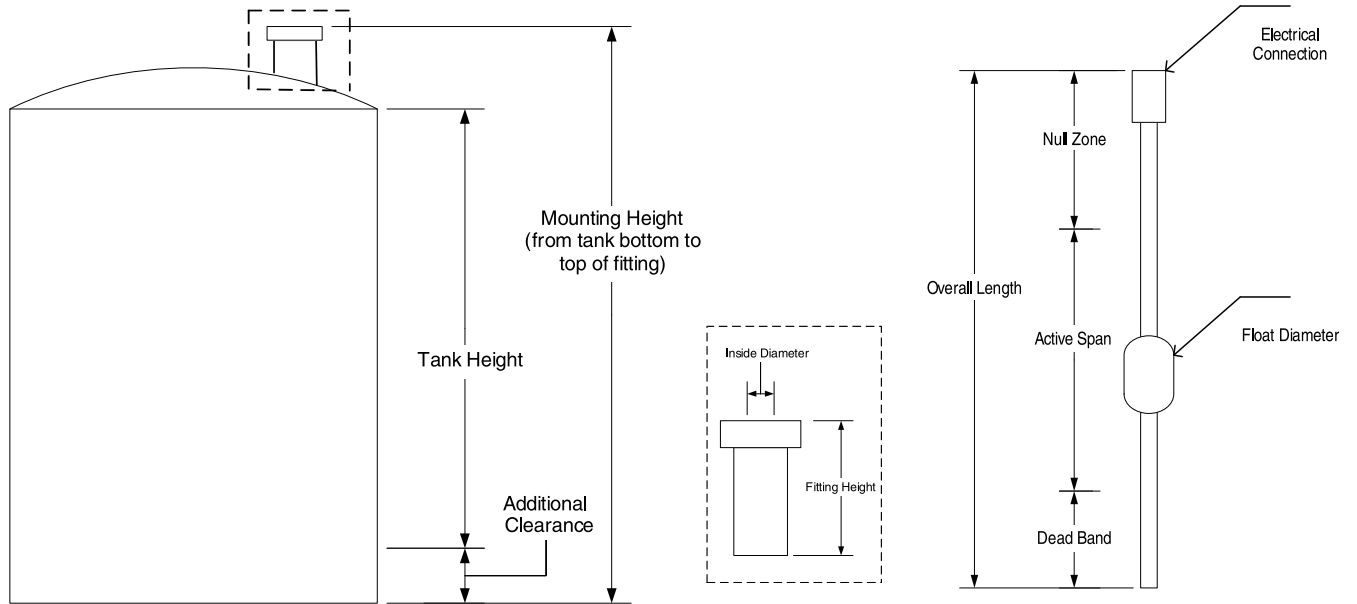

R16 LEVEL

ANALOG AND LEVEL CONVERTERS PRODUCT OVERVIEW

WHAT ARE ANALOG AND LEVEL CONVERTERS?

Since analog measurement is common in hazardous areas, TURCK's IM33 and IM43 analog converting device may be used to convert a 2, 3 or 4-wire signals in a hazardous area to an analog 4-20 mA signal in a non-hazardous area.



WHY CHOOSE ANALOG AND LEVEL CONVERTERS?

- Several different inputs may be configured and used with common 4-20 mA analog input control cards.
- Consolidate inventory by eliminating separate analog input cards.
- Use of off-the-shelf "Simple Apparatus" components in explosive atmospheres to further reduce installation costs.
- Push button, rotary switch or software (FDT/DTM, free shareware) configurable units are simple to use.

WHERE CAN I USE ANALOG AND TEMPERATURE CONVERTERS?

- Hazardous areas

Analog and Level Converters Selection Guide

Part Number	Configuration	Input 0/4-20mA	Output Relay	Output 0/4-20mA	Display
IM33-11EX-HI	N/A	1	No	1	No
IM33-12EX-HI	N/A	1	No	2	No
IM33-22EX-HI	N/A	2	No	2	No
IM33-14EX-CDRI	Pushbuttons or PACTware	1	2 Relay 1 Transistor	1	Yes

Part Number	Configuration	Input 0/2-10V or 0/4-20mA	Output Relay	Output 0/4-20mA	Display
IM43-13-R	Rotary switch	1	3	No	No
IM43-14-RI	Rotary switch	1	3	1	No
IM43-13-SR	Pushbuttons	1	3	No	No
IM43-14-SRI	Pushbuttons	1	3	1	No
IM43-14-CDRI	Pushbuttons or PACTware	1	3	1	Yes

ANALOG AND LEVEL CONVERTERS PRODUCT OVERVIEW



The IM43-14-CDRI and similar IM modules can be programmed using PACTware and their relevant DTM. Programming is quick and simple and allows for greater parameters to be set. Configurations can be saved on a PC and downloaded to other units at a later date. In this example, the IM43 is connected to an Inductive analog proximity sensor by a RK 4.4T cordset and is providing analog feedback. The IM43 display can be user defined from numerous choices and provides 3 relay set points and a 0/4 to 20mA output.

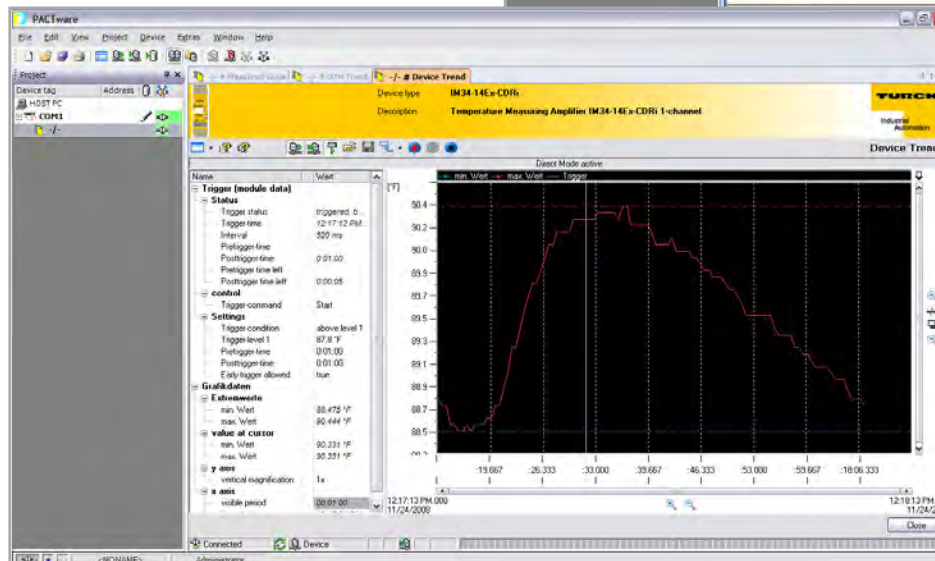
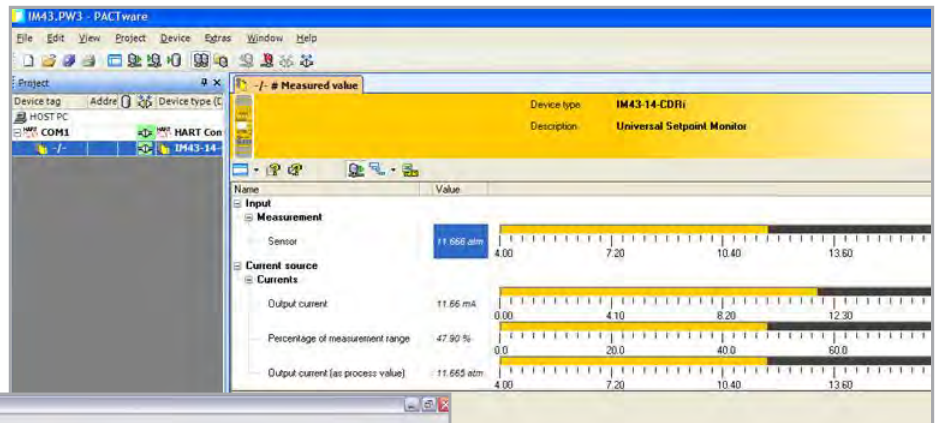

The ability to trend data using PACTware aids in monitoring processes, start-up, commissioning and troubleshooting. Call your local TURCK representative for a full demonstration.

CONDUCTIVE ROD LEVEL SENSORS PRODUCT OVERVIEW

WHAT ARE ROD LEVEL SENSORS AND CONTROLLERS?

TURCK liquid level probes may be used in conjunction with TURCK level control monitors, to provide a simple solution for liquid level applications. The resistance between the terminals is measured to determine the level of the medium in the tank.

TURCK also offers stainless steel probes and stainless steel holders with ceramic insulators. The probes are used to provide single-point level control, while the holders are sealed to withstand applications up to 2500 psi at 70° F (21°C).

WHY CHOOSE ROD LEVEL SENSORS AND CONTROLLERS?

- Adjustable sensitivity
- Single set-points
- Multiple inputs
- On/off delay
- Programmable outputs

WHERE CAN I USE ROD LEVEL SENSORS AND CONTROLLERS?

- To control the filling and draining of a tank, or as high and low level alarms.
- To differentiate between a variety of liquids, as well as distinguishing between liquid and foam.
- To set an adjustable on and off-delay for use in turbulent liquid level applications.
- To control overflow monitoring.



Level Detection Application Examples

Control for Pump-in "Filling" a Tank

The MK91-12-R will start a pump or open a fill valve when the liquid drops below the MIN level probe and will remain on until the MAX level probe is reached. The relay then de-energizes and stays off until the MIN level is reached. The pump or valve does not cycle constantly, as would be the case if only one sensor were used.

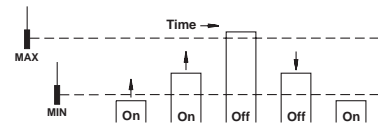
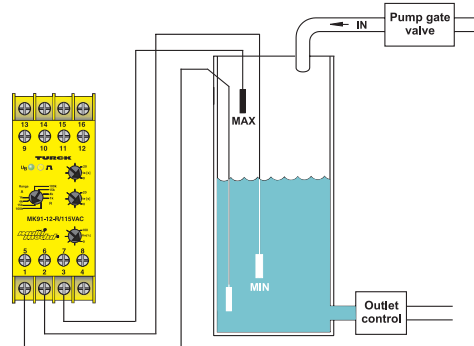

Example Application using MK91-12-R/...

Control for Pump-out "Draining" a Tank

The MK91-12-R will start a pump when the liquid reaches the MAX level probe and remain on until the MIN level probe is reached. The relay then de-energizes and stays off until the MAX level is reached. The pump or valve does not cycle constantly, as would be the case if only one sensor were used.

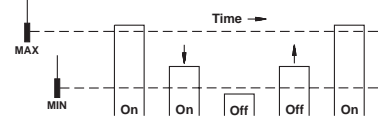
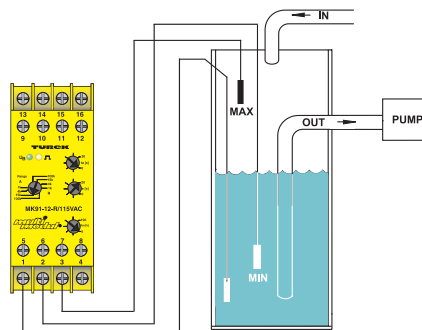

Example Application using MK91-12-R/...

Level Sensors - Conductive Rods

MK91-121-R.. and MK91-12-R..	
Galvanic Isolation	between input, output and supply circuits, test voltage 2.5 kVrms
Probe Voltage	0.02-5 V _{pp} /150 Hz (delta)
Sensitivity Ranges (Switching Thresholds)	
- Range 1	0.2-1 k
- Range 2	0.8-4 k
- Range 3	2.5-15 k
- Range 4	10-100 k
Hysteresis	approx. 10%
Switch-on Delay	0-20 s (adj.)
Switch-off Delay	0-20 s (adj.)
Contact Material	silver alloy + 3 Au
Switching Capacity	500 VA / 60 W
Protection	IP20
Mounting	DIN 50022 or pull-out tabs
Operating Temperature	-25°C to +60°C (-13°F to +140°F)
Line Frequency (AC)	48-62 Hz
Ripple (DC)	10%

MS91-12-R..	
Galvanic Isolation	between input, output and supply circuits
Probe Voltage	typ. 5 V _{pp} /100 Hz (delta)
Sensitivity Ranges (Switching Thresholds)	
- Range 1	0.1-1 k
- Range 2	0.5-5 k
- Range 3	2-20 k
- Range 4	10-100 k
Hysteresis	10%
Switch-on /Switch-off Delay	0.1-15 s (adj.)
Contact Material	AgCdO
Switching Capacity	500 Va/60 W
Protection	IP20
Mounting	DIN 50022 or pull-out tabs
Operating Temperature	-25°C to +60°C (-13°F to +140°F)
Line Frequency (AC)	48-62 Hz
Ripple (DC)	10%

MK91-R11..	
Galvanic Isolation	between input and output circuit, insulation test voltage 4 kV/8 mm input circuit and supply voltage galvanically connected
Switching Point Deviation in Supply Voltage Range	1%
Operating Characteristics at:	V = 24 V, R _M = 40 k
- Rectangular Signal	f = 1 Hz
- Amplitude of Electrode Voltage	≥2 V
- Amplitude of electrode current	≥50 A
Contact Material	silver alloy + 3 Au
Switching Capacity	500 VA / 60 W
Protection	IP20
Mounting	DIN 50022 or pull-out tabs
Operating Temperature	-25°C to +60°C (-13°F to +140°F)
Line Frequency (AC)	48-62 Hz
Ripple (DC)	10%

TURCK

Level Sensors - Conductive Rods



Housing Style	Part Number	ID Number	Temp. & Pressure Ratings	Number of Probes	Maximum Pressure (psi)	Fluid Connection
<p>Probe Holder</p>	WCC-1138	A3365	2500 psi @ 120°F 250 psi @ 406°F	1	2500	Dryseal 3/8-18UNC PTF-SAE Short thread
<p>Probe Holder</p>	WCT-2	A3375	250 psi @ 406°F 2500 psi @ 120°F	2	2500	Dryseal 1-11 1/2 UNC PTF-SAE Short thread

Material

Probe Holders	303/304 Stainless Steel
Insulators	Ceramic
Probes	304 Stainless Steel

Level Sensors - Conductive Rods

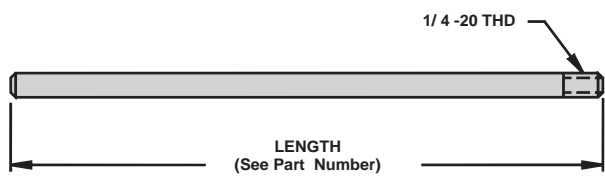
Housing Style	Part Number	ID Number	Material
Stainless Steel Probes 	91-SSP 01 Ft	A3000	304 Stainless Steel
	91-SSP 02 Ft	A3002	304 Stainless Steel
	91-SSP 03 Ft	A3004	304 Stainless Steel
	91-SSP 04 Ft	A3006	304 Stainless Steel
	91-SSP 05 Ft	A3008	304 Stainless Steel
	91-SSP 06 Ft	A3010	304 Stainless Steel
	91-SSP 07 Ft	A3014	304 Stainless Steel
	91-SSP 08 Ft	A3016	304 Stainless Steel
	91-SSP 09 Ft	A3018	304 Stainless Steel
	91-SSP 10 Ft	A3020	304 Stainless Steel

For use with Amplifiers on pages E63.

TURCK

Level Sensors - Conductive Rods

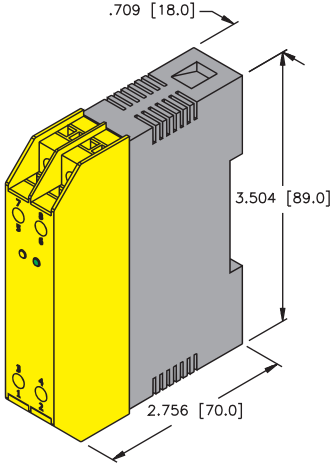
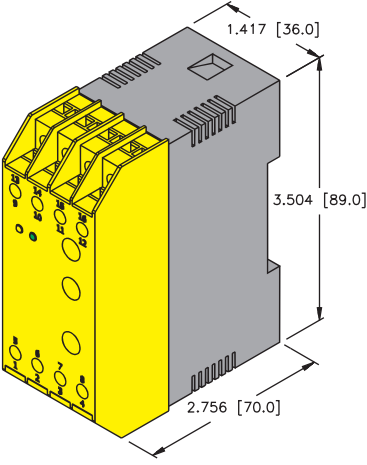

Housing Style	Part Number	ID Number	Features	Output
Level Control Monitor with Fixed Switch Point 	MK 91-R11/24VDC	M7525202	Single Level Controller 10 second delay	(1) SPDT Relay
Level Control Monitor, Potentiometer/Jumper Programmable 	MK 91-121-R/24VDC	M7545087	Dual Level Controller, Adjustable Delay	(2) SPDT Relays/Parallel

Material

Housing	PC/ABS
---------	--------

Level Sensors - Conductive Rods

Voltage	Switching Current	Switch Point	Current Consumption	Hysteresis	Power LED	Output LED	Wiring Diagram #	Wiring Diagrams
19-29 VDC	3 A at 250 VUC	40 k Fixed	20 mA at 24 VDC	Approx. 5%	GN	YE	1	<p>Diagram 1</p> <p>Diagram 2</p>
20-28 VDC	3 A at 250 VUC	0.2-100 k	1.5 W	Approx. 10%	GN	YE	2	
184-264 VAC	3 A at 250 VUC	0.2-100 k	3 VA/<15 mARMS	Approx. 10%	GN	YE	2	

CONDUCTIVE RODS

TURCK

Level Sensors - Conductive Rods

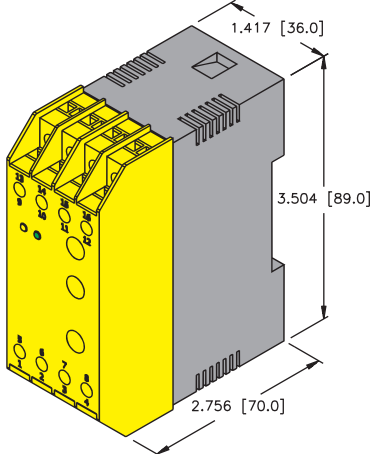
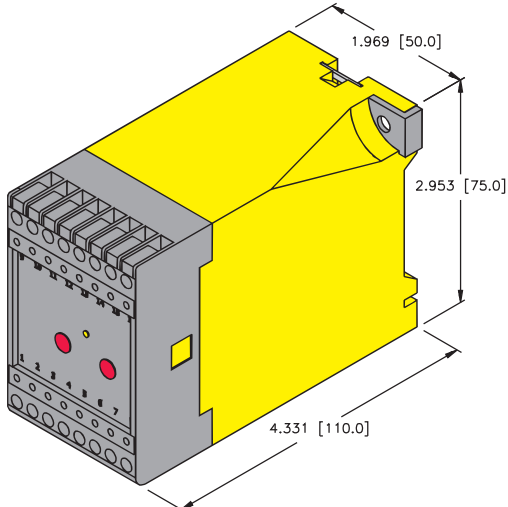

Housing Style	Part Number	ID Number	Features	Output
Level Control Monitor 24 VDC, Dip-Switch Programmable 	MK 91-12-R/024VDC	M7545077	Dual Level Controller, Adjustable Time Delay	(2) SPDT Relays/Parallel
	MK 91-12-R/115VAC	M7545072		
	MK 91-12-R/230VAC	M7545070		
Level Control Monitor, Potentiometer/Jumper Programmable 	MS91-12-R	M5220110	Dual Level Controller, Adjustable Time Delay	(2) SPDT Relays/Parallel

Material

Housing	PC/ABS
---------	--------

Level Sensors - Conductive Rods

Voltage	Switching Current	Switch Point	Current Consumption	Hysteresis	Power LED	Output LED	Wiring Diagram #	Wiring Diagrams
20-28 VDC	3 A at 250 VUC	0.2-100 k	1.5 W	Approx. 10%	GN	YE	1	<div style="border: 1px solid black; padding: 5px;"> <p style="text-align: center; background-color: #ADD8E6; margin: 0;">Diagram 1</p> </div> <div style="border: 1px solid black; padding: 5px; margin-top: 10px;"> <p style="text-align: center; background-color: #008000; color: white; margin: 0;">Diagram 2</p> </div>
98-126 VAC	3 A at 250 VUC	0.2-100 k	3 VA/<15 mARMS	Approx. 10%	GN	YE	1	
184-264 VAC	3 A at 250 VUC	0.2-100 k	3 VA/<15 mARMS	Approx. 10%	GN	YE	1	
20-250 VUC	4 A at 250 VUC	0.1-100 k	3 W	Approx. 10%	GN	YE	2	

CONDUCTIVE RODS

VALVE SENSORS SELECTION GUIDE

Housing	Style	Features	Applications	Page
	DSU35 Valve Sensors	<ul style="list-style-type: none"> ■ Outputs: PNP, NPN, ASi, DeviceNet, NAMUR, AC/DC ■ Solenoid power pass through ■ 35 mm contoured housing ■ Terminal chamber housing 	<ul style="list-style-type: none"> ■ Quarter turn valves ■ Food and beverage ■ Semiconductor ■ Pharmaceutical 	F7
	DSU26 and DSC26 Valve Sensors	<ul style="list-style-type: none"> ■ Outputs: AC/DC, PNP, ASi, NAMUR ■ 26 mm housing ■ Solenoid power pass through 	<ul style="list-style-type: none"> ■ Quarter turn valves ■ Large stem valves ■ Food and beverage ■ Semiconductor ■ Pharmaceutical 	F13
	DS20 Valve Sensors	<ul style="list-style-type: none"> ■ Outputs: PNP, NAMUR, AC/DC ■ 20 mm Housing 	<ul style="list-style-type: none"> ■ Quarter turn valves ■ Semiconductor ■ Pharmaceutical 	F15
	Vprox	<ul style="list-style-type: none"> ■ Stainless Steel housing ■ Green Power LED ■ Red Switching LEDs ■ 2 wire AC/DC 	<ul style="list-style-type: none"> ■ Rising stem valves 	F17
	Pucks	<ul style="list-style-type: none"> ■ Adjustable or Non-Adjustable ■ Varying heights for 20 or 30 mm stems ■ NAMUR puck (EU1) 	<ul style="list-style-type: none"> ■ For use with: DSU35 sensors ■ DSU26 sensors ■ DSC26 sensors ■ DS20 sensors 	F19
	Mounting Kits	<ul style="list-style-type: none"> ■ Variety of sizes ■ Works with DSU35 pucks 	<ul style="list-style-type: none"> ■ Large valve stems ■ Valve stems with collars 	F24
	Guards	<ul style="list-style-type: none"> ■ Stainless Steel Guards ■ Fits over sensor 	<ul style="list-style-type: none"> ■ Class I, Div 2 applications ■ Harsh duty applications 	F25

VALVE SENSORS PRODUCT OVERVIEW

WHAT IS A TURCK VALVE POSITION SENSOR?

TURCK's dual sensors reduce installation costs and minimize the cost of maintenance. These robust and impact resistant sensors are ideal when valve position information must be provided.

WHY CHOOSE A TURCK VALVE POSITION SENSOR?

- A variety of standard *euromast*®, *microfast*®, and *minifast*® connections available.
- The DSU35 is available with numerous outputs circuits such as a 2-wire DC, 2-wire NAMUR, 2-wire AC/DC, as well as DeviceNet™ and AS-I bus protocols.
- Solenoid power pass through allows one home run cable to run to the valve sensor and a short extension to run to the solenoid valve, reducing cable costs.

WHERE CAN I USE A TURCK VALVE POSITION SENSOR?

- **Chemical and Petrochemical Industries:** the DSU35 valve sensor and target puck are highly resistant to harsh chemicals, and may be mounted to several different actuator sizes without the need for adapters or spacer plates. The DSU35 is available with a terminal chamber, which is often required in chemical process applications where conduit must be used.
- **Food and Beverage Industries:** the DSC26 sensor uses injection-molding technology to ensure that it is fully sealed and well suited for use in wet applications. It is resistant to high pressure cleaning with aggressive cleaning agents.

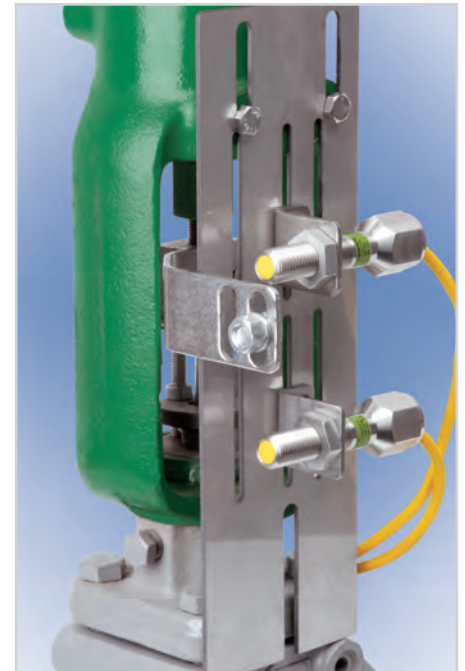

Rising stem valve shown
with TURCK Vprox® 773 sensor



TURCK

Valve Sensors

Valve Position Sensor Part Number Key

Part Number Keys are to assist in IDENTIFICATION ONLY. Consult factory for catalog items not identified.

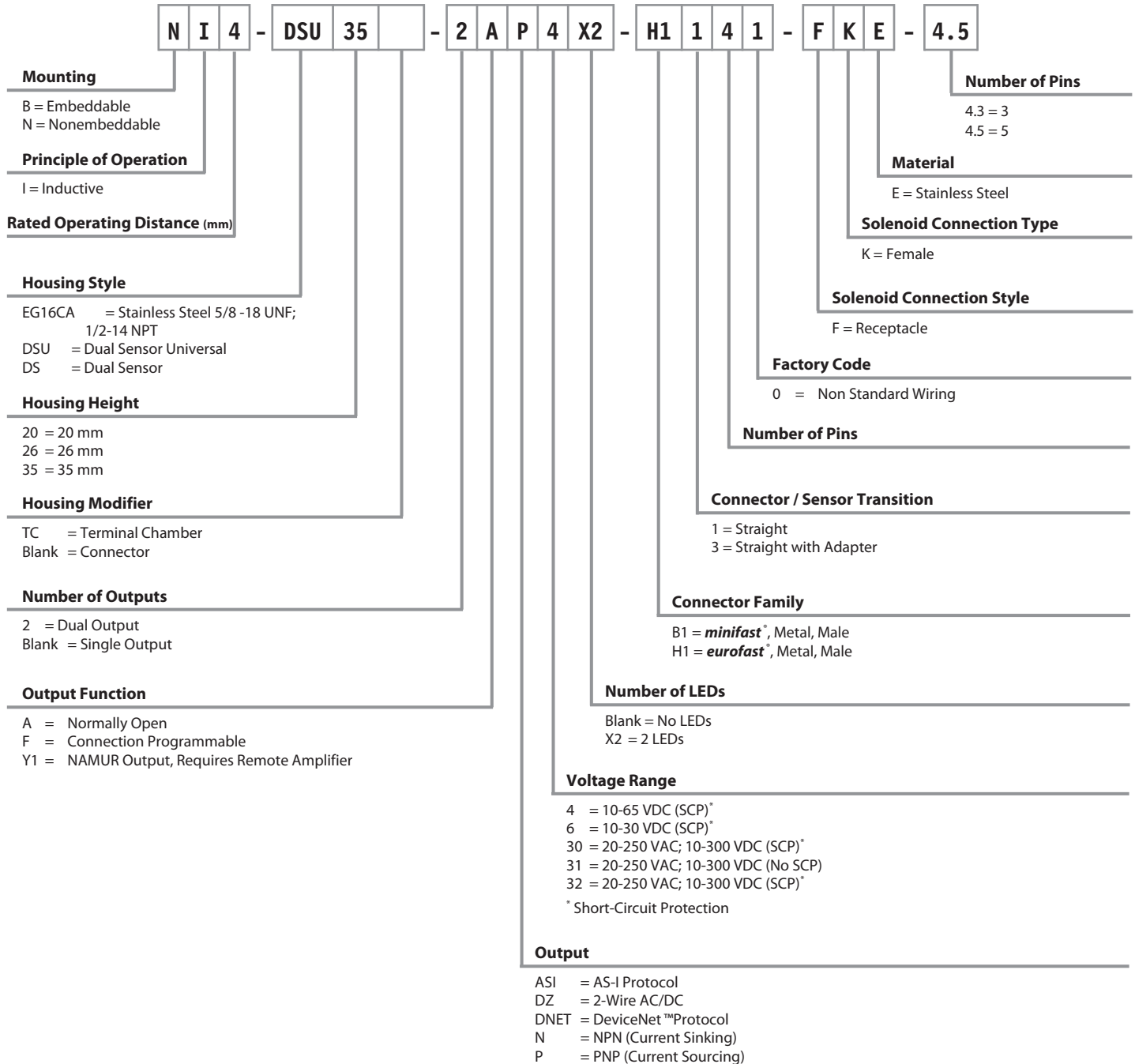

Specifications

Dual DC NAMUR – Y1	
Temperature Drift	≥10%
Differential Travel (Hysteresis)	1-10% (5% typical)
Nominal Voltage	8.2 VDC (EN60947-5-6)
Resistance Change from	
Nonactivated to Activated Condition	Typical <1.0 to >8.0 k
Rated Insulation Voltage	1.5 kV
Resulting Current Change	2.2 mA to 1.0 mA
Recommended Switching Point for	
Remote Amplifier	>1.2 to <2.1 mA, typ. 1.55 mA ON/1.75 mA OFF
Power-On Effect	Realized in Amplifier
Reverse Polarity Protection	Yes, up to 10 VDC
Wire-Break Protection	Realized in Amplifier
Transient Protection	Realized in Amplifier
Shock	30 g, 11 ms
Vibration	55 Hz, 1 mm Amplitude in all 3 Planes
Repeatability	2% of Rated Operating Distance
Short-Circuit Protection	Yes, when connected to NAMUR amplifier up to 15 VDC

Dual AC/DC without Short-Circuit Protection – ADZ31, ADZ35	
Temperature Drift	≥10%
Line Frequency	40-60 Hz
Differential Travel (Hysteresis)	3-15% (5% typical)
Voltage Drop Across Conducting Sensor	6.0 V at 400 mA
Off-State (Leakage) Current	1.7 mA
Minimum Load Current	5.0 mA
Inrush Current	8.0 A (10 ms, 5% Duty Cycle)
Power-On Effect	Per IEC 947-5-2
Transient Protection	Per EN 60947-5-2
Shock	30 g, 11 ms
Vibration	55 Hz, 1 mm Amplitude in all 3 Planes
Repeatability	2% of Rated Operating Distance
Short-Circuit Protection	No

VALVE

TURCK

Valve Sensors

Specifications

Dual AC/DC with Short-Circuit Protection – ADZ30, ADZ32, FDZ32

Temperature Drift	≥10%
Line Frequency	40-60 Hz
Differential Travel (Hysteresis)	3-15% (5% typical)
Voltage Drop Across Conducting Sensor	6.0 V at 400 mA; 8 & 12 mm 6.0 V at 100 mA
Trigger Current for Overload Protection	AC: 440 mA; DC: 330 mA
Rated Insulation Voltage	1.5 kV
Off-State (Leakage) Current	1.7 mA (AC) 1.5 mA (DC)
Minimum Load Current	3.0 mA
Inrush Current	4.0 A (20 ms, 10% Duty Cycle)
Power-On Effect	Per IEC 947-5-2
Transient Protection	Per EN 60947-5-2
Shock	30 g, 11 ms
Vibration	55 Hz, 1 mm Amplitude in all 3 Planes
Repeatability	2% of Rated Operating Distance
Short-Circuit Protection	Yes

Dual DC or Discrete Output – 2AP4X2, 2AP6X2, 2AN4X2, 2AN6X2

Temperature Drift	≥10%
Ripple	10%
Differential Travel (Hysteresis)	3-15% (5% typical)
Voltage Drop Across Conducting Sensor	1.8 V
Rated Insulation Voltage	0.5 kV
Trigger Current for Overload Protection	220 mA on 200 mA Load Current 170 mA on 150 mA Load Current 120 mA on 100 mA Load Current
Off-State (Leakage) Current	<100 A
No-Load Current	<10 mA
Time Delay Before Availability	8 ms
Power-On Effect	Per IEC 947-5-2
Reverse Polarity Protection	Incorporated
Wire-Break Protection	Incorporated
Transient Protection	Per EN 60947-5-2
Shock	30 g, 11 ms
Vibration	55 Hz, 1 mm Amplitude in all 3 Planes
Repeatability	2% of Rated Operating Distance
Short-Circuit Protection	Yes

Valve Sensors

Specifications

Dual DC – AS-interface °	
Temperature Drift	≥10%
Differential Travel (Hysteresis)	3-15% (5% typical)
No-Load Current	35 ma
Rated Insulation Voltage	0.5 kV
E/A Configuration (HEX) / ID-Code (HEX)	7 / F
I/O Matrix Input	0 = upper sensor S01 1 = lower sensor S02 2 = wire-break at output 3 = not used
I/O Matrix Output	0 = output "ON" 1-3 = not used
Short-Circuit Protection / Output Watchdog	Yes / Yes
Wire-Break Protection I _{out}	0.1 mA
Shock	30 g, 11 ms
Vibration	55 Hz, 1 mm Amplitude in all 3 Planes
Repeatability	2% of Rated Operating Distance
AS-I Version	AS-I V2.1

Dual DC – DeviceNet™	
Temperature Drift	≥10%
Differential Travel (Hysteresis)	3-15% (5% typical)
No-Load Current	60 ma
Rated Insulation Voltage	0.5 kV
Address (MacID)	0-63, via EDS file
Baud Rate	via EDS Date
Input Data DeviceNet	Bit 0 S01 input / Bit 1 S02 input / Bit 2 output error / Bit 7 input error / Bit 3-6, not used
Output Data DeviceNet	Bit 0 valve output / Bit 1-7, not used
Output Voltage	V+ - 3 V, PNP
Short-Circuit Protection / Output Watchdog	Yes / No
Wire-Break Protection I _{out}	0.1 mA
Shock	30 g, 11 ms
Vibration	55 Hz, 1 mm Amplitude in all 3 Planes
Repeatability	2% of Rated Operating Distance

LED	Color	State	Status
S01	YE	On	Target detected
S02	YE	On	Target detected
Out	YE	Off	Output Off
		On	Output On
ERR	RD	On	Output On/Off wirebreak detected
Status	RD/GN	Off	Sensor not powered
		GN On Steady	Sensor active and allocated by master
		GN Flashing	Sensor active and not allocated by master
		RD Flashing	Recoverable fault (open output, invalid input state, low bus voltage, I/O timeout)
		RD On Steady	Major fault (duplicate address, baud rate, bus off comm.)
		GN+RD On	Autobaud detect
		GN+RD Flashing	Power-up test

TURCK Valve Sensors

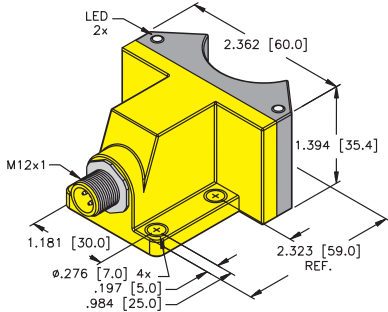
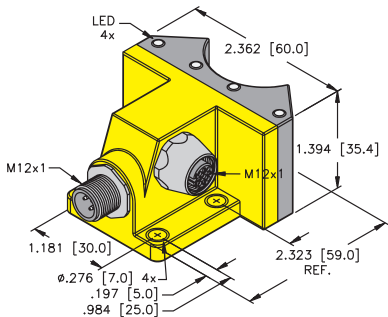

Housing Style	Part Number	ID Number	Features	Sensing Range (mm)	Output
35 mm - Nonembeddable, Dual Valve Sensor, eurofast® Connector 	Ni 4-DSU35-2AN4X2-H1141	M1569920	Short-Circuit Protection	4	Dual NPN
	Ni 4-DSU35-2AP4X2-H1141	M1569901	Short-Circuit Protection	4	Dual PNP
	Ni 4-DSU35-2Y1X2-H1140	M1051003	Short-Circuit Protection up to 15 VDC	4	Dual NAMUR
35 mm - Nonembeddable, Dual Valve Sensor, eurofast Connector 	NI 4-DSU35-2ASIX4-H1140	M1902000	Short-Circuit Protection	4	Dual ASI-BUS

Target Pucks on pages E19-E23.



Most Ni 4-DSU35... dual valve sensors are FM approved for installation in Class I, Division 2 hazardous locations. See **TURCK** control drawing Ni-1.002 (www.turck.com/fmcd) for specific models and installation requirements. Ni 4-DSU35-2Y1X2-... dual valve sensors are FM approved as intrinsically safe for installation in Class I, II or III, Division 1 hazardous locations per **TURCK** control drawing IS-1.000 (www.turck.com/fmcd).

Valve Sensors

Voltage	Switching Freq. (Hz)	Switching Current (mA) VAC/VDC	Operating Temp. (°C)	Protection	Housing	Face	Power LED	Output LED	Mating Cord, Cable Length/ Jacket	Wiring Diagram #	Wiring Diagrams
10-65 VDC	50	200	-25 to +70	IP67	PP	PP	No	YE/RD	RK 4.4T-*	1	<p>Diagram 1</p>
10-65 VDC	50	200	-25 to +70	IP67	PP	PP	No	YE/RD	RK 4.4T-*	2	<p>Diagram 2</p>
5-30 VDC	50	Remote	-25 to +70	IP67	PP	PP	No	YE/RD	RK 4.41T-*	3	<p>Diagram 3</p>
18-33 VDC	30	80	-25 to +70	IP67	PP	PP	No	YE/RD	RKC 254-*M RS 4.4T-*	4	<p>Diagram 4</p>

* Length in meters.

TURCK Valve Sensors



Housing Style	Part Number	ID Number	Features	Sensing Range (mm)	Output
35 mm - Nonembeddable, Dual Valve Sensor, minifast[®] Connector 	Ni 4-DSU35-2ADZ30X2-B1151	M4290001	Short-Circuit Protection	4	Dual AC/DC
	Ni 4-DSU35-2ADZ35X2-B1151	M4290009		4	Dual AC/DC
35 mm - Nonembeddable, Dual Valve Sensor, eurofast Connector 	Ni 4-DSU35-2ASIX4-B1140-FKE4.3	M1902009	Short-Circuit Protection	4	Dual ASI-BUS
	Ni 4-DSU35-2DNEX5-B1150-FKE4.3	M1569924	Short-Circuit Protection	4	Dual DeviceNet™
35 mm - Nonembeddable, Dual Valve Sensor, minifast Connector 	Ni 4-DSU35-2AP4X2-B1160-FKE4.5	M1569923	Short-Circuit Protection	4	Dual PNP
	Ni 4-DSU35-2ADZ30X2-B1160-FKE4.5	M4290011	Short-Circuit Protection	4	Dual AC/DC

Target Pucks on pages E19-E23.



Most Ni 4-DSU35... dual valve sensors are FM approved for installation in Class I, Division 2 hazardous locations. See **TURCK** control drawing Ni-1.002 (www.turck.com/fmcd) for specific models and installation requirements. Ni 4-DSU35-2Y1X2-... dual valve sensors are FM approved as intrinsically safe for installation in Class I, II or III, Division 1 hazardous locations per **TURCK** control drawing IS-1.000 (www.turck.com/fmcd).

Valve Sensors

Voltage	Switching Freq. (Hz)	Switching Current (mA)	Operating Temp. (°C)	Protection	Housing	Face	Power LED	Output LED	Mating Cord, Cable Length/ Jacket	Wiring Diagram #	Wiring Diagrams
20-250 VAC 10-300 VDC	30	400/300	-25 to +70	IP67	PP	PP	No	YE/RD	RKM 50-*M	1	<p>Diagram 1</p>
20-150 VAC 10-150 VDC	50	400/300	-25 to +70	IP67	PP	PP	No	YE/RD	RKM 50-*M	1	<p>Diagram 2</p>
18-33 VDC	30	80	-25 to +70	IP67	PP	PP	No	YE/RD	RKM 254-*M RS 4.4T-*	2	<p>Diagram 3</p>
11-25 VDC	50	80	-25 to +70	IP67	PP	PP	No	YE/RD	RKM 572-*M RS 4.4T-*	3	<p>Diagram 4</p>
10-65 VDC	50	200	-25 to +70	IP67	PP	PP	No	YE/RD	RKM 60-*M RS 4.5T-*	4	<p>Diagram 4</p>
20-250 VAC 10-300 VDC		400/300	-25 to +70	IP67	PP	PP	No	YE/RD	RKM 60-*M RS 4.5T-*	1	

* Length in meters.

VALVE

TURCK

Valve Sensors



Housing Style	Part Number	ID Number	Features	Sensing Range (mm)	Output
35 mm - Nonembeddable, Dual Valve Sensor, Terminal Chamber 	Ni 4-DSU35TC-2AP4X2	M1569902	Short-Circuit Protection	4	Dual PNP
	Ni 4-DSU35TC-2Y1X2	M1051004	Short-Circuit Protection up to 15 VDC	4	Dual NAMUR
	Ni 4-DSU35TC-2ADZ30X2	M4290002	Short-Circuit Protection	4	Dual AC/DC
	Ni 4-DSU35TC-2ASIX4	M1902005	Short-Circuit Protection	4	Dual ASI-BUS

Target Pucks on pages E19-E23.



Most Ni 4-DSU35... dual valve sensors are FM approved for installation in Class I, Division 2 hazardous locations. See **TURCK** control drawing Ni-1.002 (www.turck.com/fmcd) for specific models and installation requirements. Ni 4-DSU35TC-2Y1X2 dual valve sensors are FM approved as intrinsically safe for installation in Class I, II or III, Division 1 hazardous locations per **TURCK** control drawing IS-1.000 (www.turck.com/fmcd).

Valve Sensors

Voltage	Switching Freq. (Hz)	Switching Current (mA) VAC/VDC	Operating Temp. (°C)	Protection	Housing	Face	End Cap	Power LED	Output LED	Mating Cord, Cable Length/ Jacket	Wiring Diagram #	Wiring Diagrams
10-65 VDC	50	200	-25 to +70	IP67	PP	PP	N/A	N/A	YE/RD	N/A	1	<p>Diagram 1</p>
5-30 VDC	50	Remote	-25 to +70	IP67	PP	PP	N/A	N/A	YE/RD	N/A	2	<p>Diagram 2</p>
20-250 VAC 10-300 VDC	30	400/300	-25 to +70	IP67	PP	PP	N/A	N/A	YE/RD	N/A	3	<p>Diagram 3</p>
18-33 VDC	30	80	-25 to +70	IP67	PP	PP	N/A	N/A	YE/RD	N/A	4	<p>Diagram 4</p>

VALVE

TURCK

Valve Sensors

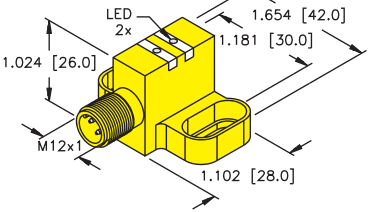
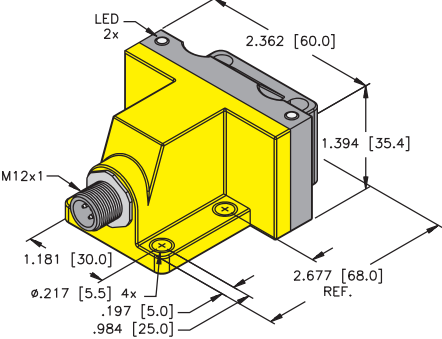
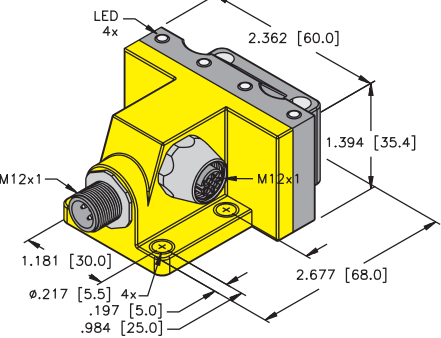

Housing Style	Part Number	ID Number	Features	Sensing Range (mm)	Output
26 mm - Nonembeddable, Dual Valve Sensor, eurofast® Connector 	Ni 4-DSC26-2AP6X2-H1141	M1650087	Short-Circuit Protection	4	Dual PNP
26 mm - Nonembeddable, Dual Valve Sensor, eurofast Connector 	Ni 4-DSU26-2AP4X2-H1141	M1569904	Short-Circuit Protection	4	Dual PNP
	Ni 4-DSU26-2Y1X2-H1140	M1051007	Short-Circuit Protection up to 15 VDC	4	Dual NAMUR
26 mm - Nonembeddable, Dual Valve Sensor, eurofast Connector 	Ni 4-DSU26-2ASIX4-H1140-FKE4.3	M1902010	Short-Circuit Protection	4	Dual ASI-BUS

Target Pucks on pages E19-E23.



Most Ni 4-DSU26-Y1X2-... dual valve sensors are FM approved as intrinsically safe for installation in Class I, Division 1 hazardous locations per **TURCK** control drawing IS-1.000 (www.turck.com/fmcd).

Valve Sensors

Voltage	Switching Freq. (Hz)	Switching Current (mA) VAC/VDC	Operating Temp. (°C)	Protection	Housing	Face	Power LED	Output LED	Mating Cord/ Cable Length/ Jacket	Wiring Diagram #	Wiring Diagrams
10-30 VDC	50	200	-25 to +70	IP67	PP	PP	No	YE/RD	RK 4.4T-*	1	<p>Diagram 1</p> <p>Diagram 2</p> <p>Diagram 3</p>
10-65 VDC	50	200	-25 to +70	IP67	PP	PP	No	YE/RD	RK 4.4T-*	1	<p>Diagram 3</p>
5-30 VDC	50	Remote	-25 to +70	IP67	PP	PP	No	YE/RD	RK 4.41T-*	2	<p>Diagram 3</p>
18-33 VDC	30	80	-25 to +70	IP67	PP	PP	No	YE/RD	RKC 254-* RS 4.4T-*	3	

* Length in meters.

VALVE

TURCK Valve Sensors



Housing Style	Part Number	ID Number	Features	Sensing Range (mm)	Output
20 mm - Nonembeddable Dual Valve Sensor eurofast® Connection 	Ni 4-DS20-2AP6X2-H1141	M1650020	Short-Circuit Protection	4	Dual PNP
	Ni 4-DS20-2Y1X2-H1140	M1050001	Short-Circuit Protection up to 15 VDC	4	Dual NAMUR
20 mm - Nonembeddable Dual Valve Sensor Potted-In Cable 	Ni 4-DS20-2AP6X2	M1650022	Short-Circuit Protection	4	Dual PNP
	Ni 4-DS20-2Y1X2	M1050002	Short-Circuit Protection up to 15 VDC	4	Dual NAMUR

Target Pucks on pages E19-E23.



Most Ni 4-DS20-2Y1X2-... dual valve sensors are FM approved as intrinsically safe for installation in Class I, Division 1 hazardous locations per TURCK control drawing IS-1.000 (www.turck.com/fmcd).

Valve Sensors

Voltage	Switching Freq. (Hz)	Switching Current (mA) VAC/VDC	Operating Temp. (°C)	Protection	Housing	Face	Power LED	Output LED	Mating Cord, Cable Length/ Jacket	Wiring Diagram #	Wiring Diagrams
10-30 VDC	50	200	-25 to +70	IP67	PBT	PBT	No	YE/YE	RK 4.41T-*	1	<p>Diagram 1</p>
5-30 VDC	50	Remote	-25 to +70	IP67	PBT	PBT	No	RD/RD	RK 4.41T-*	2	<p>Diagram 2</p>
10-30 VDC	50	200	-25 to +70	IP67	PBT	PBT	No	YE/YE	2M/PVC	4	<p>Diagram 4</p>
5-30 VDC	50	Remote	-25 to +70	IP67	PBT	PBT	No	RD/RD	2M/PVC	5	<p>Diagram 5</p>

* Length in meters.

TURCK Valve Sensors



Housing Style	Part Number	ID Number	Features	Sensing Range (mm)	Output
16 mm - Embeddable, Vprox 773™, Potted-In Cable 	Bi 2.5-EG16CA-FDZ32X2	T4205100-1	Prog. Outputs Low Temp. -40°C Short-Circuit Protection	2.5	2-Wire AC/DC
16 mm - Embeddable, Vprox 773, minifast® Connector 	Bi 2.5-EG16CA-FDZ32X2-B1151	T4205190	Prog. Outputs Low Temp. -40°C Short-Circuit Protection	2.5	2-Wire AC/DC



TURCK Vprox sensors are FM approved for installation in Class I, Division 2 hazardous locations when installed per TURCK control drawing Ni-1.002 (www.turck.com/fmcd).

Valve Sensors

Voltage	Switching Freq. (Hz)	Switching Current (mA) VAC/VDC	Operating Temp. (°C)	Protection	Housing	Face	Power LED	Output LED	Mating Cord, Cable Length/ Jacket	Wiring Diagram #	Wiring Diagrams
20-250 VAC 10-300 VDC	50	100	-40 to +70	IP67	SS	PA 12	GN	RD	2M/PVC	1	<p>Diagram 1</p> <p>Diagram 2</p>
	50	100	-40 to +70	IP67	SS	PA 12	GN	RD	RKM 50-*M	2	

* Length in meters.

BTS

Valve Sensor Pucks and Accessories

TURCK's valve sensors monitor the position of a valve via rotary actuators. The BTS-DSU35-EBE3, is fully adjustable with interlocking teeth for accurate positioning and feature wide targets for easier adjustments. Along with the puck, TURCK is offering new domes for easy visual indication, and a cover to protect the puck from debris or spills. The domes are available in two colors: red/green and yellow/black. Domes are only compatible with BTS-DSU35-EBE3 pucks and must be ordered separately.



Dome Cover



Puck is not included with Dome. Domes are only compatible with BTS-DSU35-EBE3 pucks.

BTS-DSU35 clip
black (2X)



BTS-DSU35 clip
yellow (2X)

BTS-DSU35-EBE3
Top

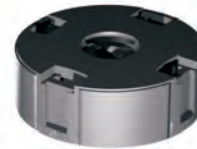

BTS-DSU35-EBE3
Bottom

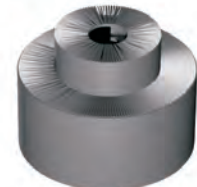

BTS-DSU35-EBE3
Insert



Valve Sensors

Valve Sensor Puck and Dome Cover Drawings

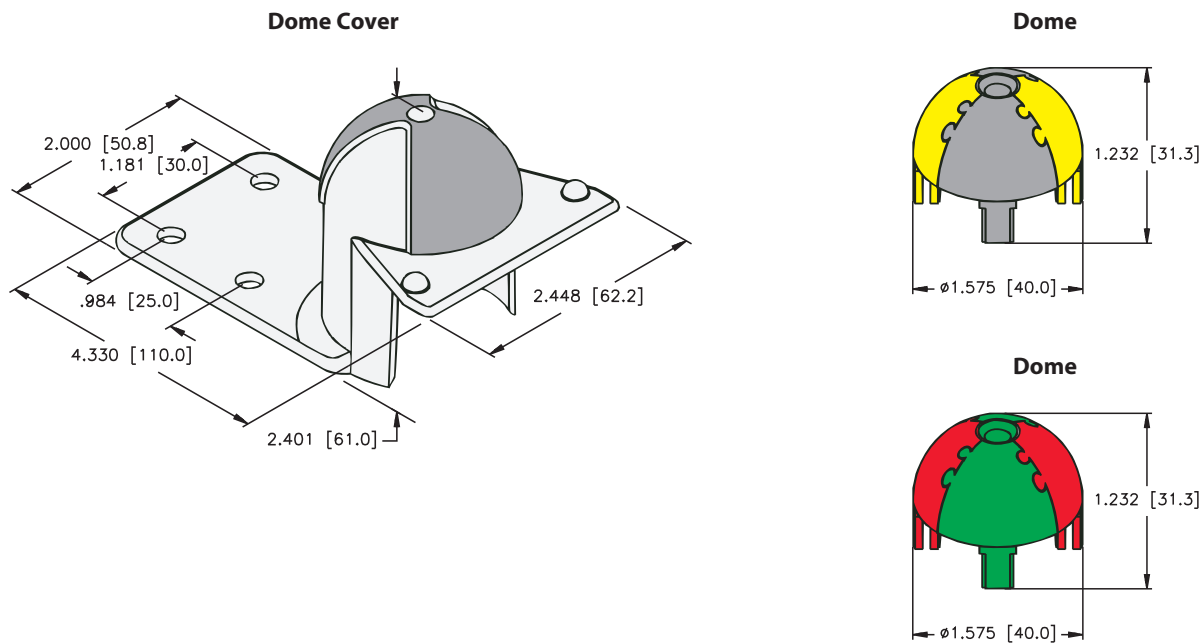

Part Number	ID Number	Description
BTS-DSU35-DOME YE/BK	M6901072	Yellow/Black indicators
BTS-DSU35-DOME RD/GN	M6901073	Red/Green indicators
BTS-DSU35-DOME COVER-US	M6901075	Includes 10-32 screws
BTS-DSU35-DOME COVER	M6901074	Includes M5 screws
BTS-DSU35-EBE3-US	M6901071	Includes 10-32 screws for sensor
BTS-DSU35-EBE3-US2	M6901079	Includes 10-24 screws for sensor
BTS-DSU35-EBE3	M6901070	Includes M5 screws for sensor

Valve Sensor Puck Selection Guide

Stem Height (A)		20 mm		30 mm		50 mm	
Mounting Dimension (B)		80 mm	130 mm	80 mm	130 mm	80 mm	130 mm
Part Number	Output Function						
DS20	End Position Indication- On	BTS-DS20-TP1 (M6900155)	Consult Factory	BTS-DS20-TK1 (M6900156)	BTS-DS20-TP1 (M6900155)	N/A	N/A
	Adjustable/End Position- On	BTS-DS20-KEY (M6900136)	BTS-DS20-KEY (M6900136)	Consult Factory	Consult Factory	N/A	N/A
DSC26	End Position Indication- On	BTS-DSC26-EB1 (M6900222)	Consult Factory	BTS-DSC26-EB2 (M6900223)	BTS-DSC26-EB3 (M6900224)	Consult Factory	Consult Factory
DSU35	End Position Indication- On	BTS-DSU35-EB1 (M6900225)	BTS-DSU35-EB1 (M6900225)	BTS-DSU35-EB1 (M6900225)	BTS-DSU35-EB1 (M6900225)	BTS-DSU35-EB1 (M6900225) and BTS-DSU35-Z07 (M6900403)	BTS-DSU35-EB1 (M6900225) and BTS-DSU35-Z07 (M6900403)
	Adjustable/End Position- On	BTS-DSU35-EBE3 (M6901070)	BTS-DSU35-EBE3 (M6901070)	BTS-DSU35-EBE2 (M6900228)	BTS-DSU35-EBE2 (M6900228)	BTS-DSU35-EBE3 (M6901070) and BTS-DSU35-Z07 (M6900403)	BTS-DSU35-EBE3 (M6901070) and BTS-DSU35-Z07 (M6900403)
	End Position Indication- Off (NAMUR)	BTS-DSU35-EU1 (M6900227)	BTS-DSU35-EU1 (M6900227)	BTS-DSU35-EU1 (M6900227)	BTS-DSU35-EU1 (M6900227)	BTS-DSU35-EU1 (M6900227) and BTS-DSU35-Z07 (M6900403)	BTS-DSU35-EU1 (M6900227) and BTS-DSU35-Z07 (M6900403)

For stems that exceed 40 mm in diameter, consult drawings for appropriate shim package.

Actuator Side View

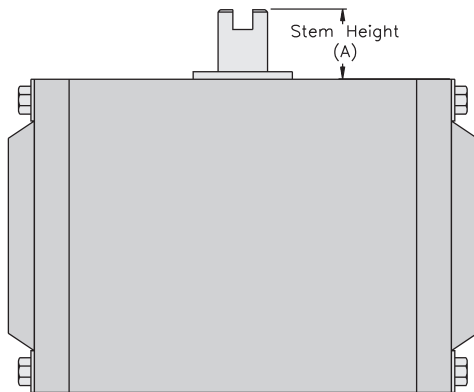

Actuator Top View

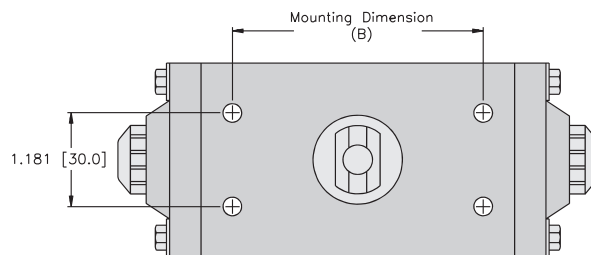

Valve Sensors

DS20 Valve Sensor Kits

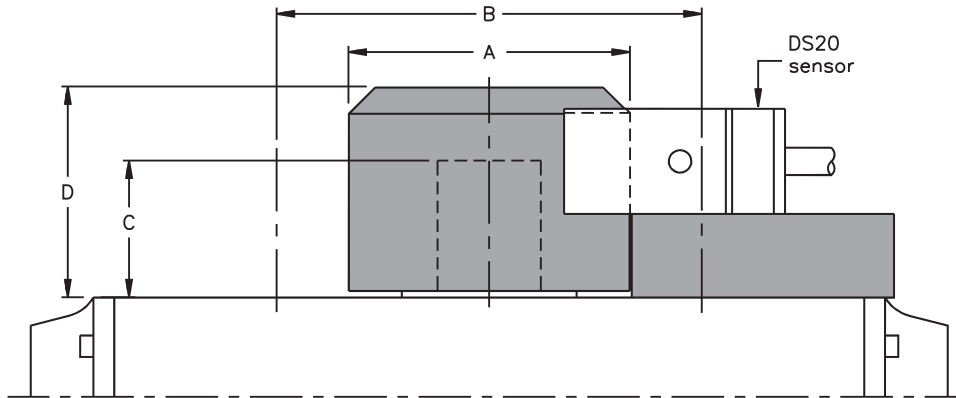

Part Number	Dimensions (mm)				Adjustable	End Position Indication
	A	B	C	D		
BTS-DS20-KEY	40	80x130	20	37	Yes	On

Puck included in package.

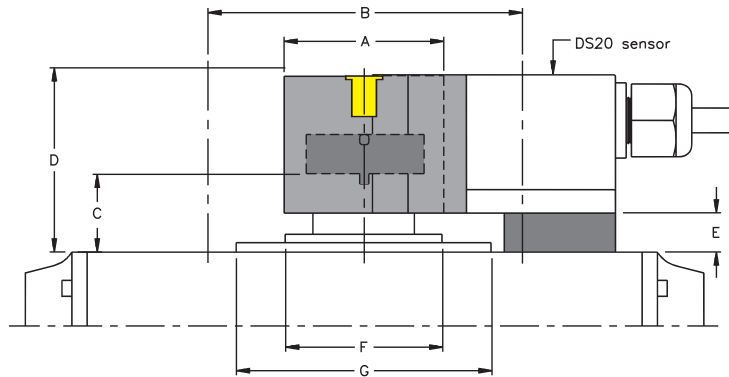

Part Number	Dimensions (mm)						
	A	B	C	D	E	F	G
BTS-DS20-TK1	40	80x130	30	46	10	50	50

Puck included in package.

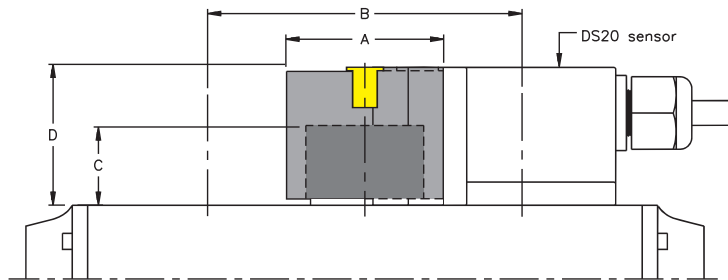

Part Number	Dimensions (mm)				Adjustable	End Position Indication
	A	B	C	D		
BTS-DS20-TP1	40	80	20	36	No	On

Puck included in package.

VALVE

TURCK

Valve Sensors

Valve Sensor Puck Information - DSU35

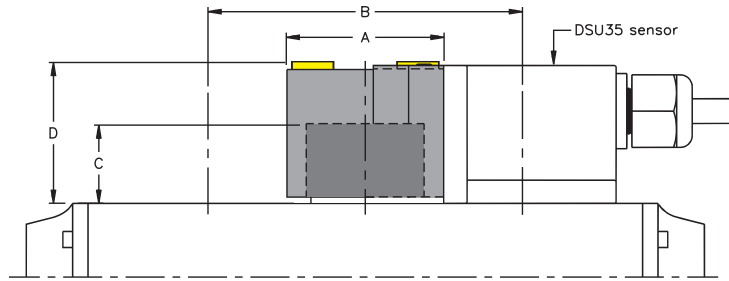

Part Number	Dimensions (mm)				Adjustable	End Position Indication
	A	B	C	D		
BTS-DSU35-EU1	40	80x130	20	36	No	Off

For use with NAMUR Sensors (Y1 output)

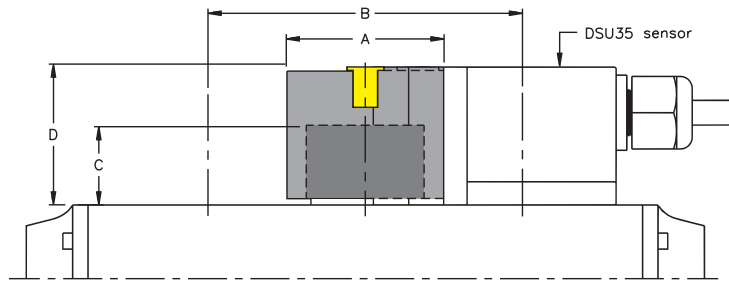

Part Number	Dimensions (mm)				Adjustable	End Position Indication
	A	B	C	D		
BTS-DSU35-EB1	40	80x130	20	36	No	On
BTS-DSU35-EBE1	40	80x130	20	36	Yes	On
BTS-DSU35-EBE2	40	80x130	30	47	Yes	On
BTS-DSU35-EBE3	40	80x130	20	36	Yes	On

Valve Sensor Puck Information - DSU26 or DSC26

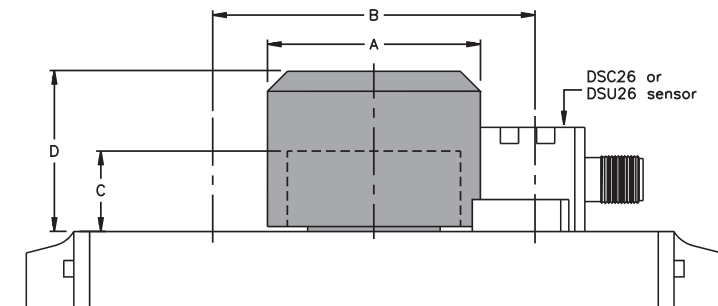

Part Number	Dimensions (mm)			
	A	B	C	D
BTS-DSC26-EB1-2	53	80	20	40
BTS-DSC26-EB2	65	80	30	50
BTS-DSC26-EB3	102	130	30	50

Valve Sensors

DSU35 - Mounting Kits

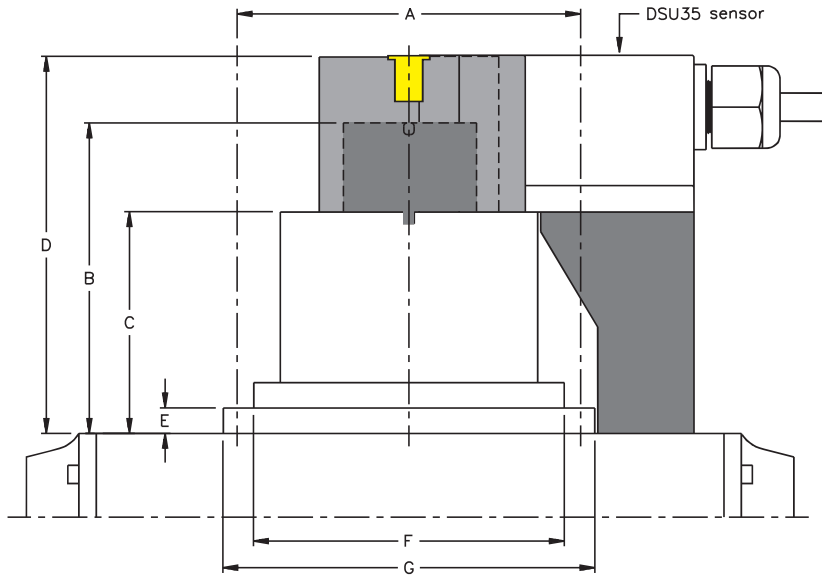

Part Number	Dimensions (mm)						
	A	B	C	D	E	F	G
BTS-DSU35-Z03	130	50	30	65	19 (max)	70	110
BTS-DSU35-Z07	130	70	50	85	19 (max)	10	110

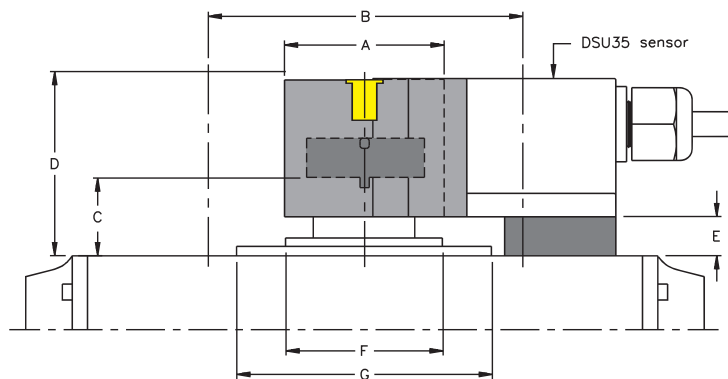

Part Number	Dimensions (mm)						
	A	B	C	D	E	F	G
BTS-DSU35-Z01	40	80x130	20	45	10	40	65
BTS-DSU35-Z02	40	80x130	20	55	20	40	65
BTS-DSU35-Z04	40	80x130	30	45	10	40	65
BTS-DSU35-Z05	40	80x130	30	55	20	30	65
BTS-DSU35-Z06	40	80x130	30	65	30	40	65

"Z" mounting packages include shims to increase height of sensor and do not include pucks. Target pucks must be ordered separately.

VALVE

Valve Sensor Accessories for Class I, Division 2 Applications

GUARD-DSU35-AD
 (A9235)

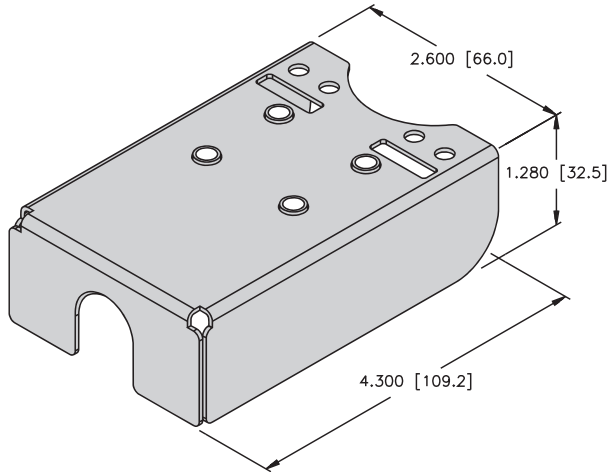

For use with: Ni 4-DSU35-ADZ35X2-B1151

GUARD-DSU35-DC
 (A9234)

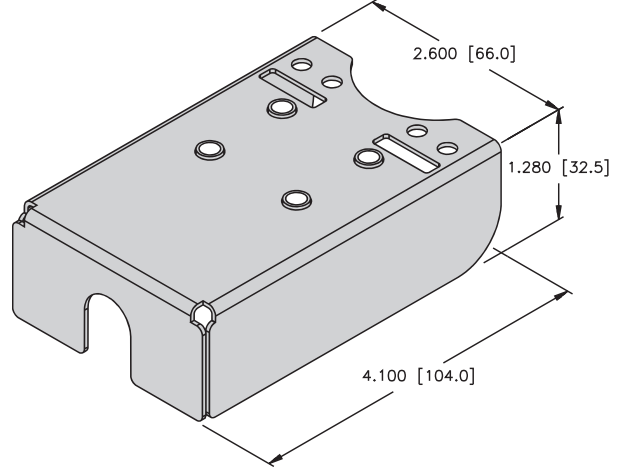

For use with: Ni 4-DSU35-2AP4X2-H1140
 Ni 4-DSU35-2AN4X2
 Ni 4-DSU35-2ADZ35X2

GUARD-DSU35-DCS
 (A9287)

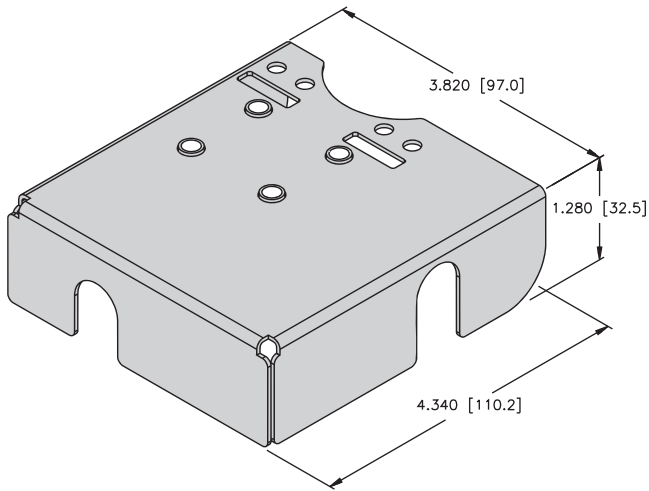

For use with: Ni 4-DSU35-2AP4X2-B1160-FKE4.5

GUARD-DSU35
 (A9150)

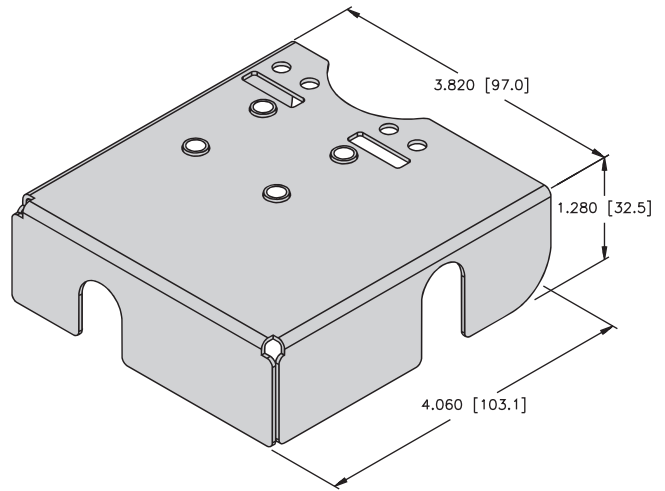

For use with: Ni 4-DSU35-2ASIX4
 Ni 4-DSU35-2DNETX5





Valve Sensors



Notes:

VALVE

INSTRUMENTATION CONNECTIVITY SELECTION GUIDE

Housing	Style	Features	Page
	M12x1 eurofast®	<ul style="list-style-type: none"> ■ 4 to 12 pins ■ Up to 4A and 250V ■ IP68/IP69k ■ Optional LEDs ■ Multiple cable options 	G3
	7/8-16UN minifast®	<ul style="list-style-type: none"> ■ 2 to 12 and 19 pins ■ Up to 10A and 600V ■ IP67/IP68 ■ Multiple cable options 	G5
	1/2-20UNF microfast®	<ul style="list-style-type: none"> ■ 2 to 6 pins ■ Up to 4A and 250V ■ IP67/IP68/IP69k ■ Multiple cable options 	G6
	M8x1 picofast®	<ul style="list-style-type: none"> ■ 3, 4 and 6 pins ■ Up to 4A and 125V ■ IP67 ■ Threaded and snap couplings ■ Multiple cable options 	G7

INSTRUMENTATION CONNECTIVITY PRODUCT OVERVIEW

WHAT CONNECTIVITY PRODUCTS DOES TURCK OFFER FOR USE IN CONJUNCTION WITH ITS INSTRUMENTATION PRODUCTS?

Standard PVC Insulation

TURCK PVC cable has a standard temperature rating of +105°C (+221°F), a high dielectric strength and insulation resistance. It also has an outstanding resistance to ozone, acids, alkalis, alcohols, most solvents, oils, gasoline, greases and waxes. All TURCK PVC is weather and atmosphere rated to UL 62 for ultraviolet radiation resistance. It is inherently tough and flame, abrasion, and moisture resistant. Oil resistant varieties used on TURCK cordsets will not soften or swell in the presence of oil. The plasticizer used in PVC may, however, migrate. Continuous exposure to hot oil and cutting fluids may cause embrittlement and cracking.

Our standard cable construction is PVC insulated inner conductors of high-flex stranding with extruded outer jacket. A separator is utilized to ensure easy machine and hand stripping. Extruded construction is inherently non-wicking because of the absence or minimal use of fillers. Extrusion also minimizes convolutions and provides a near-perfect circular cross section. Standard PVC is used in *euromast*®, *minifast*®,

microfast®, *picofast*®, and *V*fast*®, valve connector cordsets and carries CSA and UL approvals. Some PVC cables also have MSHA approval – consult factory for specifics.

/S90 – Thermoplastic Polyurethane

Our TPU (Thermoplastic Thermoplastic Polyurethane) cable is over-jacketed and bonded to a PVC inner core. The extruded construction is inherently non-wicking. The TPU over-jacket provides superior resistance to oils and lubricants, including cutting oils, transmission fluids (ATF), and gasoline. The abrasion resistance is comparable to Neoprene or other rubber including thermoset rubbers. TURCK “/S90” cable is UL listed and flame resistant to UL 94 VO. TPU is not degraded by exposure to Ozone, making it excellent for outdoor use.

TURCK “/S90” cable carries CSA and UL approvals and is used in *euromast*, *minifast*, *microfast*, *picofast* and *multifast* and valve connector

cordsets. With an “/S90” indicator some TPU cables also have MSHA approval – consult factory for specifics.

/S101 – fl xlife®-20

This is a unique construction of high-flex, low stress cable using custom compounded TPE or TPU extruded jacket with flexible stranded conductors. It is designed for robotic and other continuous motion applications. *flexlife-20* guarantees increased performance to provide 20 million cycles of continuous flexing, bending, and twisting motion found in C-track, robotic and other motion systems.



2, 3, 4 and 5-Wire eurofast® Cordsets, Standard and 6-Wire "C" Style Medium Plug Body

- Straight Female and Male Connectors
- NEMA 1, 3, 4, 6P and IEC IP68 Protection
- 250 VAC/300 VDC, 4 A up to 5-pin
- 60 VAC/75 VDC, 2 A, 6-pin



Housing Style	Part Number	Cable	Features	Pinouts	
<p>RK ..**</p> <p>RKK ..**</p> <p>RKV ..**</p>	RK 4.22T-*	AWM PVC Grey 2x20 AWG 105°C 5.2 mm OD Cable #RF50529-*M	flexlife	1. BN 2. N/C 3. BU 4. N/C	
	RK 4T-*	AWM PVC Grey 3x20 AWG 105°C 5.2 mm OD Cable #RF50528-*M	flexlife	1. BN 2. N/C 3. BU 4. BK	
	RK 4T-*/S618	AWM PVC Grey 3x20 AWG Foil/Drain 105°C 5.7 mm OD Cable #RF50611-*M	RFI/EMI Protection		
	RK 4.41T-*	AWM PVC Namur Blue 4x22 AWG 105°C 5.2 mm OD Cable #RF50598-*M	flexlife	1. BN 2. WH 3. BU 4. BK	
	RK 4.4T-*	AWM PVC Grey 4x22 AWG 105°C 5.2 mm OD Cable #RF50516-*M	flexlife		
	RK 4.4T-*/S90	AWM PUR Grey 4x22 AWG 105°C, 5.2 mm OD Cable #RF50532-*M	Cut/Abrasion Immune		
	RK 4.5T-*	AWM PVC Grey 5x22 AWG 105°C 5.7 mm OD Cable #RF50543-*M	flexlife	1. BN 2. WH 3. BU 4. BK 5. GY	
<p>RS ..</p>	RS 4.4T-*	AWM PVC Grey 4x22 AWG 105°C 5.2 mm OD Cable #RF50516-*M	flexlife	1. BN 2. WH 3. BU 4. BK	
	<p>RKC ..</p>	RKC 6T-*	AWM PVC Grey 6x24 AWG 105°C 5.7 mm OD Cable #RF50608-*M	flexlife	1. BN 2. WH 3. BU 4. BK 5. GY 6. PK

* Length in meters.

Standard cable lengths are 2, 4, 6, 8 and 10 meters. Consult factory for other lengths.

** Standard coupling nut material is nickel plated brass "RK .."; "RKK .." indicates nylon and "RKV .." indicates 316 stainless steel.

Industrial Connectivity Products

2 and 5-Wire eurofast[®] and minifast[®] Network Cordsets

- Straight Female Connectors
- NEMA 1, 3, 4, 6P and IEC IP68 Protection



Housing Style	Part Number	Cable	Features	Pinouts	
<p>RKC ..**</p>	RKC 254-*M	CMG PVC Yellow 2x16 AWG 105°C 250 V, 4 A 7.2 mm OD Cable #RB50852-*M	AS-I Communication	1. BN 2. N/C 3. BU 4. N/C	
<p>RKM ..**</p>	RKM 254-*M	CMG PVC Yellow 2x16 AWG 105°C 300 V, 9 A 7.2 mm OD Cable #RB50852-*M	AS-I Communication	1. BN 2. N/C 3. BU 4. N/C	
<p>RKM ..**</p>	RKM 572-*M	AWM PVC Grey 4x22 AWG, 22 AWG Shield 75°C 300 V, 9 A 7.2 mm OD Cable #RB50603-*M	DeviceNet [®] Communication	1. Shield 2. RD 3. BK 4. WH 5. BU	

* Length in meters.

Standard cable lengths are 2, 4, 6, 8 and 10 meters. Consult factory for other lengths.

** Standard coupling nut material is nickel plated brass "RKC/RKM .."; "RKC/RKV" indicates 316 stainless steel.

4 and 5-Wire *minifast*® Connectors, Standard Plug Body

- Straight Female Connectors
- NEMA 1, 3, 4, 6P and IEC IP67 Protection



Housing Style	Part Number	Cable Specs.	Features	Pinouts
<p>RKM ..**</p>	RKM 46-*M	<p>STOW PVC Yellow 4x16 AWG 105°C 600 V, 9 A 11 mm OD Cable #RF50538-*M</p>	flexlife	<p>1. BK 2. WH 3. RD 4. GN</p>
<p>RKM ..**</p>	RKM 50-*M	<p>AWM PVC Yellow 5x18 AWG 105°C 300 V, 9 A 7.3 mm OD Cable #RF50549-*M</p>	flexlife	<p>1. BK 2. BU 3. GN/YE 4. BN 5. WH</p>

* Length in meters.

Standard cable lengths are 2, 4, 6, 8 and 10 meters. Consult factory for other lengths.

** Standard coupling nut material is nickel plated brass "RKM .."; "RK .." indicates nylon and "RKV .." indicates 316 stainless steel.

3, 4 and 5-Wire *microfast*® Cordsets, Standard Duty

- Straight Female Connectors
- NEMA 1, 3, 4, 6P and IEC IP67 Protection
- 250 V, 4.0 A



Housing Style	Part Number	Cable Specs.	Features	Pinouts
<p>KB ..**</p>	KB 3T-*	AWM PVC Yellow 3x22 AWG 105°C 5.2 mm OD Cable #RF50531-*M	<i>flexlife</i>	1. GN 2. RD/BK 3. RD/WH
<p>KBK ..**</p>	KB 4T-*/S727	AWM PUR Grey 4x22 AWG 105°C 5.2 mm OD Cable #RF50532-*M	Special conductor color code	1. BN 2. BU 3. BK 4. WH
	KB 5T-*	AWM PVC Yellow 5x22 AWG 105°C 5.7 mm OD Cable #RF50556-*M	<i>flexlife</i>	1. RD/WH 2. RD 3. GN 4. RD/YE 5. RD/BK

* Length in meters.

Standard cable lengths are 2, 4, 6, 8 and 10 meters. Consult factory for other lengths.

** Standard coupling nut material is nickel plated brass "KB .."; "KBK .." indicates nylon and "KBV .." indicates 316 stainless steel.

3-Wire *pico fast*® Cordsets, Snap Lock (Locking Sleeve) and Threaded Coupling Nut

- Straight Female Connectors
- NEMA 1, 3, 4, 6P and IEC IP67 Protection
- 125 VAC/VDC, 4 A, for 3-pin
- 125 VAC/VDC 2 A, for 4-pin



Housing Style	Part Number	Cable Specs.	Features	Pinouts
<p>PKG ..Z**</p> <p>LOCKING SLEEVE</p>	PKG 3Z-*	AWM PVC Yellow 3x24 AWG 105°C 4.4 mm OD Cable #RF50642-*M	flexlife	1. BN 2. BU 3. BK
<p>PKG ..M**</p> <p>M8x1</p>	PKG 3M-*	AWM PVC Yellow 3x24 AWG 105°C 4.4 mm OD Cable #RF50642-*M	flexlife	1. BN 2. BU 3. BK
<p>PKG V ..M**</p> <p>M8x1</p>	PKG 4M-*	AWM PVC Yellow 4x26 AWG 105°C 4.4 mm OD Cable #RF50697-*M	flexlife	1. BN 2. WH 3. BU 4. BK

* Length in meters. Standard cable lengths are 2, 4, 6, 8 and 10 meters.

** Standard coupling nut material is POM.. "PKG..Z".

** Standard coupling material is nickel plated brass."PKG..M"; "PKG V..M" indicates 316 stainless steel.

Notes:

Enclosure Ratings

IEC 529

IP40 Protection against solid bodies larger than 1 mm. No protection against liquids.

IP65 Dust tight. Protection against water spray from all directions at 14.2 PSI through a 12.5 mm nozzle.

IP67 Dust tight. Protection against the effects of immersion in water for 30 minutes at 1 meter.

IP68 Dust tight. Protection against the effects of indefinite immersion in water at a pressure specified by the manufacturer. Ex. **TURCK's** IP68 definition is IP67 plus.

- 24 hours at 70°C
- 24 hours at -25°C
- 7 days at 1 meter under water at a constant temperature
- 10 cycles +70°C and -25°C, minimum of 1 hour @ each temperature

IP69K Hot steam jet cleaning per EN 60529 (IP enclosure ratings) and DIN 40050-9

Material Descriptions

Plastics

ABS - Acrylonitrile-Butadiene-Styrene	Impact resistant, rigid. Resistant to aqueous acids, alkalis, salts, alcohols, oils, concentrated hydrochloric acid; disintegrated by concentrated sulfuric or nitric acids, esters, ketones.
CPE, Thermoset (rubber cables)	Excellent resistance to oils, acids, chemicals, ozone, extreme temperatures, cuts, abrasions; flame retardant in welding applications.
PA - Polyamide (nylon)	Good mechanical strength, temperature resistant.
PA, Amorphous (Trogamid T)	Similar properties to nylon, but transparent. Hard, rigid, good chemical resistance.
PA 12-GF30	Nylon 12, 30% glass filled.
PA 66-GF25-V0	Nylon 66, 25% glass filled, self-extinguishing.
PBT - Polybutylene Terephthalate (when glass reinforced, Crastin®)	Good mechanical strength; resistant to abrasion; resistant to alcohols, oils, some acids, trichloroethylene.
PBT-GF30-V0	PBT, 30% glass filled, self-extinguishing.
PEI - Polyetherimide (Ultem®)	Excellent resistance to most commercial automotive fluids, fully hydrogenated hydrocarbons, alcohols, weak aqueous solutions. Withstands higher temperatures.
POM - Polyoxymethylene / Polyacetal (Delrin®)	High impact resistance; good mechanical strength; good resistance to oils, alcohols, alkalis, gasoline, xylene, toluene. Dielectric constant 3.7.
PP - Polypropylene	Excellent resistance against chemicals including acids, solvents and solutions. High temperature resistance and good mechanical strength.
PTFE - Polytetrafluoroethylene	Optimum resistance against high temperature and chemicals; low dielectric constant (2.0).
TPU - Polyurethane	Elastic, resistant to abrasion, impact-resistant, oil- and grease-tolerant.
PVC - Polyvinylchloride	Good mechanical strength, viscosity to impact; resistant to acids, alkalis.
PVC, irradiated	Heat and chemical resistant, withstands short-term temperatures to 482° F.
PVDF - Polyvinylidene fluoride (Kynar®)	Resistant to high and low temperatures, good resistance to chemicals (similar to PTFE), high mechanical strength.
Silicon	For use at high or low ambient temperatures (-50...+180 °C), moderate mechanical strength, average resistance against alkalis, acids, oils, and solvents.
IRPA12 - Irradiated Polyamide (nylon)	Good mechanical strength, temp. resistant.
EPTR - Elastomer, Polymer Thermal Plastic	Good fluid resistance.
TROG - Trogamid T	Hard, rigid, good chemical resistance.

Metals

AG	armorguard ®
SS - 306 Stainless Steel	Excellent atmospheric resistance.
CPB	Chrome Plated Brass
CuZn - Brass	Generally good resistance to industrial atmospheres.
GD - AlSi12 - Aluminum, die-cast	Low specific weight, long-life characteristics.
GD - ZnAl4Cu1 (Z410) - Zinc, die-cast	Long-life characteristics.
TC	PTFE Coated
WG	weldguard ®
AL - Anodized Aluminum	Long-life characteristics
NPB	Nickel Plated Brass
SF - Stoneface®	High abrasion resistance, excellent for MIG welding applications, high heat and weld flow immunity.
TS - Tool Steel	Excellent durability.

Third Party Compliances



CSA - Canadian Standards Association

CSA certifies devices for use in Canadian and American hazardous and non-hazardous locations.



FM - Approvals

FM approves devices for use in explosive hazardous locations in the US. Intrinsically safe (IS) devices are approved for Division 1 areas; nonincendive (NI) devices are approved for Division 2 areas.



UL - Underwriter's Laboratories

UL is a nationally recognized US test laboratory that tests equipment to meet US standards and jurisdictional requirements. UL lists stand-alone devices, such as sensors, and recognizes system components, such as relays.



Note: TURCK products comply with many International standards. Consult factory for more information.

Hazardous Location Approvals

The NAMUR sensors shown in this catalog are Intrinsically Safe per the following:



EUROPE: CENELEC Standards EN 50 014 and EN 50 020; EC Directive 94/9/EC (ATEX)

USA, CANADA: Class I, II, III Division 1 Groups A, B, C, D, E, F, G*

Any FM approved or CSA certified associated apparatus with the following Entity Concept parameters can be used with these sensors:

$$\begin{array}{ll} V_{OC} \text{ or } V_T \leq 15 \text{ V} & C_a \geq C_{\text{cable}} + 220 \text{ nF} \\ I_{SC} \text{ or } I_T \leq 60 \text{ mA} & L_a \geq L_{\text{cable}} + 280 \mu\text{H} \end{array}$$

* Note: CSA does not allow the use of quick disconnects in Groups E and F

Many 3-wire DC sensors are Nonincendive for Class I, Division 2 hazardous areas and Suitable for Class II and Class III, Division 2 hazardous areas. Only those 3-wire sensors identified with the FM logo have this approval.

USA: Class I, II, III Division 2 Groups A, B, C, D, F, G

-AN6X, -AP6X

-RN6X, -RP6X

Factory P/N's ending in /S1751

Integrated cables and cordsets must have ITC-ER Rating.



Nonincendive

More on Hazardous Locations

Standards for Intrinsically Safe systems in hazardous locations are found in the following publications:

- United States: National Electrical Code 1996 (ANSI/NFPA 70) Articles 504 and 505
Factory Mutual Approval Standard Class No. 3610
Underwriters Laboratory Standard UL 913
- Canada: Canadian Electrical Code C22.1-94 Section 18 and Appendix F.
- Europe: CENELEC Standards EN 50 020 and EN 50 014

Hazardous Location Definitions (U.S. and Canada)

- | | |
|------------|---|
| Class I | Locations in which flammable gases or vapors exist or may be present in the air in quantities sufficient to produce explosive or ignitable mixtures. |
| Class II | Locations that are hazardous because of the presence of combustible dust. |
| Class III | Locations that are hazardous because of the presence of easily ignitable fibers or flyings, but in which such fibers or flyings are not likely to be suspended in the air in quantities sufficient to produce ignitable mixtures. |
| Division 1 | Locations in which hazardous concentrations in the air exist continuously, intermittently, or periodically under normal operating conditions. |
| Division 2 | Locations in which hazardous materials are handled, processed or used, but in which they are normally confined within closed containers or closed systems from which they can escape only in case of accidental rupture or breakdown. |
| Group A | Atmospheres containing acetylene. |
| Group B | Atmospheres containing hydrogen, fuel and combustible process gases containing more than 30% hydrogen by volume, or gases or vapors of equivalent hazard such as butadiene, ethylene oxide, propylene oxide and acrolein. |
| Group C | Atmospheres such as ethyl ether, ethylene, acetaldehyde, cyclopropane, or gases or vapors of equivalent hazard. |
| Group D | Atmospheres such as acetone, alcohol, ammonia, benzene, butane, cyclopropane, ethylene dichloride, gasoline, hexane, lacquer solvent vapors, methane, natural gas, naphtha, propane, xylene, or gases or vapors of equivalent hazard. |
| Group E | Atmospheres containing combustible metal dusts, including aluminum, magnesium, and their commercial alloys, and other combustible dusts with similarly hazardous characteristics. |
| Group F | Atmospheres containing combustible carbonaceous dusts, including carbon black, charcoal and coal. |
| Group G | Atmospheres containing other combustible dusts, such as chemical, agricultural or plastic dusts. |

Exerpt from National Electrical Code:

Intrinsically safe apparatus and wiring shall be permitted in any hazardous (classified) location for which it is approved, and the provisions of Articles 501 through 503 and 510 through 516 shall not be considered applicable to such installations except as required by Article 504.

Wiring of intrinsically safe circuits shall be physically separated from wiring of all other circuits that are not intrinsically safe. Means shall be provided to minimize the passage of gases and vapors. Installation of intrinsically safe apparatus and wiring shall be in accordance with the requirements of Article 504.

Index

91-SSP 01 Ft E62	BC10-M30K-AN4X-H1141 E29	BC15-K34-AP4X-H1141 E39
91-SSP 02 Ft E62	BC10-M30K-AP4X-H1141 E29	BC15-K34-AZ3X E39
91-SSP 03 Ft E62	BC10-M30K-AZ3X E31	BC15-K34SR-FZ3X2 E41
91-SSP 04 Ft E62	BC10-M30K-AZ3X-B3131 E29	BC15-K34SR-VN4X2 E41
91-SSP 05 Ft E62	BC10-M30K-RZ3X E31	BC15-K34SR-VP4X2 E41
91-SSP 06 Ft E62	BC10-M30K-RZ3X-B3131 E29	BC15-K34-VN4X E39
91-SSP 07 Ft E62	BC10-M30K-VN4X E31	BC15-K34-VP4X E39
91-SSP 08 Ft E62	BC10-M30K-VN4X-H1141 E29	BC20-CP40-FZ3X2 E19
91-SSP 09 Ft E62	BC10-M30K-VP4X E31	BC20-CP40-VN4X2 E19
91-SSP 10 Ft E62	BC10-M30K-VP4X-H1141 E29	BC20-CP40-VP4X2 E19
BC 3-M12-AN6X E21	BC10-P30SR-FZ3X2-B1131 E37	BC20-K40SR-FZ3X2 E41
BC 3-M12-AN6X-0.2M-RS 4T E21	BC10-P30SR-FZ3X2-B2131 E37	BC20-K40SR-VN4X2 E41
BC 3-M12-AP6X E21	BC10-P30SR-FZ3X2-B3131 E37	BC20-K40SR-VP4X2 E41
BC 3-M12-AP6X-0.2M-RS 4T E21	BC10-P30SR-VN4X2 E35	BC20-K40WDTCC-VP4X2/S930 E41
BC 3-S12-AN6X E21	BC10-P30SR-VN4X2-B2141 E37	BC20-Q20-AN4X2 E15
BC 3-S12-AN6X-0.2M-RS 4T E21	BC10-P30SR-VN4X2-H1141 E37	BC20-Q20-AN4X2/S400 E15
BC 3-S12-AP6X E21	BC10-P30SR-VP4X2 E35	BC20-Q20-AN4X2-H1141 E17
BC 3-S12-AP6X/S100 E21	BC10-P30SR-VP4X2-B1141 E37	BC20-Q20-AP4X2 E15
BC 3-S12-AP6X-0.2M-RS 4T E21	BC10-P30SR-VP4X2-B2141 E37	BC20-Q20-AP4X2/S400 E15
BC 5-M18-AN4X E23	BC10-P30SR-VP4X2-H1141 E37	BC20-Q20-AP4X2-H1141 E17
BC 5-M18-AN4X-0.2M-RS 4T E23	BC10-PT30-VN4X2 E35	BC20-Q20-AP4X2-H1141/S400 E17
BC 5-M18-AP4X E23	BC10-PT30-VP4X2 E35	BC20-Q20-AZ3X2 E15
BC 5-M18-AP4X-0.2M-RS 4T E23	BC10-PT30-YOXX E35	BC20-Q20-AZ3X2/S400 E15
BC 5-M18-AZ3X E23	BC10-Q14-AN4X2 E11	BC20-Q20-VN4X2-H1141 E17
BC 5-M18-AZ3X-0.2M-SB 3T E23	BC10-Q14-AN4X2/S400 E11	BC20-Q20-VN4X2-H1141/S400 E17
BC 5-Q08-AN6X2/S250 E9	BC10-Q14-AN4X2-V1131/S400 E11	BC20-Q20-VP4X2-H1141 E17
BC 5-Q08-AN6X2-V1131/S250 E9	BC10-Q14-AP4X2 E11	BC20-Q20-VP4X2-H1141/S400 E17
BC 5-Q08-AP6X2/S250 E9	BC10-Q14-AP4X2/S400 E11	BCC10-S30-AP4X-H1141 E33
BC 5-Q08-AP6X2-V1131/S250 E9	BC10-Q14-AP4X2-V1131 E11	BCC10-S30-RP4X-H1143 E33
BC 5-QF5.5-AN6X2/S250 E9	BC10-Q14-AP4X2-V1131/S400 E11	BCC10-S30-VP4X-H1141 E33
BC 5-QF5.5-AP6X2/S250 E9	BC10-Q14-VN4X2 E11	BCF 5-S18-AN4X E27
BC 5-QF5.5-RP6X2/S250 E9	BC10-Q14-VP4X2 E11	BCF 5-S18-AN4X-0.2M-RS 4T E25
BC 5-QF5.5-YOXX/S250 E9	BC10-QF5.5-AN6X2 E9	BCF 5-S18-AP4X E27
BC 5-QF5.5-Y1X/S250 E9	BC10-QF5.5-AN6X2/S250 E9	BCF 5-S18-AP4X/S90 E27
BC 5-S185-AN4X E27	BC10-QF5.5-AN6X2/S932 E9	BCF 5-S18-AP4X-0.2M-RS 4T E25
BC 5-S185-AN4X/S100 E27	BC10-QF5.5-AP6X2 E9	BCF10-Q20L60-AP4X E13
BC 5-S185-AN4X-0.3M-RS 4T E25	BC10-QF5.5-AP6X2/S250 E9	BCF10-S30-AZ3X E35
BC 5-S185-AP4X E27	BC10-QF5.5-AP6X2/S932 E9	BCF10-S30-AZ3X-B3131 E33
BC 5-S185-AP4X/S100 E27	BC10-QF5.5-RN6X2 E9	BCF10-S30-RZ3X-B3131 E33
BC 5-S185-AP4X-0.2M-RS 4T E25	BC10-QF5.5-RN6X2/S932 E9	BCF10-S30-VN4X E35
BC 5-S18-AN4X E27	BC10-QF5.5-RP6X2 E9	BCF10-S30-VN4X-H1141 E33
BC 5-S18-AN4X-0.2M-RS 4T E25	BC10-QF5.5-RP6X2/S250 E9	BCF10-S30-VP4X E35
BC 5-S18-AN4X-H1141/S250 E25	BC10-QF5.5-RP6X2/S932 E9	BCF10-S30-VP4X-H1141 E33
BC 5-S18-AP4X E27	BC10-S30-AZ3X E35	BCF15-K34-AZ3X E39
BC 5-S18-AP4X-0.2M-RS 4T E25	BC10-S30-AZ3X-B3131 E33	Bi 2.5-EG16CA-FDZ32X2 F17
BC 5-S18-AZ3X E27	BC10-S30-RZ3X-B3131 E33	Bi 2.5-EG16CA-FDZ32X2-B1151 F17
BC 5-S18-AZ3X-0.2M-SB 3T E25	BC10-S30-VN4X E35	BTS-DS20-KEY F22
BC 5-S18-YOXX E27	BC10-S30-VN4X-H1141 E33	BTS-DS20-TK1 F22
BC 8-Q10-AN6X2/S250 E11	BC10-S30-VP4X E35	BTS-DS20-TP1 F22
BC 8-Q10-AP6X2/S250 E11	BC10-S30-VP4X-H1141 E33	BTS-DSC26-EB1 F23
BC 8-Q10-AP6X2-V1131/S250 E11	BC10-S30-YOXX E35	BTS-DSC26-EB1-2 F23
	BC15-K34-AN4X-H1141 E39	BTS-DSC26-EB2 F23

Instrumentation Products - Index

Index

BTS-DSC26-EB3	F23	FCI-N3/4D20A4P-AP8X-H1141 . . .	C15	FCS-N1/2A4P-AP8X-H1141/L060 . .	C25
BTS-DSU35-DOME COVER	F20	FCI-N3/4D20A4P-ARX-H1140	C15	FCS-N1/2A4P-AP8X-H1141/L100 . . .	C25
BTS-DSU35-DOME COVER-US	F20	FCI-N3/4D20A4P-LIX-H1141	C15	FCS-N1/2A4P-AP8X-H1141/L120 . . .	C25
BTS-DSU35-DOME RD/GN	F20	FCI-TCD04A4P-AP8X-H1141	C13	FCS-N1/2A4P-ARX-B1151 115VAC . .	C25
BTS-DSU35-DOME YE/BK	F20	FCI-TCD04A4P-ARX-H1140	C13	FCS-N1/2A4P-ARX-B1151 230VAC . .	C25
BTS-DSU35-EB1	F23	FCI-TCD04A4P-LIX-H1141	C13	FCS-N1/2A4P-ARX-B1151/L060/115VAC	C25
BTS-DSU35-EBE1	F23	FCMI-3/4D12DYA4P-LI-UP8X-H1141 . .	C5	FCS-N1/2A4P-ARX-B1151/L080/115VAC	C25
BTS-DSU35-EBE2	F23	FCMI-3/8D08DYA4P-LI-UP8X-H1141 . .	C5	FCS-N1/2A4P-ARX-B1151/L100/115VAC	C25
BTS-DSU35-EBE3	F20	FCS-50A4-AP8X-H1141/D014	C31	FCS-N1/2A4P-ARX-B1151/L120 115VAC	C25
BTS-DSU35-EBE3-US	F20	FCS-64A4-AP8X-H1141/D014	C31	FCS-N1/2A4P-ARX-B1151/L160/115VAC	C25
BTS-DSU35-EBE3-US2	F20	FCS-G1/2A4-AP8X-H1141	C29	FCS-N1/2A4P-ARX-B3141 115VAC . .	C25
BTS-DSU35-EU1	F23	FCS-G1/2A4-AP8X-H1141/L080	C29	FCS-N1/2A4P-ARX-B3141/L060 115VAC	C25
BTS-DSU35-Z01	F24	FCS-G1/2A4-NA/D100	C35	FCS-N1/2A4P-ARX-B3151 115VAC . .	C25
BTS-DSU35-Z02	F24	FCS-G1/2A4-NA-H1141	C35	FCS-N1/2A4P-LIX-H1141	C25
BTS-DSU35-Z03	F24	FCS-G1/2A4P-AP8X-H1141	C25	FCS-N1/2A4P-LIX-H1141/D037	C25
BTS-DSU35-Z04	F24	FCS-G1/2DY-AP8X	C33	FCS-N1/2A4P-RRX-B1151 115VAC . .	C25
BTS-DSU35-Z05	F24	FCS-G1/2DY-AP8X-H1141	C33	FCS-N1/2T-NA	C33
BTS-DSU35-Z06	F24	FCS-G1/2TN-NA-H1141	C37	FCS-N3/4A4-NA-H1141	C35
BTS-DSU35-Z07	F24	FCS-G1/4A4-AP8X-H1141	C29	FD-G1/2AFM30/34	C26
BU-R16-2x3/4 NPT-SS	E54	FCS-G1/4A4-ARX-H1140	C29	FD-G1/4AFM30/34	C30
CF-M-3-N1/4-A4	D20	FCS-G1/4A4-NA-H1141	C35	FK-R16-183-SSES	E54
CF-M-3-N1/8-A4	D20	FCS-G1/4T-NA	C33	FK-R16-183-SSFE	E54
CF-M-6-N1/2-A4	D20	FCS-GL1/2A2P-AP8X-H1141/A	C45	FK-R16-205-SSES	E54
CF-M-6-N1/4-A4	D20	FCS-GL1/2A2P-LIX-H1141/A	C45	Flange, 2 inch Tri-clamp	E53
CF-P-3-N1/4-A4	D20	FCS-GL1/2A4-AP8X-H1141	C29	Flange, 2.5 inch Tri-clamp	E53
CF-P-3-N1/8-A4	D20	FCS-GL1/2A4-NAEX0/A	C47	Flange, 3 inch Tri-clamp	E53
CF-P-6-N1/4-A4	D20	FCS-GL1/2A4-NA-H1141/D500	C35	Flange, 4 inch Tri-clamp	E53
FCI-1/4TCD04A4P-AP8X-H1141	C13	FCS-K20-AP8X	C43	FSV-SS 1/2 KIT	C10
FCI-1/4TCD04A4P-LIX-H1141	C13	FCS-K20-LIX	C43	FSV-SS 1/2 TS-NPT	C10
FCI-D03A4-NA-H1141/M12	C19	FCS-M18-AN8X	C43	FSV-SS 3/4 KIT	C6
FCI-D03A4-NA-H1141/M16	C19	FCS-M18-AP8X	C43	FSV-SS 3/4 TS-NPT	C6
FCI-D04A4P-AP8X-H1141	C15	FCS-M18-AP8X/D041	C43	FSV-SS 3/8 KIT	C6
FCI-D04A4P-LIX-H1141	C15	FCS-M18-AP8X/D087	C43	FSV-SS 3/8 TS-NPT	C6
FCI-D04A4P-NA-H1141	C19	FCS-M18-LIX	C43	FSV-SS-1/2X1/4	C20
FCI-D08A4P-ARX-H1140/D038	C15	FCS-M18-LIX/D041	C43	FSV-SS-1/4X1/4	C20
FCI-D08A4P-NA-H1141/D038	C19	FCS-M18-LIX/D067	C43	FSV-SS-1/8X1/4	C20
FCI-D09A4-NAEX-H1141/M16	C19	FCS-M18-LIX/D087	C43	FSV-SS-3/8X1/4	C20
FCI-D09A4-NA-H1141/M16	C19	FCS-N1/2A4-AN8X-H1141	C29	FTCI-1/2D10A4P-2UP8X-H1141	C9
FCI-D10A4P-2ARX-H1160/D201	C9	FCS-N1/2A4-AP8X-H1141	C29	FTCI-1/2D10A4P-4UP8X-H1160	C9
FCI-D10A4P-2ARX-H1160/D203	C9	FCS-N1/2A4-AP8X-H1141/L060	C29	FTCI-1/2D10A4P-LI-UP8X-H1141	C9
FCI-D10A4P-2ARX-H1160/D205	C9	FCS-N1/2A4-AP8X-H1141/L100	C29	FTCI-3/4D15A4P-2LIX-H1141	C9
FCI-D10A4P-AP8X-H1141	C15	FCS-N1/2A4-ARX-H1140	C29	FTCI-3/4D15A4P-2UP8X-H1141	C9
FCI-D10A4P-ARX-H1140	C15	FCS-N1/2A4-NA	C35	FTCI-3/4D15A4P-4UP8X-H1160	C9
FCI-D10A4P-LIX-H1141	C15	FCS-N1/2A4-NA/D100	C35	FTCI-3/4D15A4P-LI-UP8X-H1141	C9
FCI-D10A4P-NA-H1141	C19	FCS-N1/2A4-NAEX	C39	FTCI-3/8D10A4P-2UP8X-H1141	C9
FCI-D15A4P-2ARX-H1160/D209	C9	FCS-N1/2A4-NAEX/D100	C39	FTCI-3/8D10A4P-4UP8X-H1160	C9
FCI-D15A4P-ARX-H1140	C15	FCS-N1/2A4-NAEX-H1141	C39	FTCI-3/8D10A4P-LI-UP8X-H1141	C9
FCI-D15A4P-LIX-H1141	C15	FCS-N1/2A4-NA-H1141	C35	FTCS-N1/2A4P-2AP8X-H1140	C27
FCI-N1/4D04HC22P-AP8X-H1141	C17	FCS-N1/2A4-NA-H1141/L060	C35	GUARD-DSU35	F25
FCI-N1/4D10HC22P-AP8X-H1141	C17	FCS-N1/2A4-NA-H1141/L100	C35	GUARD-DSU35-AD	F25
FCI-N1/8D06CTP-AP8X-H1141	C17	FCS-N1/2A4P-2AP8X-H1140	C27	GUARD-DSU35-DC	F25
FCI-N1/8D06CTP-ARX-H1140	C17	FCS-N1/2A4P-AP8X-H1141	C25	GUARD-DSU35-DCS	F25

Index

KB 3T-* G6	Ni 4-DSU35-2ADZ35X2-B1151 . . . F9	PS001V-505-LUUPN8X-H1141 . . . B7
KB 4T-*/S727 G6	Ni 4-DSU35-2AN4X2-H1141 F7	PS003V-301-2UPN8X-H1141 B15
KB 5T-* G6	Ni 4-DSU35-2AP4X2-B1160-FKE4.5 . . F9	PS003V-301-LI2UPN8X-H1141 B11
LT*E-R16-3*LI0-EX-B1140 E49	Ni 4-DSU35-2AP4X2-B1160-FKE45 . . F9	PS003V-301-LUUPN8X-H1141 B13
LT*E-R16-3*LI0-EX-S E49	Ni 4-DSU35-2AP4X2-H1141 F7	PS003V-303-2UPN8X-H1141 B15
LT*E-R16-3*LI1-EX-B1140 E49	Ni 4-DSU35-2ASIX4-B1140-FKE4.3 . . F9	PS003V-303-LI2UPN8X-H1141 B11
LT*E-R16-3*LI1-EX-S E49	Ni 4-DSU35-2ASIX4-H1140 F9	PS003V-303-LUUPN8X-H1141 B13
LT*E-R16-3LI0-EX-B1140 E49	NI 4-DSU35-2ASIX4-H1140 F7	PS003V-503-2UPN8X-H1141 B9
LT*E-R16-3LI0-EX-D E49	Ni 4-DSU35-2DNETX5-B1150-FKE4.3F9	PS003V-503-LI2UPN8X-H1141 . . . B5
LT*E-R16-3LI0-EX-S E49	Ni 4-DSU35-2DNETX5-H1150 F9	PS003V-503-LUUPN8X-H1141 B7
LT*E-R16-3LI1-EX-B1140 E49	Ni 4-DSU35-2Y0X2-H1140 F7	PS003V-505-2UPN8X-H1141 B9
LT*E-R16-3LI1-EX-D E49	Ni 4-DSU35-2Y1X2-H1140 F7	PS003V-505-LI2UPN8X-H1141 B5
LT*E-R16-3LI1-EX-S E49	Ni 4-DSU35TC-2ADZ30X2 F11	PS003V-505-LUUPN8X-H1141 B7
LT*E-R16-F*LI0-EX-B1140 E49	Ni 4-DSU35TC-2AP4X2 F11	PS010V-301-2UPN8X-H1141 B15
LT*E-R16-F*LI1-EX-B1140 E49	Ni 4-DSU35TC-2ASIX4 F11	PS010V-301-LI2UPN8X-H1141 B11
LT*E-R16-PCLIO-EX-S E51	Ni 4-DSU35TC-2Y1X2 F11	PS010V-301-LUUPN8X-H1141 B13
LT*E-R16-PCLII1-EX-S E51	PCV-G1/4A4 B35	PS010V-303-2UPN8X-H1141 B15
LT*E-R16-PLIO-EX-D E51	PCV-N1/2A4 B35	PS010V-303-LI2UPN8X-H1141 B11
LT*E-R16-PLII1-EX-D E51	PCV-N1/4A4 B35	PS010V-303-LUUPN8X-H1141 B13
LT*E-R16-S*LI0-EX-B1140 E49	PCV-N1/8A4 B35	PS010V-503-2UPN8X-H1141 B9
LT*E-R16-S*LI1-EX-S E49	PCV-S7/16A4 B35	PS010V-503-LI2UPN8X-H1141 . . . B5
LT*E-R16-S*LI1-EX-B1140 E49	PF-R16 E54	PS010V-503-LUUPN8X-H1141 B7
LT*E-R16-S*LI1-EX-B1140/3A E51	PK010R-N14AL-2UP8X-V1141 B17	PS010V-505-2UPN8X-H1141 B9
MK 91-121-R/24VDC E63	PK010R-P14-2UP8X-V1141 B17	PS010V-505-LI2UPN8X-H1141 B5
MK 91-12-R/024VDC E65	PK010VR-N14AL-2UP8X-V1141 . . . B17	PS016V-301-2UPN8X-H1141 B15
MK 91-12-R/115VAC E65	PK01VR-P14-2UP8X-V1141 B17	PS016V-301-LI2UPN8X-H1141 B11
MK 91-12-R/230VAC E65	PKG 3M-* G7	PS016V-301-LUUPN8X-H1141 B13
MK 91-R11/24VDC E63	PKG 3Z-* G7	PS016V-303-2UPN8X-H1141 B15
MK 96-11-R/024VDC C49	PKG 4M-* G7	PS016V-303-LI2UPN8X-H1141 B11
MK 96-LI01 C49	PS001R-301-2UPN8X-H1141 B15	PS016V-303-LUUPN8X-H1141 B13
MK 96-VP01 C49	PS001R-301-LI2UPN8X-H1141 B11	PS016V-503-2UPN8X-H1141 B9
MS91-12-R E65	PS001R-301-LUUPN8X-H1141 B13	PS016V-503-LI2UPN8X-H1141 . . . B5
MS96-11EX0-R/115VAC C49	PS001R-303-2UPN8X-H1141 B15	PS016V-503-LUUPN8X-H1141 B7
MS96-11EX0-R/24VDC C49	PS001R-303-LI2UPN8X-H1141 B11	PS016V-503-LUUPN8X-H1141 B7
MS96-12R/024VDC C49	PS001R-303-LUUPN8X-H1141 B13	PS016V-505-2UPN8X-H1141 B9
MS96-12R/115VAC C49	PS001R-503-2UPN8X-H1141 B9	PS016V-505-LI2UPN8X-H1141 B5
MS96-12R/230VAC C49	PS001R-503-LI2UPN8X-H1141 . . . B5	PS016V-505-LUUPN8X-H1141 B7
N1/2-G1/2-SST C26	PS001R-503-LUUPN8X-H1141 B7	PS01VR-301-2UPN8X-H1141 B15
NC20-KT34-VP4X2 E39	PS001R-505-2UPN8X-H1141 B9	PS01VR-301-LI2UPN8X-H1141 B11
NC50-CP80-FZ3X2 E19	PS001R-505-LI2UPN8X-H1141 B5	PS01VR-301-LUUPN8X-H1141 B13
NC50-CP80-VN4X2 E19	PS001R-505-LUUPN8X-H1141 . . . B7	PS01VR-303-2UPN8X-H1141 B15
NC50-CP80-VP4X2 E19	PS001V-301-2UPN8X-H1141 B15	PS01VR-303-LI2UPN8X-H1141 B11
Ni 4-DS20-2AP6X2 F15	PS001V-301-LI2UPN8X-H1141 B11	PS01VR-303-LUUPN8X-H1141 B13
Ni 4-DS20-2AP6X2-H1141 F15	PS001V-301-LUUPN8X-H1141 B13	PS01VR-503-2UPN8X-H1141 B9
Ni 4-DS20-2Y1X2 F15	PS001V-303-2UPN8X-H1141 B15	PS01VR-503-LI2UPN8X-H1141 . . . B5
Ni 4-DS20-2Y1X2-H1140 F15	PS001V-303-LI2UPN8X-H1141 B11	PS01VR-503-LUUPN8X-H1141 B7
Ni 4-DSC26-2AP6X2-H1141 F13	PS001V-303-LUUPN8X-H1141 B13	PS01VR-505-2UPN8X-H1141 B9
Ni 4-DSU26-2AP4X2-H1141 F13	PS001V-503-2UPN8X-H1141 B9	PS01VR-505-LI2UPN8X-H1141 B5
Ni 4-DSU26-2ASIX4-H1140 F13	PS001V-503-LI2UPN8X-H1141 . . . B5	PS01VR-505-LUUPN8X-H1141 B7
Ni 4-DSU26-2Y1X2-H1140 F13	PS001V-503-LUUPN8X-H1141 B7	PS025V-301-2UPN8X-H1141 B15
Ni 4-DSU35-2ADZ30X2-B1151 F9	PS001V-505-2UPN8X-H1141 B9	PS025V-301-LI2UPN8X-H1141 B11
NI 4-DSU35-2ADZ30X2-B1160-FKE4.5 . F9	PS001V-505-LI2UPN8X-H1141 B5	PS025V-301-LUUPN8X-H1141 B13

Instrumentation Products - Index

Index

PS025V-303-2UPN8X-H1141	B15	PS250R-505-LUUPN8X-H1141	B7	RKM 254-*M	G4
PS025V-303-LI2UPN8X-H1141	B11	PS400R-301-2UPN8X-H1141	B15	RKM 46-*M	G5
PS025V-303-LUUPN8X-H1141	B13	PS400R-301-LI2UPN8X-H1141	B11	RKM 50-*M	G5
PS025V-503-2UPN8X-H1141	B9	PS400R-301-LUUPN8X-H1141	B13	RKM 572-*M	G4
PS025V-503-LI2UPN8X-H1141	B5	PS400R-303-2UPN8X-H1141	B15	RS 4.4T-*	G3
PS025V-503-LUUPN8X-H1141	B7	PS400R-303-LI2UPN8X-H1141	B11	TB-R16S	E53
PS025V-505-2UPN8X-H1141	B9	PS400R-303-LUUPN8X-H1141	B13	TC-R16-SS	E53
PS025V-505-LI2UPN8X-H1141	B5	PS400R-503-2UPN8X-H1141	B9	THW-3-N1/2-A4-L050	D18
PS025V-505-LUUPN8X-H1141	B7	PS400R-503-LI2UPN8X-H1141	B5	THW-3-N1/2-A4-L100	D18
PS040V-301-2UPN8X-H1141	B15	PS400R-503-LUUPN8X-H1141	B7	THW-3-N1/2-A4-L150	D18
PS040V-301-LI2UPN8X-H1141	B11	PS400R-505-2UPN8X-H1141	B9	THW-3-N1/2-A4-L250	D18
PS040V-301-LUUPN8X-H1141	B13	PS400R-505-LI2UPN8X-H1141	B5	THW-3-N1/4-A4-L050	D18
PS040V-303-2UPN8X-H1141	B15	PS600R-301-2UPN8X-H1141	B15	THW-3-N1/4-A4-L100	D18
PS040V-303-LI2UPN8X-H1141	B11	PS600R-301-LI2UPN8X-H1141	B11	THW-3-N1/4-A4-L150	D18
PS040V-303-LUUPN8X-H1141	B13	PS600R-301-LUUPN8X-H1141	B13	THW-3-N1/4-A4-L200	D18
PS040V-503-2UPN8X-H1141	B9	PS600R-303-2UPN8X-H1141	B15	THW-3-N1/8-A4-L050	D18
PS040V-503-LI2UPN8X-H1141	B5	PS600R-303-LI2UPN8X-H1141	B11	THW-3-N1/8-A4-L100	D18
PS040V-503-LUUPN8X-H1141	B7	PS600R-303-LUUPN8X-H1141	B13	THW-3-N1/8-A4-L150	D18
PS040V-505-2UPN8X-H1141	B9	PS600R-503-2UPN8X-H1141	B9	THW-3-TRI3/4-A4-L035	D18
PS040V-505-LI2UPN8X-H1141	B5	PS600R-503-LI2UPN8X-H1141	B5	THW-3-TRI3/4-A4-L050	D18
PS040V-505-LUUPN8X-H1141	B7	PS600R-503-LUUPN8X-H1141	B7	THW-3-UNI25-A4-L035	D18
PS100R-301-2UPN8X-H1141	B15	PS600R-505-2UPN8X-H1141	B9	THW-6-N1/2-A4-L050	D19
PS100R-301-LI2UPN8X-H1141	B11	PS600R-505-LI2UPN8X-H1141	B5	THW-6-N1/2-A4-L100	D19
PS100R-301-LUUPN8X-H1141	B13	PS-COVER	D19	THW-6-N1/2-A4-L150	D19
PS100R-503-2UPN8X-H1141	B9	PT.../S1049	B32	THW-6-TRI3/4-A4-L050	D19
PS100R-503-LI2UPN8X-H1141	B5	PT.../S1593	B32	TP-103A-G1/8-H1141-L013	D16
PS100R-503-LUUPN8X-H1141	B7	PT.../S1604	B31	TP-103A-G1/8-H1141-L024	D16
PS100R-505-2UPN8X-H1141	B9	PT.../S1605	B31	TP-104A-N1/4-H1141-L005	D16
PS100R-505-LI2UPN8X-H1141	B5	PT.../S1685	B32	TP-104A-N1/4-H1141-L035	D16
PS100R-505-LUUPN8X-H1141	B7	PT.../S1704	B34	TP-104A-TRI3/4-H1141-L100	D15
PS250R-301-2UPN8X-H1141	B15	PT.../S1705	B34	TP-104A-TRI3/4-H1141-L035	D15
PS250R-301-LI2UPN8X-H1141	B11	PT.../S1731	B33	TP-203A-CF-H1141-L050	D15
PS250R-301-LUUPN8X-H1141	B13	PTS Cover	B35	TP-203A-CF-H1141-L100	D15
PS250R-503-2UPN8X-H1141	B9	PTS-MB	D19	TP-203A-CF-H1141-L150	D15
PS250R-503-LI2UPN8X-H1141	B15	RK 4.22T-*	G3	TP-203A-CF-H1141-L200	D15
PS250R-503-LUUPN8X-H1141	B11	RK 4.41T-*	G3	TP-203A-CF-H1141-L250	D15
PS250R-303-LUUPN8X-H1141	B13	RK 4.4T-*	G3	TP-203A-CF-H1141-L300	D15
PS250R-503-2UPN8X-H1141	B9	RK 4.4T-* /S90	G3	TP-206A-CF-H1141-L050	D15
PS250R-503-LI2UPN8X-H1141	B5	RK 4.5T-*	G3	TP-206A-CF-H1141-L100	D15
PS250R-503-LUUPN8X-H1141	B7	RK 4T-*	G3	TP-206A-CF-H1141-L150	D15
PS250R-505-2UPN8X-H1141	B9	RK 4T-* /S618	G3	TP-206A-CF-H1141-L200	D15
PS250R-505-LI2UPN8X-H1141	B5	RKC 6T-*	G3	TP-206A-CF-H1141-L300	D15

Index

TP-206A-CF-H1141-L500	D15
TP-306A-CF-H1141-L1000	D16
TP-306A-CF-H1141-L2000	D16
TP-306A-CF-H1141-L5000	D16
TS-400-2UPN8X-H1141	D5
TS-400-LI2UPN8X-H1141	D5
TS-400-LUUPN8X-H1141	D5
TS-500-2UPN8X-H1141	D5
TS-500-LI2UPN8X-H1141	D5
TS-500-LUUPN8X-H1141	D5
TSG-12	E44
TSG-18	E44
TSG-30	E44
TT-100-LI6-H1140	D9
TT-206A-CF-LI6-H1140-L0100	D9
TT-206A-CF-LI6-H1140-L0150	D9
TTM050C-103A-G1/8-LI6-H1140-L013-50...50°C	D11
TTM050C-103A-G1/8-LI6-H1140-L024-50...50°C	D11
TTM050C-203A-CF-LI6-H1140-L100-50...50°C	D11
TTM050C-203A-CF-LI6-H1140-L150-50...50°C	D11
TTM050C-206A-CF-LI6-H1140-L100-50...50°C	D11
TTM050C-206A-CF-LI6-H1140-L150-50...50°C	D11
TTM100C-103A-G1/8-LI6-H1140-L013	D11
TTM100C-103A-G1/8-LI6-H1140-L024	D11
TTM100C-103A-N1/4-LI6-H1140-L013D11	
TTM100C-103A-N1/4-LI6-H1140-L024	D11
TTM100C-203A-CF-LI6-H1140-L100	D11
TTM100C-203A-CF-LI6-H1140-L150	D11
TTM100C-206A-CF-LI6-H1140-L100D11	
TTM100C-206A-CF-LI6-H1140-L150	D11
TTM150C-203A-CF-LI6-H1140-L100	D11
TTM150C-203A-CF-LI6-H1140-L100-50...150°C	D11
TTM150C-203A-CF-LI6-H1140-L150D11	
TTM150C-203A-CF-LI6-H1140-L150-50...150°C	D11
TTM150C-206A-CF-LI6-H1140-L100	D11
TTM150C-206A-CF-LI6-H1140-L100-50...150°C	D11
TWD-18S	E43
TWD-18S-1	E43
TWD-18S-1NPT	E43
TWD-30S-SHORT	E43
TWT-18S	E43
TWT-18S-1NPT	E43
TWT-30S-SHORT	E43
TWTS-1.5-30	E44
TWTS-2-30	E44
WCC-1138	E61
WCT-2	E61
WK-R16 Weight Kit	E54

Notes:

TURCK

Instrumentation Warranty

Warranty Terms and Conditions

RISK OF LOSS

Delivery of the equipment to a common carrier shall constitute delivery to the Purchaser and the risk of loss shall transfer at that time to Purchaser. Should delivery be delayed due to an act or omission on the part of the Purchaser, risk of loss shall transfer to the Purchaser upon notification by **TURCK Inc.** that the order is complete and ready for shipment.

WARRANTIES

TURCK INC. (hereinafter "**TURCK**") offers five (5) **WARRANTIES** to cover all products sold. They are as follows:

- 1) The **12-MONTH WARRANTY** is available for the products listed - generally those not covered by **LIFETIME, 5-YEAR, 24-MONTH** or **18-MONTH** warranty. No registration required.
- 2) The **18-MONTH WARRANTY** is available for the products listed - generally those not covered by **LIFETIME** or **5-YEAR WARRANTY**. No registration is required.
- 3) The **24-MONTH WARRANTY** is available for the products listed - generally those not covered by **LIFETIME, 5-YEAR** or **18-MONTH**. No registration is required.
- 4) The **5-YEAR WARRANTY** is available generally for the products listed. No registration is required.
- 5) A **LIFETIME WARRANTY** is available for the products listed. It becomes effective when the accompanying **TURCK LIFETIME WARRANTY REGISTRATION** is completed and returned to **TURCK**.

GENERAL TERMS AND CONDITIONS FOR ALL WARRANTIES

- **12-MONTH STANDARD WARRANTY**
- **18-MONTH STANDARD WARRANTY**
- **24-MONTH STANDARD WARRANTY**
- **5-YEAR WARRANTY**
- **LIFETIME WARRANTY**

TURCK warrants the Products covered by the respective **WARRANTY AGREEMENTS** to be free from defects in material and workmanship under normal and proper usage for the respective time periods listed above from the date of shipment from **TURCK**. In addition, certain specific terms apply to the various **WARRANTIES**.

THESE EXPRESS WARRANTIES ARE IN LIEU OF AND EXCLUDE ALL OTHER REPRESENTATIONS MADE - BOTH EXPRESSED AND IMPLIED. THERE ARE NO WARRANTIES OF MERCHANTABILITY OR OF FITNESS FOR A PARTICULAR PURPOSE FOR PRODUCTS COVERED BY THESE TERMS AND CONDITIONS.

TURCK warrants that the goods sold are as described, but no promise, description, affirmation of fact, sample model or representation, oral or written shall be part of an order, unless set forth in these terms and conditions, or are in writing and signed by an authorized representative of **TURCK**. These **WARRANTIES** do not apply to any Product which has been subject to misuse, negligence, or accident - or to any Product which has been modified or repaired, improperly installed, altered, or disassembled -except according to **TURCK's** written instructions.

These **WARRANTIES** are subject to the following conditions:

- 1) These **WARRANTIES** are limited to the electronic and mechanical performance only, as expressly detailed in the Product specifications and **NOT** to cosmetic performance.
- 2) These **WARRANTIES** shall not apply to any cables attached to, or integrated with the Product. However, the **18-MONTH WARRANTY** shall apply to cables sold separately by **TURCK**.
- 3) These **WARRANTIES** shall not apply to any Products which are stored, or utilized, in harsh environmental or electrical conditions outside **TURCK's** written specifications.
- 4) The **WARRANTIES** are applicable only to Products shipped from **TURCK** subsequent to January 1, 1988.

ADDITIONAL SPECIFIC TERMS FOR -

(12-MONTH STANDARD WARRANTY) for Linear Displacement Transducers (EZ-Track) and RFID products, Draw Wire Assemblies / Slip Rings.

(18-MONTH STANDARD WARRANTY) FOR Q-TRACK INDUCTIVE SENSORS, ULTRASONIC SENSORS, FLOW SENSORS, PRESSURE SENSORS, TEMPERATURE SENSORS, CABLES AND ALL NON-SENSING PRODUCTS SOLD BY TURCK INC. INCLUDING MULTI-SAFE, MULTI-MODUL, MULTI-CART AND RELATED AMPLIFIER PRODUCTS, RELAYS AND TIMERS.

(24-MONTH STANDARD WARRANTY) FOR ENCODERS.

5-YEAR WARRANTY FOR INDUCTIVE AND CAPACITIVE PROXIMITY SENSORS: The periods covered for the above WARRANTIES and Products shall be 12 MONTHS, 18-MONTHS, 24-MONTHS and 5-YEARS, respectively, from the date of shipment from TURCK.

Warranty Terms and Conditions

ADDITIONAL SPECIFIC TERMS FOR - (continued)

LIFETIME WARRANTY (OPTIONAL - REGISTRATION REQUIRED) FOR INDUCTIVE, INDUCTIVE MAGNET OPERATED AND CAPACITIVE PROXIMITY SENSORS SOLD TO THE ORIGINAL PURCHASER FOR THE LIFETIME OF THE ORIGINAL APPLICATION.

The following terms apply to the LIFETIME WARRANTY in addition to the General Terms:

- 1) This WARRANTY shall be effective only when the LIFETIME WARRANTY REGISTRATION has been completed, signed by the End User and an authorized **TURCK** Representative or Distributor and has been received by **TURCK** no later than six (6) months after installation in the End User's Plant, or two (2) years from the date product was shipped from **TURCK**, whichever is sooner.
- 2) This warranty is available only to **TURCK's** authorized Representatives, Distributors and to the Original User. (The term "Original User" means that person, firm, or corporation which first uses the Product on a continuous basis in connection with the operation of a production line, piece of machinery, equipment, or similar device.) In the event the ownership of the product is transferred to a person, firm or corporation other than the Original User, this WARRANTY shall terminate.
- 3) This WARRANTY is applicable only to the Original Application. In the event the machinery, equipment, or production line to which the Product is connected, or on which it is installed, is substituted, changed, moved or replaced, the WARRANTY shall terminate.
- 4) This WARRANTY shall be valid only if the Product was purchased by the Original User from **TURCK**, or from an authorized **TURCK** Distributor, or was an integral part of a piece of machinery and equipment obtained by the Original user from an Original Equipment Manufacturer, which itself, was purchased directly from **TURCK** or from an authorized Distributor.

PURCHASER'S REMEDIES

This Remedy shall apply to all WARRANTIES. If a **TURCK** Distributor desires to make a WARRANTY Claim, the Distributor shall, if requested by **TURCK**, ship the Product to **TURCK's** factory in Minneapolis, Minnesota, postage or freight prepaid. If the User desires to make a WARRANTY Claim, they shall notify the authorized **TURCK** Distributor from whom it was purchased or, if such Distributor is unknown, shall notify **TURCK**. **TURCK** shall, at its option, take any of the following two courses of action for any products which **TURCK** determines are defective in materials or workmanship.

- 1) Repair or replace the Product and ship the Product to the Original Purchaser or to the authorized **TURCK** Distributor, postage or freight prepaid; or
- 2) Repay to the Original Purchaser that price paid by the Original Purchaser; provided that if the claim is made under the LIFETIME WARRANTY, and such Product is not then being manufactured by **TURCK**, then the amount to be repaid by **TURCK** to the Original Purchaser shall be reduced according to the following schedule:

<u>Number of Years Since Date of Purchase by Original Purchaser</u>	<u>Percent of Original Purchase Price To Be Paid by TURCK</u>
10	50%
15	25%
20	10%
More than 20	5%

PURCHASER'S REMEDIES SHALL BE LIMITED EXCLUSIVELY TO THE RIGHT OF REPLACEMENT, REPAIR OR REPAYMENT AS PROVIDED AND DOES NOT INCLUDE ANY LABOR COST OR REPLACEMENT AT ORIGINAL PURCHASER'S SITE. TURCK SHALL NOT BE LIABLE FOR ANY CONSEQUENTIAL DAMAGES RESULTING FROM ANY BREACH OF ANY WARRANTY, EXPRESSED OR IMPLIED, APPLICABLE TO THE PRODUCT, INCLUDING WITHOUT LIMITATION, ANY DAMAGES RESULTING FROM PROPERTY DAMAGE, PERSONAL INJURY OR BUSINESS INTERRUPTION.

CONSIDER SAFETY AND PROTECTION PRECAUTIONS

TURCK takes great care to design and build reliable and dependable products, however, some products can fail eventually. You must take precautions to design your equipment to prevent property damage and personal injury in the unlikely event of failure. As a matter of policy, **TURCK** does NOT recommend the installation of electronic controls as the sole device FOR THE PROTECTION OF PERSONNEL in connection with power driven presses, brakes, shears and similar equipment and, therefore, the customer should build in redundancy or dual control using approved safety devices for these applications.

GOVERNING LAW

The sale and purchase of Products covered hereby and all terms and conditions hereof shall be governed by the law of the State of Minnesota.

TURCK Instrumentation Warranty

Notes: