

**TURCK**  
*works*

Industrial  
Automation

**Sendix<sup>®</sup>**  
**Absolute  
Encoders**

*SSI & BiSS*  
*PROFIBUS<sup>®</sup> -DP*  
*CANopen*  
*CANlift*

**Kübler**  
*by* **TURCK**



[www.turck.com](http://www.turck.com)

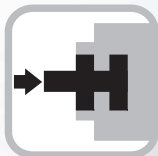

Safety-Lock™



High IP



Temperature



Magnetic  
Field Proof



Multiturn  
Gearbox



CANopen



## Sendix Absolute with Fieldbus Interface

Sendix®

Singleturn, Multiturn - with solid or hollow shaft  
Up to 17 Bit singleturn, 12 Bit multiturn

- Up-to-the-minute fieldbus profiles
- Rugged, proven Sendix design
- High speed
- Fast simple start-up thanks to
  - terminal bus cover
  - M12 connectors
  - diagnostic LEDs
  - bus programmable parameters

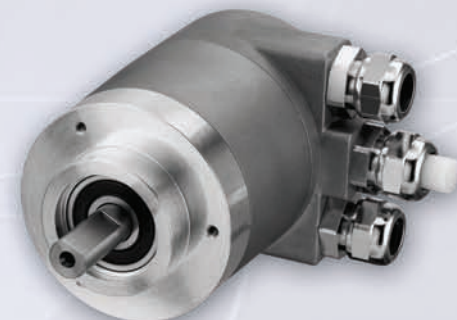
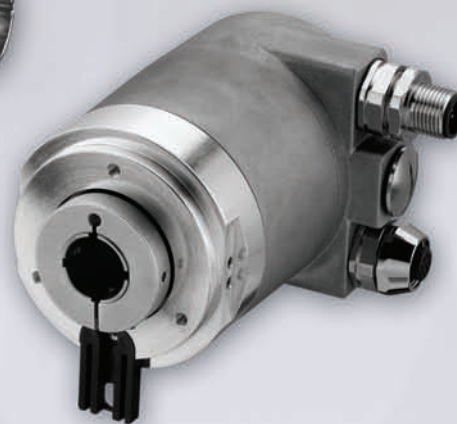

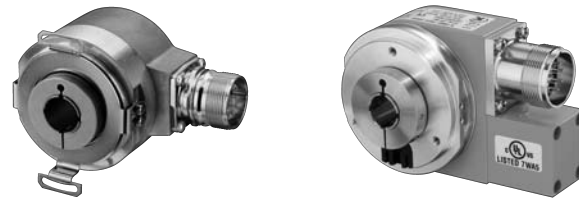

Geared vs. Electronic

Characteristics	Geared Multiturn NEW!	Existing Type Series Electronic Multiturn
For Use Near Strong Magnetic Fields, e.g for Geared Motors with Brake	<b>Very Good:</b> Sendix absolute encoders are highly resistant to magnetic fields. They succeed against other geared solutions, which to some extent use magnetic sensor technology. No battery required!	<b>Limited:</b> Consult factory.
Fast, High Precision Feedback	<b>Very Good:</b> Extremely fast, with feedback cycle times <math>< 20 \mu s</math>, additional incremental RS422 (TTL compatible) or SIN/COS track with 2048 pulses as option.	<b>Good:</b> With optional incremental RS422 tracks with 2048 pulses (TTL compatible).
Outdoor Applications Wet Weather	<b>Very Good:</b> Sendix absolute up to IP 67.	<b>Good:</b> Up to IP 65.
Very High or Low Temperatures e.g. Outdoor Applications	<b>Very Good:</b> Sendix absolute for a wide temperature range of -40°C up to +90°C.	<b>Good:</b> -20°C to +80°C.
Limited Space Large Hollow Shaft	<b>Good:</b> Sendix absolute is the first encoder on the market to offer a through hollow shaft up to 14 mm or blind hub shaft solutions up to 15 mm.	<b>Very Good:</b> Integrated ASIC and Intelligent Sensing Technology permits hollow shafts up to 28 mm or the slimmest multiturn encoder on the market, with an installation depth from only 42 mm with through hollow shaft.
Programmability	<b>Limited:</b> Single-turn, Resolution, Offset, Direction, configured by factory (configuration software in development).	<b>Very Good:</b> Fully scaleable with additional features like 4 programmable outputs (with <i>EzTurn</i> ).
Set Up	<b>Very Good:</b> SET-Push button and Status-LED ease start-up, additional DIR-and SET-Inputs.	<b>Good:</b> SET-and DIR-Inputs.

# Kübler by TURCK Absolute Encoders

Sendix® Singleturn					
		T8.5853	T8.5873	T8.5858	T8.5878
Interface	SSI	✓	✓		
	SSI + Incremental Track	✓	✓		
	SSI + SIN/COS Track	✓	✓		
	BISS	✓	✓		
	BISS + Incremental Track	✓	✓		
	BISS + SIN/COS Track	✓	✓		
	Parallel				
	Analogue Output				
	PROFIBUS-DP			✓	✓
CANopen			✓	✓	
Mechanical Characteristics	Shaft Max.	10 mm	-	10 mm	-
	Blind Hub Shaft Max.	-	15 mm	-	15mm
	Through Hollow Shaft	-	14 mm	-	-
Performance Characteristics	Max. Speed RPM	12000	9000	9000	9000
	Resolution Max. in Bit	17	17	16	16
	Programmable			✓	✓
	Set Key (optional)	✓	✓	✓	✓
	Status LED (optional)	✓	✓	✓	✓
	Safety Lock™	✓	✓	✓	✓
	Temp. Min.	-40°C	-40°C	-40°C	-40°C
	Temp. Max.	+90°C	+90°C	+80°C	+80°C
IP Max.	67	67	67	67	

Sendix® Multiturn					
		T8.5863	T8.5883	T8.5868	T8.5888
Interface	SSI	✓	✓		
	SSI + Incremental Track	✓	✓		
	SSI+ SIN/COS Track	✓	✓		
	BISS	✓	✓		
	BISS + Incremental Track	✓	✓		
	BISS+ SIN/COS Track	✓	✓		
	RS485				
	PROFIBUS DP			✓	✓
	CANopen			✓	✓
CANlift			✓	✓	
Mechanical Characteristics	Shaft Max.	10 mm	-	10 mm	-
	Blind Hub Shaft	-	15 mm	-	15 mm-
	Through Hollow Shaft	-	14 mm	-	-
Performance Characteristics	Max Speed RPM	12000	9000	9000	9000
	Mechanical Gears	✓	✓	✓	✓
	Non-contact Gears				
	Resolution Max. in Bit	29	29	28	28
	Programmable			✓	✓
	Control Output	✓	✓	✓	✓
	Set Key (optional)	✓	✓	✓	✓
	Status LED (optional)	✓	✓	✓	✓
	Safety Lock™	✓	✓	✓	✓
	Temp. Min.	-40°C	-40°C	-40°C	-40°C
Temp. Max.	+90°C	+90°C	+80°C	+80°C	
IP Max.	67	67	67	67	

✓ = available as standard product

Introduction . . . . .	1	
Singleturn Type T8.5853, SSI, BiSS . . . . .	5	
Singleturn Type T8.5858 CANopen . . . . .	11	
Singleturn Type T8.5858 PROFIBUS <sup>®</sup> -DP . . . . .	18	
Singleturn Type T8.5873, SSI, BiSS . . . . .	23	
Singleturn Type T8.5878 CANopen . . . . .	29	
Singleturn Type T8.5878 PROFIBUS -DP . . . . .	36	
Multiturn Type T8.5863 SSI, BiSS . . . . .	41	
Multiturn Type T8.5868 CANopen/CANlift . . . . .	47	
Multiturn Type T8.5868 PROFIBUS -DP . . . . .	54	
Multiturn Type T8.5883 SSI, BiSS . . . . .	59	
Multiturn Type T8.5888 CANopen/CANlift . . . . .	65	
Multiturn Type T8.5888 PROFIBUS -DP . . . . .	72	
Cordsets . . . . .	77	

# Kübler by TURCK Absolute Encoders

**Sendix** Absolute, Singleturn Shafted Type T8.5853

SSI, BiSS

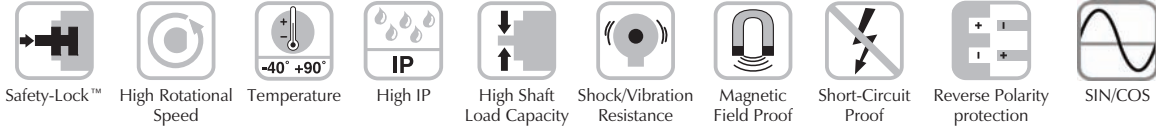

**T8. 5853. X X X X. XXXX.**

### Flange

- 1 = Clamping Flange Ø58 mm, IP 65
- 2 = Servo Flange Ø58 mm, IP 65
- 3 = Clamping Flange Ø58 mm, IP 67
- 4 = Servo Flange Ø58 mm, IP 67
- 5 = Square Flange 2.5"/63.5 mm, IP 65
- 6 = Servo Flange 2.5"/63.5 mm, IP65
- 7 = Square Flange 2.5"/63.5 mm, IP 67
- 8 = Servo Flange 2.5"/63.5 mm, IP67

### Shaft

- 1 = Ø6 mm x 10 mm
- 2 = Ø10 mm x 20 mm
- 3 = Ø1/4" mm x 7/8"
- 4 = Ø3/8" x 7/8"

### Input / Output Circuit

- 1 = 5 VDC / SSI or BiSS interface
- 2 = 10-30 VDC / SSI or BiSS interface
- 3 = 5 VDC / SSI or BiSS interface, and 2048 ppr SinCos
- 4 = 10-30 VDC / SSI or BiSS interface, and 2048 ppr SinCos(M23)
- 5 = 5 VDC / SSI or BiSS interface, with supply voltage monitoring output
- 6 = 5 VDC / SSI or BiSS interface, and 2048 ppr SinCos, with supply voltage monitoring output
- 7 = 5 VDC / SSI or BiSS and 2048 ppr-incremental track RS422 (TTL-comp.)
- 8 = 10-30 VDC / SSI or BiSS and 2048 ppr-incremental track RS422 (TTL-comp.)
- 9 = 5 VDC / SSI or BiSS and 2048 incremental track RS422 (TTL-comp.), with supply voltage monitoring output

- <sup>1)</sup> Status LED internally monitors encoder parameters such as; sensor condition, temperature, under and over voltage.
- <sup>2)</sup> Preset value, factory-programmable.
- <sup>3)</sup> Set and Direction are physical inputs for setting: 0 position (or any factory predefined value); controls rotation of shaft (CW/CCW) for increasing counts. Status output is discrete output linked to the LED status indicator.
- <sup>4)</sup> The Set button and Status LED are located on the rear of the encoder cover. Same functionality as SET control input, protected against accidental activation, can only be pushed in with the tip of a ballpoint pen or similar.

### Options <sup>1)</sup>

- 1 = No option
- 2 = Status LED
- 3 = Set button and status LED <sup>4)</sup>

### Input / Output <sup>3)</sup>

- 2 = SET, DIR Inputs and additional status output

### Resolution <sup>2)</sup>

- A = 10 bit
- 1 = 11 bit
- 2 = 12 bit
- 3 = 13 bit
- 4 = 14 bit
- 7 = 17 bit

### Code

- B = SSI, binary
- C = BiSS, binary
- G = SSI, gray

### Connection Type

- 1 = Axial cable, (PVC, 1 meter)
- 2 = Radial cable (PVC, 1 meter)
- 3 = Axial 12-pin, M23 (**multifast**<sup>®</sup>)
- 4 = Radial 12-pin, M23 (**multifast**<sup>®</sup>)
- 5 = Axial M12, 8-pin (**eurofast**<sup>®</sup>)
- 6 = Radial M12, 8-pin (**eurofast**<sup>®</sup>)

## Features / Benefits

- Update rate of 100 KHz for real time transmission
- BiSS clock rate to 10Mhz
- Sinusoidal or square wave incremental signals (optional)
- SSI clock rate to 2Mhz
- Captive bearings
- Wide temperature range

**Sendix® Absolute, Singleturn Shafted Type T8.5853 Specifications** **SSI, BiSS**

**Mechanical Characteristics:**

- Max. Speed w/o Shaft Sealing (IP 65) . . . . 12000 RPM (Peak), 10000 RPM (Continuous) (up to 70°C)
- Max. Speed w/o Shaft Sealing (IP 65) . . . . 8000 RPM (Peak), 5000 RPM (Continuous) (up to Tmax)
- Max. Speed w/Shaft Sealing (IP 67) . . . . 11000 RPM (Peak), 9000 RPM (Continuous) (up to 70°C)
- Max. Speed w/Shaft Sealing (IP 67) . . . . 8000 RPM (Peak), 5000 RPM (Continuous) (up to Tmax)
- Protection Rating . . . . . IP 65 (IP 67 with Shaft Seal)
- Operating Temperature<sup>1)</sup> . . . . . -40° to +90°C (-40° to +194°F)
- Shock Resistance . . . . . Up to 250 g
- Vibration Resistance . . . . . Up to 100 g, 55-2000 Hz
- Humidity . . . . . 98% Relative, Non-Condensing
- Weight . . . . . Appr. 0.77lbs
- Materials . . . . . Shaft: Stainless Steel; Flange: Aluminum, Housing: Die-Cast Zinc, Cable: PVC
- Starting Torque w/o Shaft Sealing (IP 65). . . <0.089 in lbf
- Starting Torque w/Shaft Sealing (IP 67). . . <0.443 in lbf

**General Electrical Characteristics:**

Interface . . . . .	<b>BiSS, SSI / 5 VDC</b> . . . . .	<b>BiSS, SSI / 10-30 VDC</b>
Output Driver . . . . .	RS 485 (Transceiver Type) . . . . .	RS 485 (Transceiver Type)
Current Consumption (Typ./Max.) . . . . .	70 mA @ 5 VDC . . . . .	20 mA @ 24 VDC
Load / Channel (Max.) . . . . .	±20 mA . . . . .	±20 mA
Signal Level High (Typ.) . . . . .	3.8 V . . . . .	3.8 V
Signal Level Low (Typ.) . . . . .	1.3 V . . . . .	1.3 V
Short-Circuit Proof <sup>2)</sup> . . . . .	Yes . . . . .	Yes
Reverse Polarity Protection . . . . .	No. . . . .	Yes

**Interface Characteristics SSI:**

- singleturn Resolution . . . . . 10-14 Bits and 17 Bits <sup>3)</sup>
- Code . . . . . Binary or Gray
- SSI Clock Rate. . . . . ≤14 bits: 50 kHz - 2 MHz
- Monoflop Time . . . . . ≥15 μs <sup>3)</sup>
- Time Jitter (Data Request to Position Latch) <1μs up to 14 bits  
≤4 μs at 15-17 bits
- Status and Parity Bit . . . . . Optional on Request

**Note:** If clock starts cycling within monoflop time a second data transfer starts with the same data, double clocking is useful for data verification. If clock starts cycling after monoflop time the data transfer starts with updated values. Max. update rate is depending on clock speed, data length and monoflop-time.

<sup>1)</sup> Cable Versions: -30° to +75°C (-22° to 167°F).  
<sup>2)</sup> Short-circuit to 0 V or to output, one channel at a time, supply voltage correctly applied.  
<sup>3)</sup> Other options upon request.

5853 SSI, BiSS

### Interface Characteristics BiSS:

<b>Singleturn Resolution</b> . . . . .	10-14 Bits and 17 Bits, Customer Programmable <sup>1)</sup>
<b>Code</b> . . . . .	Binary
<b>Interfaces</b> . . . . .	RS 485
<b>Clock Rate</b> . . . . .	Up to 10 MHz
<b>Max. Update Rate</b> . . . . .	<10 µs, Depending on Clock Speed and Data Length
<b>Time Jitter (data request to position latch)</b> . . . . .	≤1 µs

**Note:** Bidirectional, programmable parameters are: resolution, code, direction, alarms and warnings.  
Multicycle data output, e.g. for temperature.  
CRC data verification.

### SET (Zero or Defined Value) and DIRection (cw/ccw) Control Inputs:

<b>Input Characteristic</b> . . . . .	High Active
<b>Receiver Type</b> . . . . .	Comparator
<b>Signal Level High</b> . . . . .	Min. 60% of V+ (Supply Voltage), Max: V+
<b>Signal Level Low</b> . . . . .	Max. 25% of V+
<b>Input Current</b> . . . . .	≤0.5 mA
<b>Min. Pulse Duration (SET)</b> . . . . .	10 ms
<b>Timeout After SET Input</b> . . . . .	14 ms
<b>Reaction Time (DIR Input)</b> . . . . .	1 ms

### Status Output:

<b>Output Driver</b> . . . . .	Open Collector, Internal Pull Up Resistor 22 kΩ
<b>Permissible Load</b> . . . . .	≤20 mA
<b>Signal Level High</b> . . . . .	V+
<b>Signal Level Low</b> . . . . .	<1 V
<b>Active At</b> . . . . .	Low

Optical sensor path faulty (code error, LED error), low voltage and overtemperature.

<sup>1)</sup> Other options upon request.



**Sendix® Absolute, Singleturn Shafted Type T8.5853 Specifications** **SSI, BiSS**

**Status LED (Red, Option):**

LED on at . . . . . Optical sensor path faulty (code error, LED error), low voltage and overtemperature

**SET Control Button (Zero or Defined Value, Option):**

Same functionality as SET control input, protected against accidental activation, can only be pushed in with the tip of a ballpoint pen or similar.

**Option Incremental Output (A/B), 2048 ppr:**

	Sin/Cos	RS422 (TTL Compatible)
-3dB Frequency . . . . .	400 kHz . . . . .	400 kHz
Signal Level . . . . .	1 Vpp (± 20%) . . . . .	High: min 2.5 V Low: max. 0.5 V
Short Circuit Proof <sup>1)</sup> . . . . .	Yes . . . . .	Yes

<sup>1)</sup> Short-circuit to 0 V or to output, one channel at a time, supply voltage correctly applied.

5853 SSI, BiSS

# Kübler by TURCK

## Absolute Encoders

### Sendix® Absolute, Singleturn Shafted Type T8.5853 Specifications

SSI, BiSS

#### Pinouts Notes 1), 2), 3)

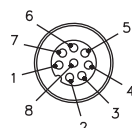
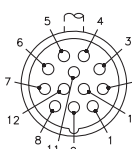
Male Encoder View	Mating Cordset
<p><b>M12 Pinout</b></p> 	E-RKS 8T-264-*
<p><b>M23 Pinout (12-Pin)</b></p>  <p>CCW</p>	E-CKM 12-1687-*/A

- 1) See cable section for additional options.
- 2) "S" denotes shield tied to coupling nut.
- 3) \* = length in meters, available in 0.1 meter increments  $\geq 0.2$  meters.

### Standard Wiring / Pin Configuration

#### Output Circuit 1 or 2 and (2 Control Inputs, 1 Status Output)

(Connection 1,2,3 or 4)

Output	Common	+V	+Clock	-Clock	+Data	-Data	ST	DIR	Status	NC	NC	NC	PE
M23 Pin	1	2	3	4	5	6	7	8	9	10	11	12	PH
Color	WH	BN	GN	YE	GY	PK	BU	RD	BK	-	-	-	Shield

#### Output Circuit 5 and (2 Control Inputs, 1 Status Output, Voltage Monitor Outputs)

(Connection 1,2,3 or 4)

Output	Common	+V	+Clock	-Clock	+Data	-Data	ST	DIR	Status	NC	0 V Sens	+Ub Sens	PE
M23 Pin	1	2	3	4	5	6	7	8	9	10	11	12	PH
Color	WH	BN	GN	YE	GY	PK	BU	RD	BK	-	GY/PK	RD/BU	Shield

#### Output Circuit 3, 4, 7 or 8, and (2 Control Inputs or Incremental Track, Sine/Cosine)

(Connection 1,2,3 or 4)

Output	Common	+V	+Clock	-Clock	+Data	-Data	ST	DIR	Sin A	Sin inv A-	Cos B	Cos inv B-	PE
M23 Pin	1	2	3	4	5	6	7	8	9	10	11	12	PH
Color	WH	BN	GN	YE	GY	PK	BU	RD	BK	VT	GY/PK	RD/BU	Shield

#### Output Circuit 6 or 9 and (Sine/Cosine, or Incremental Monitor, Voltage Outputs)

(Connection 1,2,3 or 4)

Output	Common	+V	+Clock	-Clock	+Data	-Data	Sin A	Sin inv A-	Cos B	Cos inv B-	0 V Sens	V+ Sens	PE
M23 Pin	1	2	3	4	5	6	7	8	9	10	11	12	PH
Color	WH	BN	GN	YE	GY	PK	BU	RD	BK	VT	GY/PK	RD/BU	Shield

#### Output Circuit 1 or 2 and (2 Control Inputs)

(Connection 5 or 6)

Output	Common	+V	+Clock	-Clock	+Data	-Data	SET	DIR	Shield/PE
M12 Pin	1	2	3	4	5	6	7	8	PH

**Sendix® Absolute, Singleturn Shafted Type T8.5853 Dimensions** **SSI, BiSS**

**T8.5853 Square Flanges 5 & 7  
Cable Connection 1 & 2**

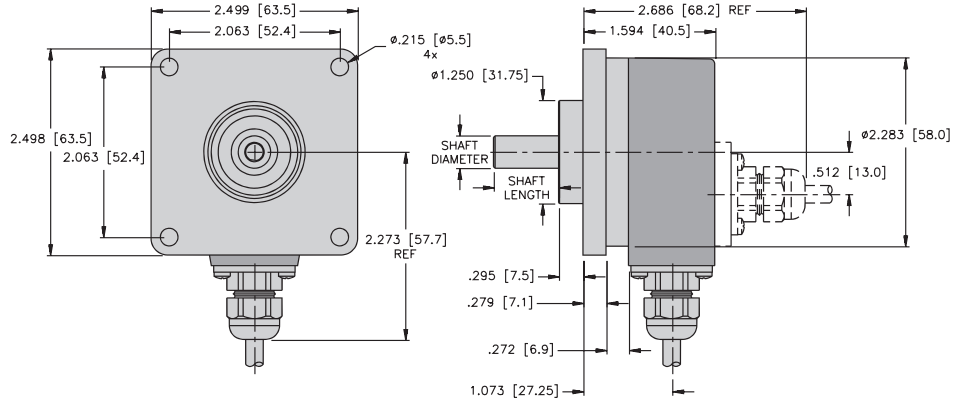

**T8.5853 Clamping Flanges 1 & 3  
M23 Connection 3 & 4**

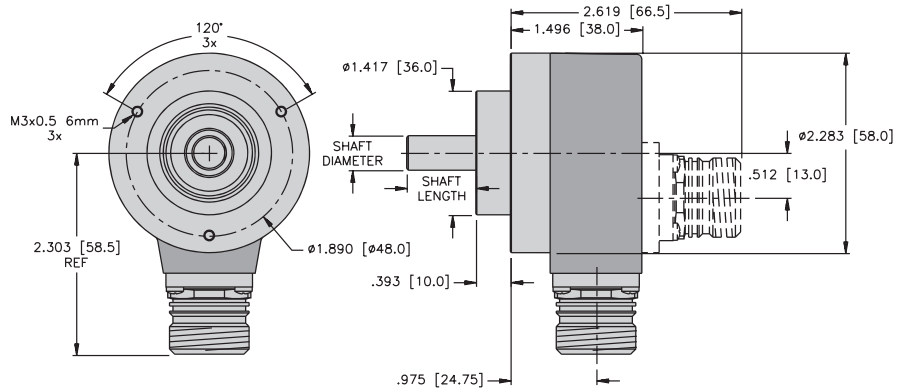

**T8.5853 Servo Flanges 2 & 4  
M12 Connection 5 & 6**

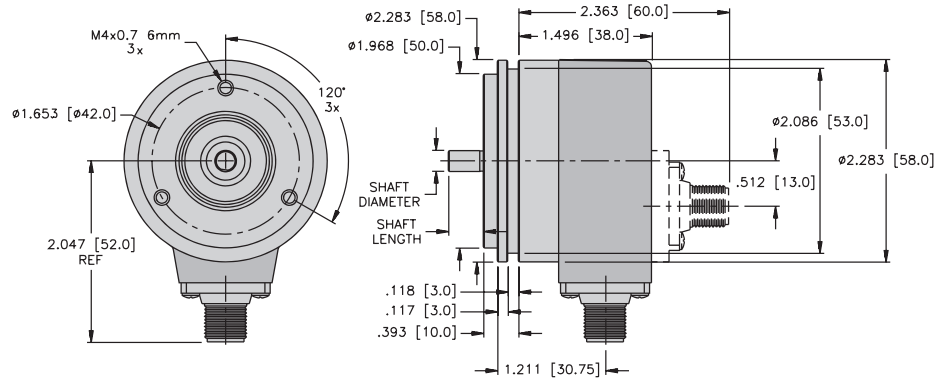

5853 SSI, BiSS

# Kübler by TURCK Absolute Encoders

**Sendix® Absolute, Singleturn Shafted Type T8.5858**

**CANopen**

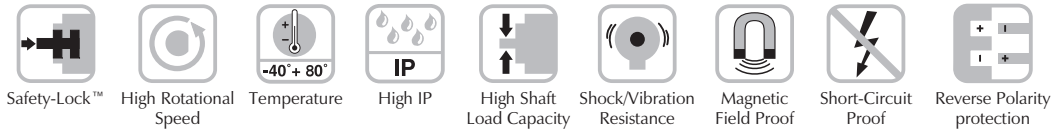

**T8. 5858. X X X X. XX1X.**

### Flange

- 1 = Clamping Flange Ø58 mm, IP 65
- 2 = Servo Flange Ø58 mm, IP 65
- 3 = Clamping Flange Ø58 mm, IP 67
- 4 = Servo Flange Ø58 mm, IP 67
- 5 = Square Flange 2.5"/63.5 mm, IP 65
- 6 = Servo Flange 2.5"/63.5 mm, IP65
- 7 = Square Flange 2.5"/63.5 mm, IP 67
- 8 = Servo Flange 2.5"/63.5 mm, IP67

### Shaft

- 1 = Ø6 mm x 10 mm
- 2 = Ø10 mm x 20 mm
- 3 = Ø1/4" mm x 7/8"
- 4 = Ø3/8" x 7/8"

### Input / Output Circuit

- 2 = 10-30 VDC CANopen DS 301 V4.02

### Options

- 2 = No option
- 3 = Set button

### Fieldbus Profile<sup>1)</sup>

- 21 = CANopen Encoder-Profile DS 406 V3.1

### Connection Type

- 1 = Removable bus terminal cover, with radial screwed cable passage
- 2 = Removable bus terminal cover with 2 - M12 **eurofast**® connectors
- A = Fixed connection without bus terminal cover with radial cable (PVC 2 meter)<sup>2)</sup>
- E = Fixed connection without bus terminal cover with 1 - M12 **eurofast** radial connector<sup>2)</sup>
- F = Fixed connection without bus terminal cover with 2 - M12 **eurofast** radial connectors<sup>2)</sup>
- I = Fixed connection without bus terminal cover with 1 - M23 **multifast**® radial connector<sup>2)</sup>
- J = Fixed connection without bus terminal cover with 2 - M23 **multifast** radial connectors<sup>2)</sup>

<sup>1)</sup> CANopen parameters can also be factory preset. Please consult factory.  
<sup>2)</sup> Baud rate, address, and termination can not be set through dip-switches and must be configured via the bus program.

## Features / Benefits

- Captive bearings
- Wide temperature range
- Many connector styles; M12, fixed cover, removable cover, etc
- Heavy duty diecast cover
- Compact size
- High speed integrated OptoASIC
- High IP rating

**Sendix® Absolute, Singleturn Shafted Type T8.5858 Specifications** **CANopen**

**Mechanical:**

- Max. Speed w/o Shaft Sealing (IP 65)** . . . . 9000 RPM (Peak), 7000 RPM (Continuous) (up to 70°C)
- Max. Speed w/o Shaft Sealing (IP 65)** . . . . 7000 RPM (Peak), 4000 RPM (Continuous) (up to Tmax)
- Max. Speed w/Shaft Sealing (IP 67)** . . . . 8000 RPM (Peak), 6000 RPM (Continuous) (up to 70°C)
- Max. Speed w/Shaft Sealing (IP 67)** . . . . 6000 RPM (Peak), 3000 RPM (Continuous) (up to Tmax)
- Protection Rating** . . . . . IP 65 (IP 67 with Shaft Seal)
- Operating Temperature**<sup>1)</sup> . . . . . -40° to +80°C (-40° to 176°F)
- Shock Resistance** . . . . . Up to 250 g
- Vibration Resistance** . . . . . Up to 100 g, 55-2000 Hz
- Humidity** . . . . . 98% Relative, Non-Condensing
- Weight** . . . . . Appr. 1.67 lbs with Bus terminal; Appr.1.10 lbs with Fixed Connection
- Materials** . . . . . Shaft: Stainless Steel; Flange: Aluminum, Housing: Die-Cast Zinc, Cable: PVC
- Starting Torque w/o Shaft sealing (IP 65)** . . 1.42 oz.in.(<0.01Nm)
- Starting Torque w/Shaft sealing (IP 67)** . . . 7.08 oz.in.(<0.05Nm)

<sup>1)</sup> Cable versions: -30° to +75°C (-22° to 167°F).

**General Electrical Characteristics:**

- Supply Voltage** . . . . . 10-30 VDC
  - Current Consumption (w/o Output Load)** . Max. 60 mA, 24 VDC
  - Reverse Polarity**
  - Protection at Power Supply** . . . . . Yes
- Conforms to CE Requirements Acc. to EN 61000-6-1, EN61000-6-4 and EN 61000-6-3

**Interface Characteristics CANopen:**

- Singleturn Resolution (Max., Scaleable)** . . 1-65536 (16 Bits), Default Scale Value is Set to 8192 (13 Bits)
- Code** . . . . . Binary
- Interface** . . . . . CAN High Speed According ISO 11898, Basic - and Full-CAN, CAN Specification 2.0 B

**General Information About CANopen:**

The CANopen encoders of the 5858 series support the latest CANopen communication profile according to DS 301 V4.02 . In addition, device-specific profiles like the encoder profile DS 406 V3.1 are available. The following operating modes may be selected: Polled Mode, Cyclic Mode, Sync Mode and a High Resolution Sync Protocol. Additionally, scale factors, preset values, limit switch values and many other parameters can be programmed via the CANBus. When switching the device on, all parameters, which have been saved on an EEPROM to protect them against power failure, are reloaded. The following output values may be combined by PDO mapping: position, speed, acceleration, and status.

5858 CANopen

## CANopen Communication Profile DS 301 V4.02:

Among others, the following functionality is integrated:

Class 2 Functionality

- NMT slave
- Heartbeat protocol
- High resolution sync protocol identity object
- Error behavior object
- Variable PDO mapping self-start programmable (power on to operational), 3 sending PDO's
- 1 Receiving PDO for synchronous preset operation with minimal jitter\
- Node address, baud rate and CANbus
- Programmable termination

## CANopen Encoder Profile DS 406 V3.1:

The following parameters can be programmed:

- Event mode
- Units for speed selectable (steps/sec or RPM)
- Factor for speed calculation (e.g. measuring wheel periphery) Integration time for speed value of 1-32
- 2 work areas with 2 upper and lower limits and the corresponding output states
- Variable PDO mapping for position, speed, acceleration, work area, status
- Extended failure management for position sensing with integrated temperature control
- User interface with visual display of bus and failure status - 3 LED's
- Optional - 32 CAM's programmable
- Customer-specific memory - 16 Bytes

**Note:** All profiles stated here: Key-features.

The object 6003h "Preset" is assigned to an integrated key, accessible from the outside "Watchdog-controlled" device.

## SET Control Button (Zero or Defined Value, Option):

Protected against accidental activation, can only be pushed in with the tip of a ballpoint pen or similar.

## Diagnostic LED (yellow):

**LED on at** . . . . . Optical sensor path faulty (code error, LED error), low voltage and overtemperature

## Protocol

**Protocol** . . . . . CANopen Profile DS 406 V3.1 with Manufacturer-Specific Add-Ons

**Baud Rate** . . . . . 10-1000 kbit/s (Set by DIP Switches/Software Configurable)

**Node Address** . . . . . 1-127 (Set by Rotary Switches/Software Configurable)

**Termination Switchable** . . . . . Set by DIP Switches, Software Configurable

Price conscience encoders are available with optional connectors or cable connections in place of the costlier removable terminal box versions. Additionally, these encoders do not have user accessible DIP switches and require the user to program the address and baud rate through the software.

The models with the terminal cover include an integrated T-shaped coupler with the bus and power connections utilizing simple M12 connectors. The device address is set with two rotary switches while a bank of DIP switches set the baud rate and also allows the connection of a termination resistor.

Finally, all versions include three LED's located on the rear of the housing to indicate the status of the CAN bus as well as the status of the internal diagnostics.

**Sendix® Absolute, Singleturn Shafted Type T8.5858 Specifications** **CANopen**

**Pinouts** Notes 1), 2), 3)

A Male Encoder View	B Female Encoder View	C Male Encoder View
CCW		
<b>Bus In and Out M23</b>	<b>Bus Out M12 Pinout</b>	<b>Bus In M12 Pinout</b>
<b>Mating Cordset</b>	<b>Mating Cordset</b>	<b>Mating Cordset</b>
Consult Factory	RSC 572-*M	RKC 572-*M

- 1) See cable section for additional options.
- 2) "S" denotes shield tied to coupling nut.
- 3) \* = length in meters, available in 0.1 meter increments ≥0.2 meters.

5858 CANopen

**Standard Wiring / Pin Configuration**

Bus Terminal Cover with Terminal Box

(Connection 1)

Direction	OUT					IN				
Signal:	CAN Ground	CAN_Low (-)	CAN_High (+)	0 VOLT Power Supply	+VOLT Power Supply	0 VOLT Power Supply	+VOLT Power Supply	CAN_Low (-)	CAN_High (+)	CAN Ground
Abbreviation:	CG	CL	CH	0 V	+V	0 V	+V	CL	CH	CG

Cable Connection

(Connection A)

Direction	IN				
Signal:	0 VOLT Power Supply	+VOLT Power Supply	CAN_Low (-)	CAN_High (+)	CAN Ground
Abbreviation:	0 V	+V	CL	CH	CG
Cable Color	BK	RD	BL	WH	GY

M23 Connector or M12 Connector

(Connection I) (Connection E)

Direction	IN					Pinout
Signal:	0 VOLT Power Supply	+VOLT Power Supply	CAN_Low (-)	CAN_High (+)	CAN Ground	
Abbreviation:	0 V	+V	CL	CH	CG	
M23 PIN Assignment:	10	12	2	7	3	A
M12 PIN Assignment:	3	2	5	4	1	C

Bus Terminal Cover with 2 - M12, 2 - M12, 2 - M23

(Connection 2) (Connection F) (Connection J)

Direction	OUT					Pinout	IN					Pinout
Signal:	CAN Ground	CAN_Low (-)	CAN_High (+)	0 VOLT Power Supply	+VOLT Power Supply		0 VOLT Power Supply	+VOLT Power Supply	CAN_Low (-)	CAN_High (+)	CAN Ground	
Abbreviation:	CG	CL	CH	0 V	+V		0 V	+V	CL	CH	CG	
M23 PIN Assignment:	3	2	7	10	12	A	10	12	2	7	3	A
M12 PIN Assignment:	1	5	4	3	2	B	3	2	5	4	1	C

**T8.5858 Servo Flanges 2 & 4  
Cable Connection 1**

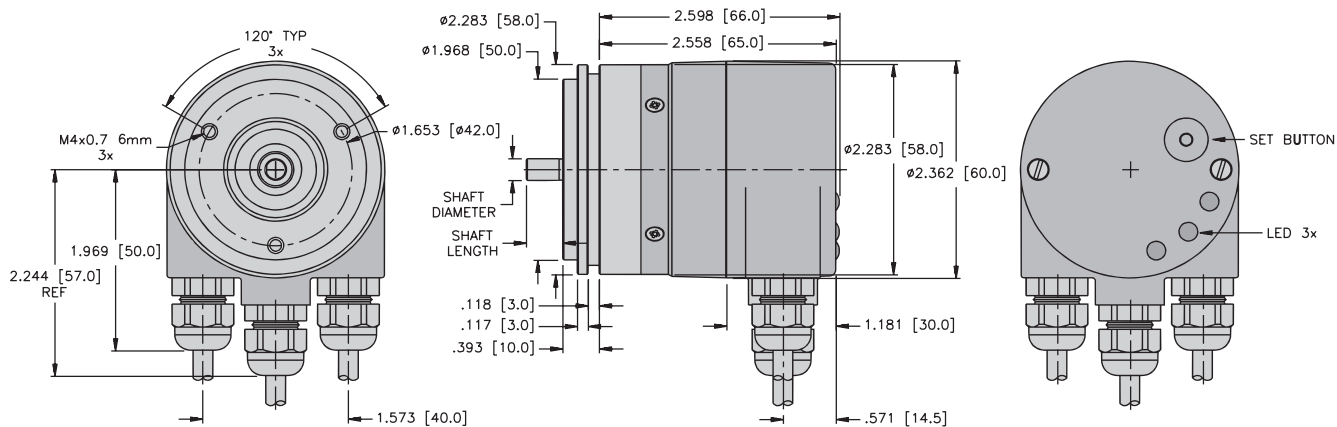

**T8.5858 Clamping Flanges 1 & 3  
M12 Connection 2**

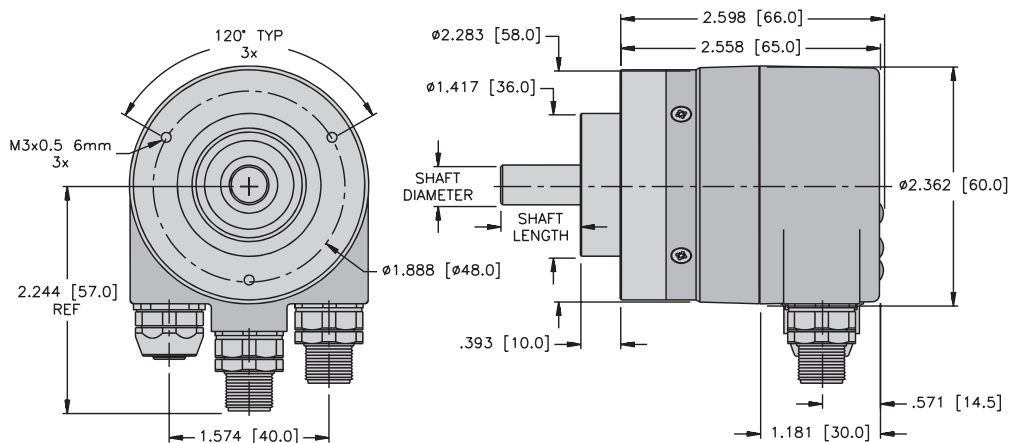

**T8.5858 Clamping Flanges 1 & 3  
Cable Connection A**

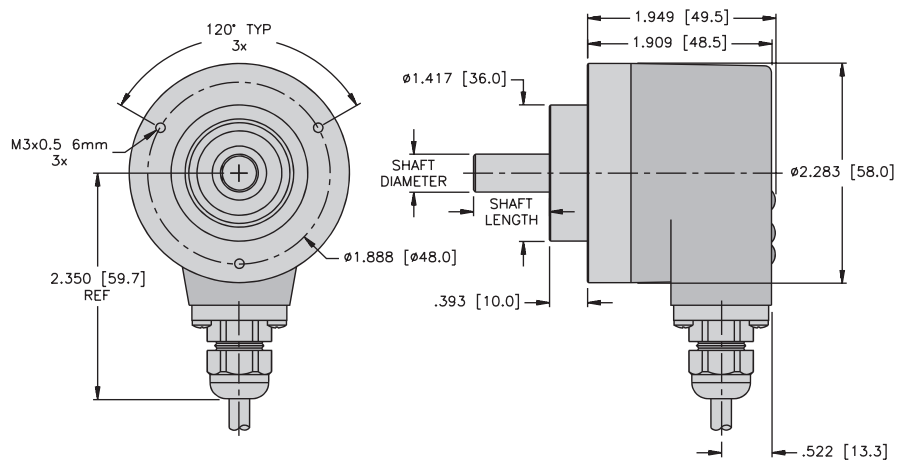



Sendix® Absolute, Singleturn Shafted Type T8.5858 Dimensions CANopen

**T8.5858 Clamping Flanges 1 & 3  
M12 Connection E**

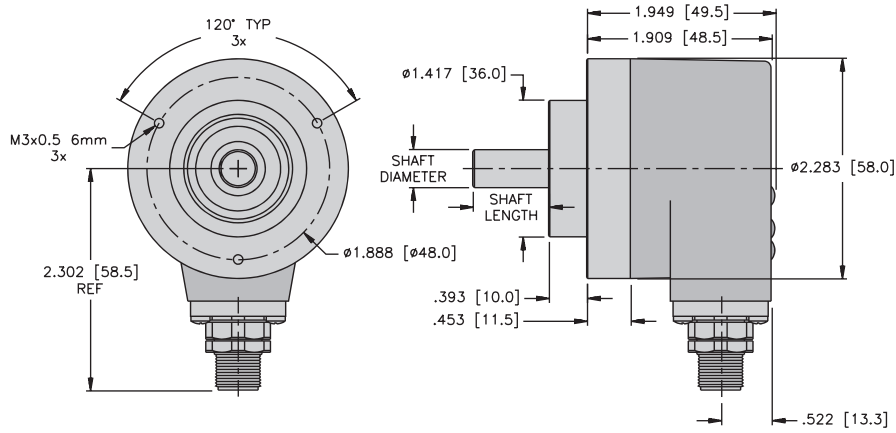

**T8.5858 Clamping Flanges 1 & 3  
M12 Connection F**

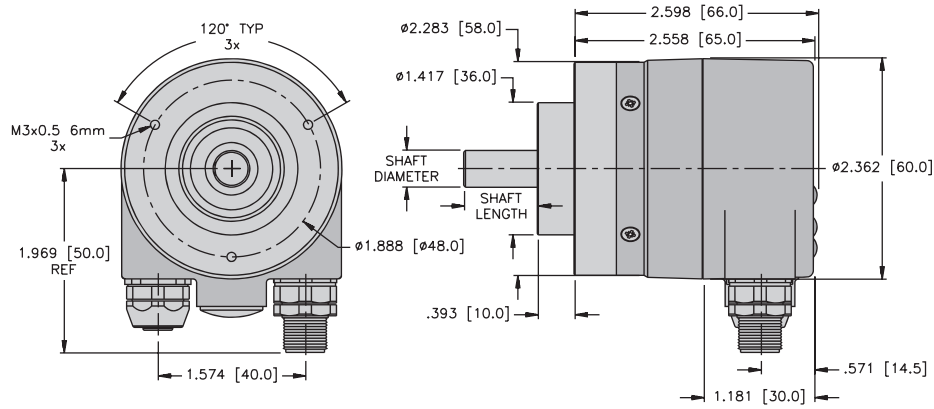

**T8.5858 Servo Flanges 2 & 4  
M23 Connection I**

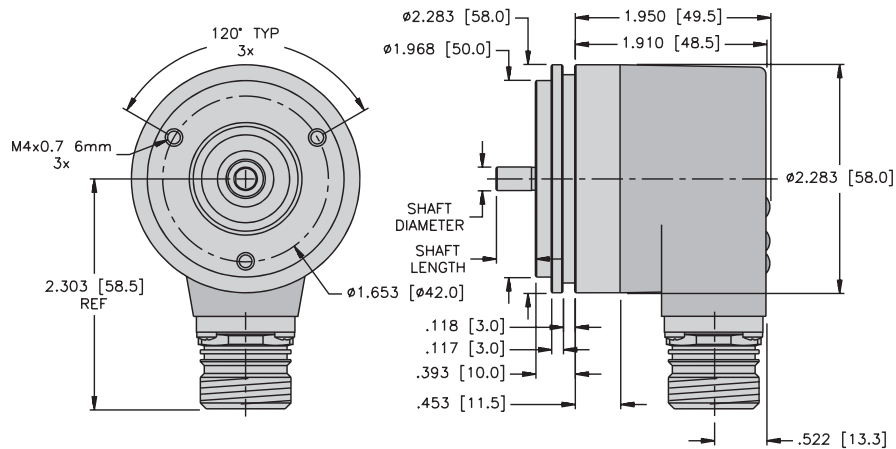





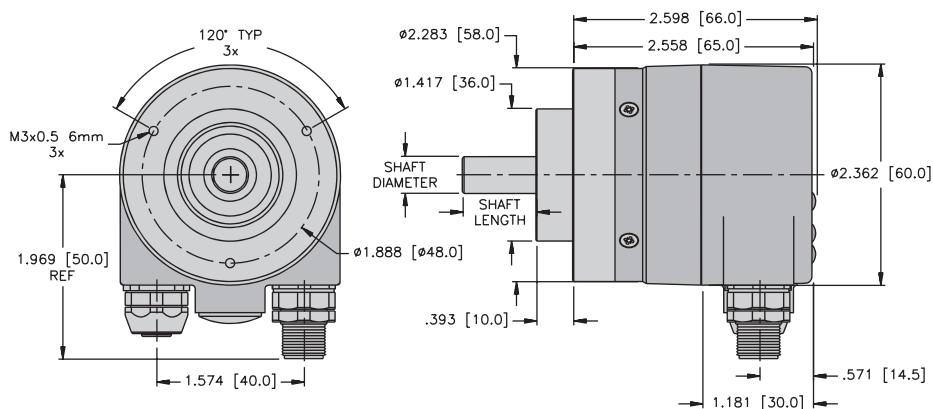



5858 CANopen

T8.5858 Square Flanges 5 & 7  
M23 Connection J



**Sendix® Absolute, Singleturn Shafted Type T8.5858 PROFIBUS®-DP**



-   
Safety-Lock™
-   
High Rotational  
Speed
-   
Temperature  
-40° + 80°
-   
High IP
-   
High Shaft  
Load Capacity
-   
Shock/Vibration  
Resistance
-   
Magnetic  
Field Proof
-   
Short-Circuit  
Proof
-   
Reverse Polarity  
protection

**T8. 5858. X X X X. XX1X.**

**Flange**

- 1 = Clamping Flange Ø58 mm, IP 65
- 2 = Servo Flange Ø58 mm, IP 65
- 3 = Clamping Flange Ø58 mm, IP 67
- 4 = Servo Flange Ø58 mm, IP 67
- 5 = Square Flange 2.5"/63.5 mm, IP 65
- 6 = Servo Flange 2.5"/63.5 mm, IP 65
- 7 = Square Flange 2.5"/63.5 mm, IP 67
- 8 = Servo Flange 2.5"/63.5 mm, IP 67

**Shaft**

- 1 = Ø6 mm x 10 mm
- 2 = Ø10 mm x 20 mm
- 3 = Ø1/4" mm x 7/8"
- 4 = Ø3/8" x 7/8"

**Input / Output Circuit**

- 3 = 10-30 VDC PROFIBUS-DP V0 Encoder Profile V 1

**Options**

- 2 = No option
- 3 = Set button

**Fieldbus Profile**

- 31 = PROFIBUS-DP-V0  
Encoder profile class 2

**Connection Type**

- 1 = Removable bus terminal cover,  
with radial screwed cable passage
- 2 = Removable bus terminal cover  
with 3 - M12 **euromast**® connectors

5858 PROFIBUS® -DP

**Features / Benefits**

- Captive bearings
- Wide temperature range
- Removable terminal box with M12 connector and cable versions
- Heavy duty diecast cover
- Compact size
- High speed to integrated OptoASIC
- High IP rating

## Mechanical:

<b>Max. Speed w/o Shaft Sealing (IP 65)</b>	. . . . . 9000 RPM (Peak), 7000 RPM (Continuous) (up to 70°C)
<b>Max. Speed w/o Shaft Sealing (IP 65)</b>	. . . . . 7000 RPM (Peak), 4000 RPM (Continuous) (up to Tmax)
<b>Max. Speed w/Shaft Sealing (IP 67)</b>	. . . . . 8000 RPM (Peak), 6000 RPM (Continuous) (up to 70°C)
<b>Max. Speed w/Shaft Sealing (IP 67)</b>	. . . . . 6000 RPM (Peak), 3000 RPM (Continuous) (up to Tmax)
<b>Protection Rating</b>	. . . . . IP 65 (IP 67 with Shaft Seal)
<b>Operating Temperature</b> <sup>1)</sup>	. . . . . -40° to +80°C (-40° to 176°F)
<b>Shock Resistance</b>	. . . . . Up to 250 g
<b>Vibration Resistance</b>	. . . . . Up to 100 g, 55-2000 Hz
<b>Humidity</b>	. . . . . 98% Relative, Non-Condensing
<b>Weight</b>	. . . . . Appr. 1.67 lbs with Bus terminal; Appr.1.10 lbs with Fixed Connection
<b>Materials</b>	. . . . . Shaft: Stainless Steel; Flange: Aluminum, Housing: Die-Cast Zinc, Cable: PVC
<b>Starting Torque w/o Shaft sealing (IP 65)</b>	. . . . . 1.42 oz.in.(<0.01Nm)
<b>Starting Torque w/Shaft sealing (IP 67)</b>	. . . . . 7.08 oz.in.(<0.05Nm)

<sup>1)</sup> Cable versions: -30° to +75°C (-22° to 167°F).

## General Electrical Characteristics:

<b>Supply Voltage</b>	. . . . . 10-30 VDC
<b>Current Consumption (w/o Output Load)</b>	. . . . . Max. 90 mA, 24 VDC
<b>Reverse Polarity</b>	
<b>Protection at Power Supply</b>	. . . . . Yes

Conforms to CE Requirements Acc. to EN 61000-6-1, EN61000-6-4 and EN 61000-6-3

## Interface Characteristics PROFIBUS-DP:

<b>Singleturn Resolution (Max., Scaleable)</b>	. . . . . 1-65536 (16 Bits), Default Scale Value is Set to 8192 (13 Bits)
<b>Code</b>	. . . . . Binary
<b>Interface</b>	. . . . . Specifications According to PROFIBUS-DP 2.0 Standard RS-485 Driver Galvanically isolated
<b>Protocol</b>	. . . . . PROFIBUS Encoder Profile V1.1 Class 1 and Class 2 with Manufacturer-specific Enhancements

## PROFIBUS Encoder-Profile V1.1:

The PROFIBUS-DP device profile describes the functionality of the communication and the user-specific component with in the PROFIBUS field bus system. For encoders, the encoder profile is definitive. Here the individual objects are defined independent of the manufacturer. Furthermore, the profiles offer space for additional manufacturer-specific functions; this means that PROFIBUS-compliant device systems can be used now with the guarantee that they are ready for the future too.

**Sendix® Absolute, Singleturn Shafted Type T8.5858 Specifications** **PROFIBUS® -DP**

**The Following Parameters Can Be Programmed:**

- Direction of rotation
- Scaling - Number of steps per revolution
- Preset value
- Diagnostics mode

**SET Control Button (Zero or Defined Value, Option):**

Protected against accidental activation, can only be pushed in with the tip of a ballpoint pen or similar.

**Diagnostic LED (yellow):**

**LED on at** . . . . . Optical sensor path faulty (code error, LED error), low voltage and overtemperature

**Protocol**

- Baud Rate** . . . . . 12 Mbits/s
- Node Address** . . . . . 1-127 (Set by Rotary Switches)
- Termination Switchable** . . . . . Set by DIP Switches, Software Configurable

**The Following Functionality Is Integrated:**

- Galvanic isolation of the bus stage with DC/DC converter
- Line driver acc. to RS 485 max. 12 MB
- Address programmable via DIP switches
- Diagnostics LED
- Full class 1 and class 2 functionality

5858 PROFIBUS® -DP

Standard Wiring / Pin Configuration

Terminal Assignment with Terminal Box (Connection 1)

Signal:	BUS IN				BUS OUT			
	B	A	0 V	+V	0 V	+V	B	A
Pin:	1	2	3	4	5	6	7	8

Terminal Assignment M12 - 3 Connector Version (Connection 2)

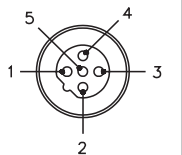
	Signal:	-	BUS-A	-	BUS-B	Shield	Male Pinout	Mating Cordsets <sup>2), 3), 4)</sup>
Bus In	Pin:	1	2	3	4	5		RKSW-455-*M

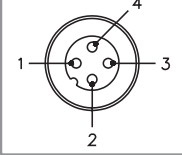
	Signal:	U <sub>B</sub>	-	0 V	-	Male Pinout	Mating Cordsets <sup>2), 4)</sup>
Power Supply	Pin:	1	2	3	4		RK 4.4T-*

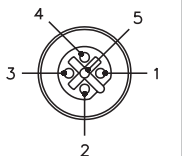
	Signal:	BUS-VDC <sup>1)</sup>	BUS-A	BUS_GND <sup>1)</sup>	BUS-B	Shield	Female Pinout	Mating Cordsets <sup>2), 3), 4)</sup>
Bus Out	Pin:	1	2	3	4	5		RSSW-455-*M

<sup>1)</sup> For powering an external PROFIBUS-DP terminating resistor.  
<sup>2)</sup> See cable section for additional options.  
<sup>3)</sup> "S" denotes shield tied to coupling nut.  
<sup>4)</sup> \* = length in meters, available in 0.1 meters increments  $\geq 0.2$  meters.

**Sendix® Absolute, Singleturn Shafted Type T8.5858 Dimensions** **PROFIBUS® -DP**

**T8.5858 Servo Flanges 2 & 4  
Cable Connection 1**

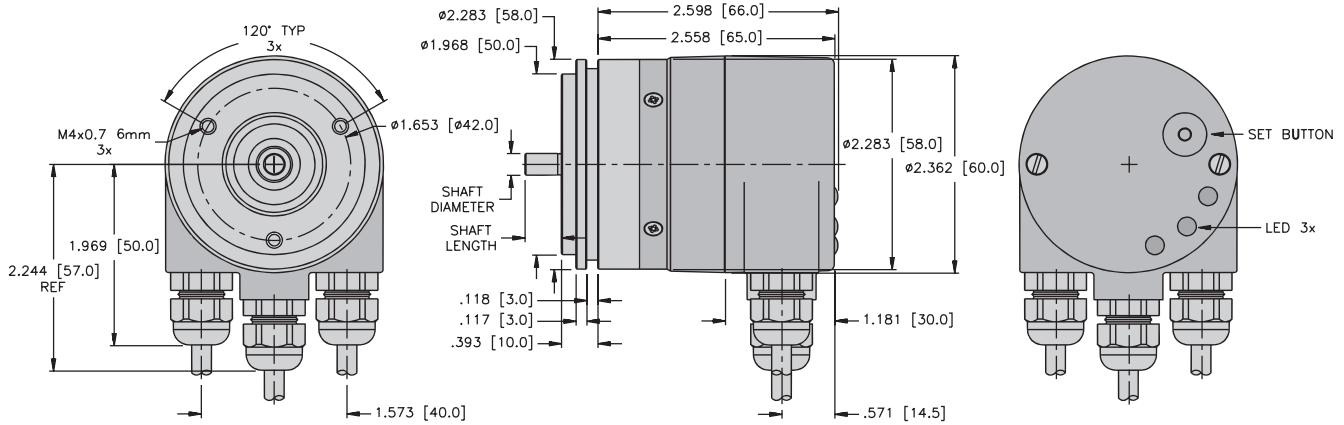

**T8.5858 Square Flanges 5 & 7  
Cable Connection 1**

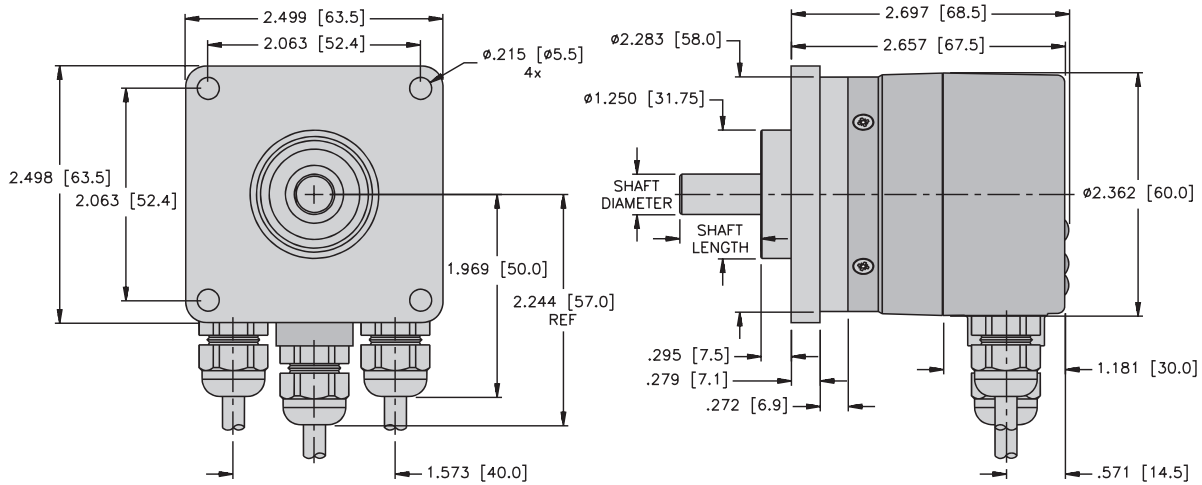

**T8.5858 Clamping Flanges 1 & 3  
M12 Connection 2**

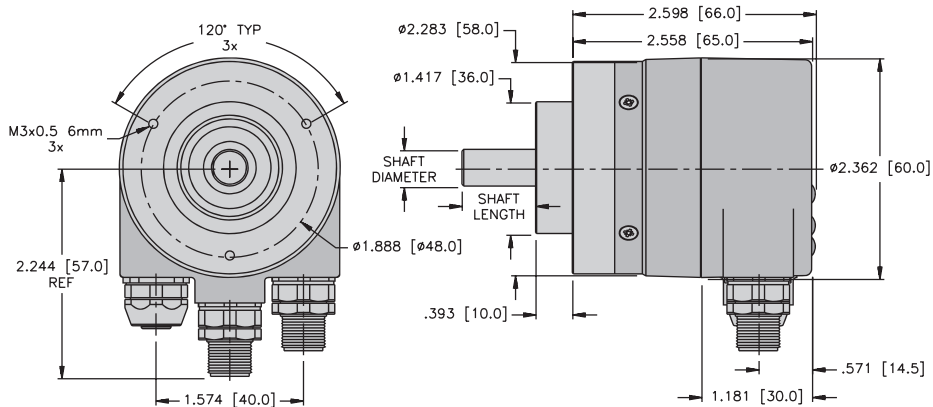

5858 PROFIBUS® -DP

# Kübler by TURCK Absolute Encoders

**Sendix** Absolute, Singleturn Hollow Shaft Type T8.5873 **SSI, BiSS**

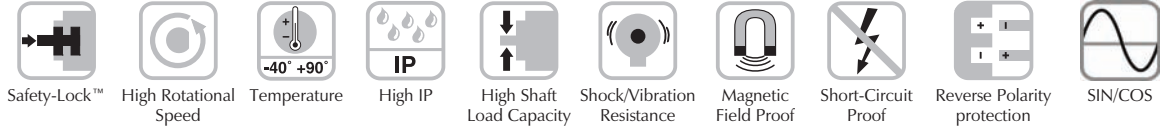

**T8. 5873. X X X X. XXXX.**

- Flange**
- 1 = Flange with torque stop IP 65
  - 2 = Flange with torque stop IP 67
  - 3 = Flange with stator coupling pitch circle Ø 65, IP 65
  - 4 = Flange with stator coupling pitch circle Ø 65, IP 67
  - 5 = Flange with stator coupling pitch circle Ø 63, IP 65
  - 6 = Flange with stator coupling pitch circle Ø 63, IP 67
- Hollow Shaft**
- 3 = Ø10 mm
  - 4 = Ø12 mm
  - 5 = Ø14 mm
  - 6 = Ø15 mm (blind hub shaft)
  - 8 = Ø9.52 mm [3/8"]
  - 9 = Ø12.7 mm [1/2"]
- Input / Output Circuit**
- 1 = 5 VDC / SSI or BiSS interface
  - 2 = 10-30 VDC / SSI or BiSS interface
  - 3 = 5 VDC / SSI or BiSS interface, and 2048 ppr SinCos
  - 4 = 10-30 VDC / SSI or BiSS interface, and 2048 ppr SinCos(M23)
  - 5 = 5 VDC / SSI or BiSS interface, with supply voltage monitoring output
  - 6 = 5 VDC / SSI or BiSS interface, and 2048 ppr SinCos, with supply voltage monitoring output
  - 7 = 5 VDC / SSI or BiSS and 2048 ppr-incremental track RS422 (TTL-comp.)
  - 8 = 10-30 VDC / SSI or BiSS and 2048 ppr-incremental track RS422 (TTL-comp.)
  - 9 = 5 VDC / SSI or BiSS and 2048 incremental track RS422 (TTL-comp.), with supply voltage monitoring output

- Options**<sup>1)</sup>
- 1 = No option
  - 2 = Status LED
  - 3 = Set button and status LED<sup>4)</sup>
- Input / Output**<sup>3)</sup>
- 2 = SET, DIR Inputs and additional status output
- Resolution**<sup>2)</sup>
- A = 10 bit
  - 1 = 11 bit
  - 2 = 12 bit
  - 3 = 13 bit
  - 4 = 14 bit
  - 7 = 17 bit
- Code**
- B = SSI, binary
  - C = BiSS, binary
  - G = SSI, Gray
- Connection Type**
- 2 = Radial cable (PVC, 1 meter)
  - 4 = Radial 12-pin, M23 (*multifast*®)
  - 6 = Radial M12, 8-pin (*eurofast*®)

<sup>1)</sup> Status LED internally monitors encoder parameters such as; sensor condition, temperature, under and over voltage.  
<sup>2)</sup> Preset value, factory-programmable.  
<sup>3)</sup> Set and Direction are physical inputs for setting: 0 position (or any factory predefined value); controls rotation of shaft (CW/CCW) for increasing counts. Status output is discrete output linked to the LED status indicator.  
<sup>4)</sup> The Set button and Status LED are located on the rear of the encoder cover. Same functionality as SET control input, protected against accidental activation, can only be pushed in with the tip of a ballpoint pen or similar.

## Features / Benefits

- Update rate of 100 KHz for real time transmission
- Sinusoidal or square wave incremental signals (optional)
- SSI clock rate to 2Mhz
- BiSS clock rate to 10Mhz
- Captive bearings
- Wide temperature range



**Sendix® Absolute, Singleturn Hollow Shaft Type T8.5873 Specifications** **SSI, BiSS**

**Mechanical:**

- Max. Speed w/o Shaft Sealing (IP 65) . . . . 9000 RPM (Peak), 6000 RPM (Continuous) (up to 70°C)
- Max. Speed w/o Shaft Sealing (IP 65) . . . . 6000 RPM (Peak), 3000 RPM (Continuous) (up to Tmax)
- Max. Speed w/Shaft Sealing (IP 67) . . . . 8000 RPM (Peak), 4000 RPM (Continuous) (up to 70°C)
- Max. Speed w/Shaft Sealing (IP 67) . . . . 4000 RPM (Peak), 2000 RPM (Continuous) (up to Tmax)
- Protection Rating . . . . . IP 65 (IP 67 with Shaft Seal)
- Operating Temperature<sup>1</sup> . . . . . -40° to +90°C (-40° to +194°F)
- Shock Resistance . . . . . Up to 250 g
- Vibration Resistance . . . . . Up to 100 g, 55-2000 Hz
- Humidity . . . . . 98% Relative, Non-Condensing
- Weight . . . . . Appr. 0.77lbs
- Materials . . . . . Shaft: Stainless Steel; Flange: Aluminum, Housing: Die-Cast Zinc, Cable: PVC
- Starting Torque w/o Shaft sealing (IP 65) . . . . 4.24 oz.in.(<0.03Nm)
- Starting Torque w/Shaft sealing (IP 67) . . . . 7.08 oz.in.(<0.05 Nm)

**General Electrical Characteristics:**

Interface . . . . .	<b>BiSS, SSI / 5 VDC</b> . . . . .	<b>BiSS, SSI / 10-30 VDC</b>
Output Driver . . . . .	RS 485 (Transceiver Type) . . . . .	RS 485 (Transceiver Type)
Current Consumption (Typ./Max.) . . . . .	70 mA @ SVDC . . . . .	20 mA @ 24 VDC
Load / Channel (Max.) . . . . .	±20 mA . . . . .	±20 mA
Signal Level High (Typ.) . . . . .	3.8 V . . . . .	3.8 V
Signal Level Low (Typ.) . . . . .	1.3 V . . . . .	1.3 V
Short-Circuit Proof <sup>2)</sup> . . . . .	Yes <sup>2)</sup> . . . . .	Yes <sup>2)</sup>
Reverse Polarity Protection . . . . .	No. . . . .	Yes

**Interface Characteristics SSI:**

- Singleturn Resolution . . . . . 10-14 Bits and 17 Bits<sup>3)</sup>
- Code . . . . . Binary or Gray
- SSI Clock Rate . . . . . ≤14 bits: 50 kHz - 2 MHz
- Monoflop Time . . . . . ≥15 μs<sup>3)</sup>
- Time Jitter (Data Request to Position Latch) <1μs up to 14 bits  
≤4 μs at 15-17 bits
- Status and Parity Bit . . . . . Optional on Request

**Note:** If clock starts cycling within monoflop time a second data transfer starts with the same data, double clocking is useful for data verification. If clock starts cycling after monoflop time the data transfer starts with updated values. Max. update rate is depending on clock speed, data length and monoflop-time.

<sup>1)</sup> Cable Versions: -30° to +75°C (-22° to 167°F).  
<sup>2)</sup> Short circuit to 0 V or to output, one channel at a time, supply voltage correctly applied.  
<sup>3)</sup> Other options upon request.



5873 SSI, BiSS

### Interface Characteristics BiSS:

<b>Singleturn Resolution</b> . . . . .	10-14 Bits and 17 Bits, Customer Programmable <sup>1)</sup>
<b>Code</b> . . . . .	Binary
<b>Interfaces</b> . . . . .	RS 485
<b>Clock Rate</b> . . . . .	Up to 10 MHz
<b>Max. Update Rate</b> . . . . .	<10 µs, Depending on Clock Speed and Data Length
<b>Time Jitter (data request to position latch)</b> . . . . .	≤1 µs

**Note:** Bidirectional, programmable parameters are: resolution, code, direction, alarms and warnings.  
Multicycle data output, e.g. for temperature.  
CRC data verification.

### SET (Zero or Defined Value) and DIRection (cw/ccw) Control Inputs:

<b>Input Characteristic</b> . . . . .	High Active
<b>Receiver Type</b> . . . . .	Comparator
<b>Signal Level High</b> . . . . .	Min. 60% of V+ (Supply Voltage), Max: V+
<b>Signal Level Low</b> . . . . .	Max. 25% of V+
<b>Input Current</b> . . . . .	≤0.5 mA
<b>Min. Pulse Duration (SET)</b> . . . . .	10 ms
<b>Timeout After SET Input</b> . . . . .	14 ms
<b>Reaction Time (DIR Input)</b> . . . . .	1 ms

### Status Output:

<b>Output Driver</b> . . . . .	Open Collector, Internal Pull Up Resistor 22 kΩ
<b>Permissible Load</b> . . . . .	≤20 mA
<b>Signal Level High</b> . . . . .	V+
<b>Signal Level Low</b> . . . . .	<1 V
<b>Active At</b> . . . . .	Low

Optical sensor path faulty (code error, LED error), low voltage and overtemperature.

<sup>1)</sup> Other options upon request.

**Sendix® Absolute, Singleturn Hollow Shaft Type T8.5873 Specifications** **SSI, BiSS**

**Status LED (Red, Option):**

LED on at . . . . . Optical sensor path faulty (code error, LED error), low voltage and overtemperature

**SET Control Button (Zero or Defined Value, Option):**

Same functionality as SET control input, protected against accidental activation, can only be pushed in with the tip of a ballpoint pen or similar.

**Output Sine, Cosine, 2048 ppr (Option):**

	Sin/Cos	RS422 (TTL Compatible)
-3dB Frequency . . . . .	400 kHz . . . . .	400 kHz
Signal Level . . . . .	1 Vpp (± 20%) . . . . .	High: min 2.5 V Low: max. 0.5 V
Short Circuit Proof <sup>1)</sup> . . . . .	Yes . . . . .	Yes

<sup>1)</sup> Short-circuit to 0 V or to output, one channel at a time, supply voltage correctly applied.



5873 SSI, BiSS

# Kübler by TURCK

## Absolute Encoders

### Sendix® Absolute, Singleturn Hollow Shaft Type T8.5873 Specifications

SSI, BiSS

#### Pinouts Notes 1), 2), 3)

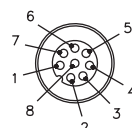
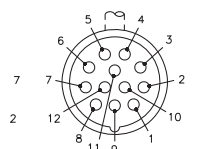
Male Encoder View	Mating Cordsets
<p><b>M12 Pinout</b></p> 	E-RKS 8T-264-*
<p><b>M23 Pinout (12-Pin)</b></p>  <p>CCW</p>	E-CKM 12-1687-*/A

- 1) See cable section for additional options.
- 2) "S" denotes shield tied to coupling nut.
- 3) \* = length in meters, available in 0.1 meter increments  $\geq 0.2$  meters.

#### Standard Wiring / Pin Configuration

##### Output Circuit 1 or 2 and (2 Control Inputs, 1 Status Output)

(Connection 1,2,3 or 4)

Output	Common	+V	+Clock	-Clock	+Data	-Data	ST	DIR	Status	NC	NC	NC	PE
M23 Pin	1	2	3	4	5	6	7	8	9	10	11	12	PH
Color	WH	BN	GN	YE	GY	PK	BU	RD	BK	-	-	-	Shield

##### Output Circuit 5 and (2 Control Inputs, 1 Status Output, Voltage Monitor Outputs)

(Connection 1,2,3 or 4)

Output	Common	+V	+Clock	-Clock	+Data	-Data	ST	DIR	Status	NC	0 V Sens	+Ub Sens	PE
M23 Pin	1	2	3	4	5	6	7	8	9	10	11	12	PH
Color	WH	BN	GN	YE	GY	PK	BU	RD	BK	-	GY/PK	RD/BU	Shield

##### Output Circuit 3, 4, 7 or 8, and (2 Control inputs, or Incremental Track, Sine/Cosine)

(Connection 1,2,3 or 4)

Output	Common	+V	+Clock	-Clock	+Data	-Data	ST	DIR	Sin A	Sin inv A-	Cos B	Cos inv B-	PE
M23 Pin	1	2	3	4	5	6	7	8	9	10	11	12	PH
Color	WH	BN	GN	YE	GY	PK	BU	RD	BK	VT	GY/PK	RD/BU	Shield

##### Output Circuit 6 or 9 and (Sine/Cosine, or Incremental Monitor, Voltage Outputs)

(Connection 1,2,3 or 4)

Output	Common	+V	+Clock	-Clock	+Data	-Data	Sin A	Sin inv A-	Cos B	Cos inv B-	0 V Sens	V+ Sens	PE
M23 Pin	1	2	3	4	5	6	7	8	9	10	11	12	PH
Color	WH	BN	GN	YE	GY	PK	BU	RD	BK	VT	GY/PK	RD/BU	Shield

##### Output Circuit 1 or 2 and (2 Control Inputs)

(Connection 5 or 6)

Output	Common	+V	+Clock	-Clock	+Data	-Data	SET	DIR	Shield/PE
M12 Pin	1	2	3	4	5	6	7	8	PH

**Sendix® Absolute, Singleturn Hollow Shaft Type T8.5873 Dimensions** **SSI, BiSS**

**T8.5873 Flanges 3 & 4  
Cable Connection 2**

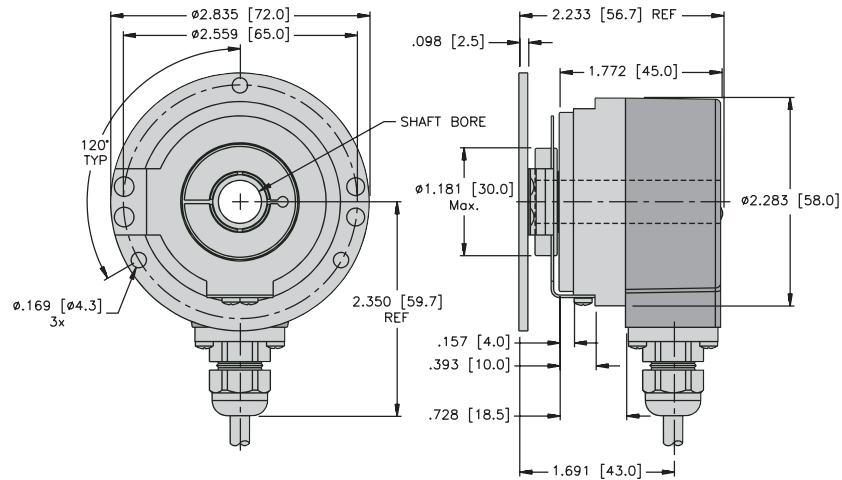

**T8.5873 Flanges 5 & 6  
M23 Connection 4**

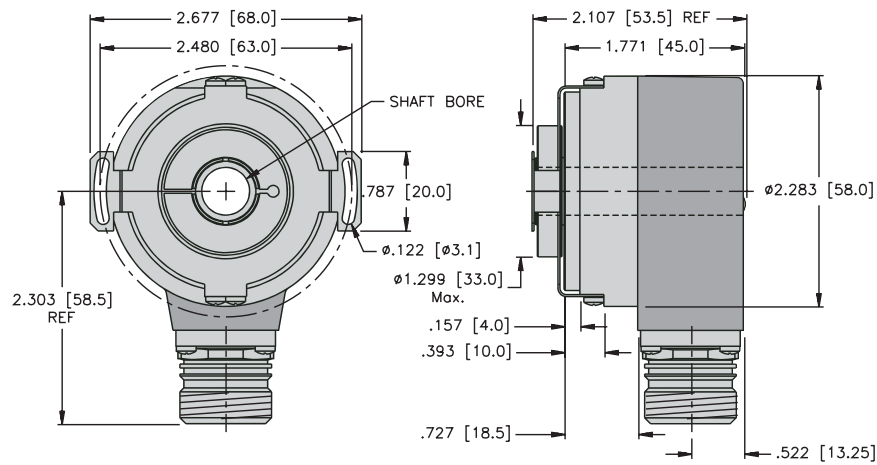

**T8.5873 Flanges 1 & 2  
M12 Connection 6**

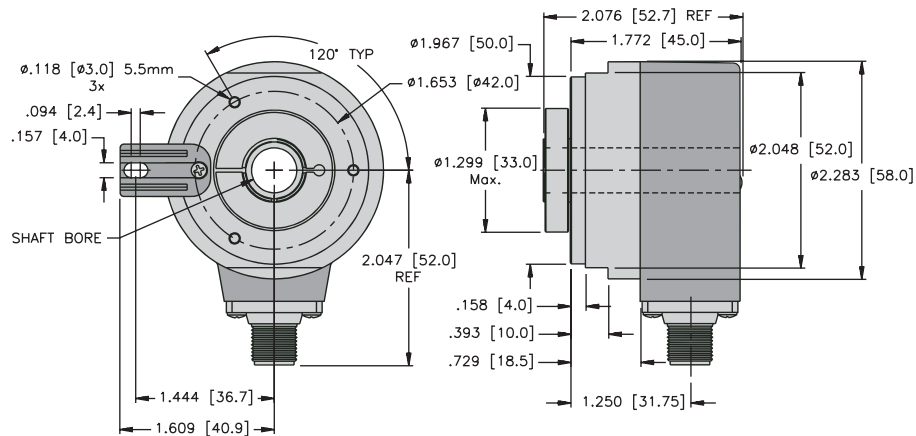

5873 SSI, BiSS

# Kübler by TURCK Absolute Encoders

**Sendix** Absolute, Singleturn Hub Shaft Type T8.5878

**CANopen**

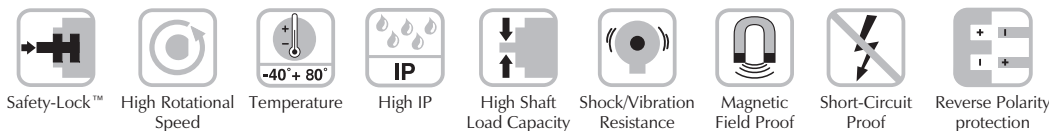

**T8. 5878. X X X X. XX1X.**

### Flange

- 1 = Flange with torque stop IP 65
- 2 = Flange with torque stop IP 67
- 3 = Flange with stator coupling pitch circle Ø 65, IP 65
- 4 = Flange with stator coupling pitch circle Ø 65, IP 67
- 5 = Flange with stator coupling pitch circle Ø 63, IP 65
- 7 = Flange with stator coupling pitch circle Ø 63, IP 67

### Blind Hub Shaft

- 3 = Ø10 mm
- 4 = Ø12 mm
- 5 = Ø14 mm
- 6 = Ø15 mm
- 8 = Ø9.52 mm [3/8"]
- 9 = Ø12.7 mm [1/2"]

### Input / Output Circuit

- 2 = 10-30 VDC CANopen DS 301 V4.02

### Options

- 2 = No option
- 3 = Set button

### Fieldbus Profile <sup>1)</sup>

- 21 = CANopen Encoder-Profile DS 406 V3.1
- 22 = CANlift DS 417 V1.01

### Connection Type

- 1 = Removable bus terminal cover, with radial screwed cable passage
- 2 = Removable bus terminal cover with 2 - M12 **euromast**® connectors
- A = Fixed connection without bus terminal cover with radial cable (PVC 2 meter) <sup>2)</sup>
- E = Fixed connection without bus terminal cover with 1 - M12 **euromast** radial connector <sup>2)</sup>
- F = Fixed connection without bus terminal cover with 2 - M12 **euromast** radial connectors <sup>2)</sup>
- I = Fixed connection without bus terminal cover with 1 - M23 **multifast**® radial connector <sup>2)</sup>
- J = Fixed connection without bus terminal cover with 2 - M23 **multifast** radial connectors <sup>2)</sup>

<sup>1)</sup> CANopen parameters can also be factory preset. Please consult factory.

<sup>2)</sup> Baud rate, address, and termination can not be set through dip-switches and must be configured via the bus program.

## Features / Benefits

- Captive bearings
- Wide temperature range
- Many connector styles; M12, fixed cover, removable cover, etc
- Heavy duty diecast cover
- Compact size
- High speed integrated OptoASIC
- High IP rating

**Sendix® Absolute, Singleturn Hub Shaft Type T8.5878 Specifications** **CANopen**

**Mechanical:**

- Max. Speed w/o Shaft sealing (IP 65)** . . . . 9000 RPM (Peak), 7000 RPM (Continuous) (up to 70°C)
- Max. Speed w/o Shaft sealing (IP 65)** . . . . 7000 RPM (Peak), 4000 RPM (Continuous) (up to Tmax)
- Max. Speed w/Shaft sealing (IP 67)** . . . . 8000 RPM (Peak), 6000 RPM (Continuous) (up to 70°C)
- Max. Speed w/Shaft sealing (IP 67)** . . . . 6000 RPM (Peak), 3000 RPM (Continuous) (up to Tmax)
- Protection Rating** . . . . . IP 65 (IP 67 with Shaft Seal)
- Operating Temperature<sup>1)</sup>** . . . . . -40° to +80°C (-40° to +176°F)
- Shock Resistance** . . . . . Up to 250 g
- Vibration Resistance** . . . . . Up to 100 g, 55-2000 Hz
- Humidity** . . . . . 98% Relative, Non-Condensing
- Weight** . . . . . Appr. 1.67 lbs with Bus Terminal Cover; Appr. 1.10 lbs with Fixed Connection
- Materials** . . . . . Shaft: Stainless Steel; Flange: Aluminum, Housing: Die-Cast Zinc, Cable: PVC
- Starting Torque w/o Shaft sealing (IP 65)** . . 1.42 oz.in.(<0.01Nm)
- Starting Torque w/Shaft sealing (IP 67)** . . . 7.08 oz.in.(<0.05Nm)

<sup>1)</sup> Cable versions: -30° to +75°C (-22° to 167°F).

**General Electrical Characteristics:**

- Supply Voltage** . . . . . 10-30 VDC
  - Current Consumption (w/o Output Load)** . Max. 60 mA, 24 VDC
  - Reverse Polarity**
  - Protection at Power Supply (Ub)** . . . . . Yes
- Conforms to CE Requirements Acc. to EN 61000-6-1, EN61000-6-4 and EN 61000-6-3

**Interface Characteristics CANopen:**

- Singleturn Resolution (Max., Scaleable)** . . 1-65536 (16 Bits), Default Scale Value is Set to 8192 (13 Bits)
- Code** . . . . . Binary
- Interface** . . . . . CAN High-Speed According ISO 11898, Basic - and Full-CAN, CAN Specification 2.0 B

**General Information About CANopen:**

The CANopen encoders of the 5878 series support the latest CANopen communication profile according to DS 301 V4.02. In addition, device-specific profiles like the encoder profile DS 406 V3.1 are available. The following operating modes may be selected: Polled Mode, Cyclic Mode, Sync Mode and a High Resolution Sync Protocol. Additionally, scale factors, preset values, limit switch values and many other parameters can be programmed via the CANBus. When switching the device on, all parameters, which have been saved on an EEPROM to protect them against power failure, are reloaded. The following output values may be combined by PDO mapping: position, speed, acceleration, and status.

5878 CANopen

### CANopen Communication Profile DS 301 V4.02:

Among others, the following functionality is integrated:

Class C2 Functionality

- NMT slave
- Heartbeat protocol
- High resolution sync protocol identity object
- Error behavior object
- Variable PDO mapping self-start programmable (power on to operational), 3 sending PDO's
- 1 Receiving PDO for synchronous preset operation with minimal jitter
- Node address, baud rate and CANbus
- Programmable termination

### SET Control Button (Zero or Defined Value, Option):

Protected against accidental activation, can only be pushed in with the tip of a ballpoint pen or similar.

### Diagnostic LED (yellow):

**LED on at** . . . . . Optical sensor path faulty (code error, LED error), low voltage and overtemperature

**Protocol** . . . . . CANopen Profile DS 406 V3.1 with Manufacturer-Specific Add-Ons

**Baud Rate** . . . . . 10-1000 kbits/s (Set by DIP Switches/Software Configurable)

**Node Address** . . . . . 1-127 (Set by Rotary Switches/Software Configurable)

**Termination Switchable** . . . . . Set by DIP Switches, Software Configurable

Price conscience encoders are available with optional connectors or cable connections in place of the costlier removable terminal box versions. Additionally, these encoders do not have user accessible DIP switches and require the user to program the address and baud rate through the software.

The models with the terminal cover include an integrated T-shaped coupler with the bus and power connections utilizing simple M12 connectors. The device address is set with two rotary switches while a bank of DIP switches set the baud rate and also allows the connection of a termination resistor.

Finally, all versions include three LED's located on the rear of the housing to indicate the status of the CAN bus as well as the status of the internal diagnostics.

### CANopen Encoder Profile V3.1:

The following parameters can be programmed:

- Event mode
- Units for speed selectable (steps/sec or RPM)
- Factor for speed calculation (e.g. measuring wheel periphery) Integration time for speed value of 1-32
- 2 work areas with 2 upper and lower limits and the corresponding output states
- Variable PDO mapping for position, speed, acceleration, work area, status
- Extended failure management for position sensing with integrated temperature control
- User interface with visual display of bus and failure status - 3 LED's
- Optional - 32 CAM's programmable
- Customer-specific memory - 16 Bytes

**Note:** All profiles stated here: Key-features.

The object 6003h "Preset" is assigned to an integrated key, accessible from the outside "Watchdog-controlled" device.



**Sendix® Absolute, Singleturn Hub Shaft Type T8.5878 Specifications** **CANopen**

**Pinouts** Notes 1), 2), 3)

A Male Encoder View	B Female Encoder View	C Male Encoder View
CCW		
<b>Bus In and Out M23</b>	<b>Bus Out M12 Pinout</b>	<b>Bus In M12 Pinout</b>
<b>Mating Cordset</b>	<b>Mating Cordset</b>	<b>Mating Cordset</b>
Consult Factory	RSC 572-*M	RKC 572-*M

- 1) See cable section for additional options.
- 2) "S" denotes shield tied to coupling nut.
- 3) \* = length in meters, available in 0.1 meter increments ≥0.2 meters.

**Standard Wiring / Pin Configuration**

Bus Terminal Cover with Terminal Box

(Connection 1)

Direction	OUT					IN				
Signal:	CAN Ground	CAN_Low (-)	CAN_High (+)	0 VOLT Power Supply	+VOLT Power Supply	0 VOLT Power Supply	+VOLT Power Supply	CAN_Low (-)	CAN_High (+)	CAN Ground
Abbreviation:	CG	CL	CH	0 V	+V	0 V	+V	CL	CH	CG

Cable Connection

(Connection A)

Direction	IN				
Signal:	0 VOLT Power Supply	+VOLT Power Supply	CAN_Low (-)	CAN_High (+)	CAN Ground
Abbreviation:	0 V	+V	CL	CH	CG
Cable Color	BK	RD	BL	WH	GY

M23 Connector or M12 Connector

(Connection I) (Connection E)

Direction	IN					Pinout
Signal:	0 VOLT Power Supply	+VOLT Power Supply	CAN_Low (-)	CAN_High (+)	CAN Ground	
Abbreviation:	0 V	+V	CL	CH	CG	
M23 PIN Assignment:	10	12	2	7	3	A
M12 PIN Assignment:	3	2	5	4	1	C

Bus Terminal Cover with 2 - M12, 2 - M12, 2 - M23

(Connection 2) (Connection F) (Connection J)

Direction	OUT					Pinout	IN					Pinout
Signal:	CAN Ground	CAN_Low (-)	CAN_High (+)	0 VOLT Power Supply	+VOLT Power Supply		0 VOLT Power Supply	+VOLT Power Supply	CAN_Low (-)	CAN_High (+)	CAN Ground	
Abbreviation:	CG	CL	CH	0 V	+V		0 V	+V	CL	CH	CG	
M23 PIN Assignment:	3	2	7	10	12	A	10	12	2	7	3	A
M12 PIN Assignment:	1	5	4	3	2	B	3	2	5	4	1	C

5878 CANopen

T8.5878 Flanges 3 & 4  
Cable Connection 1

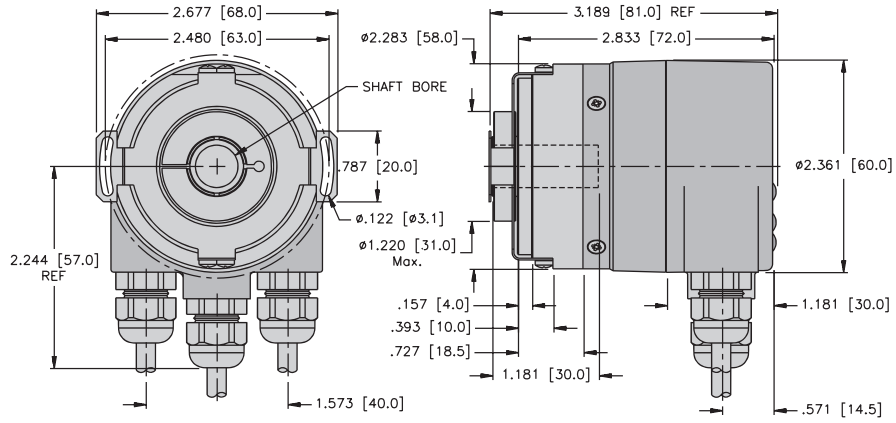

T8.5878 Flanges 3 & 4  
M12 Connection 2

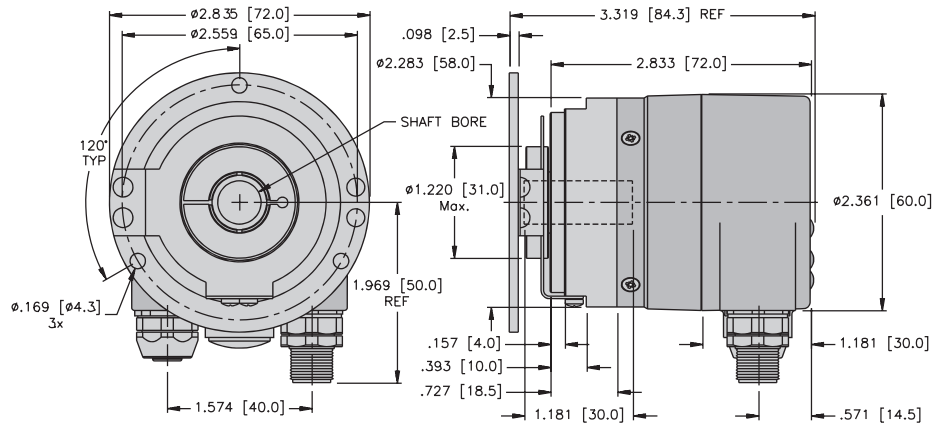

T8.5878 Flanges 1 & 2  
M12 Connection 2

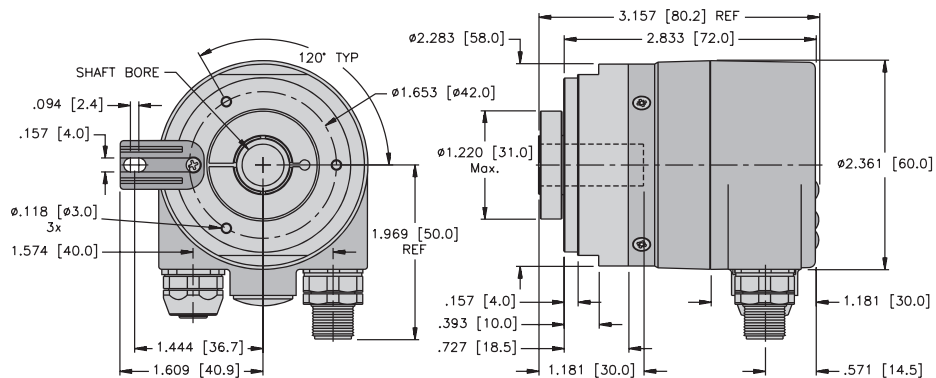

**Sendix® Absolute, Singleturn Hub Shaft Type T8.5878 Dimensions** **CANopen**

**T8.5878 Flanges 5 & 6  
Cable Connection A**

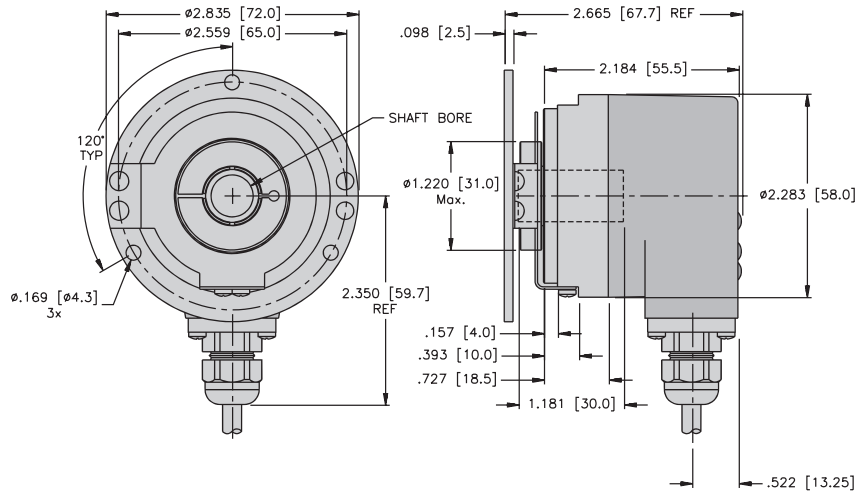

**T8.5878  
M12 Connection E**

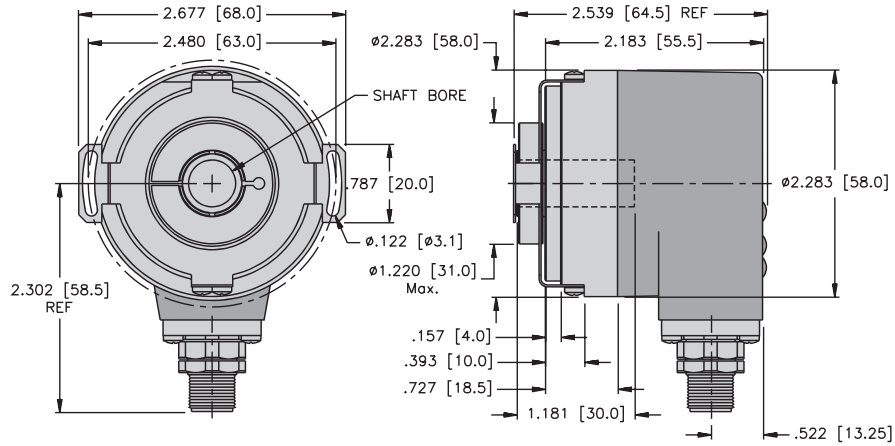

**T8.5878 Flanges 1 & 2  
M12 Connection F**

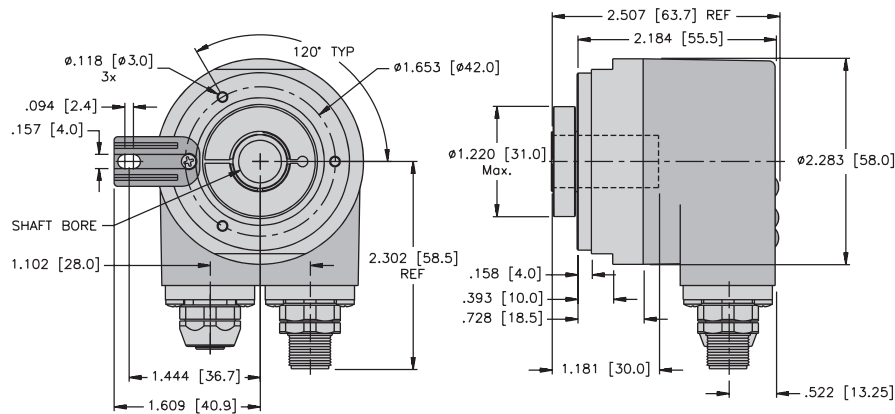

5878 CANopen

**T8.5878**  
**M23 Connection I**

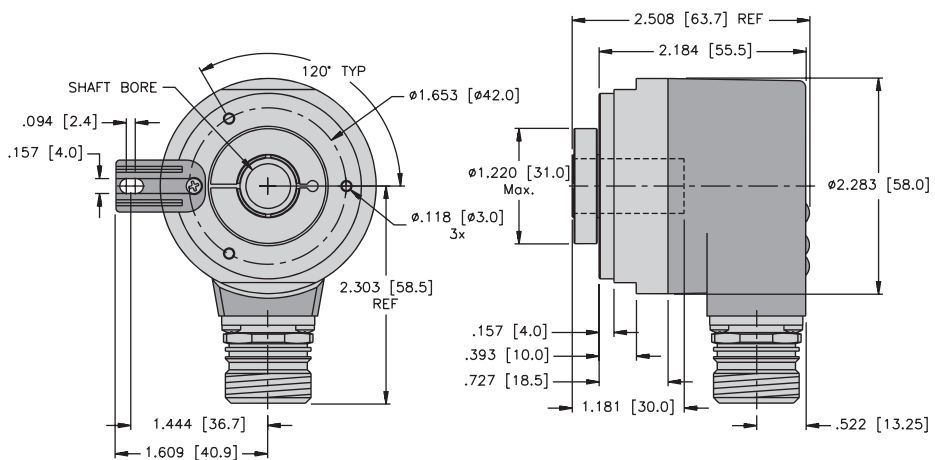

**T8.5878**  
**M23 Connection J**

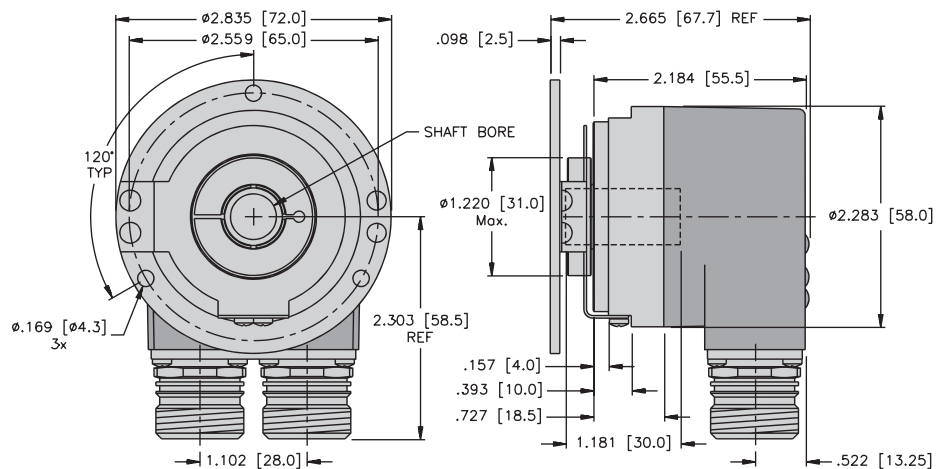

**Sendix® Absolute, Singleturn Hub Shaft Type T8.5878 PROFIBUS®-DP**

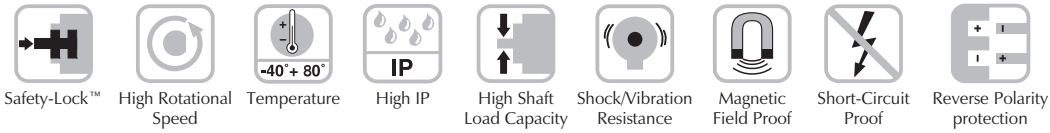

**T8. 5878. X X X X. XX1X.**

- Flange**
- 1 = Flange with torque stop IP 65
  - 2 = Flange with torque stop IP 67
  - 3 = Flange with stator coupling pitch circle Ø 65, IP 65
  - 4 = Flange with stator coupling pitch circle Ø 65, IP 67
  - 5 = Flange with stator coupling pitch circle Ø 63, IP 65
  - 6 = Flange with stator coupling pitch circle Ø 63, IP 67
- Blind Hub Shaft**
- 3 = Ø10 mm
  - 4 = Ø12 mm
  - 5 = Ø14 mm
  - 6 = Ø15 mm
  - 8 = Ø9.52 mm [3/8"]
  - 9 = Ø12.7 mm [1/2"]
- Input / Output Circuit**
- 3 = 10-30 VDC PROFIBUS-DP V0 Encoder Profile V 1

- Options**
- 2 = No option
  - 3 = Set button
- Fieldbus Profile**
- 31 = PROFIBUS-DP-V0 Encoder Profile Class 2
- Connection Type**
- 1 = Removable bus terminal cover, with radial screwed cable passage
  - 2 = Removable bus terminal cover with 3 - M12 *euromast*® connectors

**5878 PROFIBUS®-DP**

**Features / Benefits**

- Captive bearings
- Wide temperature range
- Removable terminal box with M12 connector and cable versions
- Heavy duty diecast cover
- Compact size
- High speed integrated OptoASIC
- High IP rating

# Kübler by TURCK Absolute Encoders

**Sendix** Absolute, Singleturn Hub Shaft Type T8.5878 Specifications

**PROFIBUS®-DP**

## Mechanical:

<b>Max. Speed w/o Shaft sealing (IP 65)</b>	. . . . . 9000 RPM (Peak), 7000 RPM (Continuous) (up to 70°C)
<b>Max. Speed w/o Shaft sealing (IP 65)</b>	. . . . . 7000 RPM (Peak), 4000 RPM (Continuous) (up to Tmax)
<b>Max. Speed w/Shaft sealing (IP 67)</b>	. . . . . 8000 RPM (Peak), 6000 RPM (Continuous) (up to 70°C)
<b>Max. Speed w/Shaft sealing (IP 67)</b>	. . . . . 6000 RPM (Peak), 3000 RPM (Continuous) (up to Tmax)
<b>Protection Rating</b>	. . . . . IP 65 (IP 67 with Shaft Seal)
<b>Operating Temperature</b>	. . . . . -40° to +80°C (-40° to +176°F)
<b>Shock Resistance</b>	. . . . . Up to 250 g
<b>Vibration Resistance</b>	. . . . . Up to 100 g, 55-2000 Hz
<b>Humidity</b>	. . . . . 98% Relative, Non-Condensing
<b>Weight</b>	. . . . . Appr. 1.67 lbs with Bus Terminal Cover; Appr. 1.10 lbs with Fixed Connection
<b>Materials</b>	. . . . . Shaft: Stainless Steel; Flange: Aluminum, Housing: Die-Cast Zinc, Cable: PVC
<b>Starting Torque w/o Shaft sealing (IP 65)</b>	. . . . . 1.42 oz.in.( $<0.01\text{Nm}$ )
<b>Starting Torque w/Shaft sealing (IP 67)</b>	. . . . . 7.08 oz.in.( $<0.05\text{Nm}$ )

## General Electrical Characteristics:

<b>Supply Voltage</b>	. . . . . 10-30 VDC
<b>Current Consumption (w/o Output Load)</b>	. . . . . Max. 90 mA, 24 VDC
<b>Reverse Polarity</b>	
<b>Protection at Power Supply (Ub)</b>	. . . . . Yes

Conforms to CE Requirements Acc. to EN 61000-6-1, EN61000-6-4 and EN 61000-6-3

## Interface Characteristics PROFIBUS-DP:

<b>Singleturn Resolution (Max., Scaleable)</b>	. . . . . 1-65536 (16 Bits), Default Scale Value is Set to 8192 (13 Bits)
<b>Code</b>	. . . . . Binary
<b>Interface</b>	. . . . . Specifications According to PROFIBUS-DP 2.0 Standard RS-485 Driver Galvanically Isolated
<b>Protocol</b>	. . . . . PROFIBUS Encoder Profile V1.1 Class 1 and Class 2 with Manufacturer-specific Enhancements

## PROFIBUS Encoder-Profile V1.1:

The PROFIBUS-DP device profile describes the functionality of the communication and the user-specific component within the PROFIBUS field bus system. For encoders, the encoder profile is definitive. Here the individual objects are defined independent of the manufacturer. Furthermore, the profiles offer space for additional manufacturer-specific functions; this means that PROFIBUS-compliant device systems can be used now with the guarantee that they are ready for the future too.

**Sendix® Absolute, Singleturn Hub Shaft Type T8.5878 Specifications** **PROFIBUS®-DP**

**The Following Parameters Can Be Programmed:**

- Direction of rotation
- Scaling - Number of steps per revolution
- Preset value
- Diagnostics mode

**SET Control Button (Zero or Defined Value, Option):**

Protected against accidental activation, can only be pushed in with the tip of a ballpoint pen or similar.

**Diagnostic LED (yellow):**

LED on at . . . . . Optical sensor path faulty (code error, LED error), low voltage and overtemperature

**Protocol**

- Baud Rate** . . . . . 12 Mbits/s
- Node Address** . . . . . 1-127 (Set by Rotary Switches)
- Termination Switchable** . . . . . Set by DIP Switches, Software Configurable

**The Following Functionality Is Integrated:**

- Galvanic isolation of the bus stage with DC/DC converter
- Line driver acc. to RS 485 max. 12 MB
- Address programmable via DIP switches
- Diagnostics LED
- Full class 1 and class 2 functionality

5878 PROFIBUS®-DP

Standard Wiring / Pin Configuration

Terminal Assignment with Terminal Box (Connection 1)

Signal:	BUS IN				BUS OUT			
	B	A	0 V	+V	0 V	+V	B	A
Pin:	1	2	3	4	5	6	7	8

Terminal Assignment M12 - 3 Connector Version (Connection 2)

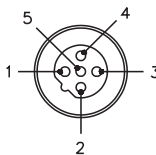
	Signal:	-	BUS-A	-	BUS-B	Shield	Male Pinout	Mating Cordsets <sup>2), 3), 4)</sup>
Bus In	Pin:	1	2	3	4	5		RKSW-455-*M

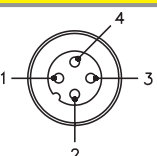
	Signal:	U <sub>B</sub>	-	0 V	-	Male Pinout	Mating Cordsets <sup>2), 4)</sup>
Power Supply	Pin:	1	2	3	4		RK 4.4T-*

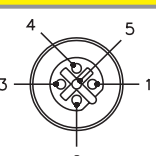
	Signal:	BUS-VDC <sup>1)</sup>	BUS-A	BUS_GND <sup>1)</sup>	BUS-B	Shield	Female Pinout	Mating Cordsets <sup>2), 3), 4)</sup>
Bus Out	Pin:	1	2	3	4	5		RSSW-455-*M

<sup>1)</sup> For powering an external PROFIBUS-DP terminating resistor.  
<sup>2)</sup> See cable section for additional options.  
<sup>3)</sup> "S" denotes shield tied to coupling nut.  
<sup>4)</sup> \* = length in meters, available in 0.1 meters increments ≥0.2 meters.



**Sendix® Absolute, Singleturn Hub Shaft Type T8.5878 Dimensions** **PROFIBUS®-DP**

**T8.5878 Flanges 3 & 4  
Cable Connection 1**

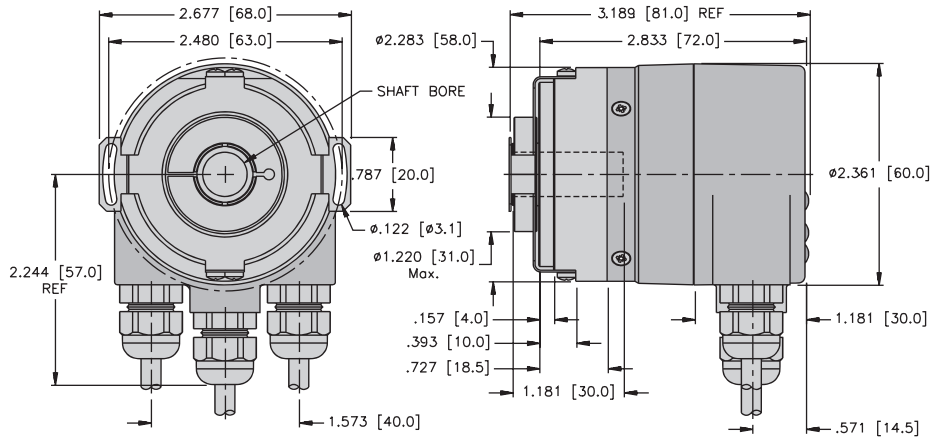

**T8.5878 Flanges 5 & 6  
Cable Connection 1**

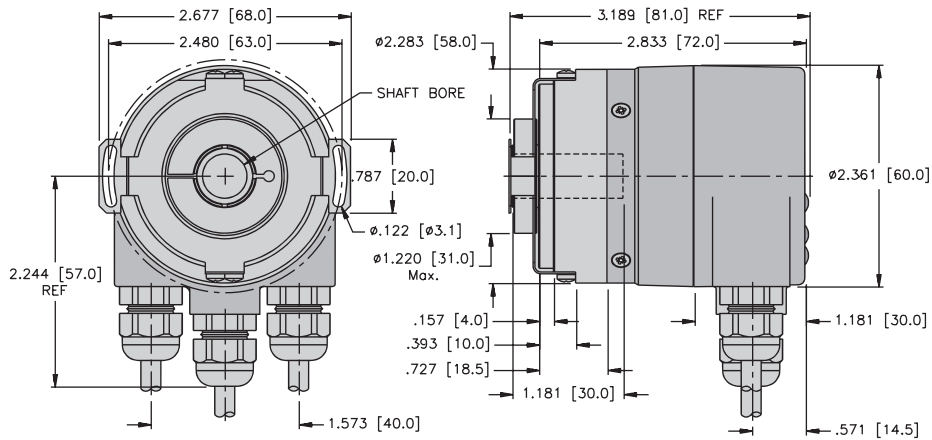

**T8.5878 Flanges 1 & 2  
M12 Connection 2**

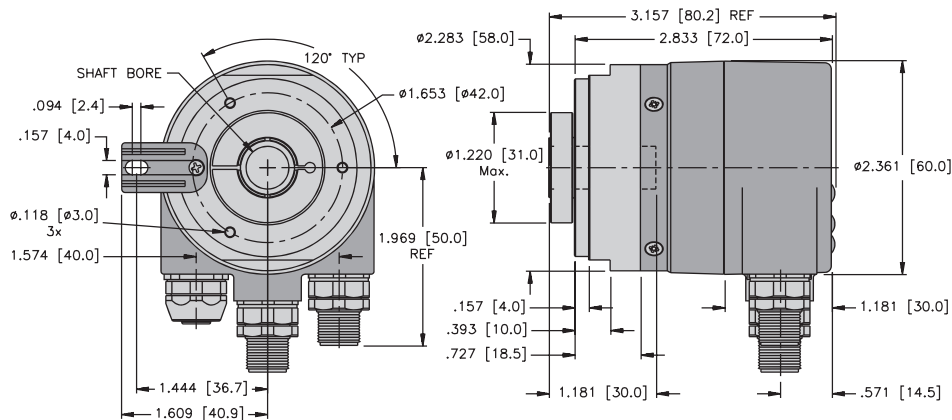

5878 PROFIBUS®-DP

# Kübler by TURCK Absolute Encoders

**Sendix** Absolute, Multiturn Shafted Type T8.5863

SSI, BiSS



Mechanical Drive



Safety-Lock™



High Rotational Speed



Temperature  
-40° +90°



High IP



High Shaft Load Capacity



Shock/Vibration Resistance



Magnetic Field Proof



Short-Circuit Proof



Reverse Polarity protection



SIN/COS

**T8. 5863. X X X X. XXXX.**

## Flange

- 1 = Clamping Flange Ø58 mm, IP 65
- 2 = Servo Flange Ø58 mm, IP 65
- 3 = Clamping Flange Ø58 mm, IP 67
- 4 = Servo Flange Ø58 mm, IP 67
- 5 = Square Flange 2.5"/63.5 mm, IP 65
- 6 = Servo Flange 2.5"/63.5 mm, IP65
- 7 = Square Flange 2.5"/63.5 mm, IP 67
- 8 = Servo Flange 2.5"/63.5 mm, IP67

## Shaft

- 1 = Ø6 mm x 10 mm
- 2 = Ø10 mm x 20 mm
- 3 = Ø1/4" mm x 7/8"
- 4 = Ø3/8" x 7/8"

## Input / Output Circuit

- 1 = 5 VDC / SSI or BiSS interface
- 2 = 10-30 VDC / SSI or BiSS interface
- 3 = 5 VDC / SSI or BiSS interface, and 2048 ppr SinCos
- 4 = 10-30 VDC / SSI or BiSS interface, and 2048 ppr SinCos(M23)
- 5 = 5 VDC / SSI or BiSS interface, with supply voltage monitoring output
- 6 = 5 VDC / SSI or BiSS interface, and 2048 ppr SinCos, with supply voltage monitoring output
- 7 = 5 VDC / SSI or BiSS and 2048 ppr-incremental track RS422 (TTL-comp.)
- 8 = 10-30 VDC / SSI or BiSS and 2048 ppr-incremental track RS422 (TTL-comp.)
- 9 = 5 VDC / SSI or BiSS and 2048 incremental track RS422 (TTL-comp.), with supply voltage monitoring output

- <sup>1)</sup> Status LED internally monitors encoder parameters such as; sensor condition, temperature, under and over voltage.
- <sup>2)</sup> Preset value, factory-programmable.
- <sup>3)</sup> Set and Direction are physical inputs for setting: 0 position (or any factory predefined value); controls rotation of shaft (CW/CCW) for increasing counts. Status output is discrete output linked to the LED status indicator.
- <sup>4)</sup> The Set button and Status LED are located on the rear of the encoder cover. Same functionality as SET control input, protected against accidental activation, can only be pushed in with the tip of a ballpoint pen or similar.

## Features / Benefits

- Update rate of 100 KHz for real time transmission
- Sinusoidal or square wave incremental signals (optional)
- SSI clock rate to 2Mhz
- BiSS clock rate to 10Mhz
- Captive bearings
- Wide temperature range

## Options <sup>1)</sup>

- 1 = No option
- 2 = Status LED
- 3 = Set button and status LED <sup>4)</sup>

## Input / Output <sup>3)</sup>

- 2 = SET, DIR Inputs and additional status output

## Resolution <sup>2)</sup>

- A = 10 bit + 12 bit
- 1 = 11 bit + 12 bit
- 2 = 12 bit + 12 bit
- 3 = 13 bit + 12 bit
- 4 = 14 bit + 12 bit
- 7 = 17 bit + 12 bit

## Code

- B = SSI, binary
- C = BiSS, binary
- G = SSI, gray

## Connection Type

- 1 = Axial cable, (PVC, 1 meter)
- 2 = Radial cable (PVC, 1 meter)
- 3 = Axial 12-pin, M23 (**multifast**<sup>®</sup>)
- 4 = Radial 12-pin, M23 (**multifast**<sup>®</sup>)
- 5 = Axial M12, 8-pin (**eurofast**<sup>®</sup>)
- 6 = Radial M12, 8-pin (**eurofast**<sup>®</sup>)

**Sendix® Absolute, Multiturn Shafted Type T8.5863 Specifications** **SSI, BiSS**

**Mechanical:**

- Max. Speed w/o Shaft sealing (IP 65)** . . . . 12000 RPM (Peak), 10000 RPM (Continuous) (up to 70°C)
- Max. Speed w/o Shaft sealing (IP 65)** . . . . 8000 RPM (Peak), 5000 RPM (Continuous) (up to Tmax)
- Max. Speed w/Shaft sealing (IP 67)** . . . . 11000 RPM (Peak), 9000 RPM (Continuous) (up to 70°C)
- Max. Speed w/Shaft sealing (IP 67)** . . . . 8000 RPM (Peak), 5000 RPM (Continuous) (up to Tmax)
- Protection Rating** . . . . . IP 65 (IP 67 with Shaft Seal)
- Operating Temperature<sup>1)</sup>** . . . . . -40° to +90°C (-40° to +194°F)
- Shock Resistance** . . . . . Up to 250 g
- Vibration Resistance** . . . . . Up to 100 g, 55-2000 Hz
- Humidity** . . . . . 98% Relative, Non-Condensing
- Weight** . . . . . Appr. .99 lbs
- Materials** . . . . . Shaft: Stainless Steel; Flange: Aluminum, Housing: Die-Cast Zinc, Cable: PVC
- Starting Torque w/o Shaft sealing (IP 65)** . . 1.42 oz.in.(<0.01Nm)
- Starting Torque w/Shaft sealing (IP 67)** . . . 7.08 oz.in.(<0.05Nm)

**General Electrical Characteristics:**

<b>Interface</b> . . . . .	<b>BiSS, SSI / 5 VDC</b> . . . . .	<b>BiSS, SSI / 10-30 VDC</b>
<b>Output Driver</b> . . . . .	RS 485 (Transceiver Type) . . . . .	RS 485 (Transceiver Type)
<b>Current Consumption (Typ./Max.)</b> . . . . .	70 mA @ VDC . . . . .	20 mA @ 24 VDC
<b>Load / Channel (Max.)</b> . . . . .	±20 mA . . . . .	±20 mA
<b>Signal Level High (Typ.)</b> . . . . .	3.8 V . . . . .	3.8 V
<b>Signal Level Low (Typ.)</b> . . . . .	1.3 V . . . . .	1.3 V
<b>Short-Circuit Proof<sup>2)</sup></b> . . . . .	Yes <sup>1)</sup> . . . . .	Yes <sup>1)</sup>
<b>Reverse Polarity Protection</b> . . . . .	No. . . . .	Yes

**Interface Characteristics SSI:**

- Singleturn Resolution** . . . . . 10-14 Bits and 17 Bits<sup>3)</sup>
- Code** . . . . . Binary or Gray
- SSI Clock Rate** . . . . . ≤14 bits: 50 kHz - 2 MHz
- Monoflop Time** . . . . . ≥15 μs<sup>3)</sup>
- Time Jitter (Data Request to Position Latch)** <1μs up to 14 bits  
≤4 μs at 15-17 bits
- Status and Parity Bit** . . . . . Optional on Request

**Note:** If clock starts cycling within monoflop time a second data transfer starts with the same data, double clocking is useful for data verification. If clock starts cycling after monoflop time the data transfer starts with updated values. Max. update rate is depending on clock speed, data length and monoflop-time.

<sup>1)</sup> Cable Versions: -30° to +75°C (-22° to 167°F).  
<sup>2)</sup> Short circuit to 0 V or to output, one channel at a time, supply voltage correctly applied.  
<sup>3)</sup> Other options upon request.

5863 SSI, BiSS

### Interface Characteristics BiSS:

Singleturn Resolution . . . . .	10-14 Bits and 17 Bits, Customer Programmable <sup>1)</sup>
Code . . . . .	Binary
Interfaces . . . . .	RS 485
Clock Rate. . . . .	Up to 10 MHz
Max. Update Rate. . . . .	<10 µs, Depending on Clock Speed and Data Length
Time Jitter (data request to position latch) . . . . .	≤1 µs

**Note:** Bidirectional, programmable parameters are: resolution, code, direction, alarms and warnings.  
Multicycle data output, e.g. for temperature.  
CRC data verification.

### SET (Zero or Defined Value) and DIRection (cw/ccw) Control Inputs:

Input Characteristic . . . . .	High Active
Receiver Type . . . . .	Comparator
Signal Level High . . . . .	Min. 60% of V+ (Supply Voltage), Max: V+
Signal Level Low. . . . .	Max. 25% of V+
Input Current . . . . .	≤0.5 mA
Min. Pulse Duration (SET) . . . . .	10 ms
Timeout After SET Input . . . . .	14 ms
Reaction Time (DIR Input). . . . .	1 ms

### Status Output:

Output Driver . . . . .	Open Collector, Internal Pull Up Resistor 22 k0hm
Permissible Load . . . . .	≤20 mA
Signal Level High . . . . .	V+
Signal Level Low. . . . .	<1 V
Active At. . . . .	Low

Optical sensor path faulty (code error, LED error), low voltage and overtemperature.

<sup>1)</sup> Other options upon request.

**Sendix® Absolute, Multiturn Shafted Type T8.5863 Specifications** **SSI, BiSS**

**Status LED (Red, Option):**

**LED on at** . . . . . Optical sensor path faulty (code error, LED error), low voltage and overtemperature

**SET Control Button (Zero or Defined Value, Option):**

Same functionality as SET control input, protected against accidental activation, can only be pushed in with the tip of a ballpoint pen or similar.

**Output Sine, Cosine, 2048 ppr (Option):**

	Sin/Cos	RS422 (TTL Compatible)
<b>-3dB Frequency</b> . . . . .	400 kHz . . . . .	400 kHz
<b>Signal Level</b> . . . . .	1 Vpp (± 20%) . . . . .	High: min 2.5 V Low: max. 0.5 V
<b>Short Circuit Proof</b> <sup>1)</sup> . . . . .	Yes . . . . .	Yes

<sup>1)</sup> Short-circuit to 0 V or to output, one channel at a time, supply voltage correctly applied.

5863 SSI, BiSS

#### Pinouts Notes 1), 2), 3)

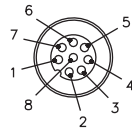
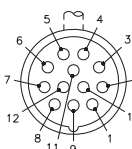
Male Encoder View	Mating Cordsets
<b>M12 Pinout</b> 	E-RKS 8T-264-*
<b>M23 Pinout (12-Pin)</b> 	E-CKM 12-1687-*/A

CCW

- 1) See cable section for additional options.
- 2) "S" denotes shield tied to coupling nut.
- 3) \* = length in meters, available in 0.1 meter increments  $\geq 0.2$  meters.

#### Standard Wiring / Pin Configuration

##### Output Circuit 1 or 2 and (2 Control Inputs, 1 Status Output)

(Connection 1,2,3 or 4)

Output	Common	+V	+Clock	-Clock	+Data	-Data	ST	DIR	Status	NC	NC	NC	PE
M23 Pin	1	2	3	4	5	6	7	8	9	10	11	12	PH
Color	WH	BN	GN	YE	GY	PK	BU	RD	BK	-	-	-	Shield

##### Output Circuit 5 and (2 Control Inputs, 1 Status Output, Voltage Monitor Outputs)

(Connection 1,2,3 or 4)

Output	Common	+V	+Clock	-Clock	+Data	-Data	ST	DIR	Status	NC	0 V Sens	+Ub Sens	PE
M23 Pin	1	2	3	4	5	6	7	8	9	10	11	12	PH
Color	WH	BN	GN	YE	GY	PK	BU	RD	BK	-	GY/PK	RD/BU	Shield

##### Output Circuit 3, 4, 7 or 8, and (2 Control Inputs, or Incremental Track, Sine/Cosine)

(Connection 1,2,3 or 4)

Output	Common	+V	+Clock	-Clock	+Data	-Data	ST	DIR	Sin A	Sin inv A-	Cos B	Cos inv B-	PE
M23 Pin	1	2	3	4	5	6	7	8	9	10	11	12	PH
Color	WH	BN	GN	YE	GY	PK	BU	RD	BK	VT	GY/PK	RD/BU	Shield

##### Output Circuit 6 or 9 and (Sine/Cosine, or Incremental Monitor, Voltage Outputs)

(Connection 1,2,3 or 4)

Output	Common	+V	+Clock	-Clock	+Data	-Data	Sin A	Sin inv A-	Cos B	Cos inv B-	0 V Sens	V+ Sens	PE
M23 Pin	1	2	3	4	5	6	7	8	9	10	11	12	PH
Color	WH	BN	GN	YE	GY	PK	BU	RD	BK	VT	GY/PK	RD/BU	Shield

##### Output Circuit 1 or 2 and (2 Control Inputs)

(Connection 5 or 6)

Output	Common	+V	+Clock	-Clock	+Data	-Data	SET	DIR	Shield/PE
M12 Pin	1	2	3	4	5	6	7	8	PH

**Sendix® Absolute, Multiturn Shafted Type T8.5863 Dimensions** **SSI, BiSS**

**T8.5863 Square Flanges 5 & 7  
Cable Connection 1 & 2**

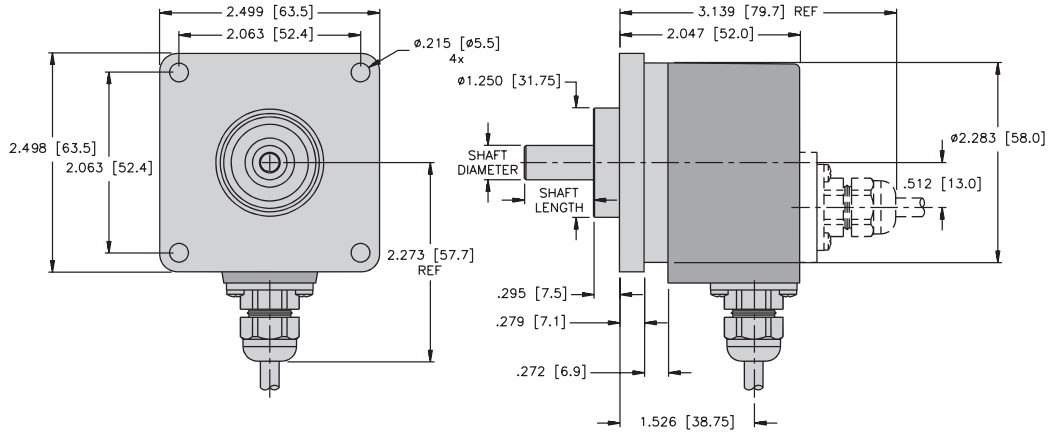

**T8.5863 Flanges 1 & 3  
M23 Connection 3 & 4**

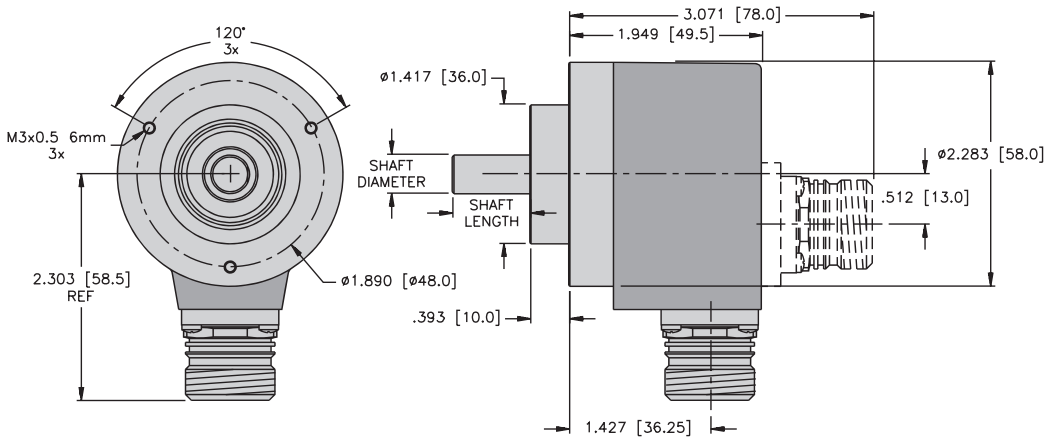

**T8.5863 Servo Flanges 2 & 4  
M12 Connection 5 & 6**

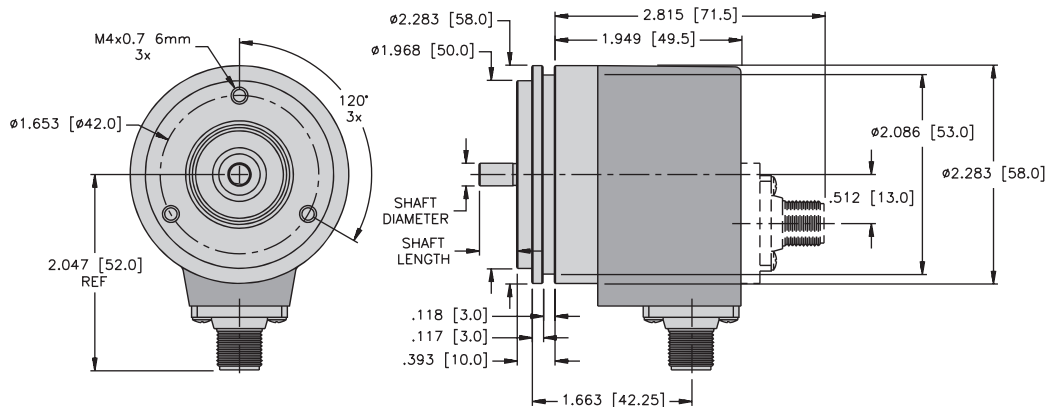

5863 SSI, BiSS

# Kübler by TURCK Absolute Encoders

**Sendix® Absolute, Multiturn Shafted Type T8.5868** **CANopen/CANlift**

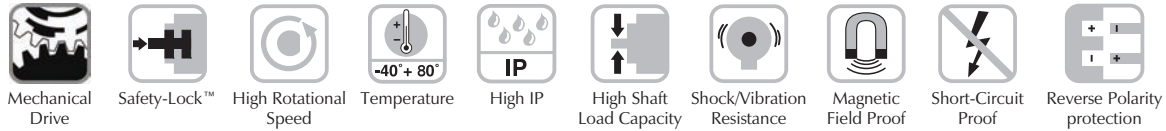

**T8. 5868. X X X X. XX1X.**

### Flange

- 1 = Clamping Flange Ø58 mm, IP 65
- 2 = Servo Flange Ø58 mm, IP 65
- 3 = Clamping Flange Ø58 mm, IP 67
- 4 = Servo Flange Ø58 mm, IP 67
- 5 = Square Flange 2.5"/63.5 mm, IP 65
- 6 = Servo Flange 2.5"/63.5 mm, IP 65
- 7 = Square Flange 2.5"/63.5 mm, IP 67
- 8 = Servo Flange 2.5"/63.5 mm, IP 67

### Shaft

- 1 = Ø6 mm x 10 mm
- 2 = Ø10 mm x 20 mm
- 3 = Ø1/4" mm x 7/8"
- 4 = Ø3/8" x 7/8"

### Input / Output Circuit

- 2 = 10-30 VDC CANopen DS 301 V4.02

### Options

- 2 = No option
- 3 = Set button

### Fieldbus Profile<sup>1)</sup>

- 21 = CANopen Encoder-Profile DS 406 V3.1
- 22 = CANlift DS 417 V1.01

### Connection Type

- 1 = Removable bus terminal cover, with radial screwed cable passage
- 2 = Removable bus terminal cover with 2 - M12 **euromast**® connectors
- A = Fixed connection without bus terminal cover with radial cable (PVC 2 meter)<sup>2)</sup>
- E = Fixed connection without bus terminal cover with 1 - M12 **euromast** radial connector<sup>2)</sup>
- F = Fixed connection without bus terminal cover with 2 - M12 **euromast** radial connectors<sup>2)</sup>
- I = Fixed connection without bus terminal cover with 1 - M23 **multifast**® radial connector<sup>2)</sup>
- J = Fixed connection without bus terminal cover with 2 - M23 **multifast** radial connectors<sup>2)</sup>
- K = Fixed connection without bus terminal cover with 1 - D-Sub 9-pin connector<sup>2)</sup>

<sup>1)</sup> CANopen parameters can also be factory preset. Please consult factory.  
<sup>2)</sup> Baud rate, address, and termination can not be set through dip-switches and must be configured via the bus program.

## Features / Benefits

- Captive bearings
- Wide temperature range
- Many connector styles; M12, fixed cover, removable cover, etc
- Heavy duty diecast cover
- Compact size
- High speed integrated OptoASIC
- High IP rating



**Sendix® Absolute, Multiturn Shafted Type T8.5868 Specifications** **CANopen/CANlift**

**Mechanical:**

- Max. Speed w/o Shaft sealing (IP 65)** . . . . 9000 RPM (Peak), 7000 RPM (Continuous) (up to 70°C)
- Max. Speed w/o Shaft sealing (IP 65)** . . . . 7000 RPM (Peak), 4000 RPM (Continuous) (up to Tmax)
- Max. Speed w/Shaft sealing (IP 67)** . . . . 8000 RPM (Peak), 6000 RPM (Continuous) (up to 70°C)
- Max. Speed w/Shaft sealing (IP 67)** . . . . 6000 RPM (Peak), 3000 RPM (Continuous) (up to Tmax)
- Protection Rating** . . . . . IP 65 (IP 67 with Shaft Seal)
- Operating Temperature**<sup>1)</sup> . . . . . -40° to +80°C (-40° to +176°F)
- Shock Resistance** . . . . . Up to 250 g
- Vibration Resistance** . . . . . Up to 100 g, 55-2000 Hz
- Humidity** . . . . . 98% Relative, Non-Condensing
- Weight** . . . . . Appr.1.26 lbs with Bus Terminal Cover; Appr. 1.45 lbs with Fixed Connection
- Materials** . . . . . Shaft: Stainless Steel; Flange: Aluminum, Housing: Die-Cast Zinc, Cable: PVC
- Starting Torque w/o Shaft sealing (IP 65)** . . 1.42 oz.in.(<0.01Nm)
- Starting Torque w/Shaft sealing (IP 67)** . . . 4.24 oz.in.(<0.03Nm)

<sup>1)</sup> Cable versions: -30° to +75°C (-22° to 167°F).

**General Electrical Characteristics:**

- Supply Voltage** . . . . . 10-30 VDC
- Current Consumption (w/o Output Load)** . Max. 65mA, 24 VDC
- Reverse Polarity**
- Protection at Power Supply** . . . . . Yes

Conforms to CE Requirements Acc. to EN 61000-6-1, EN61000-6-4 and EN 61000-6-3

**Interface Characteristics CANopen/CANlift:**

- Singleturn Resolution (Max., Scaleable)** . . 1-65536 (16 Bits), Default Scale value is Set to 8192 (13 Bits)
- Number of Revolutions** . . . . . 4096 (12 Bits), (Scaleable 1-4096)
- Code** . . . . . Binary
- Interface** . . . . . CAN High-Speed According ISO 11898, Basic - and Full-CAN, CAN Specification 2.0 B
- Protocol** . . . . . CANopen profile DS 406 V3.1 with Manufacturer-Specific Add-On's

**General Information About CANopen:**

The CANopen encoders of the 5868 series support the latest CANopen communication profile according to DS 301 V4.02. In addition, device-specific profiles like the encoder profile DS 406 V3.1 and the profile DS 417 V1.1 (for lift applications) are available. The following operating modes may be selected: Polled Mode, Cyclic Mode, Sync Mode and a High Resolution Sync Protocol. Additionally, scale factors, preset values, limit switch values and many other parameters can be programmed via the CANBus. When switching the device on, all parameters, which have been saved on an EEPROM to protect them against power failure, are reloaded. The following output values may be combined by PDO mapping: position, speed, acceleration, and status.

5868 CANopen/CANlift

## CANopen Communication Profile V4.02:

Among others, the following functionality is integrated:

Class C2 Functionality

- NMT slave
- Heartbeat protocol
- High resolution sync protocol identity object
- Error behavior object
- Variable PDO mapping self-start programmable (power on to operational), 3 sending PDO's
- 1 Receiving PDO for synchronous preset operation with minimal jitter
- Knot address, baud rate and CANbus
- Programmable termination

## CANopen Lift Profile DS 417 V1.1:

The following parameters can be programmed:

- Car position unit
- 2 virtual devices
- 1 virtual device delivers the position in absolute measuring steps (steps)
- 1 virtual device delivers the position in absolute travel information in mm
- Lift number programmable
- Independent setting of the knot address in relation with the CAN identifier
- Factor for speed calculation (e.g. measuring wheel periphery)
- Integration time for speed value of 1-32
- 2 work areas with 2 upper and lower limits and the corresponding output states
- Variable PDO mapping for position, speed, acceleration, work area, status
- Extended failure management for position sensing with integrated temperature control
- User interface with visual display of bus and failure status - 3 LED's

**Note:** All profiles stated here: Key-features.

The object 6003h "Preset" is assigned to an integrated key, accessible from the outside "Watchdog-controlled" device.

## SET Control Button (Zero or Defined Value, Option):

Protected against accidental activation, can only be pushed in with the tip of a ballpoint pen or similar.

## Diagnostic LED (Yellow):

**LED on at** . . . . . Optical sensor path faulty (code error, LED error), low voltage and overtemperature or CANlift profile DS 417 V1.1

## Protocol:

**Baud Rate** . . . . . 10-1000 kbits/s (Set by DIP Switches/Software Configurable)

**Node Address** . . . . . 1-127 (Set by Rotary Switches/Software Configurable)

**Termination Switchable** . . . . . Set by DIP Switches, Software Configurable

Price conscience encoders are available with optional connectors or cable connections in place of the costlier removable terminal box versions. Additionally, these encoders do not have user accessible DIP switches and require the user to program the address and baud rate through the software.

The models with the terminal cover include an integrated T-shaped coupler with the bus and power connections utilizing simple M12 connectors. The device address is set with two rotary switches while a bank of DIP switches set the baud rate and also allows the connection of a termination resistor.

Finally, all versions include three LED's located on the rear of the housing to indicate the status of the CAN bus as well as the status of the internal diagnostics.

**Sendix® Absolute, Multiturn Shafted Type T8.5868 Specifications** **CANopen/CANlift**

**Pinouts** Notes 1), 2), 3)

A Male Encoder View	B Female Encoder View	C Male Encoder View
CCW		
<b>Bus In and Out M23</b>	<b>Bus Out M12 Pinout</b>	<b>Bus In M12 Pinout</b>
<b>Mating Cordset</b>	<b>Mating Cordset</b>	<b>Mating Cordset</b>
Consult Factory	RSC 572-*M	RKC 572-*M

- 1) See cable section for additional options.
- 2) "S" denotes shield tied to coupling nut.
- 3) \* = length in meters, available in 0.1 meter increments  $\geq 0.2$  meters.

**Standard Wiring / Pin Configuration**

**Bus Terminal Cover with Terminal Box**

(Connection 1)

Direction	OUT					IN				
Signal:	CAN Ground	CAN_Low (-)	CAN_High (+)	0 VOLT Power Supply	+VOLT Power Supply	0 VOLT Power Supply	+VOLT Power Supply	CAN_Low (-)	CAN_High (+)	CAN Ground
Abbreviation:	CG	CL	CH	0 V	+V	0 V	+V	CL	CH	CG

**Cable Connection**

(Connection A)

Direction	IN				
Signal:	0 VOLT Power Supply	+VOLT Power Supply	CAN_Low (-)	CAN_High (+)	CAN Ground
Abbreviation:	0 V	+V	CL	CH	CG
Cable Color	BK	RD	BL	WH	GY

**M23 Connector, M12 Connector or D-Sub 9**

(Connection I) (Connection E) (Connection K)

Direction	IN					Pinout
Signal:	0 VOLT Power Supply	+VOLT Power Supply	CAN_Low (-)	CAN_High (+)	CAN Ground	
Abbreviation:	0 V	+V	CL	CH	CG	
M23 PIN Assignment:	10	12	2	7	3	A
M12 PIN Assignment:	3	2	5	4	1	C
D-Sub 9	6	9	2	7	3	-

**Bus Terminal Cover with 2 - M12, 2 - M12, 2 - M23**

(Connection 2) (Connection F) (Connection J)

Direction	OUT					Pinout	IN					Pinout
Signal:	CAN Ground	CAN_Low (-)	CAN_High (+)	0 VOLT Power Supply	+VOLT Power Supply		0 VOLT Power Supply	+VOLT Power Supply	CAN_Low (-)	CAN_High (+)	CAN Ground	
Abbreviation:	CG	CL	CH	0 V	+V		0 V	+V	CL	CH	CG	
M23 PIN Assignment:	3	2	7	10	12	A	10	12	2	7	3	A
M12 PIN Assignment:	1	5	4	3	2	B	3	2	5	4	1	C

5868 CANopen/CANlift

**T8.5868 Square Flanges 5 & 7  
Cable Connection 1**

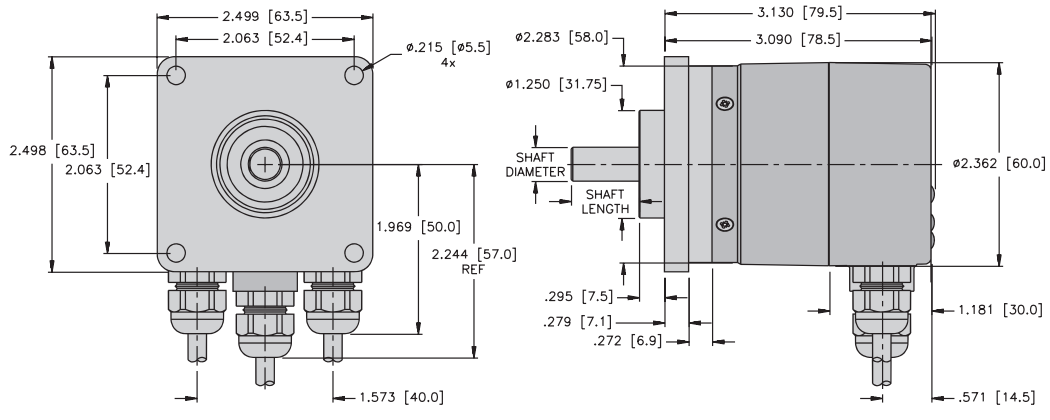

**T8.5868 Clamping Flanges 1 & 3  
M12 Connection 2**

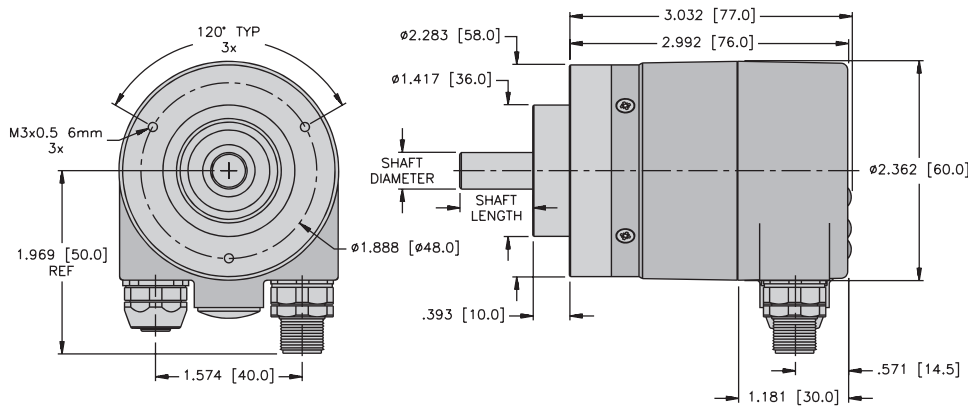

**T8.5868 Clamping Flanges 1 & 3  
Cable Connection A**

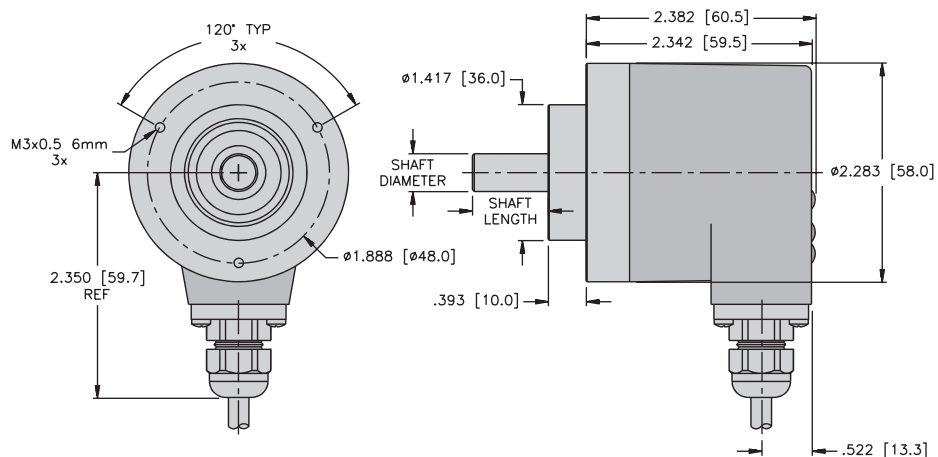

**Sendix® Absolute, Multiturn Shafted Type T8.5868 Dimensions** **CANopen/CANlift**

**T8.5868 Clamping Flanges 1 & 3  
M12 Connection E**

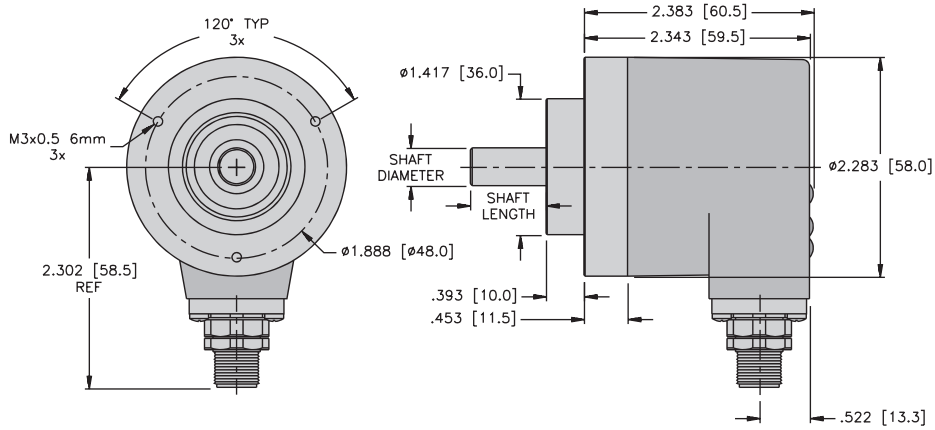

**T8.5868 Servo Flanges 2 & 4  
M12 Connection F**

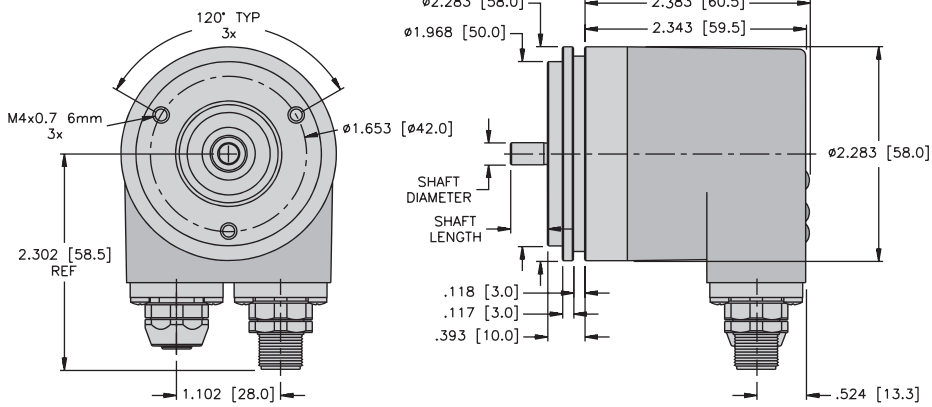

**T8.5868 Servo Flanges 2 & 4  
M23 Connection I**

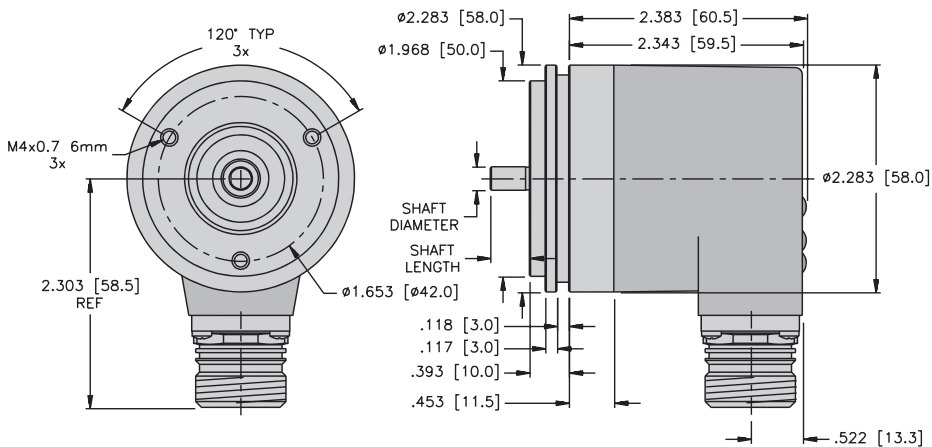

5868 CANopen/CANlift

**T8.5868 Square Flanges 5 & 7  
M23 Connection J**

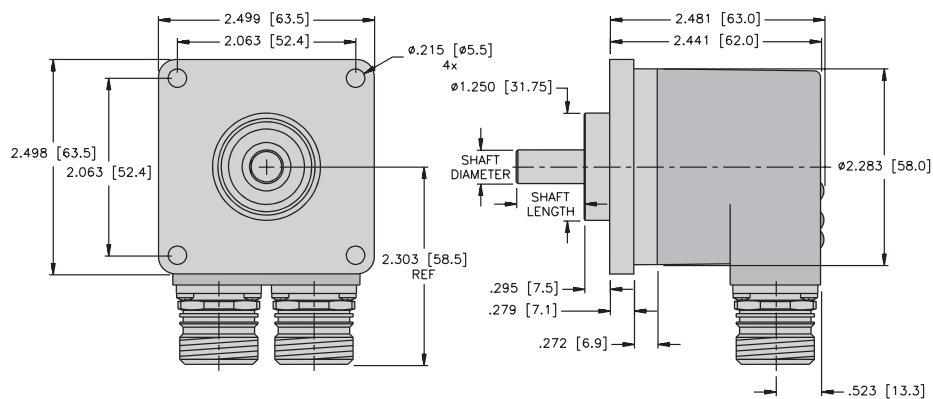

**T8.5868 Servo Flanges 2 & 4  
D-Sub Connection K**

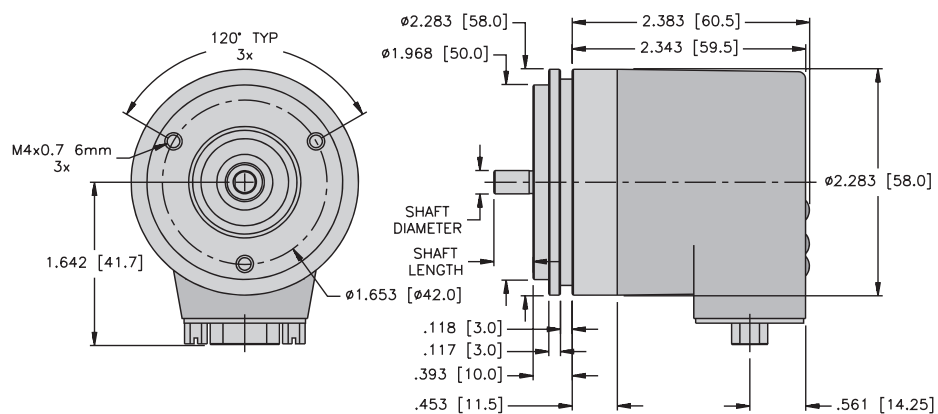

**Sendix® Absolute, Multiturn Shafted Type T8.5868 PROFIBUS®-DP**



- Mechanical Drive
- Safety-Lock™
- High Rotational Speed
- Temperature  
-40°+ 80°
- High IP
- High Shaft Load Capacity
- Shock/Vibration Resistance
- Magnetic Field Proof
- Short-Circuit Proof
- Reverse Polarity protection

**T8. 5868. X X X X. XX1X.**

**Flange**

- 1 = Clamping Flange Ø58 mm, IP 65
- 2 = Servo Flange Ø58 mm, IP 65
- 3 = Clamping Flange Ø58 mm, IP 67
- 4 = Servo Flange Ø58 mm, IP 67
- 5 = Square Flange 2.5"/63.5 mm, IP 65
- 6 = Servo Flange 2.5"/63.5 mm, IP 65
- 7 = Square Flange 2.5"/63.5 mm, IP 67
- 8 = Servo Flange 2.5"/63.5 mm, IP 67

**Shaft**

- 1 = Ø6 mm x 10 mm
- 2 = Ø10 mm x 20 mm
- 3 = Ø1/4" mm x 7/8"
- 4 = Ø3/8" x 7/8"

**Input / Output Circuit**

- 3 = 10-30 PROFIBUS-DP V0 Encoder Profile V 1.1

**Options**

- 2 = No option
- 3 = Set button

**Fieldbus Profile**

- 31 = PROFIBUS-DP-V0  
Encoder Profile Class 2

**Connection Type**

- 1 = Removable bus terminal cover, with radial screwed cable passage
- 2 = Removable bus terminal cover with 3 - M12 **euromast**® connectors

**Features / Benefits**

- Captive bearings
- Wide temperature range
- Removable terminal box with M12 connector and cable versions
- Heavy duty diecast cover
- Compact size
- High speed integrated OptoASIC
- High IP rating

5868 PROFIBUS®-DP

# Kübler by TURCK

## Absolute Encoders

**Sendix** Absolute, Multiturn Shafted Type T8.5868 Specifications

**PROFIBUS**®-DP

### Mechanical:

<b>Max. Speed w/o Shaft sealing (IP 65)</b>	. . . . . 9000 RPM (Peak), 7000 RPM (Continuous) (up to 70°C)
<b>Max. Speed w/o Shaft sealing (IP 65)</b>	. . . . . 7000 RPM (Peak), 4000 RPM (Continuous) (up to Tmax)
<b>Max. Speed w/Shaft sealing (IP 67)</b>	. . . . . 8000 RPM (Peak), 6000 RPM (Continuous) (up to 70°C)
<b>Max. Speed w/Shaft sealing (IP 67)</b>	. . . . . 6000 RPM (Peak), 3000 RPM (Continuous) (up to Tmax)
<b>Protection Rating</b>	. . . . . IP 65 (IP 67 with Shaft Seal)
<b>Operating Temperature</b> <sup>1)</sup>	. . . . . -40° to +80°C (-40° to +176°F)
<b>Shock Resistance</b>	. . . . . Up to 250 g
<b>Vibration Resistance</b>	. . . . . Up to 100 g, 55-2000 Hz
<b>Humidity</b>	. . . . . 98% Relative, Non-Condensing
<b>Weight</b>	. . . . . Appr.1.26 lbs with Bus Terminal Cover; Appr. 1.45 lbs with Fixed Connection
<b>Materials</b>	. . . . . Shaft: Stainless Steel; Flange: Aluminum, Housing: Die-Cast Zinc, Cable: PVC
<b>Starting Torque w/o Shaft sealing (IP 65)</b>	. . . . . 1.42 oz.in.(<0.01Nm)
<b>Starting Torque w/Shaft sealing (IP 67)</b>	. . . . . 4.24 oz.in.(<0.03Nm)

<sup>1)</sup> Cable versions: -30° to +75°C (-22° to 167°F).

### General Electrical Characteristics:

<b>Supply Voltage</b>	. . . . . 10-30 VDC
<b>Current Consumption (w/o Output Load)</b>	. . . . . Max. 90 mA, 24 VDC
<b>Reverse Polarity</b>	
<b>Protection at Power Supply</b>	. . . . . Yes

Conforms to CE Requirements Acc. to EN 61000-6-1, EN61000-6-4 and EN 61000-6-3

### Interface Characteristics PROFIBUS-DP:

<b>Singleturn Resolution (Max., Scaleable)</b>	. . . . . 1-65536 (16 Bits), Default Scale value is Set to 8192 (13 Bits)
<b>Total Resolution</b>	. . . . . 28 Bit (scaleable 1-2 <sup>28</sup> steps)
<b>Number of Revolutions</b>	. . . . . 4096 (12 Bits), (Scaleable 1-4096)
<b>Code</b>	. . . . . Binary
<b>Interface</b>	. . . . . Specifications According to PROFIBUS-DP 2.0 Standard RS-485 Driver Galvanically Isolated
<b>Protocol</b>	. . . . . PROFIBUS Encoder Profile V1.1 Class 1 and Class 2 with Manufacturer-specific Enhancements

### PROFIBUS Encoder Profile V1.1

The PROFIBUS-DP device profile describes the functionality of the communication and the user-specific component within the PROFIBUS field bus system. For encoders, the encoder profile is definitive. Here the individual objects are defined independent of the manufacturer. Furthermore, the profiles offer space for additional manufacturer-specific functions; this means that PROFIBUS-compliant device systems can be used now with the guarantee that they are ready for the future too.



**Sendix® Absolute, Multiturn Shafted Type T8.5868 Specifications** **PROFIBUS® -DP**

**The Following Parameters Can Be Programmed:**

- Direction of rotation
- Scaling
- Number of steps per revolution
- Number of revolutions
- Total revolution over Singleturn/Multiturn
- Preset value
- Diagnostics mode

**SET Control Button (Zero or Defined Value, Option):**

Protected against accidental activation, can only be pushed in with the tip of a ballpoint pen or similar.

**Diagnostic LED (yellow):**

**LED on at** . . . . . Optical sensor path faulty (code error, LED error), low voltage and overtemperature

**Protocol**

- Baud Rate** . . . . . 12 Mbits/s
- Node Address** . . . . . 1-127 (Set by Rotary Switches)
- Termination Switchable** . . . . . Set by DIP Switches, Software Configurable

**The Following Functionality Is Integrated:**

- Galvanic isolation of the bus stage with DC/DC converter
- Line driver acc. to RS 485 max. 12 MB
- Address programmable via DIP switches
- Diagnostics LED
- Full class 1 and class 2 functionality

5868 PROFIBUS® -DP

Standard Wiring / Pin Configuration

Terminal Assignment with Terminal Box

(Connection 1)

Signal:	BUS IN				BUS OUT			
	B	A	0 V	+V	0 V	+V	B	A
Pin:	1	2	3	4	5	6	7	8

Terminal Assignment M12 - 3 Connector Version

(Connection 2)

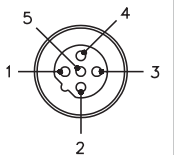
	Signal:	-	BUS-A	-	BUS-B	Shield	Male Pinout	Mating Cordsets <sup>2), 3), 4)</sup>
Bus In	Pin:	1	2	3	4	5		RKSW-455-*M

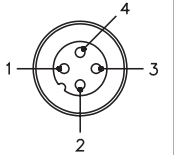
	Signal:	U <sub>B</sub>	-	0 V	-	Male Pinout	Mating Cordsets <sup>2), 4)</sup>
Power Supply	Pin:	1	2	3	4		RK 4.4T-*

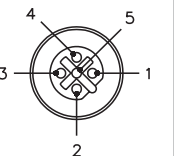
	Signal:	BUS-VDC <sup>1)</sup>	BUS-A	BUS_GND <sup>1)</sup>	BUS-B	Shield	Female Pinout	Mating Cordsets <sup>2), 3), 4)</sup>
Bus Out	Pin:	1	2	3	4	5		RSSW-455-*M

<sup>1)</sup> For powering an external PROFIBUS-DP terminating resistor.  
<sup>2)</sup> See cable section for additional options.  
<sup>3)</sup> "S" denotes shield tied to coupling nut.  
<sup>4)</sup> \* = length in meters, available in 0.1 meters increments ≥0.2 meters.

**Sendix® Absolute, Multiturn Shafted Type T8.5868 Dimensions PROFIBUS® -DP**

**T8.5868 Square Flanges 5 & 7  
Cable Connection 1**

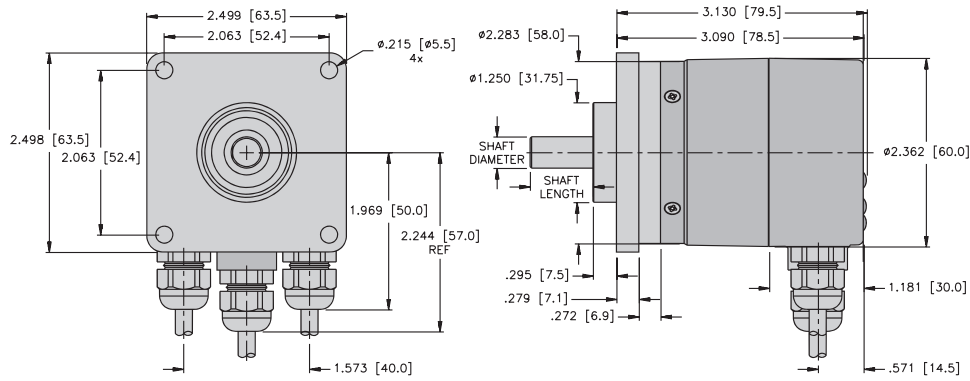

**T8.5868 Servo Flanges 2 & 4  
Cable Connection 1**

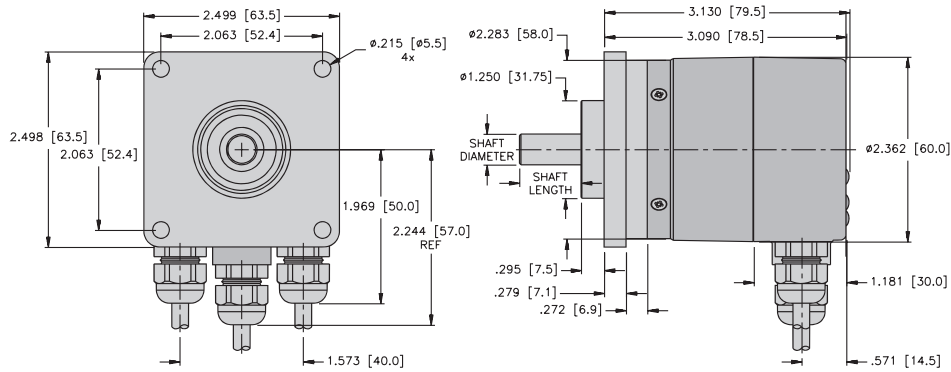

**T8.5868 Clamping Flanges 1 & 3  
M12 Connection 2**

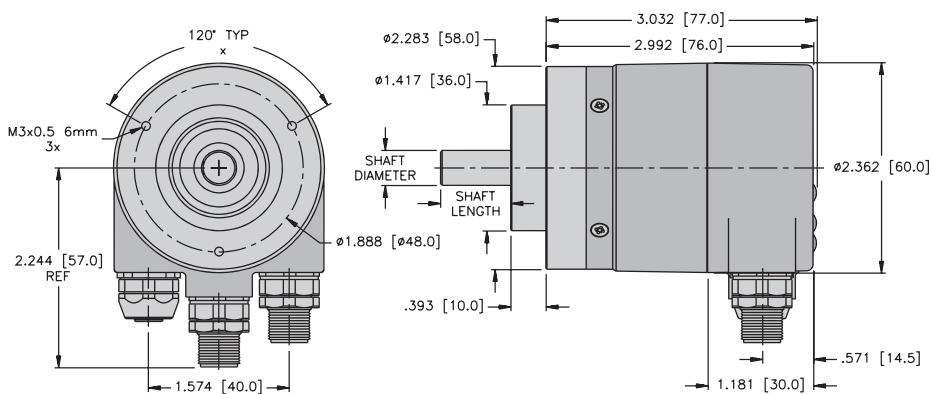

5868 PROFIBUS® -DP

# Kübler by TURCK Absolute Encoders

**Sendix** Absolute, Multiturn Hollow Shaft Type T8.5883

SSI, BiSS



Mechanical Drive



Safety-Lock™



High Rotational Speed



Temperature  
-40° +90°



High IP



High Shaft Load Capacity



Shock/Vibration Resistance



Magnetic Field Proof



Short-Circuit Proof



Reverse Polarity protection



SIN/COS

**T8. 5883. X X X X. XXXX.**

## Flange

- 1 = Flange with torque stop IP 65
- 2 = Flange with torque stop IP 67
- 3 = Flange with stator coupling pitch circle Ø 65, IP 65
- 4 = Flange with stator coupling pitch circle Ø 65, IP 67
- 5 = Flange with stator coupling pitch circle Ø 63, IP 65
- 6 = Flange with stator coupling pitch circle Ø 63, IP 67

## Hollow Shaft

- 3 = Ø10 mm
- 4 = Ø12 mm
- 5 = Ø14 mm
- 6 = Ø15 mm (blind hub shaft)
- 8 = Ø9.52 mm [3/8"]
- 9 = Ø12.7 mm [1/2"]

## Input / Output Circuit

- 1 = 5 VDC / SSI or BiSS interface
- 2 = 10-30 VDC / SSI or BiSS interface
- 3 = 5 VDC / SSI or BiSS interface, and 2048 ppr SinCos
- 4 = 10-30 VDC / SSI or BiSS interface, and 2048 ppr SinCos(M23)
- 5 = 5 VDC / SSI or BiSS interface, with supply voltage monitoring output
- 6 = 5 VDC / SSI or BiSS interface, and 2048 ppr SinCos, with supply voltage monitoring output
- 7 = 5 VDC / SSI or BiSS and 2048 ppr-incremental track RS422 (TTL-comp.)
- 8 = 10-30 VDC / SSI or BiSS and 2048 ppr-incremental track RS422 (TTL-comp.)
- 9 = 5 VDC / SSI or BiSS and 2048 incremental track RS422 (TTL-comp.), with supply voltage monitoring output

## Options<sup>1)</sup>

- 1 = No option
- 2 = Status LED
- 3 = Set button and status LED<sup>4)</sup>

## Input / Output<sup>3)</sup>

- 2 = SET, DIR Inputs and additional status output

## Resolution<sup>2)</sup>

- A = 10 bit + 12 bit
- 1 = 11 bit + 12 bit
- 2 = 12 bit + 12 bit
- 3 = 13 bit + 12 bit
- 4 = 14 bit + 12 bit
- 7 = 17 bit + 12 bit

## Code

- B = SSI, binary
- C = BiSS, binary
- G = SSI, gray

## Connection Type

- 2 = Radial cable (PVC, 1 meter)
- 4 = Radial 12-pin, M23 (**multifast**®)
- 6 = Radial M12, 8-pin (**eurofast**®)

<sup>1)</sup> Status LED internally monitors encoder parameters such as; sensor condition, temperature, under and over voltage.  
<sup>2)</sup> Preset value, factory-programmable.  
<sup>3)</sup> Set and Direction are physical inputs for setting: 0 position (or any factory predefined value); controls rotation of shaft (CW/CCW) for increasing counts. Status output is discrete output linked to the LED status indicator.  
<sup>4)</sup> The Set button and Status LED are located on the rear of the encoder cover. Same functionality as SET control input, protected against accidental activation, can only be pushed in with the tip of a ballpoint pen or similar.

## Features / Benefits

- Update rate of 100 KHz for real time transmission
- Sinusoidal or square wave incremental signals (optional)
- SSI clock rate to 2Mhz
- BiSS clock rate to 10Mhz
- Captive bearings
- Wide temperature range

**Sendix® Absolute, Multiturn Hollow Shaft Type T8.5883 Specifications** **SSI, BiSS**

**Mechanical:**

- Max. Speed w/o Shaft sealing (IP 65) . . . . 9000 RPM (Peak), 6000 RPM (Continuous) (up to 70°C)
- Max. Speed w/o Shaft sealing (IP 65) . . . . 6000 RPM (Peak), 3000 RPM (Continuous) (up to Tmax)
- Max. Speed w/Shaft sealing (IP 67) . . . . 8000 RPM (Peak), 4000 RPM (Continuous) (up to 70°C)
- Max. Speed w/Shaft sealing (IP 67) . . . . 4000 RPM (Peak), 2000 RPM (Continuous) (up to Tmax)
- Protection Rating . . . . . IP 65 (IP 67 with Shaft Seal)
- Operating Temperature<sup>1)</sup> . . . . . -40° to +90°C (-40° to +194°F)
- Shock Resistance . . . . . Up to 250 g
- Vibration Resistance . . . . . Up to 100 g, 55-2000 Hz
- Humidity . . . . . 98% Relative, Non-Condensing
- Weight . . . . . Appr. 0.99 lbs
- Materials . . . . . Shaft: Stainless Steel; Flange: Aluminum, Housing: Die-Cast Zinc, Cable: PVC
- Starting Torque w/o Shaft sealing (IP 65) . . . . 4.24 oz.in.(<0.03Nm)
- Starting Torque w/Shaft sealing (IP 67) . . . . 7.08 oz.in.(<0.05Nm)

**General Electrical Characteristics:**

Interface . . . . .	<b>BiSS, SSI / 5 VDC</b> . . . . .	<b>BiSS, SSI / 10-30 VDC</b>
Output Driver . . . . .	RS 485 (Transceiver Type) . . . . .	RS 485 (Transceiver Type)
Current Consumption (Typ./Max.) . . . . .	70 mA @ SVDC . . . . .	20 mA @ 24 VDC
Load / Channel (Max.) . . . . .	±20 mA . . . . .	±20 mA
Signal Level High (Typ.) . . . . .	3.8 V . . . . .	3.8 V
Signal Level Low (Typ.) . . . . .	1.3 V . . . . .	1.3 V
Short-Circuit Proof <sup>2)</sup> . . . . .	Yes . . . . .	Yes
Reverse Polarity Protection . . . . .	No. . . . .	Yes

**Interface Characteristics SSI:**

- Singleturn Resolution . . . . . 10-14 Bits and 17 Bits<sup>3)</sup>
- Code . . . . . Binary or Gray
- SSI Clock Rate . . . . . ≤14 bits: 50 kHz - 2 MHz
- Monoflop Time . . . . . ≥15 μs<sup>3)</sup>
- Time Jitter (Data Request to Position Latch) <1μs up to 14 bits  
≤4 μs at 15-17 bits
- Status and Parity Bit . . . . . Optional on Request

**Note:** If clock starts cycling within monoflop time a second data transfer starts with the same data, double clocking is useful for data verification. If clock starts cycling after monoflop time the data transfer starts with updated values. Max. update rate is depending on clock speed, data length and monoflop-time.

<sup>1)</sup> Cable Versions: -30° to +75°C (-22° to 167°F).  
<sup>2)</sup> Short circuit to 0V or to output, one channel at a time, supply voltage correctly applied.  
<sup>3)</sup> Other options upon request.

5883 SSI, BiSS

## Interface Characteristics BiSS:

Singleturn Resolution . . . . .	10-14 Bits and 17 Bits, Customer Programmable <sup>1)</sup>
Code . . . . .	Binary
Interfaces . . . . .	RS 485
Clock Rate. . . . .	Up to 10 MHz
Max. Update Rate . . . . .	<10 µs, Depending on Clock Speed and Data Length
Time Jitter (data request to position latch) . . . . .	≤1 µs

### Note:

Bidirectional, programmable parameters are: resolution, code, direction, alarms and warnings.  
Multicycle data output, e.g. for temperature.  
CRC data verification.

## SET (Zero or Defined Value) and DIRection (cw/ccw) Control Inputs:

Input Characteristic . . . . .	High Active
Receiver Type . . . . .	Comparator
Signal Level High . . . . .	Min. 60% of V+ (Supply Voltage), Max: V+
Signal Level Low. . . . .	Max. 25% of V+
Input Current . . . . .	≤0.5 mA
Min. Pulse Duration (SET) . . . . .	10 ms
Timeout After SET Input . . . . .	14 ms
Reaction Time (DIR Input). . . . .	1 ms

## Status Output:

Output Driver . . . . .	Open Collector, Internal Pull Up Resistor 22 kΩ
Permissible Load . . . . .	≤20 mA
Signal Level High . . . . .	V+
Signal Level Low. . . . .	<1 V
Active At. . . . .	Low

Optical sensor path faulty (code error, LED error), low voltage and overtemperature.

<sup>1)</sup> Other options upon request.

**Sendix® Absolute, Multiturn Hollow Shaft Type T8.5883 Specifications** **SSI, BiSS**

**Status LED (Red, Option):**

LED on at . . . . . Optical sensor path faulty (code error, LED error), low voltage and overtemperature

**SET Control Button (Zero or Defined Value, Option):**

Same functionality as SET control input, protected against accidental activation, can only be pushed in with the tip of a ballpoint pen or similar.

**Output Sine, Cosine, 2048 ppr (Option):**

	Sin/Cos	RS422 (TTL Compatible)
-3dB Frequency . . . . .	400 kHz . . . . .	400 kHz
Signal Level . . . . .	1 Vpp (± 20%) . . . . .	High: min 2.5 V Low: max. 0.5 V
Short-Circuit Proof <sup>1)</sup> . . . . .	Yes . . . . .	Yes

<sup>1)</sup> Short-circuit to 0V or to output, one channel at a time, supply voltage correctly applied.

5883 SSI, BiSS

#### Pinouts Notes 1), 2), 3)

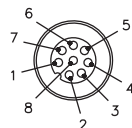
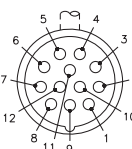
Male Encoder View	Mating Cordsets
<p><b>M12 Pinout</b></p> 	E-RKS 8T-264-*
<p><b>M23 Pinout (12-Pin)</b></p>  <p>CCW</p>	E-CKM 12-1687-*/A

- 1) See cable section for additional options.
- 2) "S" denotes shield tied to coupling nut.
- 3) \* = length in meters, available in 0.1 meter increments  $\geq 0.2$  meters.

#### Standard Wiring / Pin Configuration

##### Output Circuit 1 or 2 and (2 Control Inputs, 1 Status Output)

(Connection 1,2,3 or 4)

Output	Common	+V	+Clock	-Clock	+Data	-Data	ST	DIR	Status	NC	NC	NC	PE
M23 Pin	1	2	3	4	5	6	7	8	9	10	11	12	PH
Color	WH	BN	GN	YE	GY	PK	BU	RD	BK	-	-	-	Shield

##### Output Circuit 5 and (2 Control Inputs, 1 Status Output, Voltage Monitor Outputs)

(Connection 1,2,3 or 4)

Output	Common	+V	+Clock	-Clock	+Data	-Data	ST	DIR	Status	NC	0 V Sens	+Ub Sens	PE
M23 Pin	1	2	3	4	5	6	7	8	9	10	11	12	PH
Color	WH	BN	GN	YE	GY	PK	BU	RD	BK	-	GY/PK	RD/BU	Shield

##### Output Circuit 3, 4, 7 or 8, and (2 Control Inputs, or Incremental Track, Sine/Cosine)

(Connection 1,2,3 or 4)

Output	Common	+V	+Clock	-Clock	+Data	-Data	ST	DIR	Sin A	Sin inv A-	Cos B	Cos inv B-	PE
M23 Pin	1	2	3	4	5	6	7	8	9	10	11	12	PH
Color	WH	BN	GN	YE	GY	PK	BU	RD	BK	VT	GY/PK	RD/BU	Shield

##### Output Circuit 6 or 9 and (Sine/Cosine, or Incremental Monitor, Voltage Outputs)

(Connection 1,2,3 or 4)

Output	Common	+V	+Clock	-Clock	+Data	-Data	Sin A	Sin inv A-	Cos B	Cos inv B-	0 V Sens	V+ Sens	PE
M23 Pin	1	2	3	4	5	6	7	8	9	10	11	12	PH
Color	WH	BN	GN	YE	GY	PK	BU	RD	BK	VT	GY/PK	RD/BU	Shield

##### Output Circuit 1 or 2 and (2 Control Inputs)

(Connection 5 or 6)

Output	Common	+V	+Clock	-Clock	+Data	-Data	SET	DIR	Shield/PE
M12 Pin	1	2	3	4	5	6	7	8	PH



**Sendix® Absolute, Multiturn Hollow Shaft Type T8.5883 Dimensions** **SSI, BiSS**

**T8.5883 Flanges 3 & 4  
Cable Connection 2**

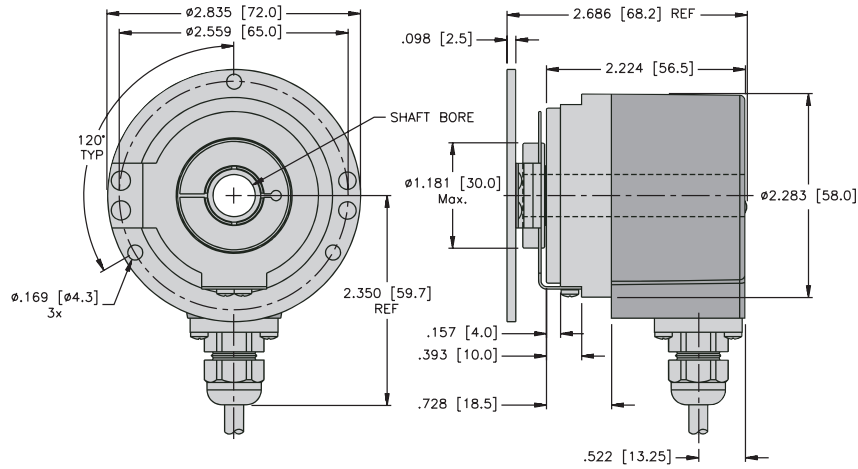

**T8.5883 Flanges 5 & 6  
M23 Connection 4**

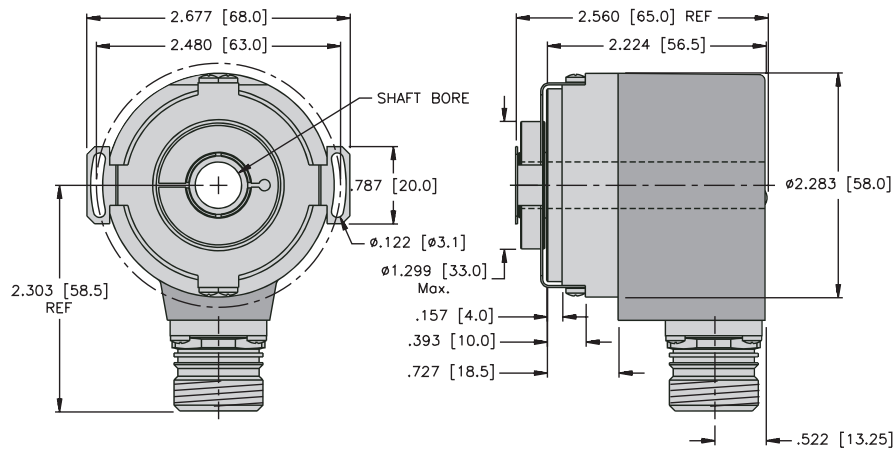

**T8.5883 Flanges 1 & 2  
M12 Connection 6**

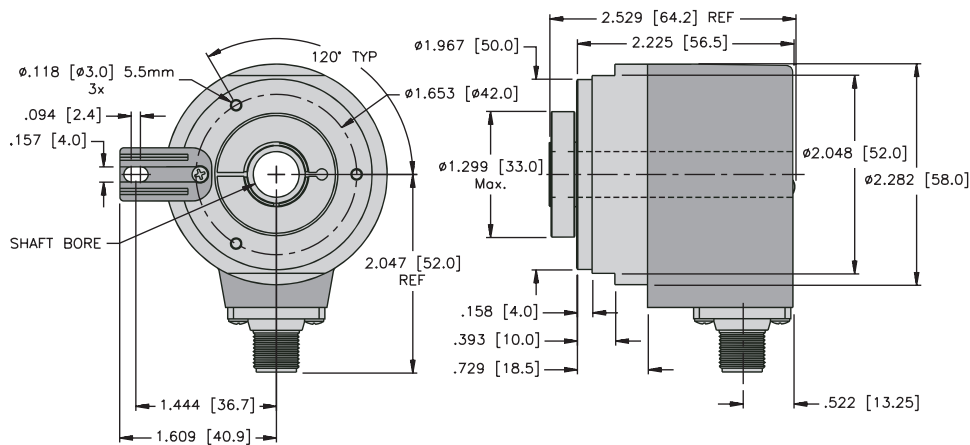

5883 SSI, BiSS

# Kübler by TURCK Absolute Encoders

**Sendix** Absolute, Multiturn Hub Shaft Type T8.5888 **CANopen/CANlift**

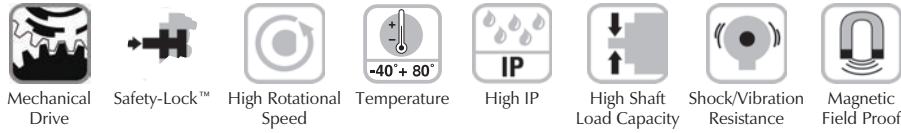

**T8. 5888. X X X X. XX1X.**

### Flange

- 1 = Flange with torque stop IP 65
- 2 = Flange with torque stop IP 67
- 3 = Flange with stator coupling pitch circle Ø 65, IP 65
- 4 = Flange with stator coupling pitch circle Ø 65, IP 67
- 5 = Flange with stator coupling pitch circle Ø 63, IP 65
- 6 = Flange with stator coupling pitch circle Ø 63, IP 67

### Blind Hub Shaft

- 3 = Ø10 mm
- 4 = Ø12 mm
- 5 = Ø14 mm
- 6 = Ø15 mm
- 8 = Ø9.52 mm [3/8"]
- 9 = Ø12.7 mm [1/2"]

### Input / Output Circuit

- 2 = 10-30 VDC CANopen DS 301 V4.02

### Options

- 2 = No option
- 3 = Set button

### Fieldbus Profile <sup>1)</sup>

- 21 = CANopen Encoder-Profile DS 406 V3.1
- 22 = CANlift DS 417 V1.01

### Connection Type

- 1 = Removable bus terminal cover, with radial screwed cable passage
- 2 = Removable bus terminal cover with 2 - M12 **euromast**® connectors
- A = Fixed connection without bus terminal cover with radial cable (PVC 2 meter) <sup>2)</sup>
- E = Fixed connection without bus terminal cover with 1 - M12 **euromast** radial connector <sup>2)</sup>
- F = Fixed connection without bus terminal cover with 2 - M12 **euromast** radial connectors <sup>2)</sup>
- I = Fixed connection without bus terminal cover with 1 - M23 **multifast**® radial connector <sup>2)</sup>
- J = Fixed connection without bus terminal cover with 2 - M23 **multifast** radial connectors <sup>2)</sup>
- K = Fixed connection without bus terminal cover with 1 - D-Sub 9-pin connector <sup>2)</sup>

<sup>1)</sup> CANopen parameters can also be factory preset. Please consult factory.  
<sup>2)</sup> Baud rate, address, and termination can not be set through dip-switches and must be configured via the bus program.

## Features / Benefits

- Captive bearings
- Wide temperature range
- Many connector styles; M12, fixed cover, removable cover, etc
- Heavy duty diecast cover
- Compact size
- High speed integrated OptoASIC
- High IP rating

**Sendix® Absolute, Multiturn Hub Shaft Type T8.5888 Specifications** **CANopen/CANlift**

**Mechanical:**

- Max. Speed w/o Shaft sealing (IP 65)** . . . . 9000 RPM (Peak), 7000 RPM (Continuous) (up to 70°C)
- Max. Speed w/o Shaft sealing (IP 65)** . . . . 7000 RPM (Peak), 4000 RPM (Continuous) (up to Tmax)
- Max. Speed w/Shaft sealing (IP 67)** . . . . 8000 RPM (Peak), 6000 RPM (Continuous) (up to 70°C)
- Max. Speed w/Shaft sealing (IP 67)** . . . . 6000 RPM (Peak), 3000 RPM (Continuous) (up to Tmax)
- Protection Rating** . . . . . IP 65 (IP 67 with Shaft Seal)
- Operating Temperature** <sup>1)</sup> . . . . . -40° to +80°C (-40° to +176°F)
- Shock Resistance** . . . . . Up to 250g
- Vibration Resistance** . . . . . Up to 100g, 55-2000 Hz
- Humidity** . . . . . 98% Relative, Non-Condensing
- Weight** . . . . . Appr. 1.26 lbs with Bus Terminal Cover; Appr. 1.45 lbs with Fixed Connection
- Materials** . . . . . Shaft: Stainless Steel; Flange: Aluminum, Housing: Die-Cast Zinc, Cable: PVC
- Starting Torque w/o Shaft sealing (IP 65)** . . 1.42 oz.in.(<0.01Nm)
- Starting Torque w/Shaft sealing (IP 67)** . . . 4.24 oz.in.(<0.03Nm)

<sup>1)</sup> Cable versions: -30° to +75°C (-22° to 167°F).

**General Electrical Characteristics:**

- Supply Voltage** . . . . . 10-30 VDC
- Current Consumption (w/o Output Load)** . Max. 65mA, 24 VDC
- Reverse Polarity**
- Protection at Power Supply** . . . . . Yes

Conforms to CE Requirements Acc. to EN 61000-6-1, EN61000-6-4 and EN 61000-6-3

**Interface Characteristics CANopen/CANlift:**

- Singleturn Resolution (Max., Scaleable)** . . 1-65536 (16 Bits), Default Scale Value is Set to 8192 (13 Bits)
- Number of Revolutions** . . . . . 4096 (12 Bits), (Scaleable 1-4096)
- Code** . . . . . Binary
- Interface** . . . . . CAN High-Speed According ISO 11898, Basic - and Full-CAN, CAN Specification 2.0 B
- Protocol** . . . . . CANopen profile DS 406 V3.1 with Manufacturer-Specific Add-On's

**General Information About CANopen:**

The CANopen encoders of the 5888 series support the latest CANopen communication profile according to DS 301 V4.02. In addition, device-specific profiles like the encoder profile DS 406 V3.1 and the profile DS 417 V1.1 (for lift applications) are available. The following operating modes may be selected: Polled Mode, Cyclic Mode, Sync Mode and a High Resolution Sync Protocol. Additionally, scale factors, preset values, limit switch values and many other parameters can be programmed via the CANBus. When switching the device on, all parameters, which have been saved on an EEPROM to protect them against power failure, are reloaded. The following output values may be combined by PDO mapping: position, speed, acceleration, and status.

5888 CANopen/CANlift

### CANopen Communication Profile V4.02:

Among others, the following functionality is integrated:

Class C2 Functionality

- NMT slave
- Heartbeat protocol
- High resolution sync protocol identity object
- Error behavior object
- Variable PDO mapping self-start programmable (power on to operational), 3 sending PDO's
- 1 Receiving PDO for synchronous preset operation with minimal jitter
- Knot address, baud rate and CANbus
- Programmable termination

### CANopen Lift Profile DS 417 V1.1:

The following parameters can be programmed:

- Car position unit
- 2 virtual devices
- 1 virtual device delivers the position in absolute measuring steps (steps)
- 1 virtual device delivers the position in absolute travel information in mm
- Lift number programmable
- Independent setting of the knot address in relation with the CAN identifier
- Factor for speed calculation (e.g. measuring wheel periphery)
- Integration time for speed value of 1-32
- 2 work areas with 2 upper and lower limits and the corresponding output states
- Variable PDO mapping for position, speed, acceleration, work area, status
- Extended failure management for position sensing with integrated temperature control
- User interface with visual display of bus and failure status - 3 LED's

**Note:**

All profiles stated here: Key-features.

The object 6003h "Preset" is assigned to an integrated key, accessible from the outside "Watchdog-controlled" device.

### SET Control Button (Zero or Defined Value, Option):

Protected against accidental activation, can only be pushed in with the tip of a ballpoint pen or similar.

### Diagnostic LED (Yellow):

**LED on at** . . . . . Optical sensor path faulty (code error, LED error), low voltage and overtemperature or CANlift profile DS 417 V1.1

### Protocol:

**Baud Rate** . . . . . 10-1000 kbits/s (Set by DIP Switches/Software Configurable)

**Node Address** . . . . . 1-127 (Set by Rotary Switches/Software Configurable)

**Termination Switchable** . . . . . Set by DIP Switches, Software Configurable

Price conscience encoders are available with optional connectors or cable connections in place of the costlier removable terminal box versions. Additionally, these encoders do not have user accessible DIP switches and require the user to program the address and baud rate through the software.

The models with the terminal cover include an integrated T-shaped coupler with the bus and power connections utilizing simple M12 connectors. The device address is set with two rotary switches while a bank of DIP switches set the baud rate and also allows the connection of a termination resistor.

Finally, all versions include three LED's located on the rear of the housing to indicate the status of the CAN bus as well as the status of the internal diagnostics.

**Sendix® Absolute, Multiturn Hub Shaft Type T8.5888 Specifications** **CANopen/CANlift**

**Pinouts** Notes 1), 2), 3)

A Male Encoder View	B Female Encoder View	C Male Encoder View
CCW		
<b>Bus In and Out M23</b>	<b>Bus Out M12 Pinout</b>	<b>Bus In M12 Pinout</b>
<b>Mating Cordset</b>	<b>Mating Cordset</b>	<b>Mating Cordset</b>
Consult Factory	RSC 572-*M	RKC 572-*M

- 1) See cable section for additional options.
- 2) "S" denotes shield tied to coupling nut.
- 3) \* = length in meters, available in 0.1 meter increments  $\geq 0.2$  meters.

**Standard Wiring / Pin Configuration**

**Bus Terminal Cover with Terminal Box**

(Connection 1)

Direction	OUT					IN				
Signal:	CAN Ground	CAN_Low (-)	CAN_High (+)	0 VOLT Power Supply	+VOLT Power Supply	0 VOLT Power Supply	+VOLT Power Supply	CAN_Low (-)	CAN_High (+)	CAN Ground
Abbreviation:	CG	CL	CH	0 V	+V	0 V	+V	CL	CH	CG

**Cable Connection**

(Connection A)

Direction	IN				
Signal:	0 VOLT Power Supply	+VOLT Power Supply	CAN_Low (-)	CAN_High (+)	CAN Ground
Abbreviation:	0 V	+V	CL	CH	CG
Cable Color	BK	RD	BL	WH	GY

**M23 Connector, M12 Connector or D-Sub 9**

(Connection I) (Connection E) (Connection K)

Direction	IN					Pinout
Signal:	0 VOLT Power Supply	+VOLT Power Supply	CAN_Low (-)	CAN_High (+)	CAN Ground	
Abbreviation:	0 V	+V	CL	CH	CG	
M23 PIN Assignment:	10	12	2	7	3	A
M12 PIN Assignment:	3	2	5	4	1	C
D-Sub 9	6	9	2	7	3	-

**Bus Terminal Cover with 2 - M12, 2 - M12, 2 - M23**

(Connection 2) (Connection F) (Connection J)

Direction	OUT					Pinout	IN					Pinout
Signal:	CAN Ground	CAN_Low (-)	CAN_High (+)	0 VOLT Power Supply	+VOLT Power Supply		0 VOLT Power Supply	+VOLT Power Supply	CAN_Low (-)	CAN_High (+)	CAN Ground	
Abbreviation:	CG	CL	CH	0 V	+V		0 V	+V	CL	CH	CG	
M23 PIN Assignment:	3	2	7	10	12	A	10	12	2	7	3	A
M12 PIN Assignment:	1	5	4	3	2	B	3	2	5	4	1	C

5888 CANopen/CANlift

**T8.5888 Flanges 5 & 6  
Cable Connection 1**

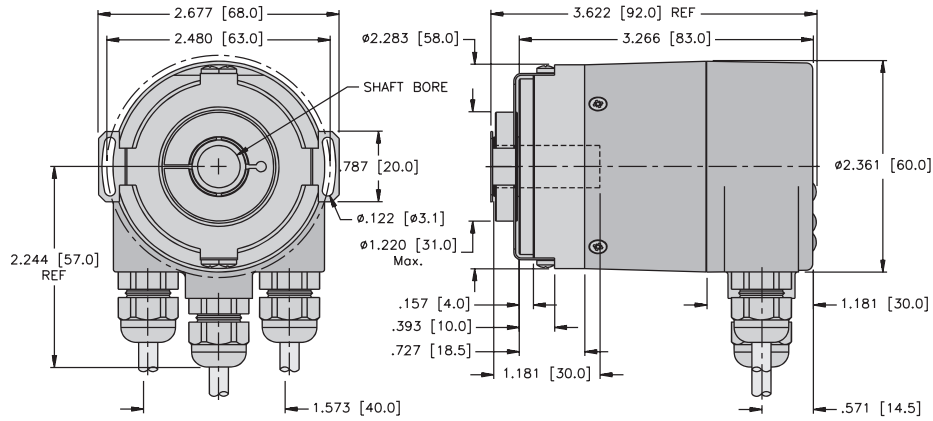

**T8.5888 Flanges 1 & 2  
M12 Connection 2**

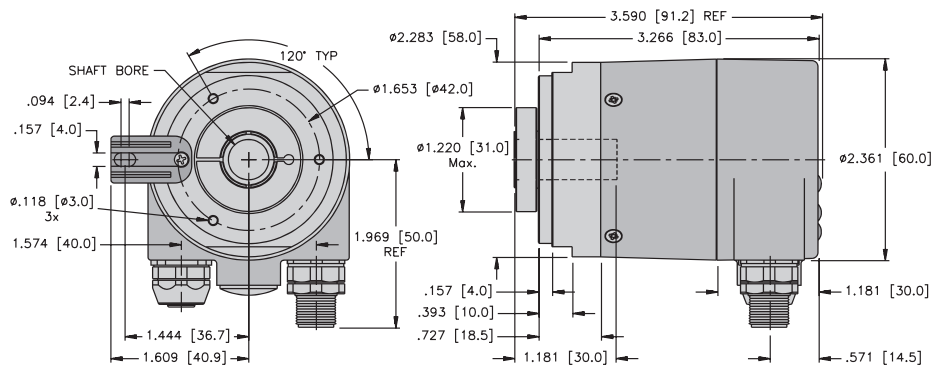

**T8.5888 Flanges 3 & 4  
M12 Connection 2**

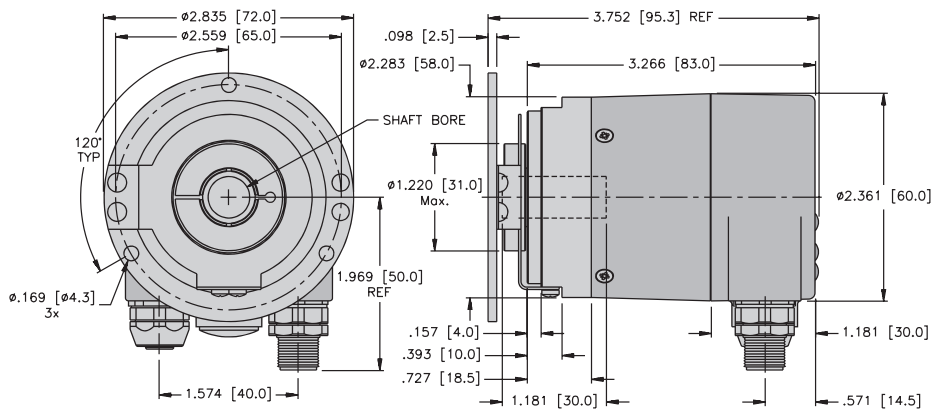

**Sendix® Absolute, Multiturn Hub Shaft Type T8.5888 Dimensions** **CANopen/CANlift**

**T8.5888 Flanges 3 & 4  
Cable Connection A**

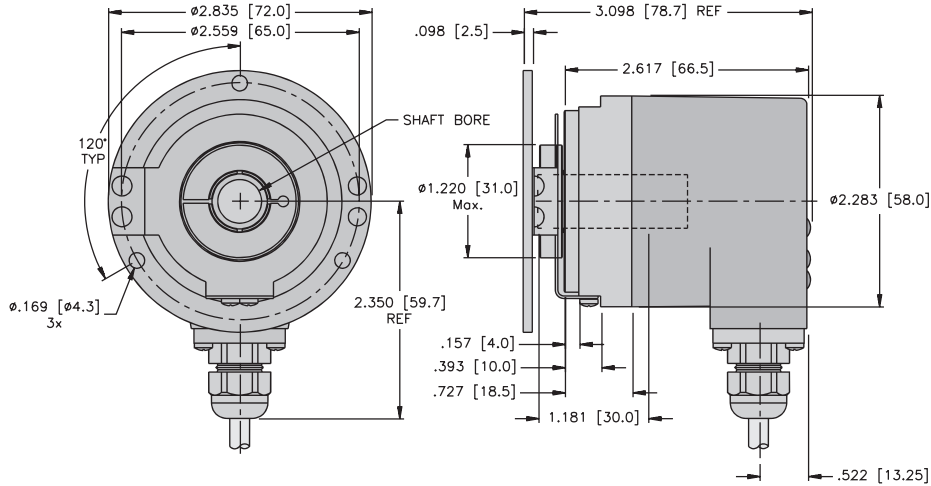

**T8.5888 Flanges 5 & 6  
M12 Connection E**

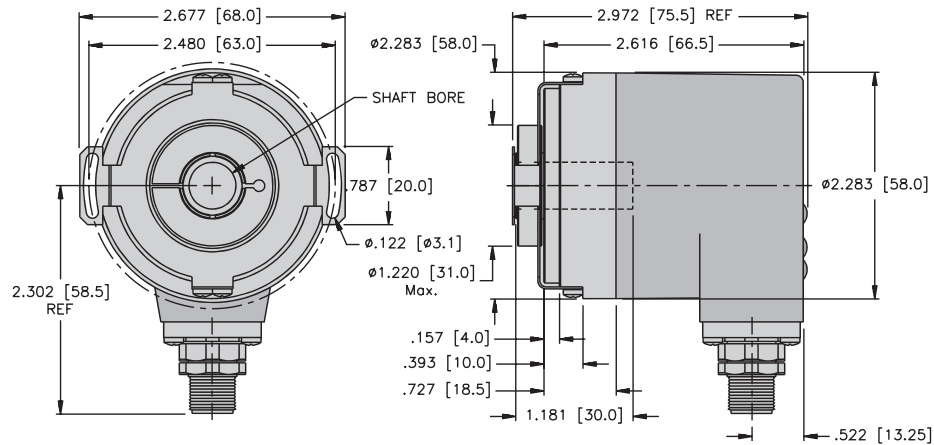

**T8.5888 Flanges 1 & 2  
M12 Connection F**

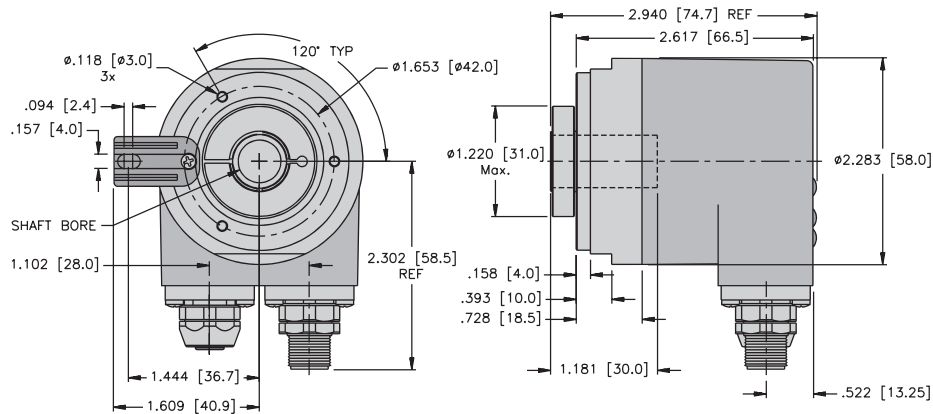

5888 CANopen/CANlift

**T8.5888 Flanges 1 & 2  
M23 Connection I**

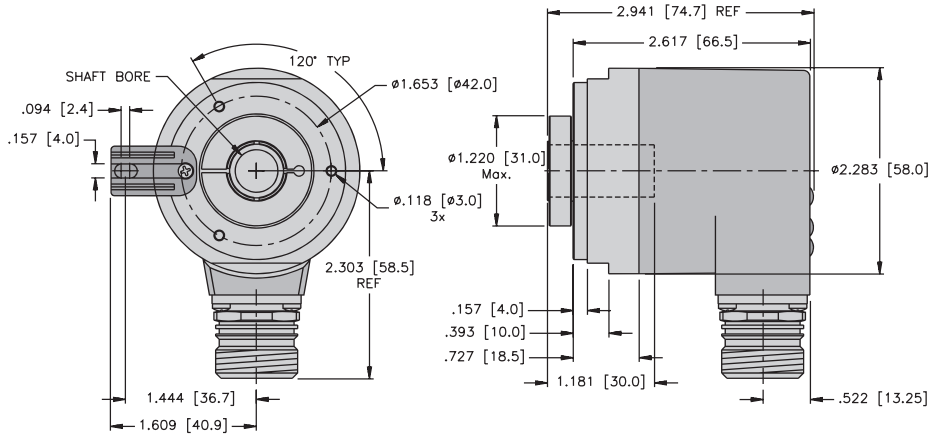

**T8.5888 Flanges 3 & 4  
M23 Connection J**

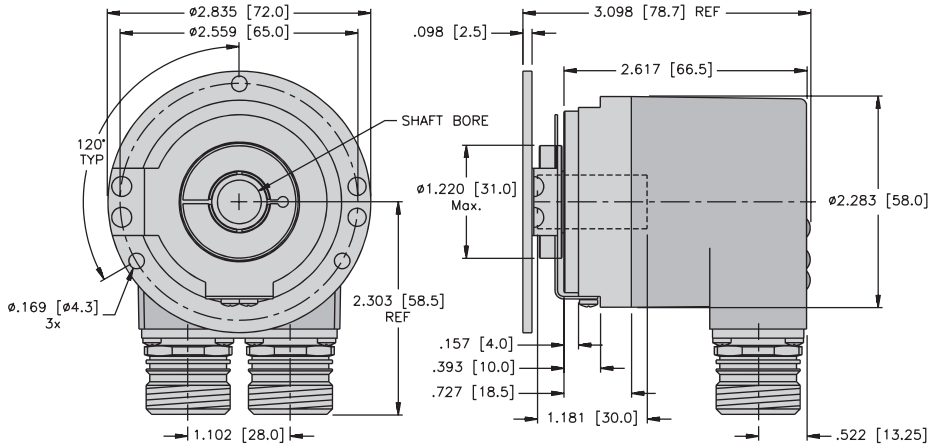

**T8.5888 Flanges 1 & 2  
D-Sub Connection K**

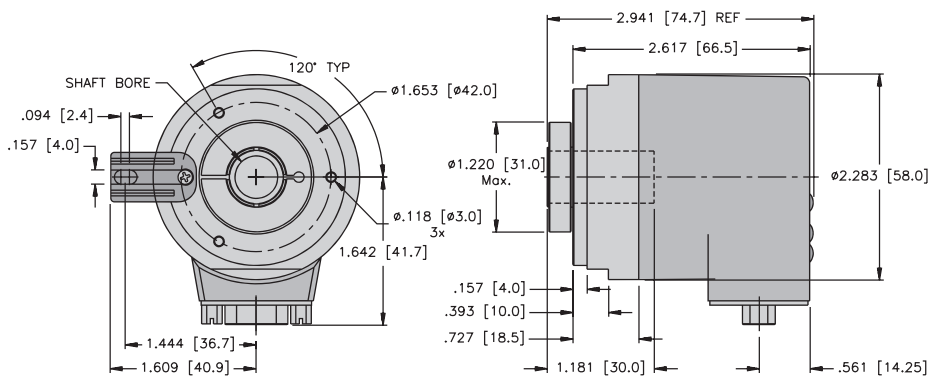



**Sendix<sup>®</sup> Absolute, Multiturn Hub Shaft Type T8.5888 PROFIBUS<sup>®</sup>-DP**

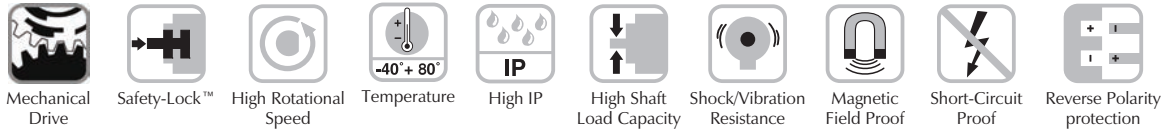

**T8. 5888. X X X X. XX1X.**

**Flange**

- 1 = Flange with torque stop IP 65
- 2 = Flange with torque stop IP 67
- 3 = Flange with stator coupling pitch circle Ø 65, IP 65
- 4 = Flange with stator coupling pitch circle Ø 65, IP 67
- 5 = Flange with stator coupling pitch circle Ø 63, IP 65
- 6 = Flange with stator coupling pitch circle Ø 63, IP 67

**Blind Hub Shaft**

- 3 = Ø10 mm
- 4 = Ø12 mm
- 5 = Ø14 mm
- 6 = Ø15 mm
- 8 = Ø9.52 mm [3/8"]
- 9 = Ø12.7 mm [1/2"]

**Input / Output Circuit**

- 3 = 10-30 VDC PROFIBUS-DP V0 Encoder Profile V1.1

**Options**

- 2 = No option
- 3 = Set button

**Fieldbus Profile**

- 31 = PROFIBUS-DP-V0 Encoder profile class 2

**Connection Type**

- 1 = Removable bus terminal cover, with radial screwed cable passage
- 2 = Removable bus terminal cover with 3 - M12 **eurofast**<sup>®</sup> connectors

**Features / Benefits**

- Captive bearings
- Wide temperature range
- Removable terminal box with M12 connector and cable versions
- Heavy duty diecast cover
- Compact size
- High speed integrated OptoASIC
- High IP rating

5888 PROFIBUS<sup>®</sup>-DP

## Mechanical:

Max. Speed w/o Shaft sealing (IP 65)	. . . . . 9000 RPM (Peak), 7000 RPM (Continuous) (up to 70°C)
Max. Speed w/o Shaft sealing (IP 65)	. . . . . 7000 RPM (Peak), 4000 RPM (Continuous) (up to Tmax)
Max. Speed w/Shaft sealing (IP 67)	. . . . . 8000 RPM (Peak), 6000 RPM (Continuous) (up to 70°C)
Max. Speed w/Shaft sealing (IP 67)	. . . . . 6000 RPM (Peak), 3000 RPM (Continuous) (up to Tmax)
Protection Rating	. . . . . IP 65 (IP 67 with Shaft Seal)
Operating Temperature <sup>1)</sup>	. . . . . -40° to +80°C (-40° to +176°F)
Shock Resistance	. . . . . Up to 250g
Vibration Resistance	. . . . . Up to 100g, 55-2000 Hz
Humidity	. . . . . 98% Relative, Non-Condensing
Weight	. . . . . Appr. 1.26 lbs with Bus Terminal Cover; Appr. 1.45 lbs with Fixed Connection
Materials	. . . . . Shaft: Stainless Steel; Flange: Aluminum, Housing: Die-Cast Zinc, Cable: PVC
Starting Torque w/o Shaft sealing (IP 65)	. . . . . 1.42 oz.in.(<0.01Nm)
Starting Torque w/Shaft sealing (IP 67)	. . . . . 4.24 oz.in.(<0.03Nm)

<sup>1)</sup> Cable versions: -30° to +75°C (-22° to 167°F).

## General Electrical Characteristics:

Supply Voltage	. . . . . 10-30 VDC
Current Consumption (w/o Output Load)	. . . . . Max. 65mA, 24 VDC
Reverse Polarity	
Protection at Power Supply	. . . . . Yes

Conforms to CE Requirements Acc. to EN 61000-6-1, EN61000-6-4 and EN 61000-6-3

## Interface Characteristics PROFIBUS-DP:

Singleturn Resolution (Max., Scaleable)	. . . . . 1-65536 (16 Bits), Default Scale Value is Set to 8192 (13 Bits)
Number of Revolutions	. . . . . 4096 (12 Bits), (Scaleable 1-4096)
Code	. . . . . Binary
Interface	. . . . . Specifications According to PROFIBUS-DP 2.0 Standard RS-485 Driver Galvanically Isolated
Protocol	. . . . . PROFIBUS Encoder Profile V1.1 Class 1 and Class 2 with Manufacturer-specific Enhancements

## PROFIBUS Encoder-Profile V11

The PROFIBUS-DP device profile describes the functionality of the communication and the user-specific component within the PROFIBUS field bus system. For encoders, the encoder profile is definitive. Here the individual objects are defined independent of the manufacturer. Furthermore, the profiles offer space for additional manufacturer-specific functions; this means that PROFIBUS-compliant device systems can be used now with the guarantee that they are ready for the future too.

**Sendix® Absolute, Multiturn Hub Shaft Type T8.5888 Specifications** **PROFIBUS® -DP**

**The Following Parameters Can Be Programmed:**

- Direction of rotation
- Scaling
- Number of steps per revolution
- Number of revolutions
- Total revolution over Singleturn/Multiturn
- Preset value
- Diagnostics mode

**SET Control Button (Zero or Defined Value, Option):**

Protected against accidental activation, can only be pushed in with the tip of a ballpoint pen or similar.

**Diagnostic LED (yellow):**

**LED on at** . . . . . Optical sensor path faulty (code error, LED error), low voltage and overtemperature

**Protocol**

- Baud Rate** . . . . . 12 Mbits/s
- Node Address** . . . . . 1-127 (Set by Rotary Switches)
- Termination Switchable** . . . . . Set by DIP Switches, Software Configurable

**The Following Functionality Is Integrated:**

- Galvanic isolation of the bus stage with DC/DC converter
- Line driver acc. to RS 485 max. 12 MB
- Address programmable via DIP switches
- Diagnostics LED
- Full class 1 and class 2 functionality

5888 PROFIBUS® -DP

Standard Wiring / Pin Configuration

Terminal Assignment with Terminal Box

(Connection 1)

Signal:	BUS IN				BUS OUT			
	B	A	0 V	+V	0 V	+V	B	A
Pin:	1	2	3	4	5	6	7	8

Terminal Assignment M12 - 3 Connector Version

(Connection 2)

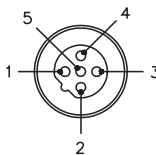
	Signal:	-	BUS-A	-	BUS-B	Shield	Male Pinout	Mating Cordsets <sup>2), 3), 4)</sup>
Bus In	Pin:	1	2	3	4	5		RKSW-455-*M

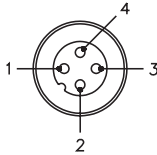
	Signal:	U <sub>B</sub>	-	0 V	-	Male Pinout	Mating Cordsets <sup>2), 4)</sup>
Power Supply	Pin:	1	2	3	4		RK 4.4T-*

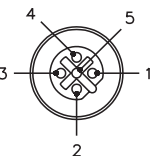
	Signal:	BUS-VDC <sup>1)</sup>	BUS-A	BUS_GND <sup>1)</sup>	BUS-B	Shield	Female Pinout	Mating Cordsets <sup>2), 3), 4)</sup>
Bus Out	Pin:	1	2	3	4	5		RSSW-455-*M

<sup>1)</sup> For powering an external PROFIBUS-DP terminating resistor.  
<sup>2)</sup> See cable section for additional options.  
<sup>3)</sup> "S" denotes shield tied to coupling nut.  
<sup>4)</sup> \* = length in meters, available in 0.1 meters increments  $\geq 0.2$  meters.

**Sendix® Absolute, Multiturn Hub Shaft Type T8.5888 Dimensions PROFIBUS® -DP**

**T8.5888 Flanges 5 & 6  
Cable Connection 1**

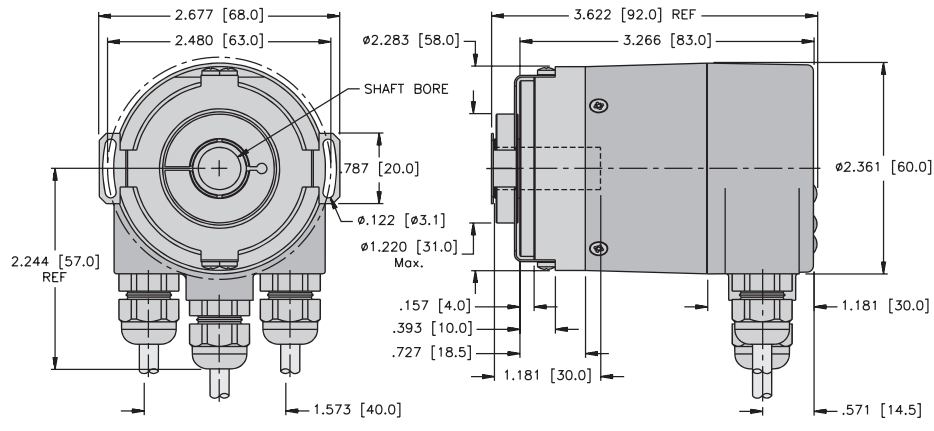

**T8.5888 Flanges 1 & 2  
M12 Connection 2**

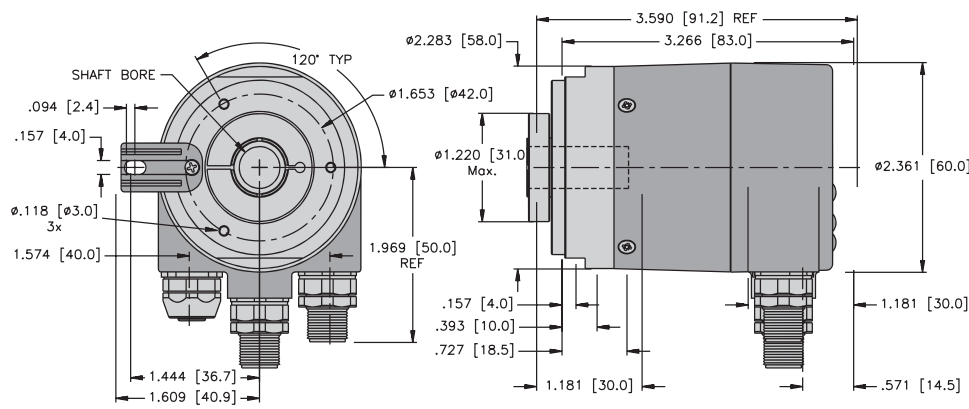

**T8.5888 Flanges 3 & 4  
M12 Connection 2**

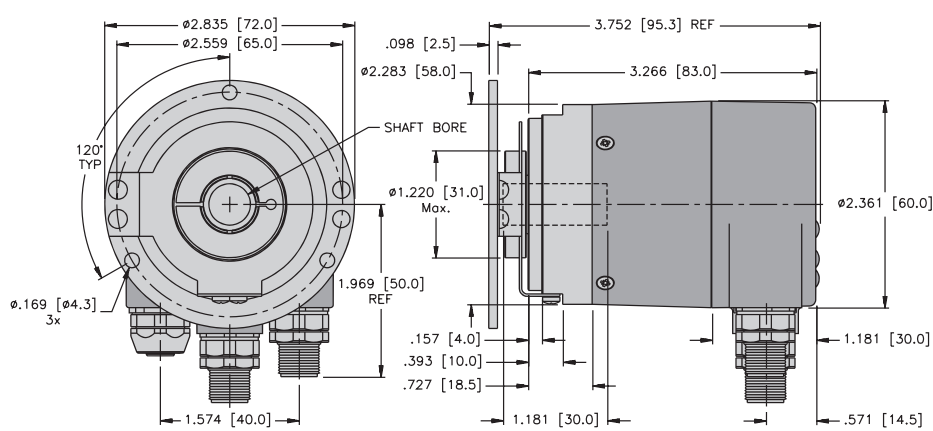

5888 PROFIBUS® -DP

# Kübler by TURCK

## Industrial Connectivity Products

### 12-Pin M23 *multifast*® Absolute Encoder Cordsets - SSI/BiSS, Analog, Sine Wave

- Female Coupling Nut, Female Contact
- Shielded High Grade Oil and UV Resistant PVC
- Shield Not Tied to Coupling Nuts <sup>1)</sup>



Housing Style	Part Number	Specifications	Application	Pinouts
	E-CK 12-6901-*/A <sup>2)</sup>	12x26 Grey PVC 7.3 mm O.D. 26 AWG Braided Shield 80°C	12-pin Absolute	

\* Reversed.

<sup>1)</sup> Add "S" to the part number to connect shield to the coupling nut. Ex. E-CKM 12-1687-\*/A.

<sup>2)</sup> E-CK 12-pin encoder cables incorporate reversed direction pinouts from the standard *multifast* 12-pin connectors.

### 12-Pin M23 *multifast*® Field Wireable Encoder Connectors, Shielded, Solder Cup

- 12-pin
- Female Coupling Nut, Female Contact Holders



Housing Style	Part Number	Specifications	Application	Pinouts
	E-CKS 12-0 <sup>1)</sup>	Solder Cup up to 18 AWG	Metal, fully shielded Mates with 12-pin encoders	

\* Reversed.

<sup>1)</sup> E-CK 12-pin encoder cables incorporate reversed direction pinouts from the standard *multifast* 12-pin connectors.

**euofast® Encoder Cordsets Selection Matrix PROFIBUS®-DP**

		euofast				
		Pin (Male)		Socket (Female)		
		1  RSSW	3  WSSW	2  RKSW	4  WKSX	
Bare		RSSW 455-*M	WSSW 455-*M	RKSW 455-*M	WKSX 455-*M	
euofast	Pin (Male)	1  RSSW	RSSW RSSW 455-*M	RSSW WSSW 455-*M	RSSW RKSW 455-*M	RSSW WKSX 455-*M
		3  WSSW		WSSW WSSW 455-*M	WSSW RKSW 455-*M	WSSW WKSX 455-*M
	Socket (Female)	2  RKSW			RKSW RKSW 455-*M	RKSW WKSX 455-*M
		4  WKSX				WKSX WKSX 455-*M

\* Indicates length in meters.  
 Refer to the Cordsets Builder at [www.turck.com](http://www.turck.com) for assistance with cordset/cable combinations.  
 Standard cable lengths are 1, 2, 4, 5, 6, 8, 10, 15, and in +5 meter increments from there. Consult factory for other lengths.  
 For stainless steel coupling nuts change part number RSSW...RSSWV.  
 Additional cable types available in the Fieldbus and Network I/O Catalog.

**Pinouts**

euofast	455 Series Pinout	euofast
<p><b>Male</b></p>	<p>1. NC                  2. Green (TxD)                  3. NC                  4. Red (RxD)                  5. Bare (Shield Drain Wire)</p>	<p><b>Female</b></p>

# Kübler by TURCK Industrial Connectivity Products

## 4-Wire M12 eurofast® Cordsets, Standard Plug Body

- Straight Female Connector
- NEMA 1, 3, 4, 6P and IEC IP 68 Protection
- 250 VAC/300 VDC, 4 A



Housing Style	Part Number	Cable	Features	Pinouts
	RK 4.41T-*	AWM PVC NAMUR Blue 4x22 AWG 105°C 5.2 mm OD Cable #RF50598-*M <sup>†</sup>	<i>flexlife</i>	
	RK 4.41T-*/S529	AWM PUR/Heavy Braid Double Jacket Yellow 4x20 AWG 105°C 5.8 mm OD Cable #RF50526-*M <sup>†</sup>	<i>Cut/Abrasion Immune Braided Mechanical Shield</i>	
	RK 4.43T-*	AWM PVC Yellow 4x22 AWG 105°C 5.2 mm OD Cable #RF50530-*M <sup>†</sup>	<i>flexlife</i>	
	RK 4.43T-*/S90	AWM PUR Yellow 4x22 AWG 105°C 5.2 mm OD Cable #RF50613-*M <sup>†</sup>	<i>Cut/Abrasion Immune</i>	
	RK 4.4T-*	AWM PVC Grey 4x22 AWG 105°C 5.2 mm OD Cable #RF50516-*M <sup>†</sup>	<i>flexlife</i>	
	RK 4.4T-*/S90	AWM PUR Grey 4x22 AWG 105°C, 5.2 mm OD Cable #RF50532-*M <sup>†</sup>	<i>Cut/Abrasion Immune</i>	
	RK 4.4T-*/S101	AWM TPE Grey 4x22 AWG 105°C, 5.7 mm OD Cable #RF50941-*M <sup>†</sup>	<i>flexLife-10, High Flex Over 10 Million Cycles</i>	
	RK 4.4T-*/S824	PLTC PVC Grey 4x22 AWG 105°C, 5.2 mm OD Cable #RF50698-*M <sup>†</sup>	<i>Tray Rated</i>	
	RK 4.4T-*/S618	AWM PVC Grey 4x22 AWG, Foil/Drain 105°C, 5.2 mm OD Cable #RF50577-*M <sup>†</sup>	<i>RFI/EMI Shielding</i>	
RK 4.4T-*/S618/S824	PLTC PVC Grey 4x22 AWG, Foil/Drain 105°C, 5.2 mm OD Cable #RF50773-*M <sup>†</sup>	<i>RFI/EMI Shielding Tray Rated</i>		

\* Length in meters. Standard cable lengths are 2, 4, 6, 8 and 10 meters. Consult factory for other lengths.  
 \*\* Standard coupling nut material is nickel plated brass "RK .."; "RKK .." indicates nylon and "RKV .." indicates 316 stainless steel.  
 † For reelfast® cable information see Connectivity Catalog.



**8-Wire M12 euofast® Encoder Field Wireable Connectors, Shielded, Screw Terminals**

- Screw Terminals
- No Soldering Required
- IEC IP 67 Protection



Housing Style	Part Number	Specifications	Application	Pinouts
<p>Female</p>	CMB 8181-0	<p>Nickel Plated Brass PG9 cable gland accepts 6-8 mm cable diameter Screw terminal accepts up to 18 AWG conductors 85°C 60 VAC/75 VDC, 4 A</p>	<p>Metal, Fully Shielded Mates with standard key 8-pin cordsets and receptacles</p>	<p>CW*</p>
<p>Male</p>	CMBS 8181-0		<p>Metal, Fully Shielded Mates with standard key 8-pin cordsets and receptacles</p>	

Cordsets

# Kübler by TURCK Industrial Connectivity Products

## 8-Pin M12 eurofast®, Encoder Cordsets

- For use with Kübler by TURCK's SSI Encoders
- Straight and Right Angle Female Connectors
- NEMA 1, 3, 4, 6P, and IEC IP 68
- 60 VAC/75 VDC, 2 A



Housing Style	Part Number	Cable	Features	Pinouts
<p><b>E-RKC ..</b></p>	E-RKC 8T-264-* <sup>1)</sup>	AWM PVC Black 8x24 AWG, 4 STP 105°C 7.3 mm OD RF51264-*M+	SSI, Differential Mode Applications, RFI/EMI Protection	1. WH 2. BN 3. GN 4. YE 5. GY 6. PK 7. BU 8. RD
<p><b>E-WKC ..</b></p>	E-WKC 8T-264-* <sup>1)</sup>			

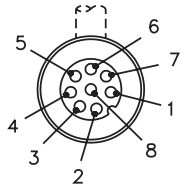

\* Length in meters. Standard cable lengths are 2, 5, 10 and 15 meters. Consult factory for other lengths.  
 \*\* Standard coupling nut material is nickel plated brass "E-RKC../E-WKC.."; "E-RKCV../E-WKCV.." indicates 316 stainless steel.  
 + For **reelfast**® cable information see Connectivity Catalog.  
 STP = Shielded twisted pair.  
<sup>1)</sup> Change RKC/WKC to RKS/WKS to tie the shield to the coupling nut.



## Call TURCK for All Your Encoder Needs 1-800-544-7769

**TURCK Inc.** sells its products through Authorized Distributors. These distributors provide our customers with technical support, service and local stock. **TURCK** distributors are located nationwide - including all major metropolitan marketing areas.

For Application Assistance or for the location of your nearest **TURCK** distributor, call:

1-800-544-7769

Specifications in this manual are subject to change without notice. **TURCK** also reserves the right to make modifications and makes no guarantee of the accuracy of the information contained herein.

Literature and Media questions or concerns?  
Contact Marketing Communications **TURCK** USA - [media@turck.com](mailto:media@turck.com)



### **USA**

TURCK Inc.  
3000 Campus Drive  
Minneapolis, MN 55441  
Phone: (763) 553-7300  
Fax: (763) 553-0708  
Application Support:  
1-800-544-7769



### **MEXICO**

TURCK MEXICO S. DE R.L. DE C.V.  
Carr. Saltillo-Zacatecas km 4.5 s/n  
Parque Industrial "La Angostura"  
Saltillo, COAH. C.P. 25070  
Mexico  
Phone: +52 (844) 411-6647/46  
Fax: +52 (844) 482-6926  
Local Toll Free: 01-800-01-88725  
E-mail: ventasmexico@turck.com



### **CANADA**

CHARTWELL ELECTRONICS, INC.  
140 Duffield Drive  
Markham, Ontario  
Canada, L6G 1B5  
Phone: (905) 513-7100  
Fax: (905) 513-7101  
Toll Free: 1-877-513-7769



### **GERMANY**

**WORLD HEADQUARTERS**  
Hans TURCK GmbH & Co. KG  
Witzlebenstrasse 7  
D-45472 Muelheim an der Ruhr  
Federal Republic of Germany  
Phone: (+49) 208-49 52-0  
Fax: (+49) 208-49 52 264



### **AUSTRALIA**

TURCK Australia Pty. Ltd.  
Unit 5, 6-7 Gilda Court  
Mulgrave, Victoria 3170  
Australia  
Phone: (+61) 3 9560 9006  
Fax: (+61) 3 9560 1620  
Local Toll Free: 1300 132566  
E-mail: turckaustralia@turck.com

**www.turck.com**

**....Sense It!....Connect It!....Bus It!....Solve It!**