

TURCK
works

*smart
plug*

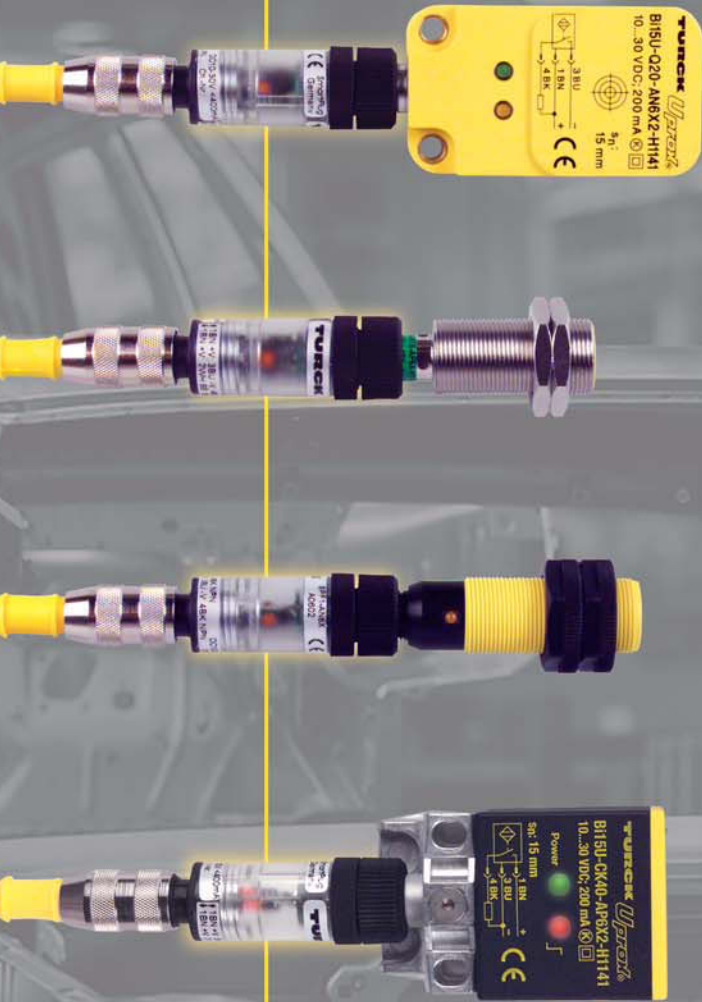

Add "Smarts" to
Your Sensor

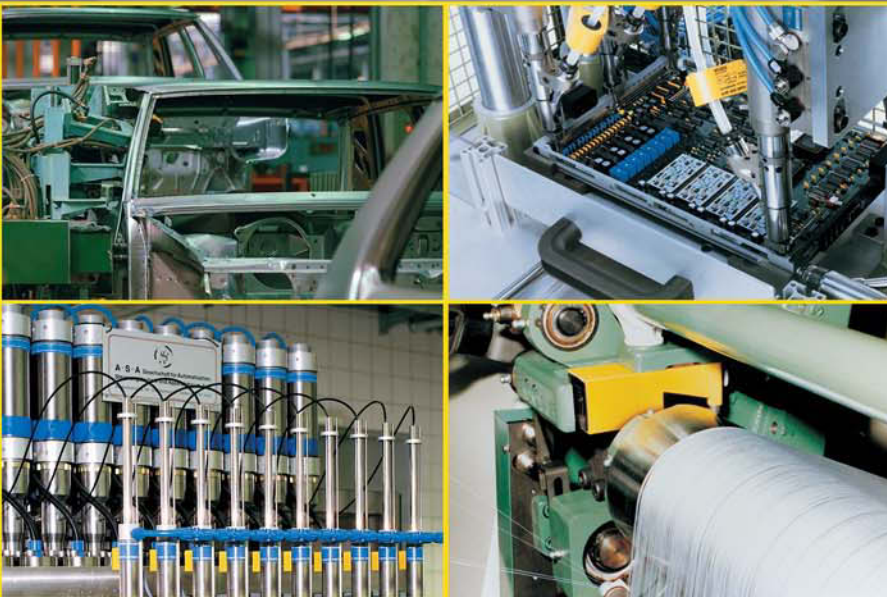

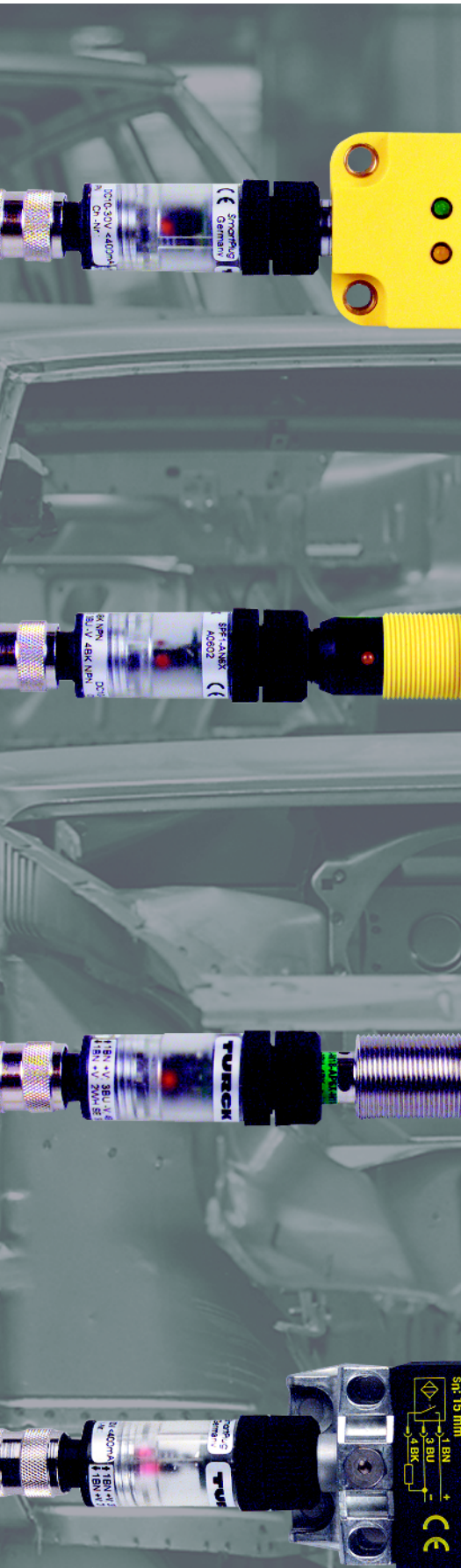

SmartPlug

Add “Smarts” to Your Sensor

SmartPlug makes your sensor or switch “Smart” by adding functionality to your signal output via a simple, teachable **Plug and Work** solution. Add functions such as timing, counting, speed monitoring or signal inversion by simply plugging the SmartPlug into your sensor or switch.

Programming is done via a simple “teach” input on the existing pin #2 of your existing M12x1 (**euofast**®) connector. The **SmartPlug** works with not only **TURCK** sensors, but with 3-wire DC sensors from many different manufacturers. For connection to sensors using M8x1 (**picofast**®), or 7/8-16UN (**minifast**®) connectors, adaptor cables are available.

SmartPlugs may be combined in series to provide multiple functions, such as a speed monitor with a time delay.

SmartPlug Features:

- Add function to existing installations.
- Solve control problems quickly in the field.
- Simple plug-in installation – uses industry standard M12x1 4-pin connectors (**euofast**).
- Programmed through “teach” input – Pin 2. LED aids programming.
- All styles are 400 mA short-circuit-proof, noise immune switching amplifiers.



Table of Contents

Part Number	Function	Page
SPC1-AP6X SPC1-AN6X	Pulse or interval counters	4 - 5
	<i>Also used for:</i>	
	- N.C./N.O. converter	
	- 400 mA switching amplifier	
SPF1-AP6X SPF1-AN6X	Over or under speed monitors	6 - 7
	<i>Also used for:</i>	
	- 400 mA switching amplifier	
SPN1-AP6-ARN6X SPN1-AN6-ARP6X	- PNP to NPN converter	8 - 9
	- NPN to PNP converter	
	<i>Also used for:</i>	
	- N.C./N.O. converter	
	- 400 mA switching amplifier	
SPT1-AP6X SPT1-AN6X	On-delay or off-delay timer	10 - 11
	<i>Also used for:</i>	
	- Pulse stretching	
	- 400 mA switching amplifier	
VB2-SP1	Molded pushbutton programmer	12
	with connectors	



SPC1-AP6X / SPC1-AN6X

Programmable pulse or interval counter

- Direct adaptation between sensor and connecting cable
- Counting of pulses or intervals
- Simple setting by external teach-input
- No additional wiring required
- Counting range from 0 to 65535
- Switching amplifier up to 400 mA
- N.C./N.O. inverter



The SPC1 SmartPlug is a freely programmable counter for the direct adaptation to sensors with a standardized M12x1 connection.

The SPC1 SmartPlug is available in 2 versions:

PNP input - PNP output SPC1-AP6X (for use with PNP sensors)

NPN input - NPN output SPC1-AN6X (for use with NPN sensors)

Connection:

The SmartPlug is very easy to connect; it is plugged onto the M12x1 connector of a sensor and the connecting cable is connected to the other side of the SmartPlug. The sensor configuration has to meet the standards (1 +V (BN) 3 -V (BU) 4 output (BK)).

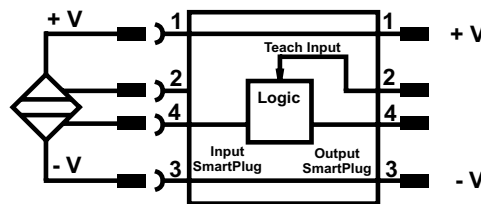

Setting:

The setting of the preset number is made by using the signals "teach input" and "input SmartPlug". If for example, 4 pulses have to be counted, the setting can be made as follows (operating voltage being switched on):

1. Connect teach input with +V.
2. Actuate the sensor 4 times (= 4 pulses) - The SmartPlug recognizes automatically 4 pulses at the "input SmartPlug".
3. Disconnect teach input from +V → READY.

After this setting, the output of the SmartPlug is activated every fourth pulse. The setting is maintained when the sensor is switched off.

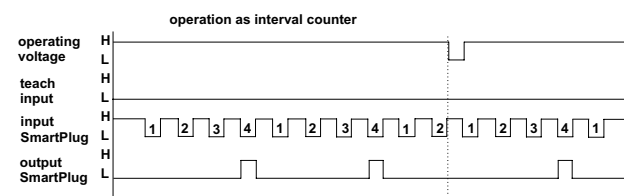
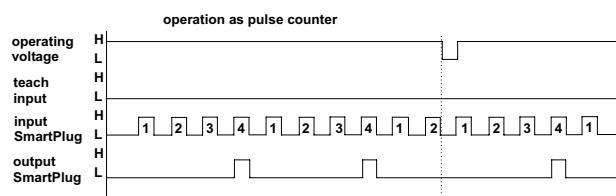
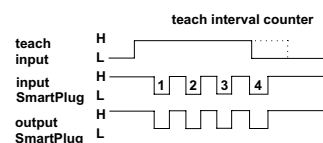
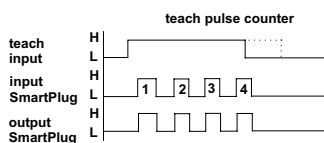

H = input or output active; L = input or output inactive

When switching on the operating voltage, the counting procedure is reset. The initial state of the preset number is 1 (pulse counter).

Technical Data

Operating Voltage	10-30 VDC, residual ripple of max. 10%	Display:	Red LED
Own Current Consumption:	<10 mA	Housing Material:	Plastic PBTP/PA
Input Resistance:	>10 kΩ	Protection Standard:	IP 67
Max. Input Frequency:	10 kHz	Dimensions Inches[mm]:	See diagram
Min. Response Time:	0.1 ms	Connection Input:	4-pin socket M12x1
Max. Output Current:	400 mA short-circuit proof	Connection Output:	4-pin connector M12x1
Ambient Temperature Range:	0° to +60°C (+32° to +140°F)	Weight:	15 g
Storage Temperature Range:	-20° to +60°C (-4° to +140°F)		

Preset to factory setting 1 pulse counter

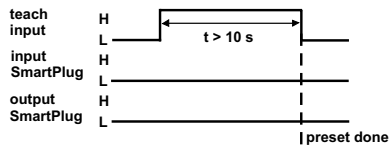

or

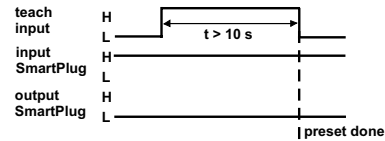

Wiring Diagrams

SPC1-AP6X

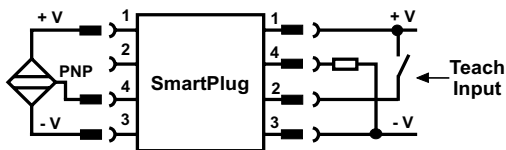

SPC1-AN6X

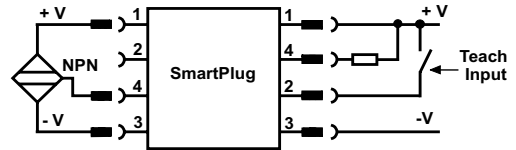

Application Examples:

- Gearwheel/Divider: On a gearwheel with 100 teeth, one pulse per rotation is to be measured.
 - A suitable sensor with standardized M12x1 connection is mounted in a way that each tooth is safely recognized.
 - A SmartPlug SPC1 is connected between sensor and sensor connecting cable.
 - The preset number 100 is taught into the SmartPlug, → connect "teach input" with +V, turn round the gearwheel exactly one time.
 - Disconnect "teach input" from +V. READY

At the output of the SmartPlug, one pulse per rotation is measured.
- Counting parts: Bulk material is filled into cartons by means of a conveyor belt. The task is to specify the exact number of parts required to fill up the carton.
 - A suitable sensor with standardized M12x1 connection is mounted in a way that all parts are safely recognized.
 - A SmartPlug SPC1 is connected between sensor and sensor connecting cable.
 - A "teach input" stays connected to +V until the desired number of parts has passed the sensor (=unit the carton is full).
 - Disconnect "teach input" from +V. READY

At the output of the SmartPlug, one pulse is measured when the preset quantity of parts has been recorded; the carton is full.
- Switching amplifier: Most sensors have a maximum output current of 100 mA to 200 mA. By using a SmartPlug, the maximum output current can be increased to 400 mA.
 - A SmartPlug SPC1 is connected between sensor and sensor connecting cable.
 - The "teach input" stays connected to +V until the sensor has been actuated once (preset number 1).
 - Disconnect "teach input" from +V. READY

At the output of the SmartPlug every input pulse is measured, the output can be charged with 400 mA.
- N.C./N.O. inverter: Teach the SmartPlug as interval counter "1". An input N.C. signal will be inverted into a N.O. signal and reverse.

SPF1-AP6X / SPF1-AN6X

Programmable over or under speed monitor

- Direct adaptation between sensor and connecting cable
- Teachable speed limit
- Simple setting by external teach-input
- No additional wiring required
- Frequency range 0.015 Hz - 1 kHz
- Output load up to 400 mA



The SPF1 SmartPlug is a frequency threshold module for the direct adaptation to sensors with a standard M12x1 connection.

The SPF1 SmartPlug is available in 2 versions:

PNP input - PNP output SPF1-AP6X (for use with PNP sensors)

NPN input - NPN output SPF1-AN6X (for use with NPN sensors)

Connection:

The SmartPlug is very easy to connect; it is plugged onto the M12x1 connector of a sensor and the connecting cable is connected to the other side of the SmartPlug. The sensor configuration has to meet the standards (1 +V (BN) 3 -V (BU) 4 output (BK)).

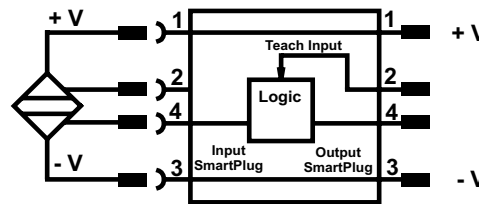

Function:

The SmartPlug SPF1 observes the frequency of the signal at the pin "input SmartPlug". The output is activated if the setup frequency falls below approximately 5%.

Setting for under speed monitoring:

1. Set sensor up to sense object with SmartPlug SPF1 connected. Make sure sensor is sensing properly and output is switching.
2. Move object or set rotation to nominal speed.
3. Connect +voltage +V to "Teach Input" and then disconnect (turn off) voltage +V.
(Pulse +V to Teach Input, >1 full cycle of senses object - e.g. >1 full revolution)
4. Done, if speed or frequency drops by 5% or 95% of nominal speed, then SmartPlug is activated.

Setting for over speed monitoring:

(Note: over speed output will be inverted. i.e. output activated for normal speed & output off for over speed.)

1. Set sensor up to sense object with SmartPlug SPF1 connected. Make sure sensor is sensing properly and output is switching.
2. Move object to set rotation to 106% plus X% over speed allowance of nominal speed.
3. Connect +voltage +V to "Teach Input" and then disconnect (turn off) voltage +V.
(Pulse +V to Teach Input, >1 full cycle of senses object - e.g. >1 full revolution).
4. Done. If speed or frequency goes above setpoint, then SmartPlug output goes off.

Technical Data

Operating Voltage:	10-30 VDC, residual ripple of max. 10%	Display:	Red LED
Own Current Consumption:	<10 mA	Housing Material:	Plastic PBTP/PA
Input Resistance:	>10 kΩ	Protection Standard:	IP 67
Max. Input Frequency:	10 kHz	Dimensions Inches[mm]:	See diagram
Min. Response Time:	0.1 ms	Connection Input:	4-pin socket M12x1
Max. Output Current:	400 mA short-circuit proof	Connection Output:	4-pin connector M12x1
Ambient Temperature Range:	0° to +60°C (+32° to +140°F)	Weight:	15 g
Storage Temperature Range:	-20° to +60°C (-4° to +140°F)		

SPF1-AP6X

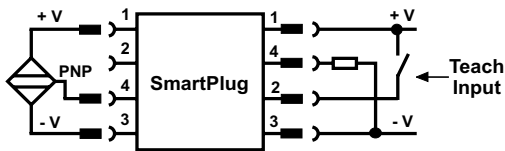

SPF1-AN6X

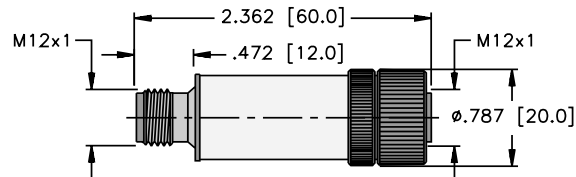
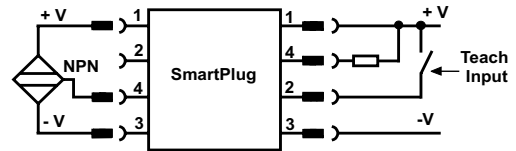

Applications Examples:

1. Jam detection
2. RPM Observation
3. Conveyor built back detection
4. Cooling fan motion control

SPN1-AP6-ARN6X / SPN1-AN6-ARP6X

PNP/NPN or NPN/PNP converter, adjustable N.O./N.C. inverter

- Direct adaptation between sensor and connecting cable
- N.C./N.O. function adjustable
- Simple setting via external teach-input
- No additional wiring required
- Switching frequency up to 10 kHz
- Switching amplifier up to 400 mA



The SPN1 SmartPlug is a switching channel converter for the direct adaptation to sensors with a standard M12x1 connection.

The SPN1 SmartPlug is available in 2 versions:

- PNP input - NPN output SPN1-AP6-ARN6X (for the conversion of PNP sensors to NPN output)
- NPN input - PNP output SPN1-AN6-ARP6X (for the conversion of NPN sensors to PNP output)

Connection:

The SmartPlug is very easy to connect: it is plugged onto the M12x1 connector of a sensor and the connecting cable is connected to the other side of the SmartPlug. The sensor configuration has to meet the standards (1 +V (BN) 3 -V (BU) 4 output (BK)).

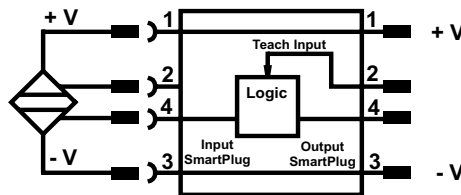

Function:

The SmartPlug SPN1-AP6-ARN6X converts a PNP input signal into a NPN output signal. The SmartPlug SPN1-AN6-ARP6X converts a NPN input signal into a PNP output signal. Additionally the signal can be inverted (N.C./N.O. function).

Setting:

The setting of the inverting function is made by means of the signals "teach input" and "input SmartPlug"

Example:

1. Setting the SmartPlug into the inverting mode:
 - a) activate sensor (output is on)
 - b) connect teach input and +V and disconnect (pulse or signal to +V). READY
2. Setting the SmartPlug into the non-inverting mode (factory setting)
 - a) inactivate Sensor (output is off)
 - b) connect teach input and +V and disconnect (pulse or signal to +V). READY

This setting is maintained when the sensor is off.

Technical Data

Operating Voltage: 10-30 VDC, residual ripple of max. 10%
Own Current Consumption: <10 mA
Input Resistance: >10 kΩ
Max. Input Frequency: 10 kHz
Min. Response Time: 0.1 ms
Max. Output Current: 400 mA short-circuit proof
Ambient Temperature Range: 0° to +60°C (+32° to +140°F)
Storage Temperature Range: -20° to +60°C (-4° to +140°F)

Display: Red LED
Housing Material: Plastic PBTP/PA
Protection Standard: IP 67
Dimensions Inches[mm]: See diagram
Connection Input: 4-pin socket M12x1
Connection Output: 4-pin connector M12x1
Weight: 15 g

H= input/output active
 L= input/output inactive

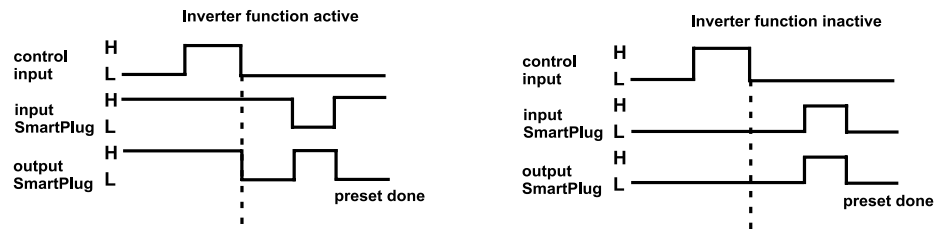

SPN1-AP6-ARN6X

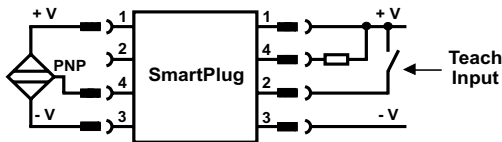

SPN1-AN6-ARP6X

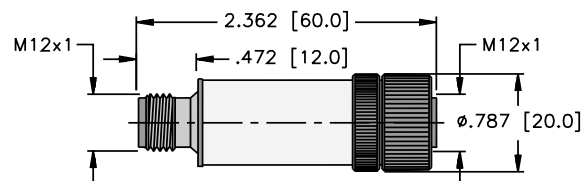
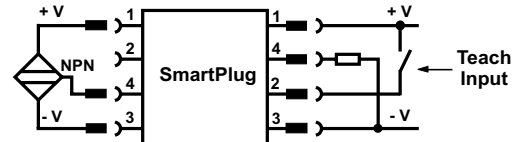

Function	SmartPlug	Setting
PNP / NPN converter	SPN1-AP6-ARN6X	Factory setting
NPN / PNP converter	SPN1-AN6-ARP6X	Factory setting
PNP / NPN converter and N.C. / N.O. inverter	SPN1-AP6-ARN6X	Setup: N.O. → N.C.
NPN / PNP converter and N.C. / N.O. inverter	SPN1-AN6-ARP6X	Setup: N.O. → N.C.

SPT1-AP6X / SPT1-AN6X

Programmable timer for on-delay time or off-delay time

- Direct adaptation between sensor and connecting cable
- Teachable as on-delay time or off-delay time
- Simple setting by external teach-input
- No additional wiring required
- Time range between 1 and 65535 ms
- Switching amplifier up to 400 mA
- Can be used as pulse stretcher



The SPT1 SmartPlug is a freely programmable timer for the direct adaptation to sensors with a standardized M12x1 connection.

The SPT1 SmartPlug is available in 2 versions:

- PNP input - PNP output SPT1-AP6X (for use with PNP sensors)
- NPN input - NPN output SPT1-AN6X (for use with NPN sensors)

Connection:

The SmartPlug is very easy to connect: it is plugged onto the M12x1 connector of a sensor and the connecting cable is connected to the other side of the SmartPlug. The sensor configuration has to meet the standards (1 +V (BN) 3 -V (BU) 4 output (BK)).

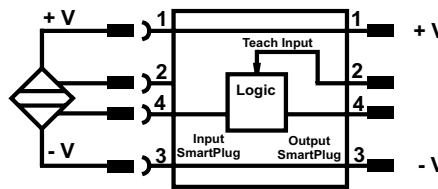

Setting:

The setting of the delay time is made by means of the signals "Teach input" and "Input SmartPlug". A delay time of 4 seconds for example can be set as follows (the operating voltage being switched on):

1. Connect teach input with +V
2. Actuate sensor for 4 seconds
3. Disconnect teach input from +V. READY

After this setting the SmartPlug has a slow operation lasting 4 seconds. This setting is maintained when the sensor is switched off.

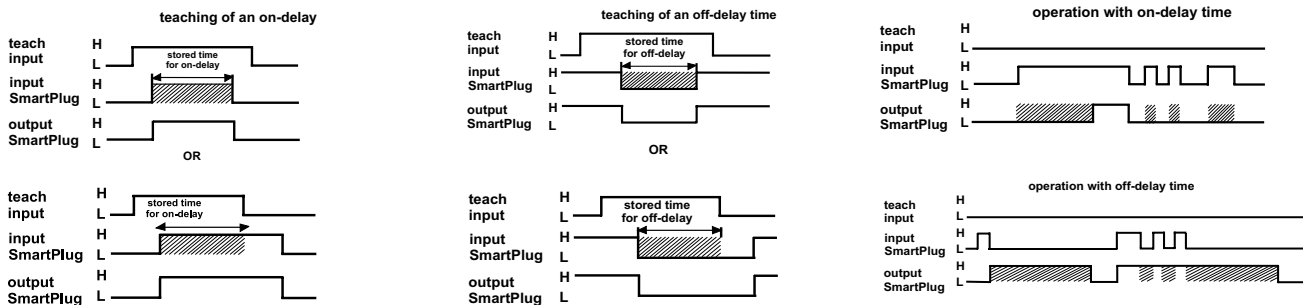

When switching on the operating voltage, the timer is reset. The initial state of the preset time is 100 ms off-delay.
 H= input/output active L= input/output inactive

Technical Data

Operating Voltage:	10-30 VDC, residual ripple of max. 10%	Display:	Red LED
Own Current Consumption:	<10 mA	Housing Material:	Plastic PBTP/PA
Input Resistance:	>10 kΩ	Protection Standard:	IP 67
Max. Input Frequency:	10 kHz	Dimensions Inches[mm]:	See diagram
Min. Response Time:	0.1 ms	Connection Input:	4-pin socket M12x1
Max. Output Current:	400 mA short-circuit proof	Connection Output:	4-pin connector M12x1
Ambient Temperature Range:	0° to +60°C (+32° to +140°F)	Weight:	15 g
Storage Temperature Range:	-20° to +60°C (-4° to +140°F)		

To preset to factory setting 100 ms off-delay

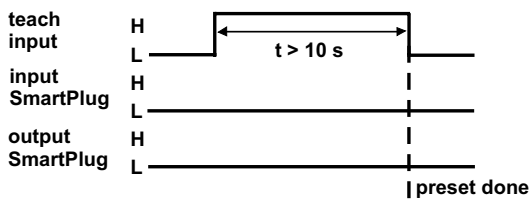

or

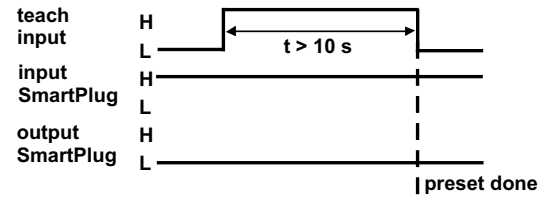

SPT1-AP6X

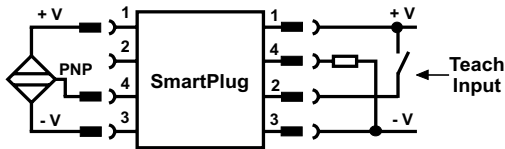

SPT1-AN6X

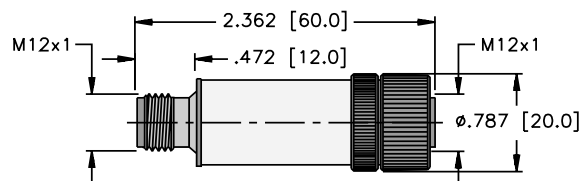
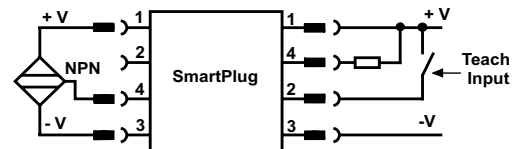

SmartPlug Programing Push Button

VB2-SP1



Dimensions

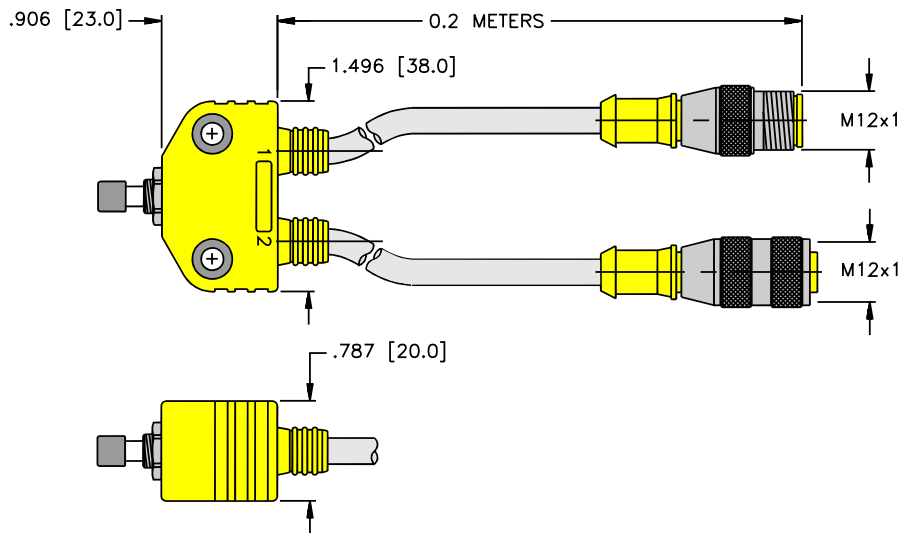

Pinouts

Female	Male
4-pin	4-pin

Wiring Diagram

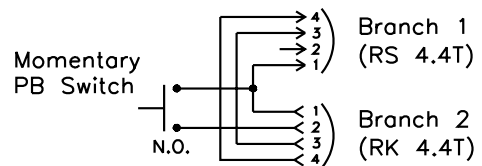

Notes:

TURCK Inc. sells its products through Authorized Distributors. These distributors provide our customers with technical support, service and local stock. **TURCK** distributors are located nationwide - including all major metropolitan marketing areas.

For Application Assistance or for the location of your nearest **TURCK** distributor, call:

1-800-544-PROX (1-800-544-7769)

Specifications in this manual are subject to change without notice. **TURCK** also reserves the right to make modifications and makes no guarantee of the accuracy of the information contained herein.

Literature and Media questions or concerns?

Contact Marketing Services at **TURCK USA**: media@turck.com

New Literature from TURCK



Proximity Sensors B2000

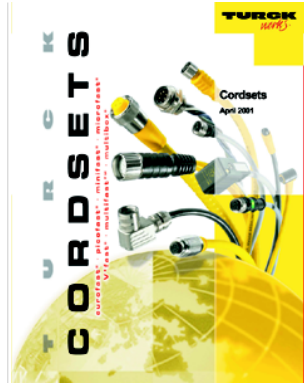

Cordsets B2001



Automation Controls B0154



Flow & Temperature B0155



Die Guard B1777



EZ-Track B0310



Capacitive Sensors B0149



Q-pak B0143



Pressure Sensors B0148

The Industry Leader in Proximity Sensing, Cordsets and Interface Technology

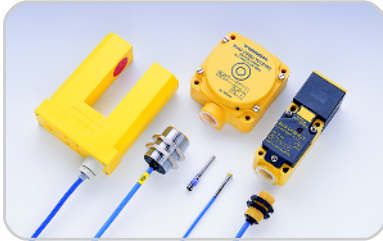

Proximity Sensors

Industry's broadest line of inductive and capacitive proximity sensors

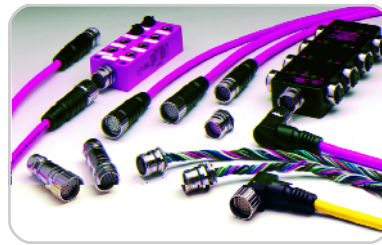

Cordsets and Junctions

Cordsets and junction boxes for connection to most popular switch and sensor styles.

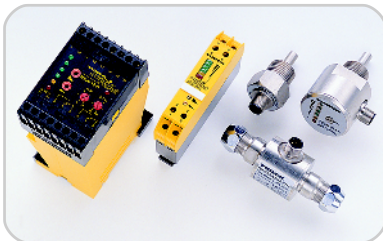

Flow Monitors

Monitors for sensing the flow of liquids and gases during industrial processes.



Pressure Sensors

A complete line of solid state, programmable pressure sensors.

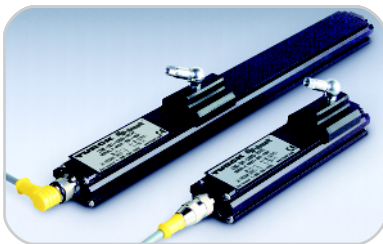

EZ-Track LDT's

Programmable Linear Displacement Transducers in a compact low profile housing.

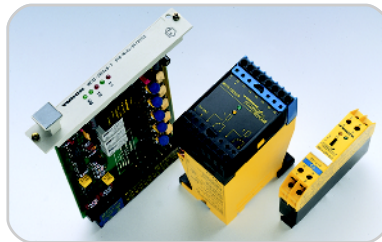

Interface Devices

Interface and logic products for automation and intrinsically safe environments.



TURCK
works

**Contact us or visit our website
for our latest literature.**

Sensor Products

email: sensors@turck.com

Cordset and Junction Products

email: cordsets@turck.com

Intrinsic Safety Products

email: barriers@turck.com

TIP
wizard
www.turck.com

TURCK USA

TURCK Inc.
3000 Campus Drive
Minneapolis, MN 55441
Phone: (763) 553-7300
FAX: (763) 553-0708
Application Support:
1-800-544-PROX (7769)

TURCK Canada

CHARTWELL
ELECTRONICS, INC.
140 Duffield Drive
Markham, Ontario
Canada, L6G 1B5
Phone: (905) 513-7100
FAX: (905) 513-7101

TURCK Mexico

ICESA - MODICON
Ant. Camino a Sta. Monica No. 7
San Lucas Tepetlcalco
54050 Tlalnepantla
Edo. de Mexico
Phone: (52) 5-397 8644
FAX: (52) 5-398 9888