

Capacitive sensor BC5-S18-Y1X

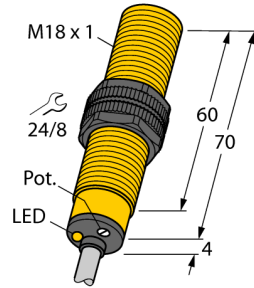

- ATEX category II 2 G, Ex zone 1
- ATEX category II 1 D, Ex zone 20
- SIL2 (Low Demand Mode) acc. to IEC 61508, PL c acc. to ISO 13849-1 at HFT0
- SIL3 (All Demand Mode) acc. to IEC 61508, PL e acc. to ISO 13849-1 with redundant configuration HFT1
- M18 × 1 threaded barrel
- Plastic, PA12-GF30
- Fine adjustment via potentiometer
- DC 2-wire, nom. 8.2 VDC
- Output acc. to DIN EN 60947-5-6 (NAMUR)
- Cable connection

Type designation	BC5-S18-Y1X
Ident-No.	20060
Rated switching distance (flush)	5 mm
Rated switching distance (non-flush)	7.5 mm
Secured operating distance	≤ (0.72 × S _n) mm
Hysteresis	1...20 %
Temperature drift	type 20 %
Repeat accuracy	≤ 2 % of full scale
Ambient temperature	-25...+70 °C
Voltage	Nom. 8.2 VDC
Current consumption non-actuated	≤ 1.2 mA
Actuated current consumption	≥ 2.1 mA
Switching frequency	0.1 kHz
Output function	2-wire, NAMUR
Approvals	TIIS CSA FM IECEX NEPSI CE INMETRO KOSHA GOST ATEX KEMA 02 ATEX 1090X 150 nF/150 μH Ⓢ II 2 G Ex ia IIC T6 Gb / II 1 D Ex ia IIIC T115 °C Da (max. U _i = 20 V, I _i = 20 mA, P _i = 200 mW)
Approval acc. to	
Internal capacitance (C _i)/inductance (L)	
Device marking	
Design	Threaded barrel, M18 × 1
Dimensions	74 mm
Housing material	Plastic, PA12-GF30, PEI
Active area material	Plastic, PA12-GF30, yellow
Admissible pressure on front cap	≤ 6 bar
Max. tightening torque housing nut	2 Nm
Electrical connection	Cable
Cable quality	Ø 5.2mm, LifYY, PVC, 2
Cable cross section	2 × 0.34 mm ²
Vibration resistance	55 Hz (1 mm)
Shock resistance	30 g (11 ms)
Protection class	IP67
MTTF	448 years acc. to SN 29500 (Ed. 99) 40 °C
Packaging unit	1
Switching state	LED, Yellow

Wiring Diagram

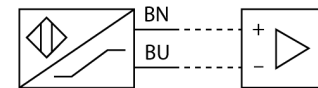

Functional principle

Capacitive proximity switches are designed for non-contact and wear-free detection of electrically conductive as well as non-conductive metal objects.

Capacitive sensor BC5-S18-Y1X

Mounting instructions/Description	minimum distances
Distance D	36 mm
Distance W	15 mm
Distance S	27 mm
Distance G	30 mm

Diameter active area B	Ø 18 mm
------------------------	---------

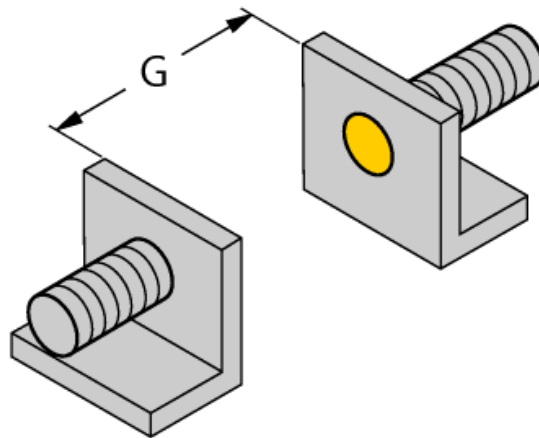

The given minimum distances have been checked against the standard switching distance. Should the sensitivity of the sensors be changed via potentiometer, the data sheet specifications no longer apply.

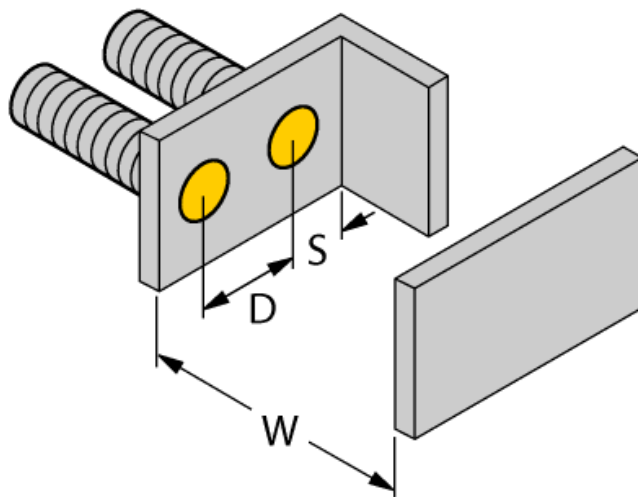

Capacitive sensor
BC5-S18-Y1X



Accessories

Type code	Ident-No.	Description	
BS-18	69471	Mounting bracket for threaded barrel devices; material: PA66-GF	
BSN 18	69472	Fixing clamp; material: PA66-GF	
BST-18B	6947214	Fixing clamp for threaded barrel devices, with dead-stop; material: PA6	
MAP-M18	6950012	Mounting adapter; material: Polypropylene; sensor replacement with filled container possible (adapter remains in container during sensor replacement)	
IMX12-DI01-2S-2T-0/24VDC	7580020	Isolating switching amplifier, 2-channel; SIL2 acc. to IEC 61508; Ex-proof version; 2 transistor outputs; input Namur signal; ON/OFF switchable monitoring of wire-break and short-circuit; toggle between NO/NC mode; signal doubling; removable screw terminals; 12.5 mm wide; 24 VDC power supply	

Capacitive sensor

BC5-S18-Y1X

TURCK
works

Industrial
Automation

Operating manual

Intended use

This device fulfills the directive 2014/34/EC and is suited for use in explosion hazardous areas according to EN 60079-0:2012 + A11 and EN 60079-11:2012.

Further it is suited for use in safety-related systems, including SIL2 as per IEC 61508.

In order to ensure correct operation to the intended purpose it is required to observe the national regulations and directives.

For use in explosion hazardous areas conform to classification

II 2 G and II 1 D (Group II, Category 2 G, electrical equipment for gaseous atmospheres and category 1 D, electrical equipment for dust atmospheres).

Marking (see device or technical data sheet)

Ⓔ II 2 G and Ex ia IIC T6 Gb acc. to EN60079-0 and -26 und Ⓔ II 1 D Ex ia IIIC T115°C Da acc. to EN60079-0

Local admissible ambient temperature

-25...+70 °C

Installation/Commissioning

These devices may only be installed, connected and operated by trained and qualified staff. Qualified staff must have knowledge of protection classes, directives and regulations concerning electrical equipment designed for use in explosion hazardous areas.

Please verify that the classification and the marking on the device comply with the actual application conditions.

This device is only suited for connection to approved Exi circuits according to EN 60079-0 and EN 60079-11. Please observe the maximum admissible electrical values.

After connection to other circuits the sensor may no longer be used in Exi installations. When interconnected to (associated) electrical equipment, it is required to perform the "Proof of intrinsic safety" (EN60079-14).

Attention! When used in safety systems, all content of the security manual must be observed.

Installation and mounting instructions

Avoid static charging of cables and plastic devices. Please only clean the device with a damp cloth. Do not install the device in a dust flow and avoid build-up of dust deposits on the device.

If the devices and the cable could be subject to mechanical damage, they must be protected accordingly. They must also be shielded against strong electro-magnetic fields.

The pin configuration and the electrical specifications can be taken from the device marking or the technical data sheet.

Service/Maintenance

Repairs are not possible. The approval expires if the device is repaired or modified by a person other than the manufacturer. The most important data from the approval are listed.