

## Flow monitoring

### Immersion sensor with integrated processor

#### FCS-G1/2A4-AP8X-H1141

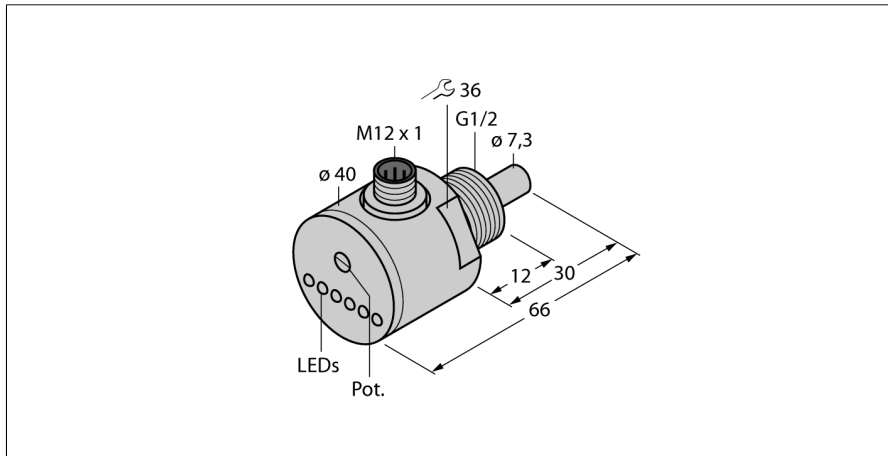

- Flow sensor for liquid media
- Calorimetric principle
- Adjustment via potentiometer
- LED band
- DC 3-wire, 19.2...28.8 VDC
- NO contact, PNP output
- Connector device, M12 × 1

#### Wiring Diagram

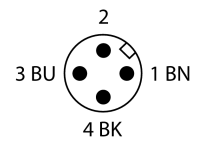
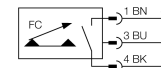

<b>Type designation</b>	FCS-G1/2A4-AP8X-H1141
Ident-No.	6870004
<b>Mounting conditions</b>	Immersion sensor
<b>Operating voltage</b>	19.2...28.8 VDC
Short-circuit protection	yes
Voltage drop at $I_n$	≤ 1.5 V
<b>Housing material</b>	Stainless steel, V4A (1.4571)
Max. tightening torque housing nut	30 Nm
Electrical connection	Connectors, M12 × 1
Protection class	IP67
Packaging unit	1
<b>Switching state</b>	LED chain, Green/Yellow/Red

#### Functional principle

Our insertion - flow sensors operate on the principle of thermodynamics. The measuring probe is heated by several °C as against the flow medium. When fluid moves along the probe, the heat generated in the probe is dissipated. The resulting temperature is measured and compared to the medium temperature. The flow status of every medium can be derived from the evaluated temperature difference. Thus TURCK's wear-free flow sensors reliably monitor the flow of gaseous and liquid media.