

# FCS-K20-AP8X-H1141/3M

## Flow Monitoring – Immersion Sensor with Integrated Processor

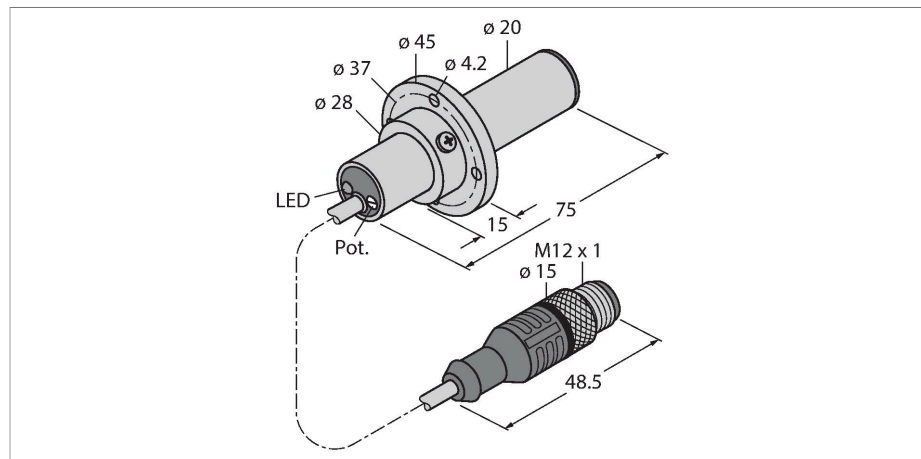

### Features

- Flow sensor for gaseous media
- Calorimetric principle
- Adjustment via potentiometer
- Mounting flange, plastic, included
- Status display via 2-color LED
- Plastic sensor housing
- DC 3-wire, 19.2...28.8 VDC
- NO contact, PNP output
- Cable device with molded M12 × 1 male connector

### Functional principle

Our insertion - flow sensors operate on the principle of thermodynamics. The measuring probe is heated by several °C as against the flow medium. When fluid moves along the probe, the heat generated in the probe is dissipated. The resulting temperature is measured and compared to the medium temperature. The flow status of every medium can be derived from the evaluated temperature difference. Thus TURCK's wear-free flow sensors reliably monitor the flow of gaseous and liquid media.

### Technical data

Ident. no.	100001097
Type	FCS-K20-AP8X-H1141/3M
<b>Mounting</b>	Immersion sensor
Air Operating Range	0.5...15 m/s
Switch-on time	typ. 2 s (1...20 s)
Switch-off time	typ. 2 s (1...20 s)
Temperature gradient	≤ 200 K/min
Medium temperature	-20...+70 °C
Ambient temperature	0...+60 °C
<b>Operating voltage</b>	19.2...28.8 VDC
Current consumption	≤ 70 mA
Output function	PNP, NO contact
Rated operational current	0.4 A
Short-circuit protection	yes
Reverse polarity protection	yes
Protection class	IP67
MTTF	637 years acc. to SN 29500 (Ed. 99) 40 °C
Design	Immersion
<b>Housing material</b>	Plastic, PBT-GF30-V0
Sensor material	Plastic, PBT-GF30-V0
Electrical connection	Cable with connector, M12 × 1
Cable length (L)	3 m
Core cross-section	3 x 0.5 mm <sup>2</sup>
Process Pressure	1 bar

## Technical data

Process connection	PVC flange
Switching state	2-color LED, Red/Green