

Flow Rate Measurement

Inline sensor with integrated processor

FTCI-18D15A4P-LI-UP8X-H1141

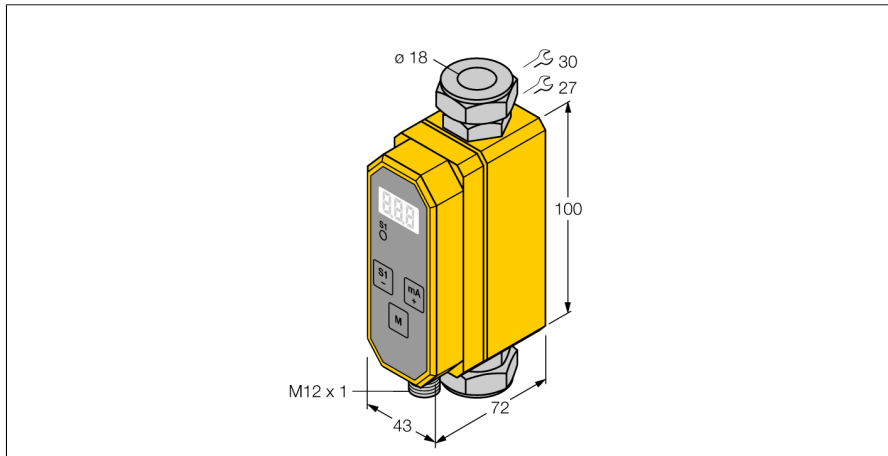

- Compact inline flow sensor
- Calorimetric principle
- Monitoring of flow rate
- Monitoring of the medium temperature
- For water/glycol mix
- Parametrized via button
- Protected by software code
- DC 4-wire, 21.6...26.4 VDC
- NO/NC prog., PNP output
- 4...20 mA analog output
- Analog output provides a current signal proportional to the flow rate for the overall operating range
- Plug-in device, M12 x 1

Type designation	FTCI-18D15A4P-LI-UP8X-H1141
Ident-No.	6870046

Mounting conditions	Inline sensor
----------------------------	---------------

Operating voltage	21.6...26.4 VDC
Short-circuit protection	yes
Current output	4...20 mA

Housing material	Plastic, PBT
Electrical connection	Connectors, M12 x 1
Protection class	IP65
Packaging unit	1

Wiring Diagram

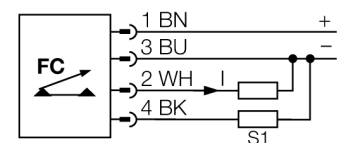

Functional principle

The FTCTs from TURCK monitor flow rates of liquids passing through the sensor reliably and wear-free. These sensors are designed for high-precision flow rate measurement rather than simple flow monitoring tasks.

Based on the thermodynamic principle, electrical energy is converted in heat energy. The heat generated in the probe is conducted away by the flowing medium. The dissipated heat quantity is used as a direct measure for the medium's flow speed. The integrated microprocessor evaluates the data and calculates the flow rate. Based on the applied principle, the user is also indicated the media temperature.

In addition to the standardized electrical output signals for industrial applications, the TURCK flow meters also indicated the current flow rate on its 3-digit 7-segment display.

Flow Rate Measurement
Inline sensor with integrated processor
FTCI-18D15A4P-LI-UP8X-H1141



Accessories

Type code	Ident-No.	Description
FTCI-G1/2A4-D18/L068	6870150	Adapter for G1/2 thread made of stainless steel A4 (1.4571/ AISI 316Ti)
FTCI-MP01AL	6870040	aluminium mounting panel for front mounting

