

# BI20-Q20-AP45X2LD

## Inductive Sensor – For Use in Vehicle Board Nets

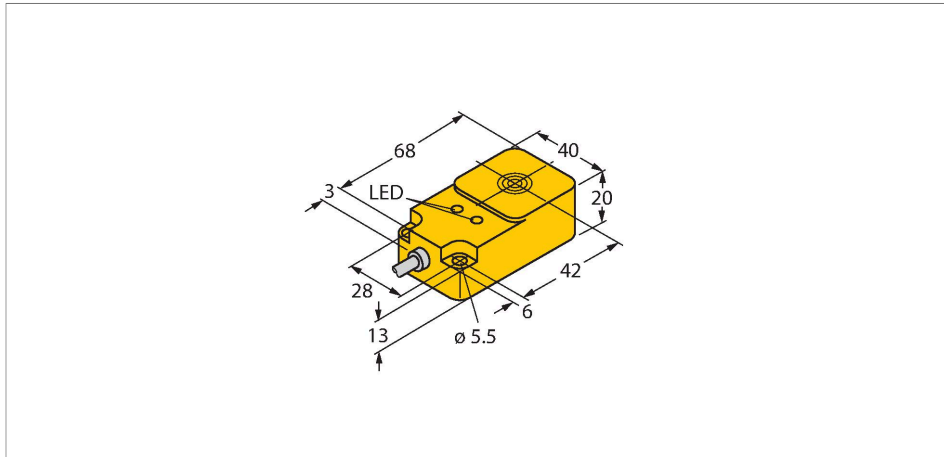

### Features

- Rectangular, height 20 mm
- Active face on top
- Plastic, PBT-GF30-V0
- For vehicle board nets, 12 V and 24 V
- Increased interference immunity 100 V/m radiated acc. ISO 11452-4 and 100 mA BCI acc. to ISO 11452-2
- Load-dump protection acc. to DIN ISO 7637-2 (SAE J 113-11)
- Extended temperature range
- High protection class IP68/IP69K
- Protection against salt spray and rapid temperature change
- Laser engraved label, permanently legible
- DC 3-wire, 8.4...65 VDC
- NO contact, PNP output
- Cable connection
- E1 type approval from German federal office for motor vehicles

### Technical data

Type	BI20-Q20-AP45X2LD
Ident. no.	1584041
Rated switching distance	20 mm
Mounting conditions	Flush
Secured operating distance	$\leq (0.81 \times S_n)$ mm
Correction factors	St37 = 1; Al = 0.3; stainless steel = 0.7; Ms = 0.4
Repeat accuracy	$\leq 2\%$ of full scale
Temperature drift	$\leq \pm 10\%$ $\leq \pm 15\%$ , $\leq -25^\circ\text{C}$ v $\geq +70^\circ\text{C}$
Hysteresis	3...15 %
Ambient temperature	-40...+85 °C
Temperature changes (EN60068-2-14)	-40...+85 °C; 20 cycles
Operating voltage	8.6...65 VDC
Residual ripple	$\leq 10\%$ $U_{ss}$
DC rated operational current	$\leq 200$ mA
No-load current	$\leq 15$ mA
Residual current	$\leq 0.1$ mA
Isolation test voltage	$\leq 0.5$ kV
Short-circuit protection	yes / Cyclic
Voltage drop at $I_e$	$\leq 1.8$ V
Wire breakage/Reverse polarity protection	yes / Complete
Output function	3-wire, NO contact, PNP
Load-dump protection (DIN ISO 7637-2)	Severity degree IV / Level 4
Switching frequency	0.5 kHz

### Wiring diagram

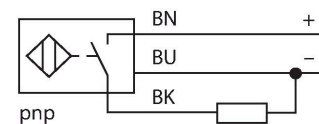

### Functional principle

Maximum reliability even under the most extreme environmental conditions is guaranteed by our sensors for mobile applications. TURCK's inductive sensors for extremely hostile industrial environments not only meet, but even exceed the requirements of the protection classes IP68 and IP69.

Applied in vehicles for road construction or in agricultural machines, these sensors excel in high vibration and shock resistance and they withstand fast temperature cycles.

12 V Bordnet						
Impulse	1	2	3a	3b	4	5
Severity level	IV	IV	IV	IV	IV	IV
Failure criterion	C	C	A	A	C	C

24 V Bordnet						
Impulse	1	2	3a	3b	4	5
Severity level	III	IV	IV	IV	III	IV
Failure criterion	C	C	A	A	A	C

## Technical data

Design	Rectangular, Q20
Dimensions	68 x 40 x 20 mm
Housing material	Plastic, PBT-GF30-V0
Active area material	PBT-GF30-V0
Electrical connection	Cable
Cable quality	Ø 5.2 mm, Lif32Y32Y, TPE, 2 m
Core cross-section	3 x 0.5 mm <sup>2</sup>
Vibration resistance	55 Hz (1 mm)
Vibration resistance (EN 60068-2-6)	20 g; 10...3000 Hz; 50 cycles; 3 axes
Shock resistance	30 g (11 ms)
Shock resistance (EN 60068-2-27)	150 g (6 ms) ½ sine; 3 x each; 3 axes
Continuous shock resistance (EN 60068-2-29)	100 g (11 ms) ½ sine; 3 x each; 3 axes
Salt spray test (EN 60068-2-52)	severity degree 5 (4 test cycles)
Protection class	IP68 / IP69K
MTTF	2283 years acc. to SN 29500 (Ed. 99) 40 °C
Power-on indication	LED, Green
Switching state	LED, Yellow

## Mounting instructions

Mounting instructions/Description		
	Distance D	1.5 x B
	Distance W	3 x Sn
	Distance S	1 x B
	Distance G	6 x Sn
	Width active area B	40 mm

## Accessories

MW-Q14/Q20

6945006

Mounting bracket for rectangular Q14  
or Q20; material VA 1.4301