

# BID2-G180-AP6-H1141/S212

## Inductive Sensor – For High Pressures

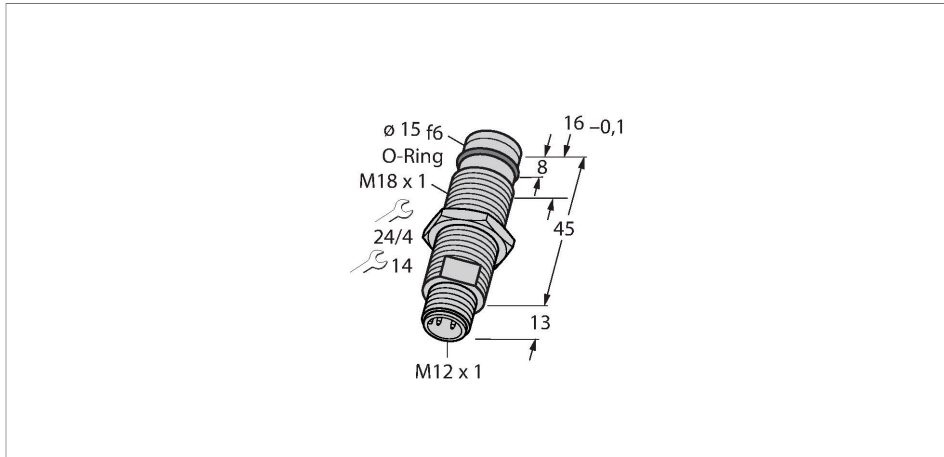

### Features

- Threaded barrel, M18 x 1
- Stainless steel, 1.4305
- Admissible pressure static/dynamic 500/350 bar
- DC 3-wire, 10...30 VDC
- NO contact, PNP output
- M12 x 1 male connector

### Wiring diagram

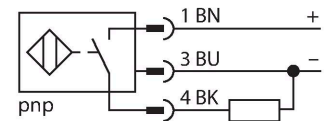

### Technical data

Type	BID2-G180-AP6-H1141/S212
Ident. no.	16885
Special version	S212 corresponds to: new production technology (core and coil encapsulated)
Rated switching distance	2 mm
Mounting conditions	Flush
Secured operating distance	$\leq (0.81 \times S_n)$ mm
Correction factors	St37 = 1; Al = 0.3; stainless steel = 0.7; Ms = 0.4
Repeat accuracy	$\leq 2\%$ of full scale
Static pressure	$\leq 500$ bar
Dynamic pressure	$\leq 350$ bar
Admissible contact medium	electrically non-conductive
Temperature drift	$\leq \pm 10\%$
Hysteresis	3...15 %
Ambient temperature	-25...+85 °C
Operating voltage	10...30 VDC
Residual ripple	$\leq 10\% U_{ss}$
DC rated operational current	$\leq 200$ mA
No-load current	$\leq 15$ mA
Residual current	$\leq 0.1$ mA
Isolation test voltage	$\leq 0.5$ kV
Short-circuit protection	yes / Cyclic
Voltage drop at $I_e$	$\leq 1.8$ V
Wire breakage/Reverse polarity protection	yes / Complete

### Functional principle

Inductive sensors detect metal objects contactless and wear-free. For this purpose they use a high-frequency electromagnetic AC field that interacts with the target. The sensors hosting a ferrite core coil generate the AC field through an LC resonant circuit. Pressure resistant inductive sensors withstand pressures of up to 500 bar which makes them perfectly suited for position control in hydraulic cylinders.

## Technical data

Output function	3-wire, NO contact, PNP
Switching frequency	2 kHz
<b>Design</b>	<b>Threaded barrel, M18 × 1</b>
Dimensions	58 mm
Housing material	Metal, V2A (1.4305)
Active area material	Plastic, PA12-GF30
Max. tightening torque housing nut	25 Nm
Electrical connection	Connector, M12 × 1
Vibration resistance	55 Hz (1 mm)
Shock resistance	30 g (11 ms)
Protection class	IP67
MTTF	1804 years acc. to SN 29500 (Ed. 99) 40 °C

## Mounting instructions

### Mounting instructions/Description

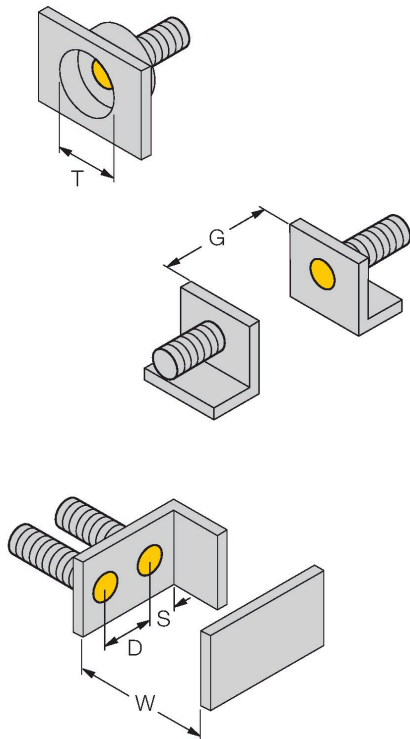

Distance D	2 x B
Distance W	3 x Sn
Distance T	3 x B
Distance S	1.5 x B
Distance G	6 x Sn
Diameter active area B	Ø 18 mm

## Wiring accessories

Dimension drawing	Type	Ident. no.	
	RKC4T-2/TEL	6625010	Connection cable, female M12, straight, 3-pin, cable length: 2 m, sheath material: PVC, black; cULus approval; other cable lengths and qualities available, see <a href="http://www.turck.com">www.turck.com</a>

