

DTBI5U-M18E-AP4X3

Inductive Sensor – Rotation speed monitor

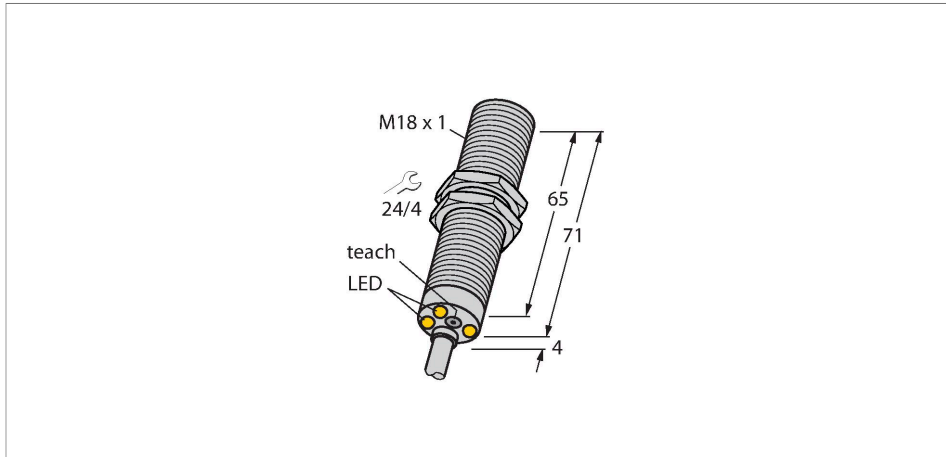

Features

- Threaded barrel, M18 x 1
- Chrome-plated brass
- Large monitoring range of 3 to 3000 1/min
- Adjustable via pushbutton [T]
- Fixed start-up time delay 5 s
- Resistant to magnetic fields
- DC 3-wire, 10...65 VDC
- NO contact, PNP output
- Cable connection

Wiring diagram

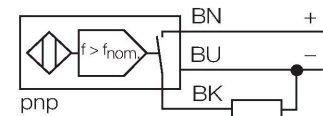

Technical data

Type	DTBI5U-M18E-AP4X3
Ident. no.	1582237
Rotational speed range, adjustable	0.05...50 Hz
	adjustable via button
Hysteresis (rotational-speed range)	3...15 %
Rated switching distance	5 mm
Mounting conditions	Flush
Secured operating distance	$\leq (0.81 \times S_n)$ mm
Repeat accuracy	$\leq 2\%$ of full scale
Temperature drift	$\leq \pm 10\%$
	$\leq \pm 15\%$, $\leq -25\text{ °C}$ v $\geq +70\text{ °C}$
Hysteresis	3...15 %
Ambient temperature	-30...+85 °C
Operating voltage	10...65 VDC
Residual ripple	$\leq 10\%$ U_{ss}
DC rated operational current	≤ 200 mA
No-load current	≤ 20 mA
Residual current	≤ 0.1 mA
Isolation test voltage	≤ 0.5 kV
Short-circuit protection	yes / Cyclic
Voltage drop at I_e	≤ 1.8 V
Wire breakage/Reverse polarity protection	yes / Complete
Output function	3-wire, NO contact, PNP
Insulation class	□

Functional principle

The rotational speed is detected by periodic damping of the integrated inductive sensor. This can be accomplished via metal targets or teeth on the monitored shaft. The pulse sequence generated is compared to an adjustable reference value in a comparator circuit. If the rotational speed is below the reference value, the output is switched off (0). If the reference value is exceeded, the output is switched on (1). The start-up time delay (AÜ) is triggered by applying voltage to the device and closes the output for 5 s (start-up time of the drive).

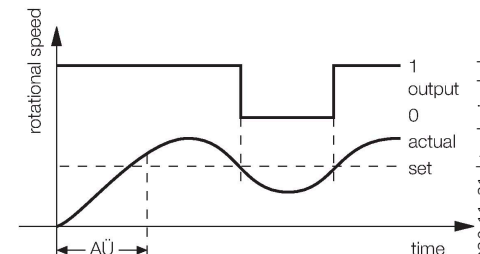

DTBI5U-M18E-AP4X3|05/27/2020 11-21 | technical changes reserved

Technical data

Design	Threaded barrel, M18 × 1
Dimensions	75 mm
Housing material	Metal, CuZn, Chrome-plated
Active area material	Plastic, PBT
End cap	Plastic, EPTR
Max. tightening torque housing nut	25 Nm
Electrical connection	Cable
Cable quality	Ø 5.2 mm, LifYY, PVC, 2 m
Core cross-section	3 x 0.34 mm ²
Vibration resistance	55 Hz (1 mm)
Shock resistance	30 g (11 ms)
Protection class	IP67
Power-on indication	LED, Green
Switching state	LED, Green/Yellow/Red/Blue

Mounting instructions

Mounting instructions/Description

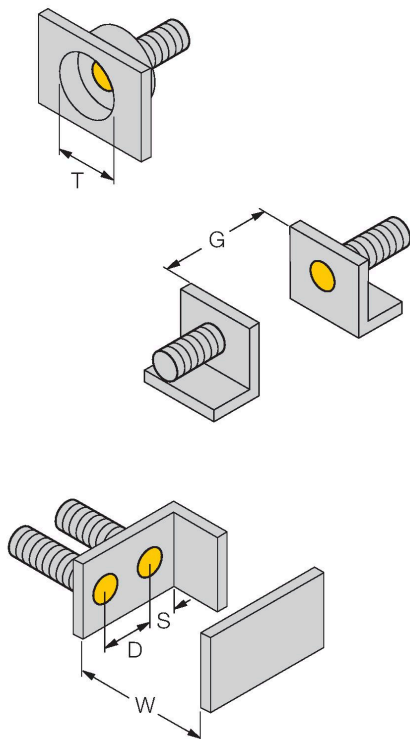

Distance D	2 x B
Distance W	3 x Sn
Distance T	3 x B
Distance S	1.5 x B
Distance G	6 x Sn
Diameter active area B	Ø 18 mm

Accessories

QM-18

6945102

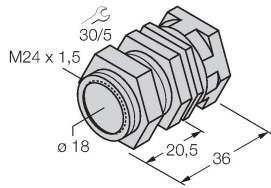

Quick-mount bracket with dead-stop; material: Chrome-plated brass. Male thread M24 × 1.5. Note: The switching distance of the proximity switches may change when using quick-mount brackets.

BST-18B

6947214

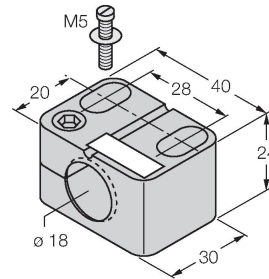

Mounting clamp for threaded barrel sensors, with dead-stop; material: PA6

MW18

6945004

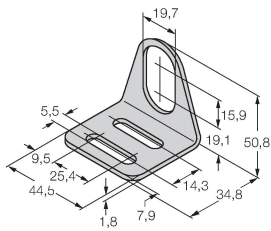

Mounting bracket for threaded barrel sensors; material: Stainless steel A2 1.4301 (AISI 304)

BSS-18

6901320

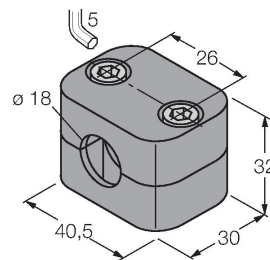

Mounting clamp for smooth and threaded barrel sensors; material: Polypropylene