

NI50-K90SR-Y1

Inductive Sensor

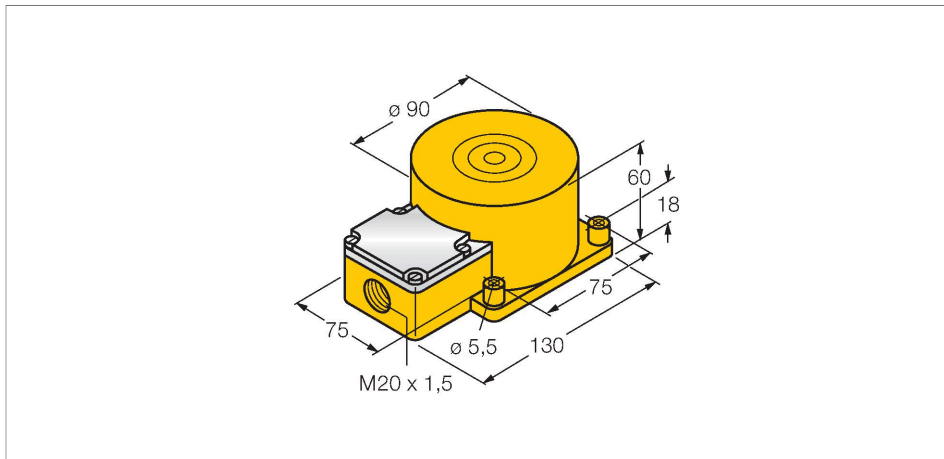

Features

- Rectangular, height 60 mm
- Plastic, PBT-GF30-V0
- DC 2-wire, nom. 8.2 VDC
- Output acc. to DIN EN 60947-5-6 (NAMUR)
- Terminal chamber
- ATEX category II 2 G, Ex zone 1
- ATEX category II 1 D, Ex zone 20
- SIL2 (Low Demand Mode) acc. to IEC 61508, PL c acc. to ISO 13849-1 at HFT0
- SIL3 (All Demand Mode) acc. to IEC 61508, PL e acc. to ISO 13849-1 with redundant configuration HFT1

Technical data

| | |
|---|---|
| Type | NI50-K90SR-Y1 |
| Ident. no. | 10074 |
| Rated switching distance | 50 mm |
| Mounting conditions | Non-flush |
| Secured operating distance | $\leq (0.81 \times S_n)$ mm |
| Correction factors | St37 = 1; Al = 0.3; stainless steel = 0.7; Ms = 0.4 |
| Repeat accuracy | $\leq 2\%$ of full scale |
| Temperature drift | $\leq \pm 10\%$ |
| Hysteresis | 1...10 % |
| Ambient temperature | -25...+70 °C |
| Output function | 2-wire, NAMUR |
| Switching frequency | 0.1 kHz |
| Voltage | Nom. 8.2 VDC |
| Non-actuated current consumption | ≥ 2.1 mA |
| Actuated current consumption | ≤ 1.2 mA |
| Approval acc. to | KEMA 02 ATEX 1090X |
| Internal capacitance (C _i)/inductance (L _i) | 250 nF/350 μ H |
| Device marking | $\text{\textcircled{Ex}}$ II 2 G Ex ia IIC T6 Gb / II 1 D Ex ia IIIC T95 °C Da (max. U _i = 20 V, I _i = 60 mA, P _i = 200 mW) |
| Warning | Avoid static charging |
| Design | Rectangular, K90SR |
| Dimensions | 130 x 75 x 60 mm |
| Housing material | Plastic, PBT-GF30-V0 |

Wiring diagram

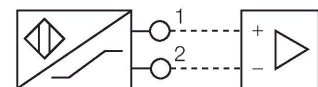

Functional principle

Inductive sensors detect metal objects contactless and wear-free. For this, they use a high-frequency electromagnetic AC field that interacts with the target. Inductive sensors generate this field via an RLC circuit with a ferrite coil.

Technical data

| | |
|-----------------------|--|
| Active area material | PBT-GF30-V0 |
| Electrical connection | Terminal chamber |
| Clamping ability | $\leq 2.5 \text{ mm}^2$ |
| Vibration resistance | 55 Hz (1 mm) |
| Shock resistance | 30 g (11 ms) |
| Protection class | IP67 |
| MTTF | 6198 years acc. to SN 29500 (Ed. 99) 40 °C |
| Included in delivery | cable gland |

Mounting instructions

| Mounting instructions/Description | | |
|-----------------------------------|---------------------|---------|
| | Distance D | 3 x B |
| | Distance W | 3 x Sn |
| | Distance S | 1.5 x B |
| | Distance G | 6 x Sn |
| | Distance N | 2 x Sn |
| | Distance A | 1 x Sn |
| | Distance C | 2 x Sn |
| | Width active area B | 90 mm |

Accessories

| | |
|--------------------------|---------|
| IMX12-DI01-2S-2T-0/24VDC | 7580020 |
|--------------------------|---------|

Isolating switching amplifier, 2-channel; SIL2 acc. to IEC 61508; Ex-proof version; 2 transistor outputs; input Namur signal; ON/OFF switchable monitoring of wire-break and short-circuit; toggle between NO/NC mode; signal doubling; removable screw terminals; 12.5 mm wide; 24 VDC power supply

Operating Instructions

Intended use

This device fulfills the directive 2014/34/EC and is suited for use in explosion hazardous areas according to EN 60079-0:2012 + A11 and EN 60079-11:2012. Further it is suited for use in safety-related systems, including SIL2 as per IEC 61508. In order to ensure correct operation to the intended purpose it is required to observe the national regulations and directives.

For use in explosion hazardous areas conform to classification

II 2 G and II 1 D (Group II, Category 2 G, electrical equipment for gaseous atmospheres and category 1 D, electrical equipment for dust atmospheres).

Marking (see device or technical data sheet)

⊕ II 2 G and Ex ia IIC T6 Gb and ⊕ II 1 D Ex ia III C T95 °C Da acc. to EN 60079-0, -11

Local admissible ambient temperature

-25...+70 °C

Installation/Commissioning

These devices may only be installed, connected and operated by trained and qualified staff. Qualified staff must have knowledge of protection classes, directives and regulations concerning electrical equipment designed for use in explosion hazardous areas. Please verify that the classification and the marking on the device comply with the actual application conditions.

This device is only suited for connection to approved Exi circuits according to EN 60079-0 and EN 60079-11. Please observe the maximum admissible electrical values. After connection to other circuits the sensor may no longer be used in Exi installations. When interconnected to (associated) electrical equipment, it is required to perform the "Proof of intrinsic safety" (EN60079-14). Attention! When used in safety systems, all content of the security manual must be observed.

Installation and mounting instructions

Avoid static charging of cables and plastic devices. Please only clean the device with a damp cloth. Do not install the device in a dust flow and avoid build-up of dust deposits on the device. If the devices and the cable could be subject to mechanical damage, they must be protected accordingly. They must also be shielded against strong electro-magnetic fields. The pin configuration and the electrical specifications can be taken from the device marking or the technical data sheet. In order to avoid contamination of the device, please remove possible blanking plugs of the cable glands or connectors only shortly before inserting the cable or opening the cable socket.

Special conditions for safe operation

avoid static charging

Service/Maintenance

Repairs are not possible. The approval expires if the device is repaired or modified by a person other than the manufacturer. The most important data from the approval are listed.