

# LI25P1-QR14-LIU5X2

## Inductive Linear Position Sensor

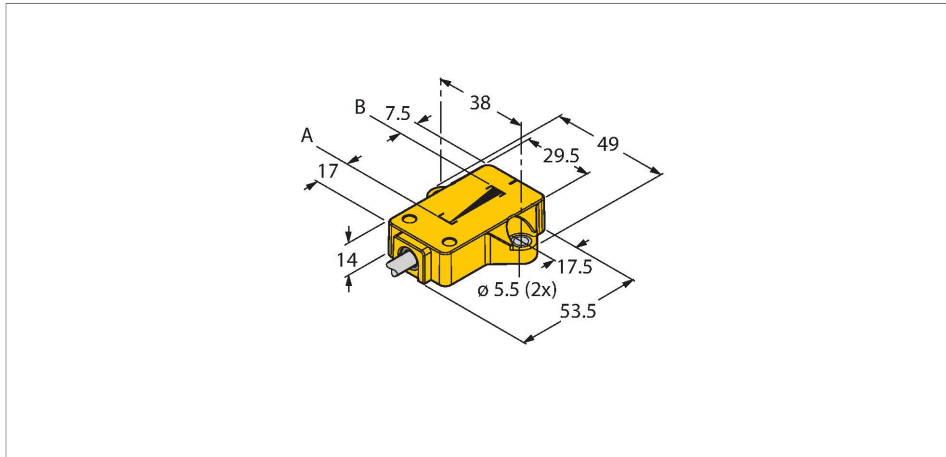

### Features

- Rectangular, plastic
- Many mounting possibilities
- P1-Ri-QR14/Q17L included in delivery
- LED indicates measuring range
- Immune to electromagnetic interference
- Extremely short blind zones
- Resolution, 12-bit
- 4-wire, 15...30 VDC
- Analog output
- 0...10 V and 4...20 mA
- Cable connection

### Wiring diagram

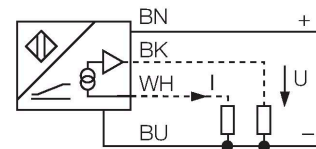

### Technical data

Type	LI25P1-QR14-LIU5X2
Ident. no.	1590751
Measuring principle	Inductive
Measuring range	25 mm
Resolution	0,006 mm/12 bit
Nominal distance	1.5 mm
Blind zone a	17 mm
Blind zone b	7.5 mm
Repeat accuracy	≤ 0.03 % of full scale
Linearity deviation	≤ 1 %f.s.
Temperature drift	≤ ± 0.01 % / K
Hysteresis	not applied
Ambient temperature	-25...+70 °C
Operating voltage	15...30 VDC
Residual ripple	≤ 10 % U <sub>ss</sub>
Isolation test voltage	≤ 0.5 kV
Short-circuit protection	yes
Wire breakage/Reverse polarity protection	yes / yes (voltage supply)
Output function	4-wire, Analog output
Voltage output	0...10 V
Current output	4...20 mA
Load resistance voltage output	≥ 4.7 kΩ
Load resistance, current output	≤ 0.4 kΩ
Sample rate	700 Hz

### Functional principle

The measuring principle of linear position sensors is based on RLC coupling between the positioning element and the sensor, whereby an output signal is provided proportional to the position of the positioning element. The rugged sensors are wear and tear-free, thanks to the contactless operating principle. They convince through their excellent repeatability, resolution and linearity within a broad temperature range. The innovative technology ensures a high immunity to electromagnetic DC and AC fields.

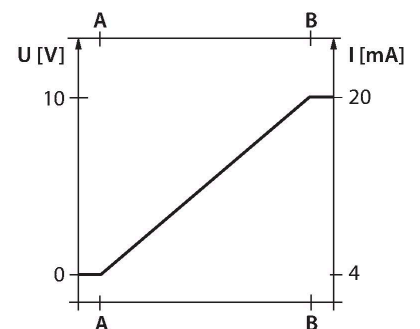

LI25P1-QR14-LIU5X2|06/17/2020 21-29 | technical changes reserved

## Technical data

Current consumption	< 50 mA
Design	Profile, QR14
Dimensions	53.5 x 49 x 14 mm
Housing material	Plastic, PBT-GF30-V0
Electrical connection	Cable
Cable quality	Ø 5.2 mm, Gray, LifYY, PVC, 2 m
Core cross-section	4 x 0.34 mm <sup>2</sup>
Vibration resistance	55 Hz (1 mm)
Shock resistance	30 g (11 ms)
Protection class	IP68 / IP69K
MTTF	138 years acc. to SN 29500 (Ed. 99) 40 °C
Power-on indication	LED, Green
Measuring range display	multifunction LED, green
Included in delivery	positioning element P1-Li-QR14/Q17L

## Mounting instructions

### Mounting instructions/Description

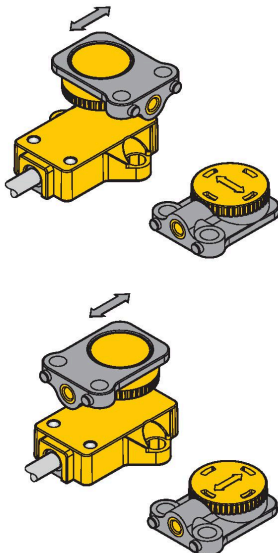

The positioning element can be mounted offset by 90°. This provides highest mounting flexibility. The measuring principle of RLC coupling makes the sensor immune to magnetized metal splinters and other interference fields.

#### LED indications

##### green

positioning element is in the measuring range

##### green flashing:

positioning element is in the measuring range, the distance is too large. This is indicated by a weaker signal

##### off

positioning element is outside the coverage.

Accessories

P1-LI-QR14/Q17L

1590724

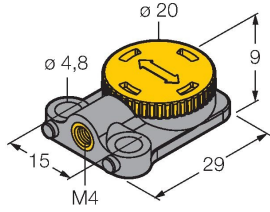

Floating positioning element for linear position sensors LI-QR14 and LI-Q17L; transverse and longitudinal mounting possible; the nominal distance to the sensor is 1.5 mm; pairing with the linear position sensor at a distance of up to 3 mm or a misalignment tolerance of up to 3 mm