

# BIM-QST-AP6X

## Magnetic Field Sensor – For Pneumatic Cylinders

### Features

- Rectangular, height 12 mm
- Front active face
- Plastic, PA12-GF30
- Magnetic-inductive sensor
- DC 3-wire, 10...30 VDC
- NO contact, PNP output
- Cable connection

### Wiring diagram

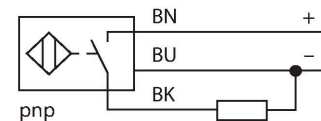

### Functional principle

Magnetic field sensors are activated by magnetic fields and are especially suited for piston position detection in pneumatic cylinders. Based on the fact that magnetic fields can permeate non-magnetizable metals, it is possible to detect a permanent magnet attached to the piston through the aluminium wall of the cylinder.

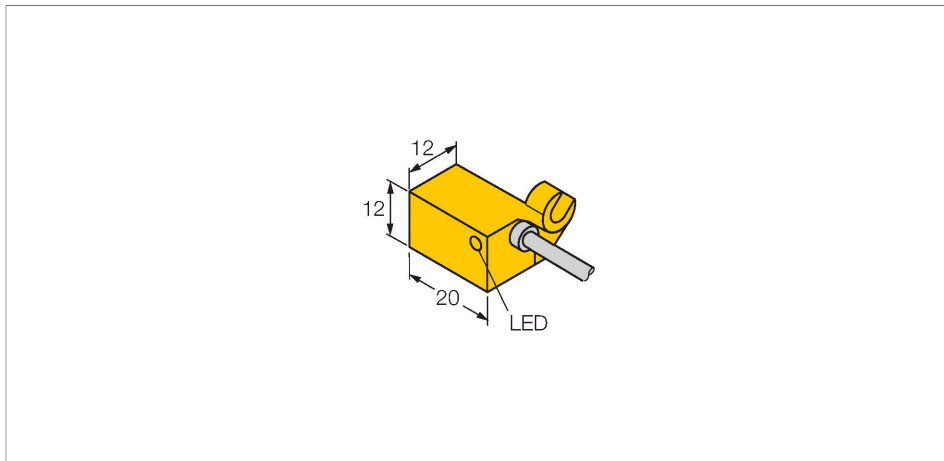

### Technical data

Type	BIM-QST-AP6X
Ident. no.	4688000
Pass speed	≤ 10 m/s
Repeatability	≤ ± 0.1 mm
Temperature drift	≤ 0.1 mm
Hysteresis	≤ 1 mm
Ambient temperature	-25...+70 °C
Operating voltage	10...30 VDC
Residual ripple	≤ 10 % U <sub>s</sub>
DC rated operational current	≤ 200 mA
No-load current	≤ 15 mA
Residual current	≤ 0.1 mA
Isolation test voltage	≤ 0.5 kV
Short-circuit protection	yes / Cyclic
Voltage drop at I <sub>e</sub>	≤ 1.8 V
Wire breakage/Reverse polarity protection	yes / Complete
Output function	3-wire, NO contact, PNP
Switching frequency	1 kHz
<b>Design</b>	<b>Rectangular, QST</b>
Dimensions	20 x 12 x 12 mm
Housing material	Plastic, PA12-GF30
Active area material	Plastic, PA12-GF30
Electrical connection	Cable
Cable quality	Ø 4 mm, Gray, LifYY, PVC, 2 m

## Technical data

Core cross-section	3 x 0.25 mm <sup>2</sup>
Vibration resistance	55 Hz (1 mm)
Shock resistance	30 g (11 ms)
Protection class	IP67
MTTF	2283 years acc. to SN 29500 (Ed. 99) 40 °C
<b>Mounting on the following profiles</b>	
Cylindrical design	# 
Switching state	LED, Yellow

## Accessories

**KLQ1Z** 6971911

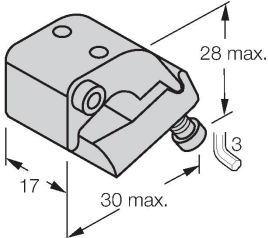

Mounting bracket for mounting magnetic field sensors on tie-rod cylinders; cylinder diameter 32... 63 mm; material: Anodized aluminum; please order mounting bracket separately

**KLQ2Z** 6971912

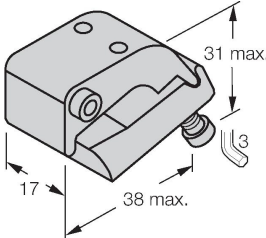

Mounting bracket for mounting magnetic field sensors on tie-rod cylinders; cylinder diameter 50... 125 mm, material: Anodized aluminum; please order mounting bracket separately

**KLQ1** 6971901

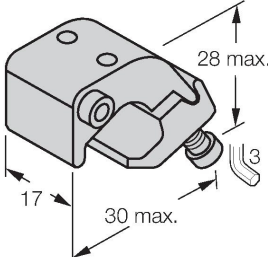

Mounting bracket for mounting magnetic field sensors on profile cylinders; cylinder diameter 32... 50 mm; material: Anodized aluminum; please order mounting bracket separately

**KLQ2** 6971902

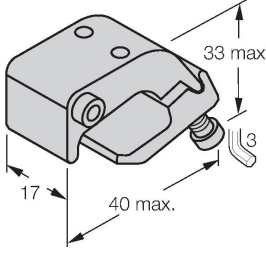

Mounting bracket for mounting magnetic field sensors on profile cylinders; cylinder diameter 50... 100 mm; material: Anodized aluminum; please order mounting bracket separately