

NIMFE-EM12/4.0L61-UP6X-H1141/S1182

Magnetic field sensor – With TIN Coating

For Detection of Ferromagnetic Parts

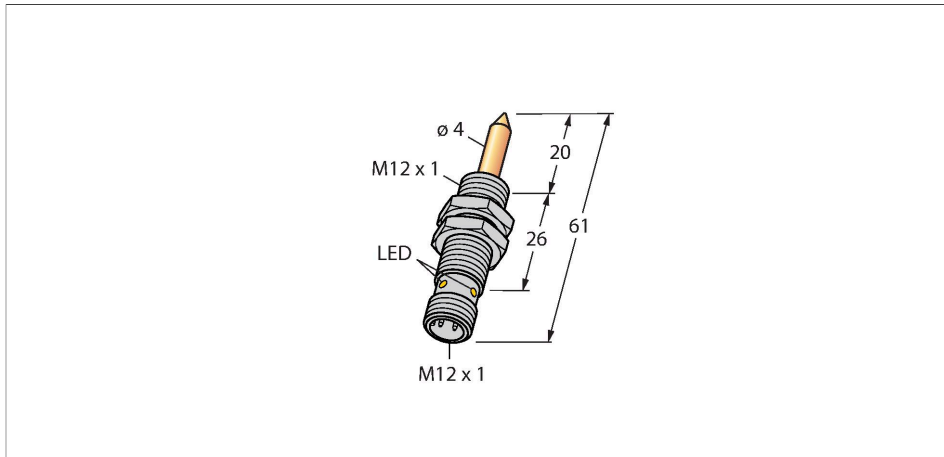

Features

- Threaded barrel, M12 x 1
- Stainless steel, 1.4301
- DC 3-wire, 10...30 VDC
- NC/NO parametrizable with teach adapter VB2-SP1
- M12 x 1 male connector

Wiring diagram

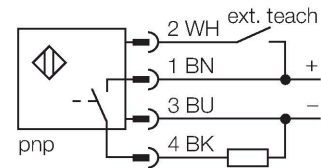

Technical data

Type	NIMFE-EM12/4.0L61-UP6X-H1141/S1182
Ident. no.	1600621
Remark to product	Optimized for the detection of weld nuts of the size of M5 to M10
Special version	S1182 corresponds to: TIN coating
Ambient temperature	-25...+70 °C
Operating voltage	10...30 VDC
Residual ripple	≤ 10 % U _{ss}
DC rated operational current	≤ 100 mA
No-load current	≤ 15 mA
Residual current	≤ 0.1 mA
Isolation test voltage	≤ 0.5 kV
Short-circuit protection	yes / Cyclic
Voltage drop at I _e	≤ 1 V
Wire breakage/Reverse polarity protection	yes / Complete
Output function	3-wire, Connection programmable, PNP
Design	Threaded barrel, M12 × 1
Dimensions	61 mm
Housing material	Stainless steel, V2A (1.4301)
Active area material	Stainless steel, V2A (1.4301), TIN coating
Max. tightening torque housing nut	10 Nm
Electrical connection	Connector, M12 × 1
Vibration resistance	55 Hz (1 mm)

Functional principle

The weld sensors are available in different versions, with different signal intensities and diameters. Ferromagnetic parts which differ strongly in their material properties and diameters can thus be detected. A component to be detected must be located within the so-called optimal sensitive area in order to be detected. This optimal sensitive area has a width of 0.5 mm and is laser-engraved on the tip of the probe, 11.9 mm above of the M12 thread.

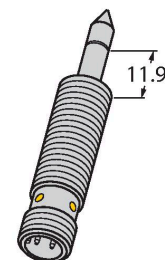

NIMFE-EM12/4.0L61-UP6X-H1141/S1182 05/27/2020 13-04 | technical changes reserved

Technical data

Shock resistance	30 g (11 ms)
Protection class	IP67
MTTF	874 years acc. to SN 29500 (Ed. 99) 40 °C
Power-on indication	LED, Green
Switching state	LED, Yellow

Mounting instructions

Mounting instructions/Description

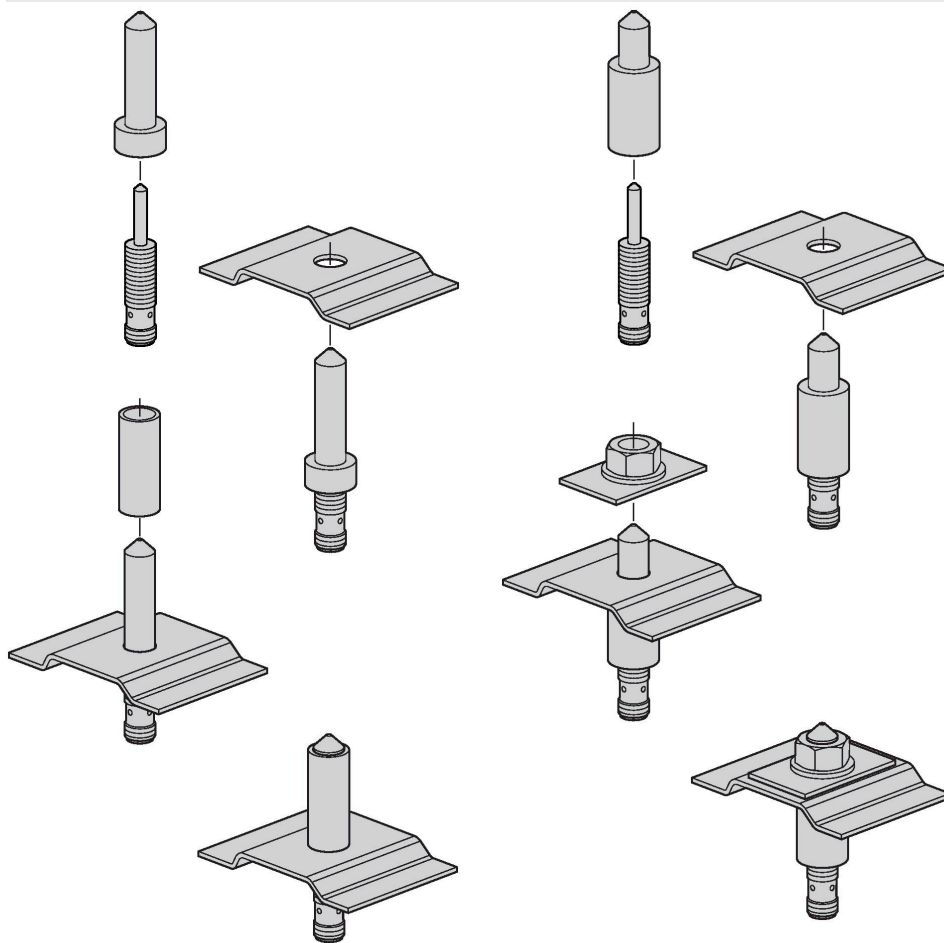

The magnetic field sensor for detection of ferromagnetic spares is especially suited for the detection of welding nuts as well as spacer or reinforcing sleeves. The parts to be detected must always consist of ferromagnetic material, so that a proper function can be guaranteed. Most applications need center bolts to tack the welding nuts and reinforcing sleeves in place and thus provide mechanical protection of the sensors. These bolts must be made of non-ferromagnetic material, like stainless steel for example. Center bolts are not available at Turck, as these have to be individually produced for and adjusted to the correspondent application.

Accessories

VB2-SP1

A3501-29

Teach adapter

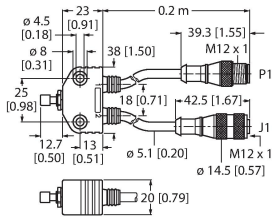

BST-12B

6947212

Mounting clamp for threaded barrel sensors, with dead-stop; material: PA6

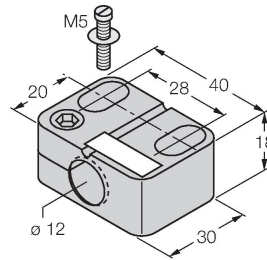

MW12

6945003

Mounting bracket for threaded barrel sensors; material: Stainless steel A2 1.4301 (AISI 304)

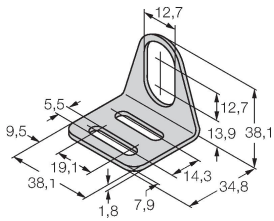

BSS-12

6901321

Mounting clamp for smooth and threaded barrel sensors; material: Polypropylene

