

NIMFE-EM12/6.2L101-UP6X-H1141/S1182

Magnetic field sensor – With TIN Coating

For Detection of Ferromagnetic Parts

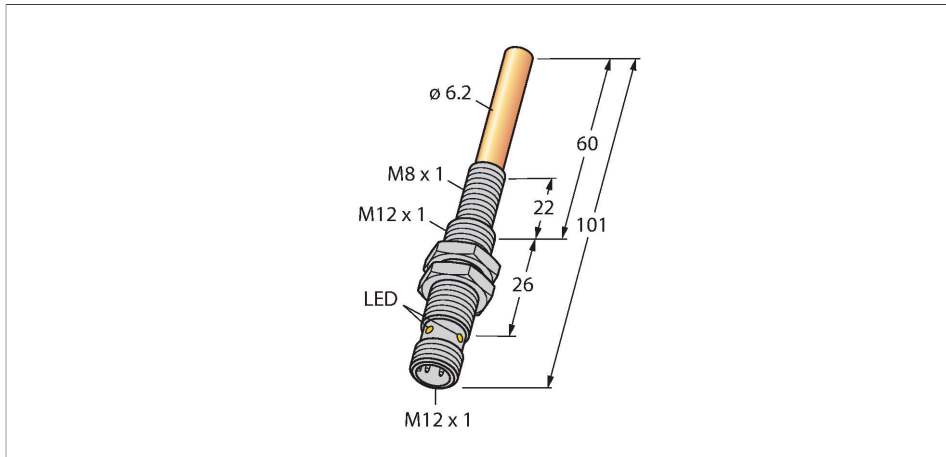

Features

- Threaded barrel, M12 x 1
- Stainless steel, 1.4301
- DC 3-wire, 10...30 VDC
- NC/NO parametrizable with teach adapter VB2-SP1
- M12 x 1 male connector

Wiring diagram

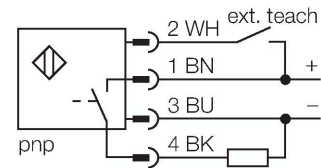

Technical data

| | |
|---|--|
| Type | NIMFE-EM12/6.2L101-UP6X-H1141/S1182 |
| Ident. no. | 1600612 |
| Special version | S1182 corresponds to: TIN coating |
| Ambient temperature | -25...+70 °C |
| Operating voltage | 10...30 VDC |
| Residual ripple | ≤ 10 % U _{ss} |
| DC rated operational current | ≤ 100 mA |
| No-load current | ≤ 15 mA |
| Residual current | ≤ 0.1 mA |
| Isolation test voltage | ≤ 0.5 kV |
| Short-circuit protection | yes / Cyclic |
| Voltage drop at I _e | ≤ 1 V |
| Wire breakage/Reverse polarity protection | yes / Complete |
| Output function | 3-wire, Connection programmable, PNP |
| Design | Threaded barrel, M12 x 1 |
| Dimensions | 101 mm |
| Housing material | Stainless steel, V2A (1.4301) |
| Active area material | Stainless steel, V2A (1.4301), TIN coating |
| Max. tightening torque housing nut | 10 Nm |
| Electrical connection | Connector, M12 x 1 |
| Vibration resistance | 55 Hz (1 mm) |
| Shock resistance | 30 g (11 ms) |

Functional principle

The weld sensors are available in different versions, with different signal intensities and diameters. Ferromagnetic parts which differ strongly in their material properties and diameters can thus be detected. A target part has to be located within the so called sensitive area in order to be detected. The internal sensor signal reaches the maximum intensity if the sensitive area is completely covered by the target. Partial coverage is also possible.

Sensitive area S = 11 mm
Within this area the sensor signal changes when components are connected.

Maximum range M = 14mm
In case of complete coverage of the sensitive area the maximum signal intensity is achieved.

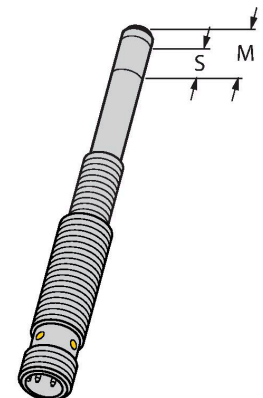

NIMFE-EM12/6.2L101-UP6X-H1141/S1182_05/27/2020 13-04 | technical changes reserved

Technical data

| | |
|---------------------|---|
| Protection class | IP67 |
| MTTF | 874 years acc. to SN 29500 (Ed. 99) 40 °C |
| Power-on indication | LED, Green |
| Switching state | LED, Yellow |

Mounting instructions

Mounting instructions/Description

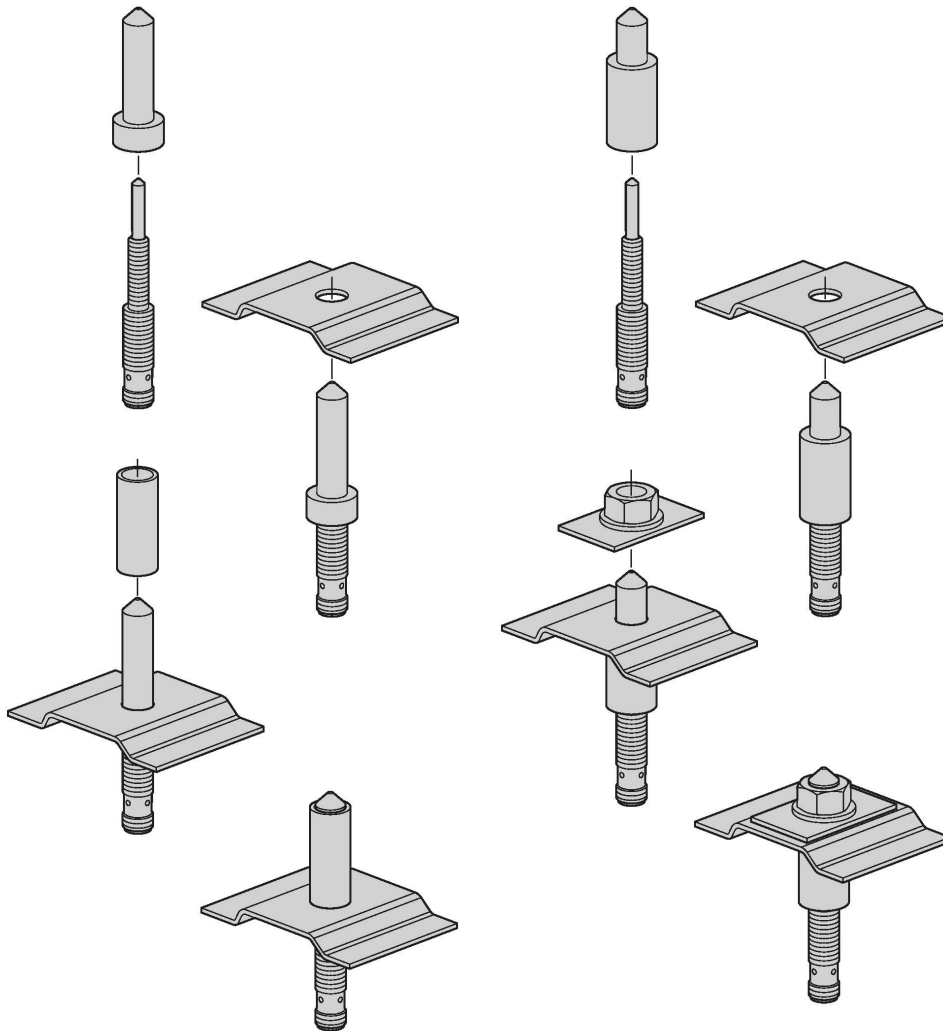

The magnetic field sensor is especially suited for the detection of welding nuts as well as spacer or reinforcing sleeves. The parts to be detected must always consist of ferromagnetic material, so that a proper function can be guaranteed. Most applications need center bolts to tack the welding nuts and reinforcing sleeves in place and thus provide mechanical protection of the sensors. These bolts have to be made of non-ferromagnetic material, like stainless steel for example. Center bolts are not available at Turck, as these have to be individually produced for and adjusted to the correspondent application.

The welding nut sensor easily detects ferritic targets with diameters between 10 mm and 20 mm.

Accessories

VB2-SP1

A3501-29

Teach adapter

