

Accessories

Mounting Bracket

For Linear Position Sensors LI-Q25L M2-Q25L

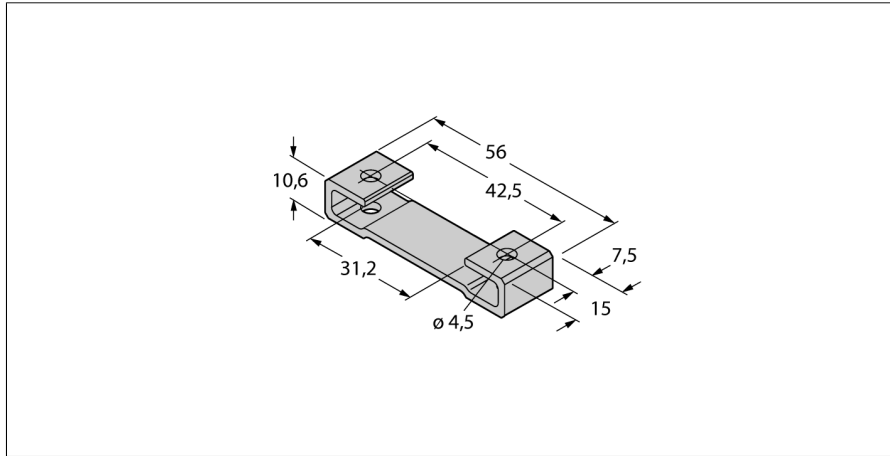

- Mounting foot for linear position sensors Q25L
- Anodized aluminum
- Packaging unit: 2 pcs.
- Recommended torque: 3 Nm

Type designation	M2-Q25L
Ident-No.	6901046
Dimensions	56 x 15.2 x 10 mm