

Accessories

Mounting Bracket

For Linear Position Sensors LI-Q25L M4-Q25L

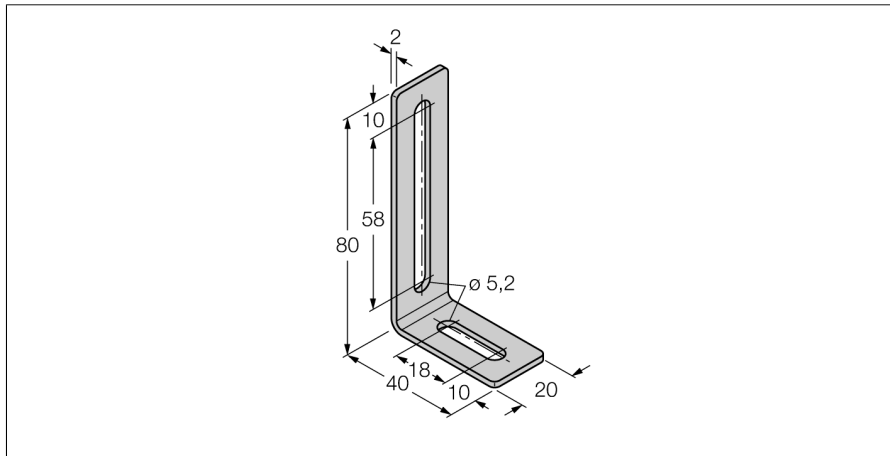

- Mounting bracket and sliding block for linear position sensors Q25L
- Stainless steel
- Packaging unit: 2 pcs.
- Incl. 2 x MN-M4-Q25

Type designation	M4-Q25L
Ident-No.	6901048
Packaging unit	2 Stück
Included in delivery	Sliding blocks and screws