

Accessories
Mounting Bracket
For Linear Position Sensors
MB2.2-Q25 (4 PCS)

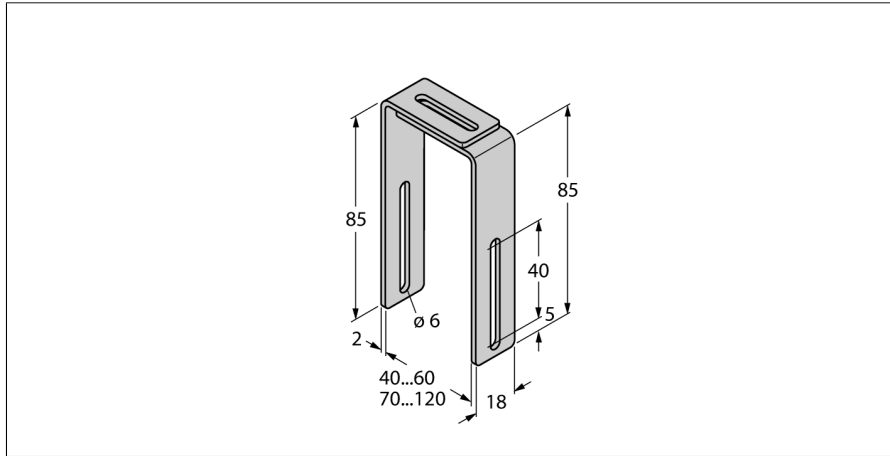

- Mounting bracket for linear position sensors Q25L for mounting on pneumatic cylinders
- For cylinder widths 70–120 mm
- For cylinder widths 40–60 mm see MB2.1-Q25

Type designation	MB2.2-Q25 (4 PCS)
Ident-No.	6901028
Design	Accessories for rectangular types
Packaging unit	4 Stück
Included in delivery	4 pcs. mounting brackets