

EN 50155 Managed PoE Switch

Viper-112A-P8-LV

- Compact 12 port switch, approved for rolling stock
 - 12x100 Mbps, whereof 8 PoE ports
 - IEEE 802.3af/at (PoE/PoE+)
- Designed and built for extreme operational environments
 - Robustness-enhancing design features
 - Extensive range of approvals, by IEC/ISO 17025 certified laboratories
 - Quality-focused engineering and production located in Sweden
- Powered by WeOS, Westermo's proven network operating system
 - Strong set of protocols and functions, including DHCP (server and client)
 - High level cyber security
 - Easy to use



EN 50121-3-2 Rolling Stock **EN 50155** On Board Rail **EN 45545-2** Fire Protection **NFPA 130** Fire Protection

The Viper-112A-P8-LV is a managed 12 port switch optimised for the needs of the railway rolling stock market. PoE ports offer effective powering of end-devices.

The Viper is designed to withstand the tough environment on-board trains, exposing the switch to constant vibration, extreme temperatures, humidity and a demanding electrical environment.

A GORE-TEX® membrane prevents internal condensation. Threading integrated in chassis provides for additional vibration resistance. High-level isolation between all interfaces enables direct connectivity to vehicle auxiliary power and protects against overvoltage and flashover. IP67 protection prevents ingress of water and dust. An overall optimised design results in an extremely compact package in combination with very high MTBF for easy integration and low lifecycle cost.

Thorough type testing at independent ISO/IEC 17025 and ILAC MRA certified labs, accredited to a wide range of standards, show that the Viper series fulfills EN 50155 and other requirements. The state-of-the-art Westermo production facility ensures the quality of each individual unit, e.g. through temperature cycling burn-in testing.

The WeOS operating system offers an extensive suite of IP networking features for resilient and flexible networks, e.g. the FRNT ring protocol with very fast failover on 100 Mbps ports. The backup device accessory matches the Viper in robustness and offers easy configuration update and backup.

Meeting the requirements of the railcar market, the Viper is very well suited for deployment in any other application with severe operating conditions and tough environments, for instance in the mining industry.

Ordering information	
Art. no.	Description
3635-0210	Viper-112A-P8-LV, EN 50155 managed PoE switch
3641-7190/-0190	M12 USB configuration backup device with/without attachment strap
3146-11xx	Patch and power cables, see www.westermo.com
1211-4073	Console cable

Specifications - Viper-112A-P8-LV

Dimensional drawing

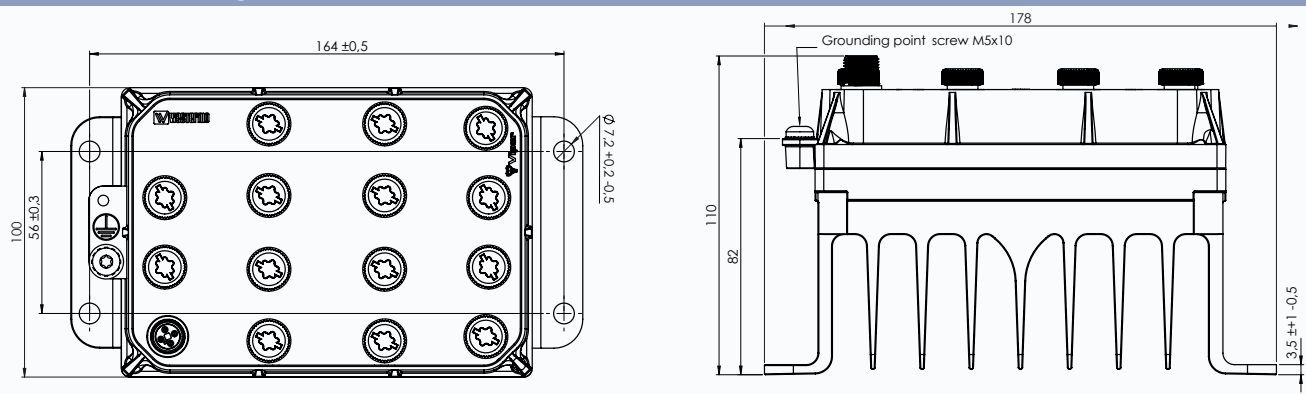

Technical data

Dimensions (W x H x D)	177 x 100 x 110 (6.97 x 3.94 x 4.33 inches)
Weight	1.7 kg
Rated voltage	24 to 38 VDC
Operating voltage	16.8 to 49.4 VDC (14.4 to 53.2 VDC for 100 ms)
Rated current	4.7 A at 24 V and 3.0 A at 38 V
Rated PoE power	Max 80 W total; max 30 W on a single port
Power interruption	Class S2 (10 ms hold-up) for switch and connected PoE devices
Ethernet ports	12x100 Mbps, whereof 8 PoE ports
Backup and restore port	1 x USB
Console port	1 x RS-232
Operating temperature	-40 to +70°C (-40 to +158°F) (operational for a limited time)
Storage and transport temperatures	-55 to +85°C (-67 to +185°F)
MTBF	404,000 hours (MIL-HDBK-217F2)
Ingress protection	IP67

Type Approval/Compliance

Type	Approval/Compliance
Climate	<ul style="list-style-type: none"> EN 50155/IEC 60571 class TX, Railway applications - Electronic equipment used on rolling stock IEEE 1478 class 1, condition E4 (incl Salt Mist), Environmental conditions for transit rail car electronic equipment
EMC	<ul style="list-style-type: none"> EN 61000-6-2, Immunity industrial environments EN 61000-6-4, Emission industrial environments EN 50121-3-2/IEC 62236-3-2 Railway applications – Rolling stock – apparatus Tested and verified for Class S1, DB EMC Regulation 06, Commodity team Radio compatibility in VDB Rev 1.0 (Shunting Radio). Compliant with SBB requirements. Tested and verified for Class S1, ÖBB Radio compatibility in near field in accordance with ÖBB Infrastructure Edition 4, Revision 14 (Shunting Radio). Tested and verified for FCC part 15
Mechanical (Shock and vibration)	<ul style="list-style-type: none"> EN 61373 category 1, class A EN 60068-2-27 20 g, 11 ms and 100 g, 6 ms
Insulation (Coordination and test)	<ul style="list-style-type: none"> EN 50124-1, Railway applications – Insulation coordination EN 50155/IEC 60571, Railway applications - Electronic equipment used on rolling stock
Fire protection	<ul style="list-style-type: none"> EN 45545-2, Fire protection on railway vehicles NFPA130, Fire protection for fixed guideway transit and passenger rail system