

USERGUIDE

Viper 008

Unmanaged 8-port Ethernet Switch

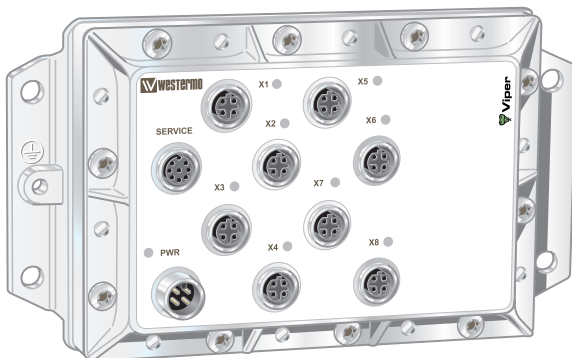

General information

Legal information

The contents of this document are provided “as is”. Except as required by applicable law, no warranties of any kind, either express or implied, including, but not limited to, the implied warranties of merchantability and fitness for a particular purpose, are made in relation to the accuracy and reliability or contents of this document. Westermo reserves the right to revise this document or withdraw it at any time without prior notice.

Under no circumstances shall Westermo be responsible for any loss of data or income or any special, incidental, and consequential or indirect damages howsoever caused.

More information about Westermo can be found at the following Internet address:
www.westermo.com

Safety



Before installation:

Read this manual completely and gather all information on the unit. Make sure that you understand it fully. Check that your application does not exceed the safe operating specifications for this unit.

This unit should only be installed by qualified personnel.

This unit should be built-in to an apparatus cabinet, or similar, where access is restricted to service personnel only. The power supply wiring must be sufficiently fused, and if necessary it must be possible to disconnect manually from all power supply. Ensure compliance to national installation regulations. This unit relies on convection cooling. Make sure that it is installed so that the ambient temperature is within the specified temperature range, e.g. by avoiding obstruction of the airflow around the unit. Also check chapter EN 45545-2 mounting notes.

The unit has no internal fuse and should be connected via an external fuse. The fuse should be calculated in accordance with the rated current.

Before mounting, using or removing this unit:

Prevent access to hazardous voltage by disconnecting the unit from all power supply.



WARNING

Do not open connected unit. Hazardous voltage may occur within this unit when connected to power supply.

Before powering-up, a protective earthing conductor must be connected to the protective earthing terminal and have a cross-sectional area of at least 1.5 mm². Note that this unit can be connected to two different power sources.

Be aware of that the surface of this unit may become hot. When this unit is operated at high temperatures, the External Surface of Equipment may exceed Touch Temperature Limit according to EN/IEC/UL 60950-1.

To reduce the risk of fire:

1. Use only No. 21 AWG or larger power cable
2. Use only No. 26 AWG or larger telecommunication line cord.

Care recommendations

Follow the care recommendations below to maintain full operation of unit and to fulfill the warranty obligations:

- ⌘ This unit must not be operating with removed covers or lids.
- ⌘ Do not attempt to disassemble the unit. There are not any user serviceable parts inside.
- ⌘ Do not drop, knock or shake the unit. Rough handling above the specification may cause damage to internal circuit boards.
- ⌘ Do not use harsh chemicals, cleaning solvents or strong detergents to clean the unit.
- ⌘ Do not expose the unit to any kind of liquid (water, beverages, paint etc). The unit is not waterproof. Keep the unit within the specified humidity levels.
- ⌘ Do not use or store the unit in dusty, dirty areas, connectors as well as other mechanical part may be damaged.
- ⌘ Do not cover or bring mechanical force to the ventilation membrane on the back of the unit.

If the unit is not working properly, contact the place of purchase, nearest Westermo distributor office or Westermo Tech support.

Maintenance

No maintenance is required, as long as the unit is used as intended within the specified conditions.

Product disposal.



This symbol means that the product shall not be treated as unsorted municipal waste when disposing of it. It needs to be handed over to an applicable collection point for recycling electrical and electronic equipment.

By ensuring this product is disposed of correctly, you will help to reduce hazardous substances and prevent potential negative consequences to both environment and human health, which could be caused by inappropriate disposal.

Simplified EU declaration of conformity

Hereby, Westermo declares that the equipment is in compliance with applicable EU directives. The full EU declaration of conformity and other detailed information are available at the respective product page at www.westermo.com.

Agency approvals and standards compliance

Type	Approval / Compliance
EMC	EN 61000-6-1, Immunity residential environments
	EN 61000-6-2, Immunity industrial environments
	EN 61000-6-3, Emission residential environments
	EN 61000-6-4, Emission industrial environments
	EN 50121-3-2, Railway applications - EMC: Rolling stock – Apparatus
	EN 50121-4, Railway signalling and telecommunications apparatus
	IEC 62236-4, Railway signalling and telecommunications apparatus
Safety	EN 60950-1, IT equipment
Environmental	EN 50155 Railway applications - Electronic equipment used on rolling stock
Fire protection	EN 45545-2, Fire protection on railway vehicles

FCC Part 15.105 Notice:

This equipment has been tested and found to comply with the limits for a Class B digital device, pursuant to Part 15 of the FCC Rules. These limits are designed to provide reasonable protection against harmful interference in a residential installation. This equipment generates, uses and can radiate radio frequency energy and, if not installed and used in accordance with the instructions, may cause harmful interference to radio communications. However, there is no guarantee that interference will not occur in a particular installation. If this equipment does cause harmful interference to radio or television reception, which can be determined by turning the equipment off and on, the user is encouraged to try to correct the interference by one or more of the following measures:

- ⌘ Reorient or relocate the receiving antenna
- ⌘ Increase the separation between the equipment and receiver
- ⌘ Connect the equipment into an outlet on a circuit different from that to which the receiver is connected
- ⌘ Consult the dealer or an experienced radio/TV technician for help.

Type tests and environmental conditions

Phenomena	Test	Description	Test levels
ESD	EN 61000-4-2	Enclosure contact	± 6 kV (crit A)
		Enclosure air	± 8 kV (crit A)
RF field AM modulated	IEC 61000-4-3	Enclosure	20 V/m 80% AM (1 kHz), 80 – 2500 MHz (crit A)
Fast transient	EN 61000-4-4	Ethernet ports	± 2 kV (crit A)
		Earth port	± 2 kV (crit A)
Surge	EN 61000-4-5	Fault port	± 2 kV line to earth (crit A)
		Ethernet ports	± 2 kV line to earth (crit A)
		Power port	± 2 kV line to earth, ± 2 kV line to line (crit A)
RF conducted	EN 61000-4-6	Ethernet ports	10 V 80% AM (1 kHz), 0.15 – 80 MHz (crit A)
		Power port	10 V 80% AM (1 kHz), 0.15 – 80 MHz (crit A)
Power frequency magnetic field	EN 61000-4-8	Enclosure	1000 A/m 50 Hz 300 A/m 16.7 Hz, 60 Hz, DC (crit A)
Pulse magnetic field	EN 61000-4-9	Enclosure	300 A/m (crit A)
Voltage dips and interruption	EN 50155	DC power ports	10 ms interruption, 100 ms ±40% voltage variation
Radiated emission	CISPR 16-2-3 ANSI C63.4 (FCC part 15)	Enclosure	Class B (30 – 6000 MHz)
Conducted emission	CISPR 16-2-1	DC power port & Ethernet ports	Class B
Dielectric strength	EN 50155	Ethernet ports to other isolated ports	707VDC 1 min
		Power & Fault port to other isolated ports	2121 VDC 1 min
Temperature	EN 60068-2-1 EN 60068-2-2	Operating	-40 to +70°C
		Storage & Transport	-40 to +70°C
Humidity	EN 60068-2-30	Operating	5 to 95% relative humidity
		Storage & Transport	5 to 95% relative humidity
Altitude		Operating	2000 m / 70 kPa
Reliability prediction (MTBF)	MIL-C217F2	Operating	Ground Benign: 150 years @ 20 °C 147 years @ 40 °C 135 years @ 60 °C Ground Mobile: 9,87 years @ 20 °C 9,85 years @ 40 °C 9,79 years @ 60 °C Ground Fix: 28,54 years @ 20 °C 28,43 years @ 40 °C 27,95 years @ 60 °C
Service life		Operating	10 year
Vibration, random simulated long life	IEC 60068-2-64, Cat. 1 class B (EN 61373)	Not Operating	Vertical: 7.9 m/s ² Transverse: 7.9 m/s ² Longitudinal: 7.9 m/s ² 3 x 5 h
Vibration, random functional	IEC 60068-2-64, Cat. 1 class B (EN 61373)	Operating	Vertical: 1.0 m/s ² Transverse: 1.0 m/s ² Longitudinal: 1.0 m/s ² 3 x 10 min

Phenomena	Test	Description	Test levels
Shock, half sine pulses	IEC 60068-2-27, Cat. 1 class B (EN 61373)	Operating	Vertical: 50 m/s ² Transverse: 50 m/s ² Longitudinal: 50 m/s ² 30 ms, 3 x 6 shocks
Shock, sawtooth	IEC 60068-2-27, Cat. 1 class B (IEEE1478-2001)	Operating	Vertical: 100 m/s ² Transverse: 100 m/s ² Longitudinal: 100 m/s ² 11 ms, 3 x 6 shocks
Enclosure	UL 94	Nickel coated zinc	Flammability class V-1
Dimension W x H x D			175 x 100 x 53,4 mm
Weight			0.9 kg
Degree of protection	IEC 529	Enclosure	IP 65 when all ports are protected/ connected else IP 40
Cooling			Convection
Mounting			DIN Rail or wall mounted

Description

Functional description

Viper 008 is a unmanaged switch developed for rail and industrial applications. To meet the environmental requirements from rail and harsh industrial applications the switch has rugged M12 Ethernet connectors and full metal housing. The IP65 sealed metal case make it robust and allows for the surrounding air temperature to be between -40 to $+70^{\circ}\text{C}$. There are no sensitive or fragile components, hardening the product against shock and vibration making these units suitable for rolling stock usage. The power supply operates over a wide input range from 24 to 110 VDC.

Interface specifications

Power and fault relay port PWR	
Rated voltage	24 to 110 VDC
Operating voltage	16.8 to 143 VDC (14.4 to 154 VDC for 100 ms)
Rated current	110 mA @ 24 VDC 33 mA @ 110 VDC
Rated frequency	DC
Inrush current, I^2t	Max 0.02 A ² s @ 24 – 110 VDC
Polarity	Reverse polarity protected
Startup current*	300 mA @ 16.8 VDC
Redundant power input	No
Isolation to	Connections X1 – X8 and to ground, 1500 VAC. Fault relay belongs to the same isolation group as the power supply lines (fault relay signals are also contained within PWR).
Connection	4 pin male M12 connector with A-code
Connector size	M12, recommended cable area 0.5 mm ² recommended (minimum 0.25 mm ²), cable dimensions depend on choice of M12 connector
Shielded cable	Not required, twisted pair is recommended
Fault relay resistance	< 10 Ω

* If external power supply is used it must meet specified startup current.

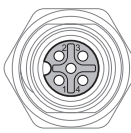
 M12 A-Coded Power Connector	Position	Direction	Description
	1	U+	Positive supply voltage
	2	Out	Alarm relay (status) +
	3	0V	Negative supply voltage
	4	Out	Alarm relay (status) –
	Housing	Shield	Chassis of product (ground)

Fault Contact

The Viper switch is equipped with a potential free normally closed fault contact. The fault contact is a solid state component (relay) that requires power to work and it is transient protected. Additionally, the fault contact is opened when any of the following conditions is met:

- No voltage on the power supply pin, a voltage level outside the legal voltage range or current limitation on the voltage source is applied on the power input.

Description of how connection to the fault contact could be done is shown below. The relay is closed when the unit is OK and open at failure. The relay is of semiconductor type (no moving parts). It is specified for max current 250 mA continuous, 500 mA peak (10 ms), operational voltage up to 110 V, protected by a 150 VDC-varistor, ON-resistance less than 10 Ohm, and leakage current max 1 μ A.

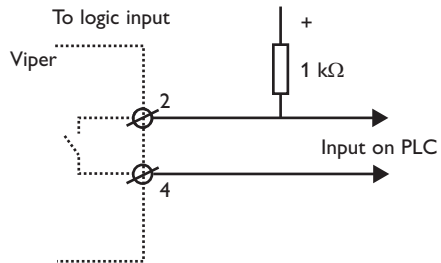
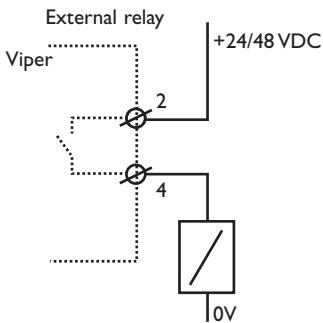

Service port

The Service Port should not be used by non other than the Westermo Technical Support team. Do not connect any device or cable to the Service Port.

Ethernet TX port X1 to X8	
Electrical specification	IEEE std 802.3. 2005 Edition
Data rate	10 Mbit/s or 100 Mbit/s
Duplex	Full or half
Circuit type	TNV-1
Transmission range	100 m
Isolation to	Other Ethernet ports, 500 VAC PWR, 1500 VAC
Galvanic connection to	None, except for shielded contact to housing
Connection	4-pole M12 female with D-code
Shielded cable	Not required, twisted pair is recommended
Conductive housing	Nickel plated zinc, metal housings of X1-X8 also connected to the housing
Number of ports	8 Ethernet (X1-X8)

	Position	Direction	Description
	1	Out	Transmit Data +
	2	In	Receive Data +
	3	Out	Transmit Data –
	4	In	Receive Data –
Housing	Shield	Chassis of product (ground)	

Location of Interface ports, LED's

LED indicators

LED	Status	Description
PWR	GREEN	Unit indicates no fault
	RED	Unit indicated fault
X1 to X8	OFF	No Link
	GREEN	Link is up
	GREEN FLASH	Data is transmitted

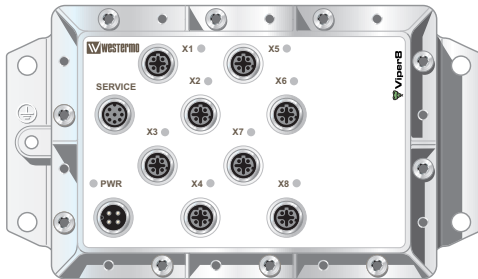

Mounting, DIN-rail

This unit can be mounted on 35 mm DIN-rail, which is horizontally mounted inside an apparatus cabinet or similar. Snap on mounting, see figure.

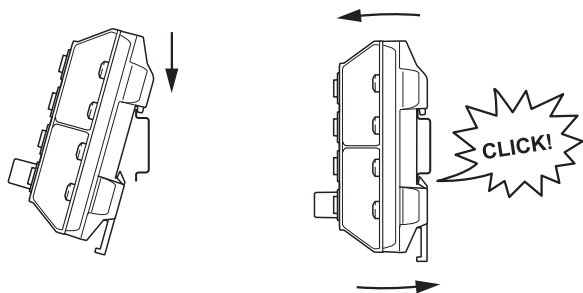

Removal

Press down the support at the back of the unit using a screwdriver. See figure.

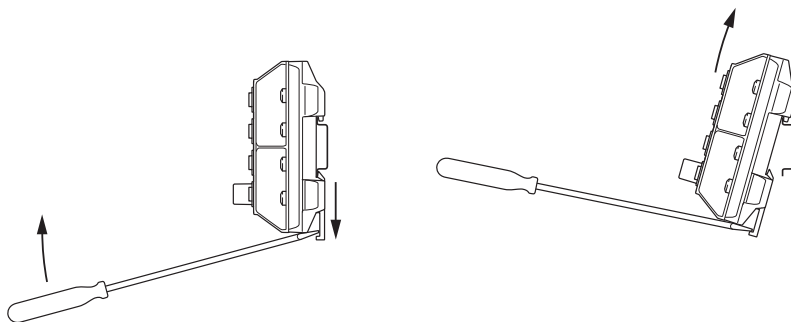

Wall mounting

There are four 6 mm bore holes intended for mounting the unit. The unit can be mounted vertical or horizontal. Use four M6 screws with 12 mm washer on a flat and stable surface.

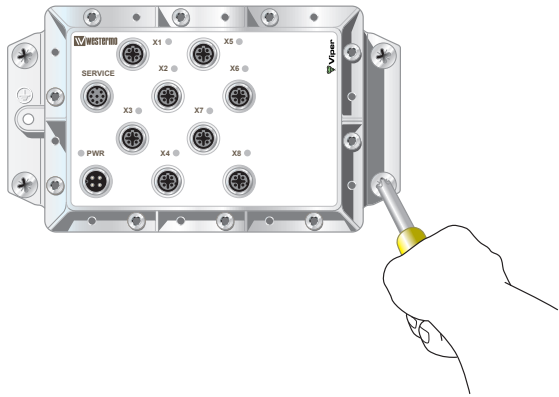

Removal

Disconnect all cables and unscrew the unit from the wall.

Cooling

This unit uses convection cooling. Avoid obstructing the airflow around the unit. Spacing is recommended for the use of unit in full operating temperature range and service life.

Dimensions

Measurements are stated in millimeters.

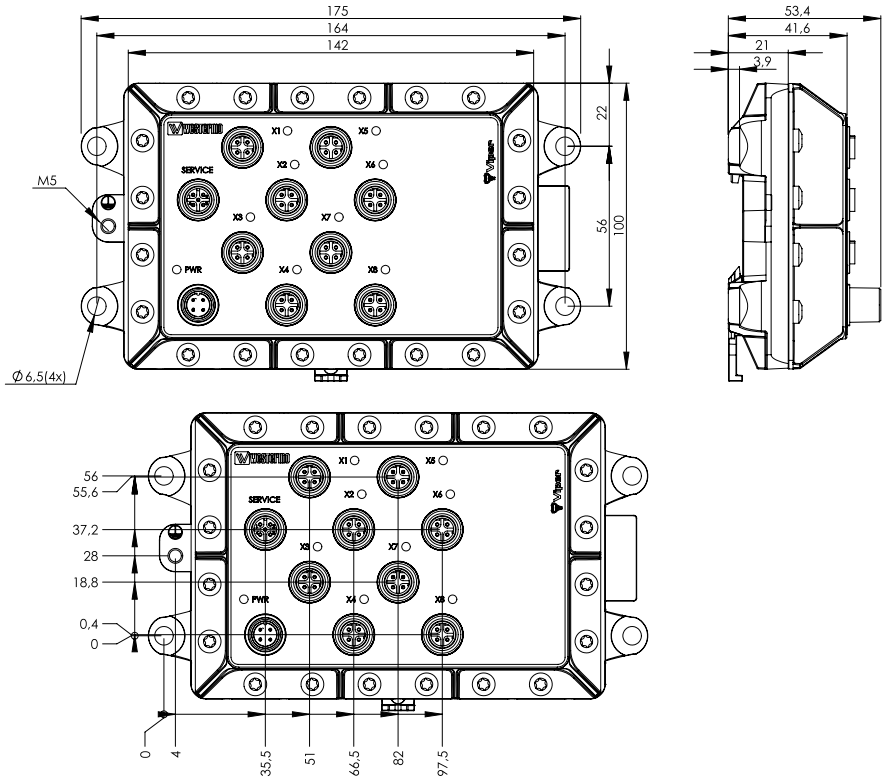



Westermo • SE-640 40 Stora Sundby, Sweden
Tel +46 16 42 80 00 Fax +46 16 42 80 01
E-mail: info@westermo.com
www.westermo.com