

# RT-370

## User Guide



## Version History

Version	Date	Comments
A	2018-03	First version
B	2018-05	Table 1 Fiber optic ETH specification updated

### License and copyright for included Free/Libre Open Source Software

This product includes software developed by third parties, including Free/Libre Open Source Software (FLOSS). The specific license terms and copyright associated with the software are included in each software package respectively. Please visit the product homepage for more information.

Upon request, the applicable source code will be provided. A nominal fee may be charged to cover shipping and media. Please direct any source code request to your normal sales or support channel.

## Table of Contents

<b>1 Foreword</b> .....	<b>5</b>
1.1 References .....	5
1.2 Abbreviations and Terms.....	5
<b>2 RT-370 Introduction</b> .....	<b>6</b>
2.1 Supported Product Versions, Variants and SW .....	7
2.2 Important Safety Notes.....	7
2.3 Delivery Content .....	8
2.4 Installation Countries.....	8
2.5 Regulatory Notices .....	9
2.5.1 United States (FCC) .....	9
2.5.2 Canada (IC).....	9
2.5.3 Certified Antennas for FCC and IC .....	10
2.6 Output power limitations.....	10
2.7 RT-370 Identification and Version Information.....	11
<b>3 Technical Features</b> .....	<b>13</b>
<b>4 Installation</b> .....	<b>13</b>
4.1 Installation Procedure, Overview.....	13
4.2 Dimensions for Fixing Points.....	14
4.2.1 Mechanical Overview .....	14
4.2.2 Mechanical Integration, Fixing Points and Connector Positions .....	16
4.3 Considerations When Mounting the Device .....	17
4.3.1 Typical Power Consumption.....	17
4.3.2 Temperature Alarms.....	17
4.3.3 General Installation Considerations .....	17
4.3.4 Outdoor Installation with Sun Load .....	17
4.3.5 Ambient Operating Temperature Range .....	17
4.3.6 Installations at Very High Temperatures .....	18
4.4 Connecting the System Grounding .....	20
4.5 Connecting the RF Antenna Interfaces .....	21
4.5.1 RF Antenna Interface Operation Modes .....	21
4.5.2 Monitoring Antenna RF Connector.....	22
4.5.3 Communication Antenna RF Connectors.....	23
4.6 Connecting the Fiber Optical Cable .....	23
4.7 Connecting the AC Power Feed.....	25
4.7.1 Power Consumption Examples .....	27
<b>5 Outdoor Radio Access Point Configuration and Use</b> .....	<b>29</b>
5.1 LED Indicators During Power Up Sequence .....	29
5.2 Connecting the service Ethernet .....	29
5.2.1 Service Ethernet Port Features .....	30
5.3 RT-370 Factory Reset Interface, Process for Factory Reset .....	31
5.3.1 Factory Reset Adapter Specification.....	31
5.3.2 Factory Reset Procedure .....	32
<b>6 Maintenance</b> .....	<b>33</b>
6.1 Cleaning– Resistance to Chemicals.....	33
6.2 Troubleshooting Based on Functional Behavior .....	34
6.3 Repair Work.....	34
6.3.1 Product Exchange .....	34

## Figures and Tables

Figure 1 RT-370.....	6
Figure 2 RT-370 Block diagram.....	6
Figure 3 Product identification label position.....	11
Figure 4 Product identification label example.....	11
Figure 5 Product label example.....	12
Figure 6 RT-370 Mechanical overview.....	14
Figure 7 RT-370 connectors.....	16
Figure 8 Installation with blocked airflow shall be avoided.....	18
Figure 9 Installation with free airflow – good installation.....	18
Figure 10 Improved heat transfer based on fixing plate.....	19
Figure 11 The grounding screw.....	20
Figure 12 Monitoring antenna interface.....	22
Figure 13 Communication antenna interfaces.....	23
Figure 14 Fiber optic ETH interface.....	23
Figure 15 AC interface.....	25
Figure 16 Power, operation, failure and FO Ethernet interface LEDs.....	29
Figure 17 Service 1000Base-TX interface.....	30
Figure 18 Factory reset plug X-coded.....	31
Table 1 Supported product versions, variants and SW.....	7
Table 2 Important safety notes.....	7
Table 3 Delivery content.....	8
Table 4 Installation countries.....	8
Table 5: FCC and IC certified antennas.....	10
Table 6: Output power limitations.....	10
Table 7 Product identification.....	11
Table 8 Product label information.....	12
Table 9 Installation procedure.....	13
Table 10 Dimensions and weight.....	15
Table 11 Fixing points and connector positions.....	16
Table 12 Installation procedure, fixing the protective earth.....	20
Table 13 Pinning: RF antenna connector.....	21
Table 14 RF Antenna interface operation.....	21
Table 15 Pinning: Fiber optic ETH connector.....	23
Table 16 Fiber optic ETH specification.....	24
Table 17 Installation procedure, installing fiber optical cable.....	24
Table 18 Pinning: AC Mains Connector.....	25
Table 19 Installation Procedure, Installing AC Cable.....	25
Table 20 Power feed specification.....	26
Table 21: 2.4 GHz power consumption with 100 VAC.....	27
Table 22: 2.4 GHz power consumption with 230 VAC.....	27
Table 23: 5 GHz power consumption with 100 VAC.....	28
Table 24: 5 GHz power consumption with 230 VAC.....	28
Table 25 Service 1000Base-TX Connector.....	30
Table 26 4.6.1 Ethernet port features.....	30
Table 27 Factory reset procedure.....	32
Table 28 Exchange flow.....	34

# 1 Foreword

This document describes the Installation procedure of the RT-370 device.

## 1.1 References

No.	Title
[1]	Software Management Guide
[2]	RT-370 Datasheet

## 1.2 Abbreviations and Terms

Abbreviation	Description
AP	Access Point
BSSID	Basic Service Set ID
EMC	Electro Magnetic Compatibility
ETH	Ethernet
FAI	First Article Inspection
FO	Fiber Optic
GW	Gateway
HTTP	Hyper Text Transfer Protocol
IC	Industry Canada
ID	Identification
IP	Internet Protocol
LED	Light Emitting Diode
MAC	Media Access Control
MMI	Man-Machine Interface
ODC-2	Fiber Optical Outdoor Connector from Huber & Suhner (H&S)
OD RAP	Outdoor Radio Access Point
PE	Protective Earth
RSSI	Receive Signal Strength Indicator
RX	Receive
SN	Serial Number
SNMP	Simple Network Management Protocol
STA	Station
TRE	Trackside Radio Equipment
TX	Transmit
WLAN	Wireless Local Area Network

## 2 RT-370 Introduction

The RT-370 is a wireless communication product, developed for demanding industrial and railway applications.

It is a radio device operating at 2.4 and 5 GHz WLAN bands, and can be configured as Access Point.

The Westermo configuration management tool, WeConfig, can be used for discovery and basic configuration and maintenance. The configuration can be done via SNMP or via WebGUI. The status information is available in local LED status indicators, and through SNMP/WebGUI.



Figure 1 RT-370

The RT-370 functional block diagram is shown in Figure 2.

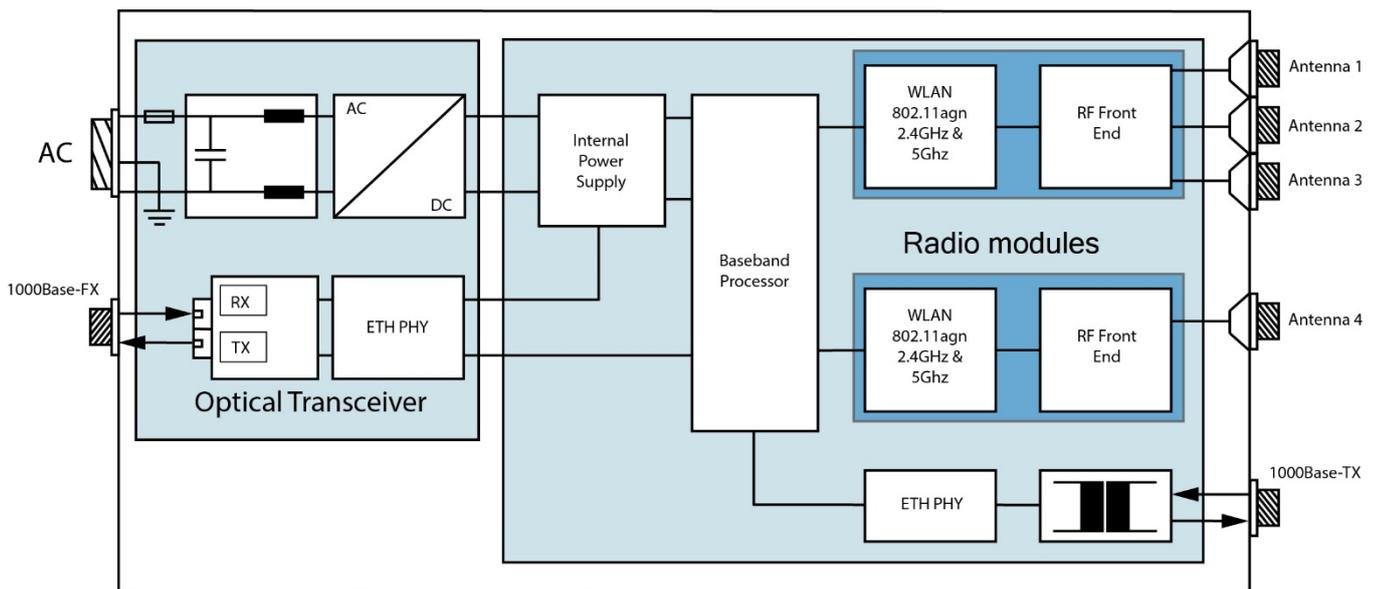


Figure 2 RT-370 Block diagram

## 2.1 Supported Product Versions, Variants and SW

Supported product versions, variants and SW:

<i>Specification</i>	<i>Value</i>	<i>Notes</i>
<i>Product Versions/ Variants</i>	<i>RT-370</i>	
<i>Software Version</i>	<i>V6.6 and higher</i>	

Table 2 Supported product versions, variants and SW

## 2.2 Important Safety Notes

	<p><b>Notice</b></p> <p>The optical fast Ethernet interface of this device uses a class 1 laser product. It complies with EN 60825-1 and FDA 21 CFR 1040.10 and 1040.11</p> <p>The laser is eye-safe under all operating conditions.</p>
	<p><b>Danger!</b></p> <p>Do not use damaged equipment and/or accessories such as damaged power cord.</p>
	<p><b>Danger!</b></p> <p>Never try to open the device. There are no serviceable parts inside! By trying to open the device you will be exposed to a risk of death or injury.</p>
	<p><b>Warning!</b></p> <p>Product warranty gets void and any liability will be disclaimed when opening the device.</p>
	<p><b>Warning!</b></p> <p>Read this user guide carefully before mounting, installing and operating the device.</p>
	<p><b>Warning!</b></p> <p>Never unplug equipment from the electrical outlet by holding the cord only, always disconnect the cable by applying force directly to the plug.</p>
	<p><b>Warning!</b></p> <p>Do not operate the device in any other environmental conditions than it is designed for.</p>

Table 3 Important safety notes

## 2.3 Delivery Content

The delivery consists of following main components:

<b>Description</b>	<b>Number of Parts</b>	<b>Notes</b>
<b>RT-370</b>	<b>1</b>	
<b>Connector Dust Cap</b>	<b>6</b>	<i>Temporary protection of connectors:</i> <ul style="list-style-type: none"> <li>- 1 plastic cap for FO connector</li> <li>- 1 plastic cap for ETH connector</li> <li>- 4 plastic caps for antenna connectors</li> </ul>

**Table 4 Delivery content**

## 2.4 Installation Countries

Installation country regulatory limits and operating parameters are controlled by Software Country Code parameter.

This product supports:

<b>Country Code</b>	<b>Operating Frequency Ranges</b>	<b>Notes</b>
<b>Europe (EU)</b>	<b>2412 ... 2472 MHz and 5180 ... 5320 MHz, 5500 ... 5700 MHz</b>	<i>Operation according to ETSI limitations For detailed specification, refer to document [1]</i>
<b>United States (USA)</b>	<b>2412 ... 2472 MHz and 5180 ... 5320 MHz, 5500 ... 5700 MHz 5725 ... 5850 MHz</b>	<i>Operation according to FCC limitations For detailed specification, refer to document [1]</i>
<b>Canada (CANADA)</b>	<b>2412 ... 2472 MHz and 5180 ... 5320 MHz, 5500 ... 5700 MHz 5725 ... 5850 MHz</b>	<i>Operation according to IC limitations For detailed specification, refer to document [1]</i>

**Table 5 Installation countries**

**Note:** Further Software releases might support additional country codes, for up-to-date country code specification refer to document [1]

## 2.5 Regulatory Notices

### Caution!

Any changes or modifications shall be approved by the party responsible for compliance. If not, users could void the user's authority to operate the equipment.

Country code and antenna gain needs to be set properly for correct functionality in the installed country.

### 2.5.1 United States (FCC)

The enclosed device complies with Part 15 of the FCC Rules. Operation is subject to the following two conditions: (i.) this device may not cause harmful interference and (ii.) this device must accept any interference received, including interference that may cause undesired operation.

Contains FCC ID: **2AEJD-103902-DT50RF**

#### RF Exposure requirements:

To satisfy FCC RF exposure requirements for mobile transmitting devices, a separation distance of 20 cm or more should be maintained between the antenna of this device and persons during operation. To ensure compliance, operations at closer distances than this are not recommended.

#### Antennas:

The device can operate with the antennas listed in 2.5.3.

### 2.5.2 Canada (IC)

This device complies with Industry Canada's licence-exempt RSSs. Operation is subject to the following two conditions:

1. This device may not cause interference.
2. This device must accept any interference, including interference that may cause undesired operation of the device.

Le présent appareil est conforme aux CNR d'Industrie Canada applicables aux appareils radio exempts de licence. L'exploitation est autorisée aux deux conditions suivantes:

1. l'appareil ne doit pas produire de brouillage.
2. l'utilisateur de l'appareil doit accepter tout brouillage radioélectrique subi, même si le brouillage est susceptible d'en compromettre le fonctionnement.

IC Certification Number of the implemented WLAN communication module: **9301A-103902DT50**

#### Antennas:

The device can operate with the antennas listed in 2.5.3.

### 2.5.3 Certified Antennas for FCC and IC

The following antennas can be used with the device (the antenna type ID has to be set to the right value):

<i>Type</i>	<i>Part number</i>	<i>Manufacturer</i>	<i>Gain</i>	<i>Chains</i>	<i>Antenna Type ID</i>
Dipole	F51-N	Tekfun	2 GHz: 4.5 dBi max 5 GHz: 7 dBi max	1, 2, 3	04
Patch	SPA 2400/75/8/0/V	Huber & Suhner	2 GHz: 7.5 dBi max	1, 2, 3	05
Patch	SPA-5600/40/14/0/V_2	Huber & Suhner	5 GHz: 14 dBi max	1, 2	06
Patch	SPA-5600/65/9/0/ MIMO	Huber & Suhner	5 GHz: 9 dBi max	1, 2, 3	07
Shark	SPA-5600/45/12/10/V	Huber & Suhner	5 GHz: 12 dBi max	1, 2	08

**Table 6: FCC and IC certified antennas**

## 2.6 Output power limitations

The RT-370 has following output power limitations for ambient temperatures from -40°C to +70°C.

<b>Active antennas</b>	<b>Max. output power</b>
1	22 dBm per chain
2	22 dBm per chain
3	22 dBm per chain

**Table 7: Output power limitations**

## 2.7 RT-370 Identification and Version Information

Product identification information is available at the product label. The product label is fixed to the device.



Figure 3 Product identification label position

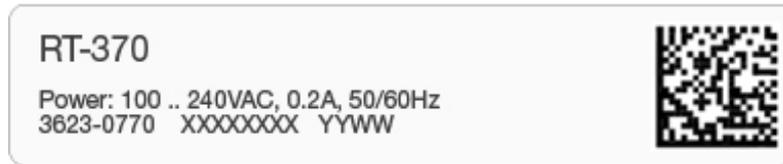


Figure 4 Product identification label example

Specification	Value	Notes
<b>Product Name</b>	<b>RT-370</b>	
<b>Part Number</b>	<b>3623-0770</b>	
<b>SN</b>	<b>XXXXXXXX</b>	<i>Internal serial number</i>
<b>Manufacturing Date</b>	<b>YYWW</b>	<i>The date format is: YY = manufacturing year WW = manufacturing week</i>
<b>BAR CODE</b>	<b>SN information</b>	<i>Data matrix</i>
<b>Hot surfaces</b>		<i>Surface temperature can be above 60°C</i>

Table 8 Product identification

At the rear side of the product further product specific information is printed to a second label.

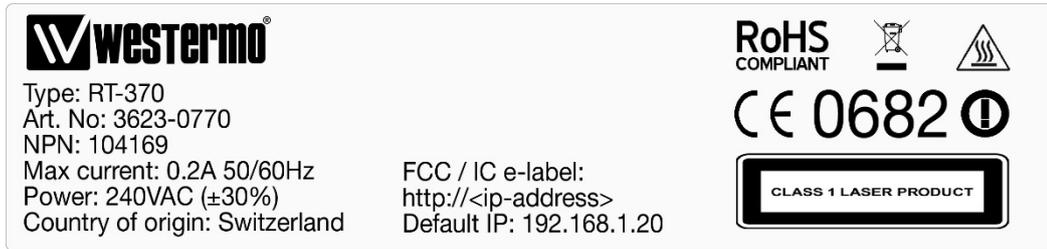


Figure 5 Product label example

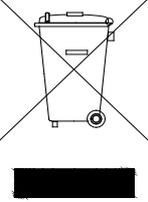
Specification	Value	Notes
<b>Product Name</b>	<b>RT-370</b>	
<b>Part Number</b>	<b>3623-0770</b>	
<b>Max current</b>	<b>0.2 A</b>	<i>Information on input current</i>
<b>Power</b>		<i>Information on input power feed</i>
<b>WEEE</b>		<i>This symbol, found on the product indicates that this product should not be treated as household waste when disposing of it. Instead it must be handled over to an applicable collection point for the recycling of electrical and electronic equipment. By ensuring this product is disposed correctly, you will help prevent potential negative consequences to the environment and human health, which could be otherwise be caused by inappropriate disposal of this product.</i>
<b>CE</b>		<i>CE mark</i>
<b>Notified body</b>	<b>0682</b>	<i>Identification number of the notified body Cetecom ICT Services GmbH Germany</i>
<b>R&amp;TTE directive</b>		<i>Class 2 radio equipment for which restrictions apply to putting into service.</i>
<b>Hot surfaces</b>		<i>Surface temperature can be above 60°C.</i>
<b>FCC / IC e-label</b>	FCC / IC e-label: <a href="http://&lt;ip-address&gt;">http://&lt;ip-address&gt;</a> Default IP: 192.168.1.20	<i>Link to the FCC / IC e-label</i>

Table 9 Product label information

## 3 Technical Features

Technical features are described in the reference document [2].

## 4 Installation

### 4.1 Installation Procedure, Overview

<i>Order of Installation Step</i>	<i>Description</i>
<b>1. Fixing</b>	The product is fixed in operating environment, ensuring that the environment complies with the installation environment constrains. See chapter 4.2
<b>2. System Grounding</b>	The system grounding is ensured and verified based on customer installation. See chapter 4.4
<b>3. Antennas</b>	The antenna interfaces are installed based on customer requirements. See chapter 4.5
<b>4. Ethernet</b>	The Ethernet data interface is installed. See chapter 4.6
<b>5. Power Feed</b>	Power feed cable is connected (the power may be already activated in the cable), the power supply is switched on and verify that the LED indicators shows correct power up procedure. See chapter 0
<b>6. Configuration</b>	The configuration process is described in reference document [1] chapter: Configuration.

**Table 10** Installation procedure

## 4.2 Dimensions for Fixing Points

### 4.2.1 Mechanical Overview

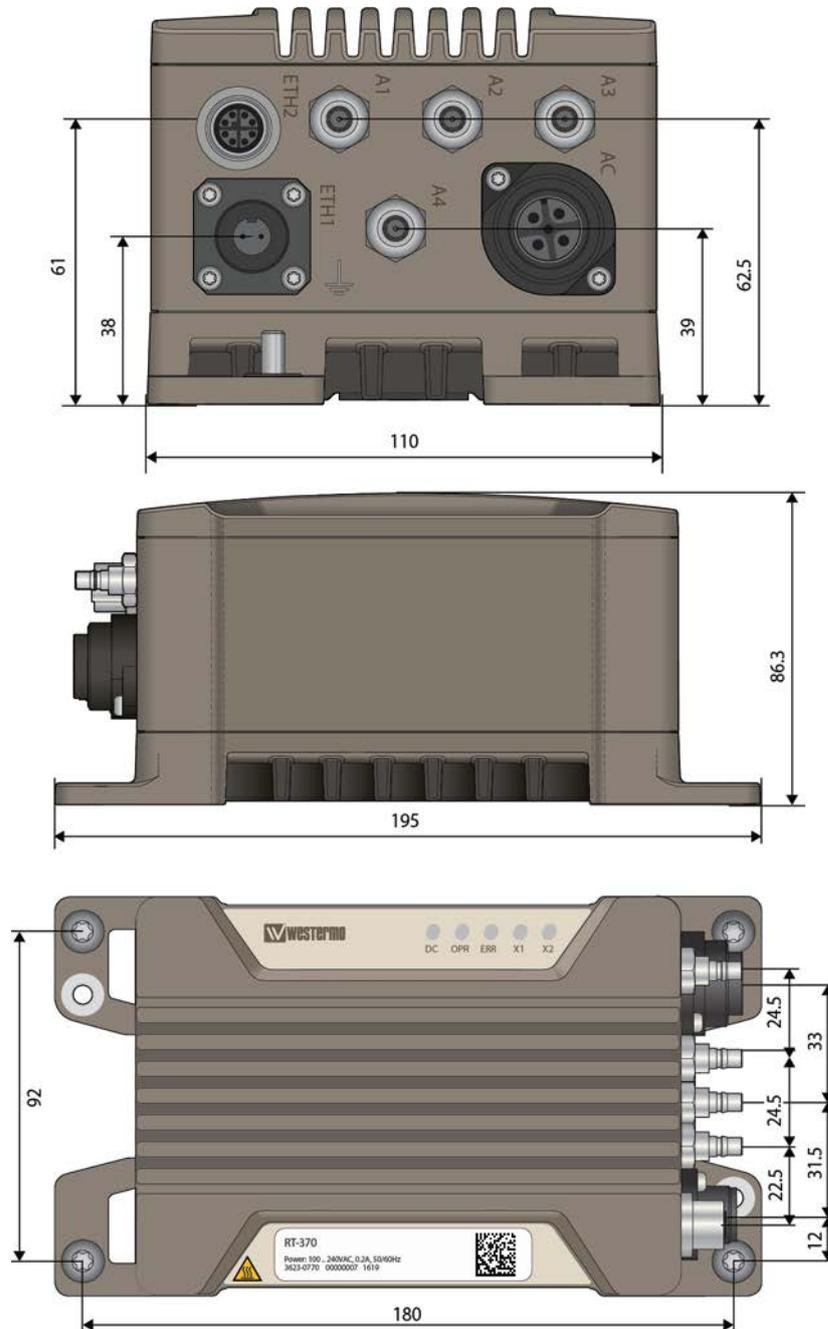


Figure 6 RT-370 Mechanical overview

<b>Parameter</b>	<b>Value</b>	<b>Notes</b>
<b>Maximum dimensions</b>	195 x 110 x 86.3 mm	Without cables
<b>Maximum dimensions, with cables but not including antennas</b>	App 320 x 110 x 87 mm	Space needed for installation
<b>Clearance</b>	300 mm	For cabling
<b>Location of the fixing points</b>	In each corner	With four M6 screws
<b>Color</b>	RAL 7006, beige grey	Powder coating
<b>Protection</b>	IP66	
<b>Weight</b>	1.75 kg	

Table 11 Dimensions and weight

### 4.2.2 Mechanical Integration, Fixing Points and Connector Positions

The product must be fixed with the four fixing points located at the corners of the product. M6 screws shall be used for the fixation of the product. The screws shall be tightened with min. 3.0Nm (fixing screw ISO 898/1, quality class 8.8).

**NOTICE:** All four specified fixing points must be used for fixing. The fixing surface should be flat to have all fixing points connected to the surface.

The product has a membrane vent at the bottom of the product for equalizing pressure changes.

**NOTICE:** The vent does not require any maintenance. Any manipulations at the vent are not allowed.

Specification	Value					
Fixing holes positions	Fixing holes without threads, for 6 mm screws: four pieces of slot holes, see: Figure 6					
	0 mm, 92 mm			180 mm, 92 mm		
	0 mm, 0 mm			180 mm, 0 mm		
RT-370 fixing screws	M6 screws/ 6 mm screw, screw length to be selected by installer based on installation environment and device weight					
Clearance	Slot holes require a clearance of min. 10 mm at the long side of the RT-370 for correct installation and removal. Clearance for heat transfer is to be considered separately.					
Connector positions	AC POWER	Antenna 1	Antenna 2	Antenna 3	100Base-FX FO ETH	100Base-TX ETH
	See Figure 7 Figure 15	See Figure 7 Figure 13	See Figure 7 Figure 13	See Figure 7 Figure 12	See Figure 7 Figure 14	See Figure 7 Figure 17
Grounding	See Table 12					

Table 12 Fixing points and connector positions

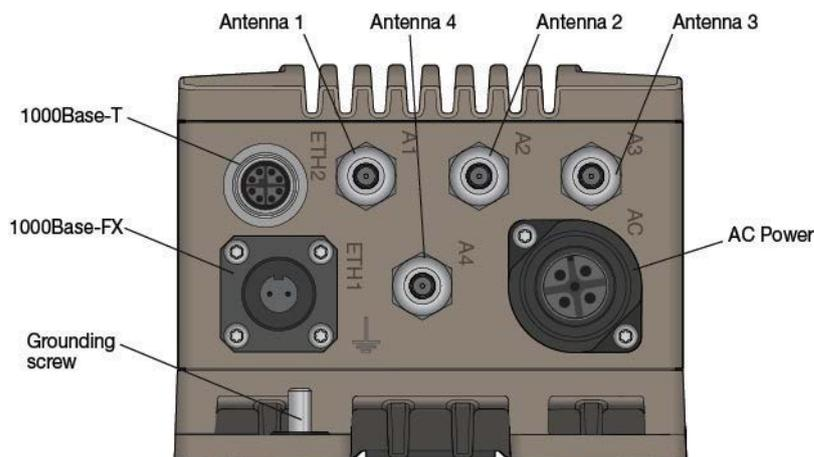


Figure 7 RT-370 connectors

## 4.3 Considerations When Mounting the Device

### 4.3.1 Typical Power Consumption

- For normal operation the power consumption is app. 10 W
- The power consumption for standby operation (sending beacons, no associated client) is app. 8.5 W

### 4.3.2 Temperature Alarms

The product has integrated temperature sensors for monitoring the internal device temperature. The limits for the sensors are set so, that operation without alarm is ensured for ambient temperatures as specified assuming correct installation.

### 4.3.3 General Installation Considerations

When planning an installation at least the following points shall be considered:

- Indoor: protecting for dust (to ensure heat dissipation), vandalism, animals (rats, birds etc)
- Outdoor: protecting for sun (to optimize ambient temperature range), dust, dirt, vandalism etc.

### 4.3.4 Outdoor Installation with Sun Load

For installation at places where the product would be exposed to direct sunshine, user must take care that the ambient temperature range is ensured under the sun load conditions. Direct sun load is heating the product and therefore limiting the max ambient temperature (assumed temperature rise due to 1000 W/m<sup>2</sup> sun load: 15°C). There are temperature alarms built in the product alarming for too high temperatures. For more details see SW User Guide.

A protective housing with the goal to block the sunshine could be implemented to protect the product from sun load. The protective housing still needs to ensure air circulation around the product.

### 4.3.5 Ambient Operating Temperature Range

The RT-370 includes a vent allowing controlled air exchange due to temperature changes. Humidity is blocked by the vent.

To ensure correct operation over the whole specified temperature range, certain aspects need to be considered.

The limits are defined for installations with free air flow in installation environment.

It shall be noted that in real environment:

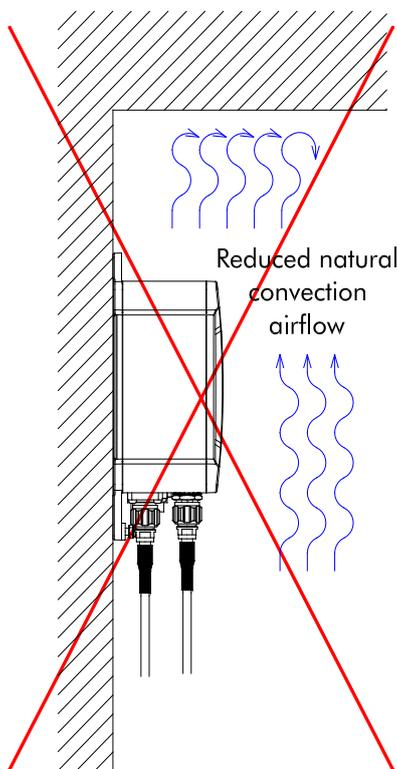
- Limited air flow is rising the device temperature and may lower the upper limit of the operating temperature range
- Conducted heat exchange through metal surfaces at the product fixing point is improving the device heat transfer and improving the operating conditions
- Temperature is dependent on operation parameters, like RF output power, amount of traffic
- RT-370 has internal temperature sensors that will issue alarms for too high or too low temperature. The operating conditions shall be ensured so that the normal operation does not cause temperature alarms. Any

temperature alarms shall be immediately rectified. See reference document [1] for detailed specification of the temperature sensors alarms.

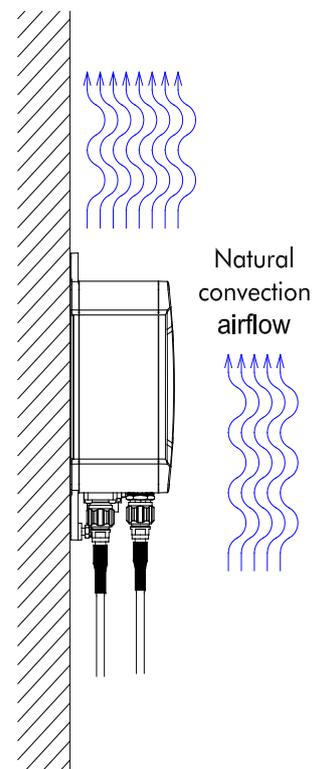
- The internal temperature alarms are adjusted so that the device supports the operating ambient temperatures for the nominal application scenario, i.e. considering typical power consumption of 7 W
- In real environment the power consumption will be slightly lower due to the fact that there are not always trains associated in the AP, typical real installation power consumption is in range 7..9 Watts

### 4.3.6 Installations at Very High Temperatures

For installations, where the product is operated close to its maximum specified ambient temperature ( $+55^{\circ}\text{C}$   $< T_{\text{Ambient}} < +70^{\circ}\text{C}$ ), it must be ensured that the natural convection is not blocked by objects nearby.

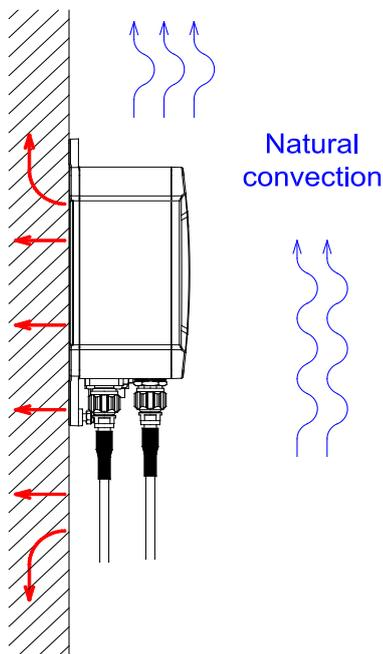


**Figure 8 Installation with blocked airflow shall be avoided**



**Figure 9 Installation with free airflow – good installation**

When operating at ambient temperatures above app. +60C it is recommended to mount the product to a metallic base plate to improve the heat dissipation. The base plate increases the surface to spread the heat.



**Figure 10 Improved heat transfer based on fixing plate**

## 4.4 Connecting the System Grounding

In the RT-370 construction, the housing is connected to the protective earth, signal ground. The RF antenna interfaces are referenced to the GND. The 1000BASE-TX Ethernet data interface is isolated.

There are two protective earth connection points, one at the AC connector and a second one at the grounding screw at the housing.

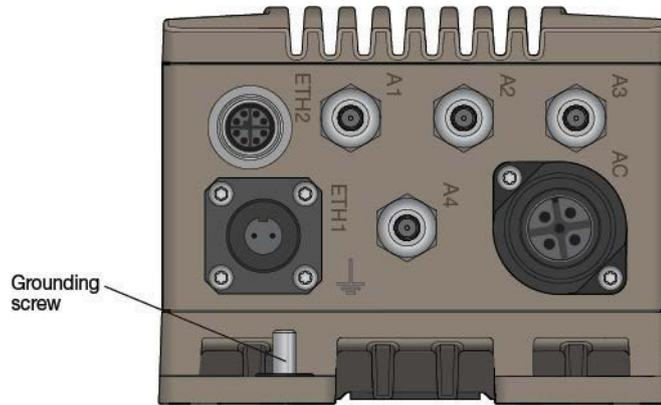


Figure 11 The grounding screw

***Important:*** For a safe operation and proper protection against lightning, both protective earth contacts of RT-370 must be connected to system ground. The grounding must be done always as a first step before connecting any other external interfaces to the product

For the grounding at the M5 stud, a wire with a cross section of at least 6.0 mm<sup>2</sup> shall be used.

<b><i>Order of Installation Step</i></b>	<b><i>Description</i></b>
<b><i>1. Open screw</i></b>	M5 nut must be opened until terminal of the protective earth can be placed at its place
<b><i>2. Install the wire</i></b>	The grounding wire is set below the rip-lock washer
<b><i>3. Fix the nut</i></b>	Tighten the nut for safe operation and good reliable grounding. The tightening torque shall be 2.0 Nm.

Table 13 Installation procedure, fixing the protective earth

## 4.5 Connecting the RF Antenna Interfaces

The antenna connectors are identified with the text markings A1 (Antenna 1), A2 (Antenna 2), A3 (Antenna 3) and A4 (Antenna 4). The product is delivered with temporary protecting caps that are removed for antenna cable installation.

The antenna interfaces are protected against lightning with special protection devices. To ensure correct operation of these devices it is important, that the earth grounding contact is connected to protective earth as described in chapter 4.4 with a short cable.

The antennas might be fixed in antenna connectors directly or using antenna cables fixed to the antenna connectors. The connectors should be secured to correct torque (typically 100Ncm, check connector manufacturer data), specially for assemblies in vibrating environments.

<i>Pin</i>	<i>Signal Name, Function</i>	<i>Notes</i>
<b>1</b>	Center pin: RF signal	Connector Type: N50 – Female
<b>2</b>	Connector body: RF ground	

**Table 14 Pinning: RF antenna connector**

### 4.5.1 RF Antenna Interface Operation Modes

RT-370 has four antenna interfaces. The antenna interfaces are operating independently of each other.

<i>Antenna Function</i>	<i>Operation</i>	<i>Notes</i>
<b>A1</b>	Antenna 1 is used for both transmitting and receiving	The antenna A1 shall be used.
<b>A2</b>	Antenna 2 is used for both transmitting and receiving	The antenna A2 can be enabled or disabled.
<b>A3</b>	Antenna 3 is used for both transmitting and receiving	The antenna A3 can be enabled or disabled.
<b>A4</b>	Antenna 4 is used for receiving	The antenna A4 can be enabled or disabled.

**Table 15 RF Antenna interface operation**

**NOTICE:** If only one of the communication antennas is used, the antenna port A1 **MUST** be used.

**NOTICE:** If one of the antennas is **NOT** used, the unused antenna conductors **MUST** be terminated with 50 ohm termination.

**NOTICE:** The antenna interfaces are protected against lightning with special protection devices. To ensure correct operation of these devices it is important, that the earth grounding contact is connected to protective earth as described in chapter 4.4.

### 4.5.2 Monitoring Antenna RF Connector

The antenna A4 is the antenna port used for monitoring of the RF spectrum. Connect the monitoring antenna to A4 port.

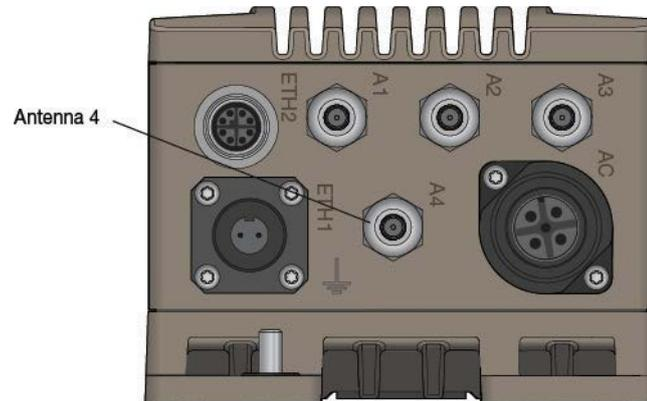
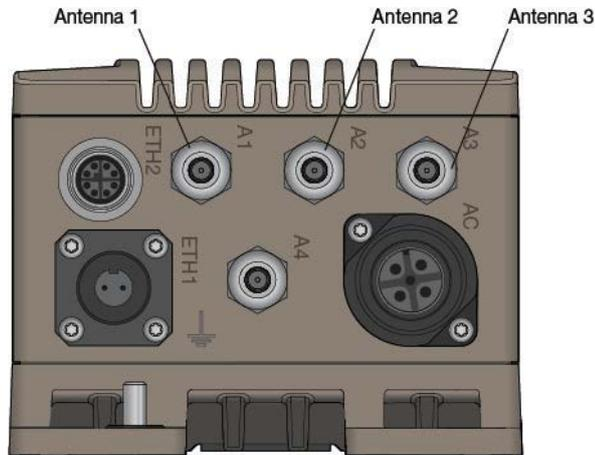


Figure 12 Monitoring antenna interface

### 4.5.3 Communication Antenna RF Connectors

The antenna interfaces A1, A2 and A3 are the antenna ports used for the communication link. Connect the antennas to those ports.



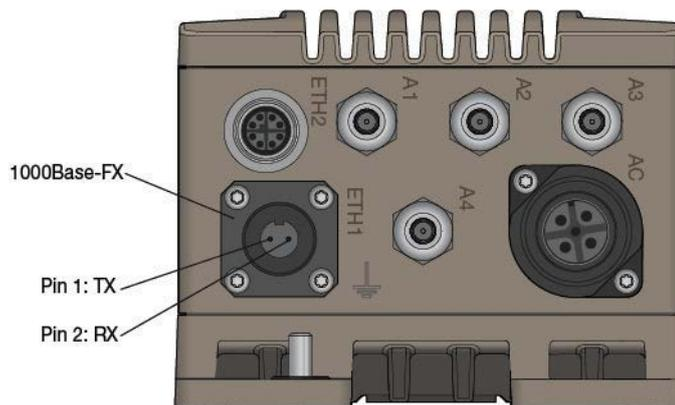
**Figure 13 Communication antenna interfaces**

**NOTICE:** If only one of the communication antennas is used, the antenna port A1 MUST be used. Otherwise the device is not operating correctly.

**NOTICE:** If one of the antennas is NOT used, the unused antenna connectors MUST be terminated with 50 ohm termination.

### 4.6 Connecting the Fiber Optical Cable

The fiber optical Ethernet interface is a 1310nm single mode optical interface. The optical connector is an ODC-2 type.



**Figure 14 Fiber optic ETH interface**

Pin	Signal Name, Function	Notes
1	TX (transmitting)	Connector Type: H&S ODC-2
2	RX (receiving)	

**Table 16 Pinning: Fiber optic ETH connector**

<b>Parameter</b>	<b>Value</b>	<b>Notes</b>
<b>Wavelength</b>	1310 nm	
<b>Transmit Power</b>	-9.5 dBm ... -3 dBm	
<b>Receiver Sensitivity</b>	-20 dBm or better	
<b>Receiver Saturation</b>	-3 dBm	<i>Optical attenuators need to be added to the installation if the optical level is above this limit</i>
<b>Network Standard</b>	1000Base-LX	
<b>Indicative Range</b>	10 km	

Table 17 Fiber optic ETH specification

<b>Order of Installation Step</b>	<b>Description</b>
<b>1. Remove dust cap</b>	Remove the temporary plastic dust cap installed at the ODC-2 plug. Do not remove the dust cap before installing the cable. The dust cap is used for transportation phase only, and shall be correctly disposed by installation person.
<b>2. Clean connector</b>	The optical interface and the fiber optic cable may need to be cleaned with isopropyl alcohol and a cleaning tissue.
<b>3. Install the cable</b>	Install the fiber optic cable to the connector. Use correct torque (typically 100 Ncm, check connector manufacturer data).

Table 18 Installation procedure, installing fiber optical cable

## 4.7 Connecting the AC Power Feed

The power feed is connected to the AC power feed connector.

**NOTICE:** The installation of the AC power must be done by trained professionals. It must be ensured that there is no power applied to the AC wires during the installation work.

**The Protective Earth must be connected before connecting the power feeds.**

**NOTICE:** When installing the product, it must be ensured that direct access to the AC plug is always possible and that the user is able to disconnect the AC plug to remove power from the device.

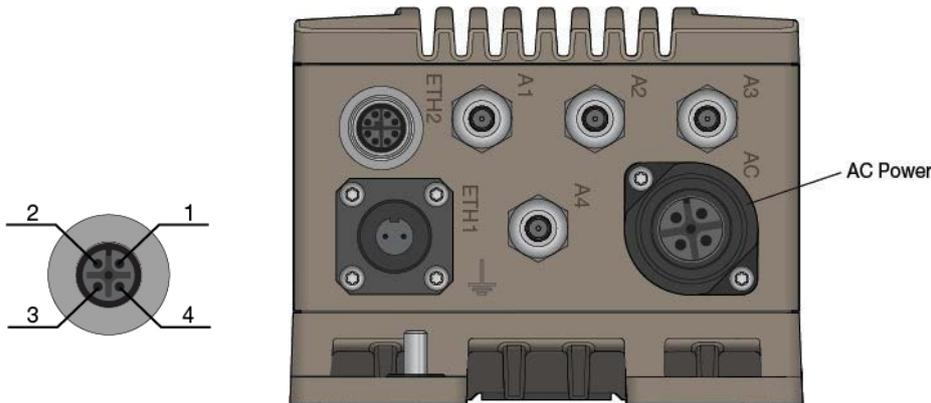


Figure 15 AC interface

Pin	Signal Name, Function	Notes
1	AC Phase	Connector Type: Binder 693 male socket 3+PE
2	AC Neutral	
3	-	
4	Protective Earth	

Table 19 Pinning: AC Mains Connector

Order of Installation Step	Description
1. Assembly of Binder connector	Assemble cable connector according pin out given above. Use ferrules and follow instructions of system integrator for reliable operation.
2. Install the cable	Install cable to the AC plug Use appr. 1.0 Nm tightening torque.

Table 20 Installation Procedure, Installing AC Cable

<b>Parameter</b>	<b>Value</b>	<b>Notes</b>
<b>Nominal voltage range</b>	100 V...240 V, 50/60 Hz	
<b>Min/max voltage range</b>	90..264 VAC	Guaranteed min/max operating voltage range
<b>Power consumption</b>	App. 8.5 W / 18.5 VA App. 10 W / 20.0 VA	Idle load Full load
<b>Peak value of inrush current</b>	34 A at 240 V	Inrush current shall be considered when e.g. selecting an external circuit breaker. The system integrator has to ensure that the devices are selected correctly. Duration and peak value of typical inrush currents are shown in the plot in the Annex
<b>Selecting external power connector and power cable diameter</b>	6...9.5 mm	External connector Binder 99-4222-00-04 shall be used for ensuring IP66
	10...12 mm	External connector Binder 99-4222-14-04 shall be used for ensuring IP66
<b>Allowed wire cross section</b>	0.5 – 2.5 mm <sup>2</sup>	
<b>Fuse</b>		To comply with EN 60950 the AC interface has a built in fuse. The fuse is not user replaceable! In case the fuse is broken the complete product must be sent to manufacturer for repair. The user is not allowed to open the device. By trying to open the device the user will be possessed to a risk of death of injury.

Table 21 Power feed specification

### 4.7.1 Power Consumption Examples

The power consumption is dependent on the operational parameters, like RF output power, amount of routed traffic and the RX duty cycle.

Test case	Antennas	TX duty cycle	TX output	Amb. Temp.	Avg. Power 100 VAC
2.4 GHz idle	1x1, 2x2, 3x3	2%	1...3 x 22 dBm	-40°C	P = 7.35 W/ 12.25 VA
2.4 GHz idle	1x1, 2x2, 3x3	2%	1...3 x 22 dBm	+70°C	P = 8.07 W/ 15.60 VA
2.4 GHz TX50 SISO, -40	1x1	50%	1 x 22 dBm	-40°C	P = 8.08 W/ 13.55 VA
2.4 GHz TX50 SISO +70	1x1	50%	1 x 22 dBm	+70°C	P = 8.75 W/ 17.13 VA
2.4 GHz TX50 2x2 MIMO -40	2x2	50%	2 x 22 dBm	-40°C	P = 9.08 W/ 15.39 VA
2.4 GHz TX50 2x2 MIMO +70	2x2	50%	2 x 22 dBm	+70°C	P = 9.80 W/ 19.30 VA
2.4 GHz TX50 3x3 MIMO -40	3x3	50%	3 x 22 dBm	-40°C	P = 10.08 W/ 17.23 VA
2.4 GHz TX50 3x3 MIMO +70	3x3	50%	3 x 22 dBm	+70°C	P = 10.85 W/ 21.47 VA
2.4 GHz TX90 SISO, -40	1x1	90%	1 x 22 dBm	-40°C	P = 8.97 W/ 15.17 VA
2.4 GHz TX90 SISO +70	1x1	90%	1 x 22 dBm	+70°C	P = 9.63 W/ 19.00 VA
2.4 GHz TX90 2x2 MIMO -40	2x2	90%	2 x 22 dBm	-40°C	P = 10.91 W/ 18.06 VA
2.4 GHz TX90 2x2 MIMO +70	2x2	90%	2 x 22 dBm	+70°C	P = 11.49 W/ 22.07 VA
2.4 GHz TX90 3x3 MIMO -40	3x3	90%	3 x 22 dBm	-40°C	P = 12.85 W/ 20.95 VA
2.4 GHz TX90 3x3 MIMO +70	3x3	90%	3 x 22 dBm	+70°C	P = 13.35 W/ 25.14 VA

**Table 22: 2.4 GHz power consumption with 100 VAC**

Test case	Antennas	TX duty cycle	TX output	Amb. Temp.	Avg. Power 100 VAC
2.4 GHz idle	1x1, 2x2, 3x3	2%	1...3 x 22 dBm	-40°C	P = 7.72 W/ 14.50 VA
2.4 GHz idle	1x1, 2x2, 3x3	2%	1...3 x 22 dBm	+70°C	P = 8.53 W/ 17.06 VA
2.4 GHz TX50 SISO, -40	1x1	50%	1 x 22 dBm	-40°C	P = 8.49 W/ 15.57 VA
2.4 GHz TX50 SISO +70	1x1	50%	1 x 22 dBm	+70°C	P = 9.12 W/ 17.87 VA
2.4 GHz TX50 2x2 MIMO -40	2x2	50%	2 x 22 dBm	-40°C	P = 9.40 W/ 17.00 VA
2.4 GHz TX50 2x2 MIMO +70	2x2	50%	2 x 22 dBm	+70°C	P = 10.18 W/ 19.40 VA
2.4 GHz TX50 3x3 MIMO -40	3x3	50%	3 x 22 dBm	-40°C	P = 10.31 W/ 18.48 VA
2.4 GHz TX50 3x3 MIMO +70	3x3	50%	3 x 22 dBm	+70°C	P = 11.24 W/ 20.93 VA
2.4 GHz TX90 SISO, -40	1x1	90%	1 x 22 dBm	-40°C	P = 9.35 W/ 16.93 VA
2.4 GHz TX90 SISO +70	1x1	90%	1 x 22 dBm	+70°C	P = 9.89 W/ 19.04 VA
2.4 GHz TX90 2x2 MIMO -40	2x2	90%	2 x 22 dBm	-40°C	P = 10.95 W/ 19.37 VA
2.4 GHz TX90 2x2 MIMO +70	2x2	90%	2 x 22 dBm	+70°C	P = 11.83 W/ 22.11 VA
2.4 GHz TX90 3x3 MIMO -40	3x3	90%	3 x 22 dBm	-40°C	P = 12.55 W/ 21.81 VA
2.4 GHz TX90 3x3 MIMO +70	3x3	90%	3 x 22 dBm	+70°C	P = 13.77 W/ 25.18 VA

**Table 23: 2.4 GHz power consumption with 230 VAC**

Test case	Antennas	TX duty cycle	TX output	Amb. Temp.	Avg. Power 230 VAC
2.4 GHz idle	1x1, 2x2, 3x3	2%	1...3 x 22 dBm	-40°C	P = 7.06 W/ 11.96 VA
2.4 GHz idle	1x1, 2x2, 3x3	2%	1...3 x 22 dBm	+70°C	P = 7.89 W/ 15.67 VA
2.4 GHz TX50 SISO, -40	1x1	50%	1 x 21 dBm	-40°C	P = 7.80 W/ 13.16 VA
2.4 GHz TX50 SISO +70	1x1	50%	1 x 21 dBm	+70°C	P = 8.51 W/ 16.39 VA
2.4 GHz TX50 2x2 MIMO -40	2x2	50%	2 x 21 dBm	-40°C	P = 8.65 W/ 14.35 VA
2.4 GHz TX50 2x2 MIMO +70	2x2	50%	2 x 21 dBm	+70°C	P = 9.41 W/ 18.29 VA
2.4 GHz TX50 3x3 MIMO -40	3x3	50%	3 x 21 dBm	-40°C	P = 9.50 W/ 15.54 VA
2.4 GHz TX50 3x3 MIMO +70	3x3	50%	3 x 21 dBm	+70°C	P = 10.31 W/ 20.19 VA
2.4 GHz TX90 SISO, -40	1x1	90%	1 x 21 dBm	-40°C	P = 8.64 W/ 14.61 VA
2.4 GHz TX90 SISO +70	1x1	90%	1 x 21 dBm	+70°C	P = 9.26 W/ 17.85 VA
2.4 GHz TX90 2x2 MIMO -40	2x2	90%	2 x 21 dBm	-40°C	P = 10.16 W/ 16.85 VA
2.4 GHz TX90 2x2 MIMO +70	2x2	90%	2 x 21 dBm	+70°C	P = 10.98 W/ 21.26 VA
2.4 GHz TX90 3x3 MIMO -40	3x3	90%	3 x 21 dBm	-40°C	P = 11.68 W/ 19.09 VA
2.4 GHz TX90 3x3 MIMO +70	3x3	90%	3 x 21 dBm	+70°C	P = 12.70 W/ 24.67 VA

Table 24: 5 GHz power consumption with 100 VAC

Test case	Antennas	TX duty cycle	TX output	Amb. Temp.	Avg. Power 230 VAC
2.4 GHz idle	1x1, 2x2, 3x3	2%	1...3 x 22 dBm	-40°C	P = 7.46 W/ 14.15 VA
2.4 GHz idle	1x1, 2x2, 3x3	2%	1...3 x 22 dBm	+70°C	P = 8.40 W/ 16.42 VA
2.4 GHz TX50 SISO, -40	1x1	50%	1 x 21 dBm	-40°C	P = 8.19 W/ 15.30 VA
2.4 GHz TX50 SISO +70	1x1	50%	1 x 21 dBm	+70°C	P = 8.89 W/ 17.01 VA
2.4 GHz TX50 2x2 MIMO -40	2x2	50%	2 x 21 dBm	-40°C	P = 9.00 W/ 16.60 VA
2.4 GHz TX50 2x2 MIMO +70	2x2	50%	2 x 21 dBm	+70°C	P = 9.74 W/ 18.55 VA
2.4 GHz TX50 3x3 MIMO -40	3x3	50%	3 x 21 dBm	-40°C	P = 9.81 W/ 17.90 VA
2.4 GHz TX50 3x3 MIMO +70	3x3	50%	3 x 21 dBm	+70°C	P = 10.59 W/ 20.09 VA
2.4 GHz TX90 SISO, -40	1x1	90%	1 x 21 dBm	-40°C	P = 9.06 W/ 16.74 VA
2.4 GHz TX90 SISO +70	1x1	90%	1 x 21 dBm	+70°C	P = 9.55 W/ 17.93 VA
2.4 GHz TX90 2x2 MIMO -40	2x2	90%	2 x 21 dBm	-40°C	P = 10.41 W/ 18.34 VA
2.4 GHz TX90 2x2 MIMO +70	2x2	90%	2 x 21 dBm	+70°C	P = 11.24 W/ 20.66 VA
2.4 GHz TX90 3x3 MIMO -40	3x3	90%	3 x 21 dBm	-40°C	P = 11.76 W/ 19.94 VA
2.4 GHz TX90 3x3 MIMO +70	3x3	90%	3 x 21 dBm	+70°C	P = 12.93 W/ 23.39 VA

Table 25: 5 GHz power consumption with 230 VAC

## 5 Outdoor Radio Access Point Configuration and Use

The complete configuration process is described in reference document [1].

### 5.1 LED Indicators During Power Up Sequence

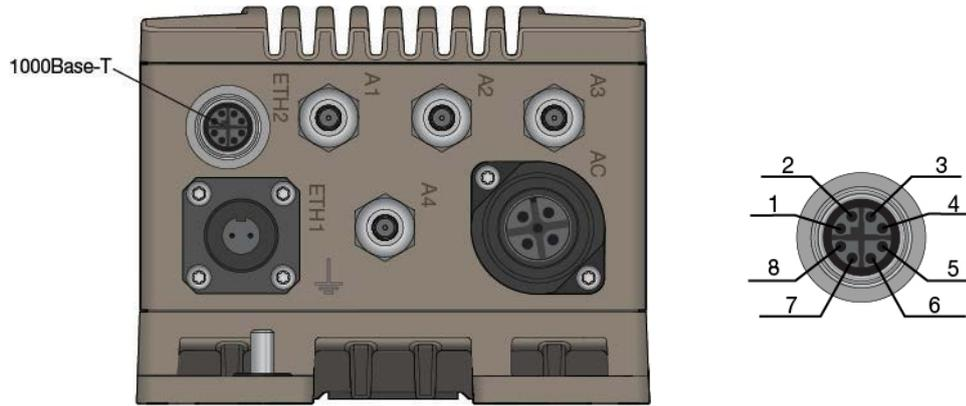
LED behavior during power-up sequence is described in reference document [1] chapter Status Indication.



Figure 16 Power, operation, failure and FO Ethernet interface LEDs

### 5.2 Connecting the service Ethernet

The service 10/100/1000Base-T Ethernet interface can be used either for onsite configuration or for normal backbone interfacing. The service interface has a protective plug, in case using the interface temporarily please install the protecting cap again after the service port use.



**Figure 17 Service 1000Base-TX interface**

The connectors should be assembled with correct torque (appr. 1.0 Nm, check connector manufacturer data).

**NOTICE:** The service Ethernet Interface connector fulfills the IP-protection when the cable plug or the dust cap is connected. If the service Ethernet function is not used in application, the protective dust cap must be closed.

Connector Pin	Signal name, Function	Notes
1	MX1 +	Connector Type: Industrial ETHERNET M12-Socket "X"-coded
2	MX1 -	
3	MX2 +	
4	MX2 -	
5	MX4 +	
6	MX4 -	
7	MX3 -	
8	MX3 +	
<b>Housing</b>	Ground	For possible cable protection/screening

**Table 26 Service 1000Base-TX Connector**

**NOTICE:** The Pinning is compliant to IONA, Industrial Ethernet Planning and Installation Guide, Release 4.0.

### 5.2.1 Service Ethernet Port Features

The Ethernet port supports the following network standards:

Network Standard	Description
<b>10BASE-T</b>	Ethernet over two pairs of twisted wires
<b>100BASE-TX</b>	Fast Ethernet over two pairs of twisted wires
<b>1000BASE-TX</b>	Gigabit Ethernet over four pairs of twisted wires

**Table 27 4.6.1 Ethernet port features**

The Ethernet port support auto-negotiated 10 Mbps / 100 Mbps / 1000 Mbps operation. Automatic MDI/MDIX crossover is supported for 1000BASE-T, 100BASE-T and 10BASE-T operation. For final installation the use of auto-negotiation is however not recommended.

### **5.3 RT-370 Factory Reset Interface, Process for Factory Reset**

A factory reset is not typically needed for the installation. It is required if the device configuration is lost and the device shall be set to a known configuration.

The factory reset is performed with a specific factory reset adapter that is connected to the service Ethernet port during the start-up.

#### **5.3.1 Factory Reset Adapter Specification**

The factory reset adapter is a special plug for the Ethernet interface that activates the factory reset signal.

There is a specific factory reset adapter available:

FACTORY RESET PLUG X-CODED

Part No.: 3623-0799



**Figure 18 Factory reset plug X-coded**

### 5.3.2 Factory Reset Procedure

The Factory Reset is performed with a factory reset adapter that is connected to the service Ethernet port during the start-up.

<b>Step</b>	<b>Description</b>
1.	Plug the factory reset adapter to the service Ethernet interface.
2.	Power the device
3.	Wait until factory reset adapter is detected. This is indicated by an ORANGE operation LED in combination with a RED status LED
4.	Remove factory reset adapter within 15 seconds
5.	A successful initiation of a factory Reset is indicated by an ORANGE BLINKING operation LED in combination with a RED BLINKING failure LED

**Table 28 Factory reset procedure**

After successful factory reset, the dust cap must be closed to ensure the IP requirements.

## 6 Maintenance



**Danger!**

Never try to open the device. There are no serviceable parts inside! By trying to open the device you will be exposed to a risk of death or injury.

### 6.1 Cleaning– Resistance to Chemicals

In case the product is cleaned with cleaning chemicals, the resistance to chemicals of the plastic parts needs to be respected. The following plastic materials are used in RT-370:

**AC Connector**

Polybutylene terephthalate (PBT)

Polyamide 66 (PA66)

**Service Ethernet Connector Dust Cap**

Polyamide 66 (PA66)

Polyurethane (PUR)

**Pressure Equalizer Vent**

Polyamide 6 (PA6)

Polytetrafluoroethylene (PTFE)

**Stickers**

Autotex XE

The resistance to chemicals of the materials mentioned above has been communicated. For guidance which cleaning liquids are allowed for the cleaning of the product, Westermo is to be contacted.

## 6.2 Troubleshooting Based on Functional Behavior

Please read the troubleshooting instructions in reference document [1].

## 6.3 Repair Work

The product is exchanged as a whole. On module level no repair work is done in the field. Broken units need to be returned to the supplier for repair.

### 6.3.1 Product Exchange

<b>Order of Installation Step</b>	<b>Description</b>
<b>1. Remove Cables</b>	Remove cables in the following order: <ul style="list-style-type: none"> <li>• AC cable</li> <li>• Antenna cable A1</li> <li>• Antenna cable A2</li> <li>• Antenna cable A3</li> <li>• Antenna cable A4</li> <li>• Optical cable Do not touch connector end surface. Protect it from damages</li> <li>• Protective earth cable</li> </ul>
<b>2. Open Screw</b>	The 4 M6 screws must be opened and removed completely
<b>3. Exchange</b>	Lift the product out of its position. Place a new product to its position
<b>4. Fix Screws</b>	The 4 M6 screws in each corner must be fixed.
<b>5. Connect Cables</b>	Connect cables in the following order: <ul style="list-style-type: none"> <li>• Protective earth cable</li> <li>• Antenna cable A4</li> <li>• Antenna cable A3</li> <li>• Antenna cable A2</li> <li>• Antenna cable A1</li> <li>• Optical cable Clean optical connector with isopropyl alcohol before installation. Note anti-rotation-key</li> <li>• AC cable</li> </ul> Check correct wiring
<b>6. Configure</b>	Download configuration to the new product

Table 29 Exchange flow