

User Guide
6641-22501
REV. G

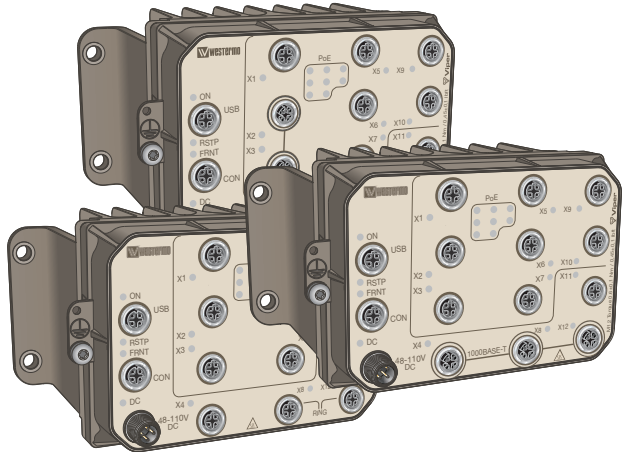

Viper 12A-PoE Series



**12 port Ethernet M12 switches with
Power over Ethernet**

www.westermo.com

Table of Contents

1. General Information	3
1.1. Legal Information	3
1.2. About This Guide	3
1.3. Software Tools	3
1.4. License and Copyright for Included FLOSS	3
1.5. WeOS Management Guide	3
2. Safety and Regulations	4
2.1. Warning Levels	4
2.2. Safety Information	5
2.3. Care Recommendations	6
2.4. Maintenance	7
2.5. Product Disposal	7
2.6. Compliance Information	8
2.6.1. Agency Approvals and Standards Compliance	8
2.6.2. FCC Part 15.105	8
2.6.3. Simplified Declaration of Conformity	8
3. Product Description	10
3.1. Product Description	10
3.2. Available Models	10
3.3. Hardware Overview	12
3.4. Connector Pinout	13
3.5. LED Indicators	15
3.6. Dimensions	15
4. Installation	17
4.1. Wall Mounting	17
4.2. Connection of Cables	17
4.3. Cooling	18
4.4. Removal of Product	18
4.5. EN 45545-2 Mounting Notes	18
5. Specifications	19
5.1. Interface Specifications	19
5.2. Type Tests and Environmental Conditions	22
6. Revision Notes	25

1. General Information

1.1. Legal Information

The contents of this document are provided “as is”. Except as required by applicable law, no warranties of any kind are made in relation to the accuracy and reliability or contents of this document, either expressed or implied, including but not limited to the implied warranties of merchantability and fitness for a particular purpose. Westermo reserves the right to revise this document or withdraw it at any time without prior notice.

Under no circumstances shall Westermo be responsible for any loss of data or income or any special, incidental, and consequential or indirect damages howsoever caused.

More information about Westermo can be found at www.westermo.com.

1.2. About This Guide

This guide is intended for installation engineers and users of the Westermo products.

It includes information on safety and regulations, a product description, installation instructions and technical specifications.

1.3. Software Tools

Related software tools are available at *Software tools* under *Technical support* at www.westermo.com.

1.4. License and Copyright for Included FLOSS

This product includes software developed by third parties, including Free/Libre Open Source Software (FLOSS). The specific license terms and copyright associated with the software are included in each software package respectively. Please visit the product web page for more information.

Upon request, the applicable source code will be provided. A nominal fee may be charged to cover shipping and media. Please direct any source code request to your normal sales or support channel.

1.5. WeOS Management Guide

This product runs WeOS (Westermo Operating System). Instructions for quick start, configuration, factory reset and use of USB port are found in the WeOS Management Guide at www.westermo.com.

2. Safety and Regulations

2.1. Warning Levels

Warning signs are provided to prevent personal injuries and/or damages to the product. The following levels are used:





Level of warning	Description	Consequence personal injury	Consequence material damage
 WARNING	Indicates a potentially hazardous situation	Possible death or major injury	Major damage to the product
 CAUTION	Indicates a potentially hazardous situation	Minor or moderate injury	Moderate damage to the product
 NOTICE	Provides information in order to avoid misuse of the product, confusion or misunderstanding	No personal injury	Minor damage to the product
 NOTE	Used for highlighting general, but important information	No personal injury	Minor damage to the product

Table 1. Warning levels

2.2. Safety Information

Before installation:

Read this manual completely and gather all information available on the unit. Make sure it is fully understood. Check that your application does not exceed the safe operating specifications for this unit.

This unit should only be installed by qualified personnel.

This unit should be built-in to an apparatus cabinet or similar, where access is restricted to service personnel only.

The power supply wiring must be sufficiently fused, and if necessary, it must be possible to disconnect it manually from all power supply. Ensure compliance to national installation regulations.

This unit relies on convection cooling. Make sure that it is installed so that the ambient temperature is within the specified temperature range, e.g. by avoiding obstruction of the airflow around the unit. Also see [EN 45545-2 Mounting Notes \[18\]](#) chapter.



WARNING - PREVENT ACCESS TO HAZARDOUS VOLTAGE

Before mounting, using or removing this unit: Prevent access to hazardous voltage by disconnecting the unit from all power supply.



WARNING - HAZARDOUS VOLTAGE

Do not open the connected unit. Hazardous voltage may occur within this unit when connected to power supply.



CAUTION - HOT SURFACE

Be aware of that the surface of this unit may become hot. When this unit is operated at high temperatures, the external surface of the equipment may exceed Touch Temperature Limit according to EN/IEC/UL 60950-1.



NOTICE - REDUCE RISK OF FIRE

To reduce the risk of fire:

1. Use only No. 18 AWG or larger power cable for Viper LV units
2. Use only No. 21 AWG or larger power cable for Viper HV units
3. Use only No. 26 AWG or larger telecommunication line cord

Additionally, any cable used for Power over Ethernet must fulfill requirements specified in IEEE 802.3.



NOTICE - CONNECT EXTERNAL FUSE

The unit has no internal fuse and should be connected via an external fuse for protection. The fuse must be UL approved and rated for at least 160 VDC / 7.5 A.



NOTICE - ADDITIONAL EMC TYPETESTS

For additional EMC typetests with powering via a CDN or similar high inductive filters, please contact Westermo for correct test setup.

2.3. Care Recommendations

Follow the care recommendations below to maintain full operation of the unit and to fulfill the warranty obligations:

- Do not attempt to disassemble the unit. There are not any user serviceable parts inside.
- Do not drop, knock or shake the unit. Rough handling above the specification may cause damage to internal circuit boards.
- Do not use harsh chemicals, cleaning solvents or strong detergents to clean the unit.
- Do not expose the unit to any kind of liquid (water, beverages, paint etc), unless all connectors are connected or fitted with protective caps (delivered with the unit), tightened to the specified torque. Connected cables must have the appropriate ingress protection code.
- Do not use or store the unit in dusty or dirty areas, unless all connectors and the ventilation membrane are sufficiently protected.
- Do not cover or bring mechanical force to the ventilation membrane on the back of the unit.

If the unit is not working properly, contact the place of purchase, nearest Westermo distributor office or Westermo Tech support.

2.4. Maintenance

No maintenance is required, as long as the unit is used as intended within the specified conditions.

2.5. Product Disposal

This symbol means that the product shall not be treated as unsorted municipal waste when disposing of it. It needs to be handed over to an applicable collection point for recycling electrical and electronic equipment.

By ensuring this product is disposed of correctly, you will help to reduce hazardous substances and prevent potential negative consequences to both environment and human health, which could be caused by inappropriate disposal.



Figure 1. WEEE symbol for treatment of product disposal

2.6. Compliance Information

2.6.1. Agency Approvals and Standards Compliance

Type	Approval/Compliance
Climate	<ul style="list-style-type: none"> EN 50155/IEC 60571 class TX, Railway applications - Electronic equipment used on rolling stock IEEE 1478 class 1, condition E4 (incl Salt Mist), Environmental conditions for transit rail car electronic equipment
EMC	<ul style="list-style-type: none"> EN 61000-6-2, Immunity industrial environments EN 61000-6-4, Emission industrial environments EN 50121-3-2/IEC 62236-3-2 Railway applications – Rolling stock – apparatus Tested and verified for Class S1, DB EMC Regulation 06, Commodity team Radio compatibility in VDB Rev 1.0 (Shunting Radio). Compliant with SBB requirements. Tested and verified for Class S1, ÖBB Radio compatability in near field in accordance with ÖBB Infrastructure Edition 4, Revision 14 (Shunting Radio). Tested and verified for FCC part 15 E-Mark, Road Vehicles, 10R-04 7516^a
Mechanical (Shock and vibration)	<ul style="list-style-type: none"> EN 61373 category 1, class A and B EN 60068-2-27 20 g, 11 ms and 100 g, 6 ms
Insulation (Coordination and test)	<ul style="list-style-type: none"> EN 50124-1, Railway applications – Insulation coordination EN 50155/IEC 60571, Railway applications - Electronic equipment used on rolling stock
Fire protection	<ul style="list-style-type: none"> EN 45545-2, Fire protection on railway vehicles NFPA 130, Fire protection for fixed guideway transit and passenger rail system

^aApplicable only for Viper-x12A-P8-HV, Viper-x12A-P8-LV, Viper-x12A-T3G-P8-HV and Viper-x12A-T3G-P8-LV

Table 2. Agency approvals and standards compliance

2.6.2. FCC Part 15.105

This equipment has been tested and found to comply with the limits for a Class A digital device, pursuant to Part 15 of the FCC Rules.

These limits are designed to provide reasonable protection against harmful interference when the equipment is operated in a commercial environment.

This equipment generates, uses, and can radiate radio frequency energy and, if not installed and used in accordance with the instruction manual, may cause harmful interference to radio communications. Operation of this equipment in a residential area is likely to cause harmful interference in which case the user will be required to correct the interference at the users own expense.

2.6.3. Simplified Declaration of Conformity

Hereby, Westermo declares that the equipment is in compliance with applicable EU directives. The full EU declaration of conformity and other detailed information is available at the respective product page at www.westermo.com.



Figure 2. The European conformity marking

3. Product Description

3.1. Product Description

The Viper-12A-PoE series is a series of managed 12 port switches optimised for the needs of the railway rolling stock market. PoE ports offer effective powering of end-devices. Gbps ports cope with high bandwidth devices such as access points and NVRs (Network Video Recorders).

The Viper is designed to withstand the tough environment on-board trains, exposing the switch to constant vibration, extreme temperatures, humidity and a demanding electrical environment.

A GORE-TEX® membrane prevents internal condensation. Threading integrated in chassis provides for additional vibration resistance. High-level isolation between all interfaces enables direct connectivity to vehicle auxiliary power and protects against overvoltage and flashover. IP67 protection prevents ingress of water and dust. An overall optimised design results in an extremely compact package in combination with very high MTBF for easy integration and low lifecycle cost.

Thorough type testing at independent ISO/IEC 17025 and ILAC MRA certified labs, accredited to a wide range of standards, show that the Viper series fulfills EN 50155 and other requirements. The state-of-the-art Westermo production facility ensures the quality of each individual unit, e.g. through temperature cycling burn-in testing.

Meeting the requirements of the railcar market, the Viper is very well suited for deployment in any other application with severe operating conditions and tough environments, for instance in the mining industry.

3.2. Available Models

All switches are managed and have eight PoE ports. Viper x12A-PoE is used when referring to both models 112A-PoE and 212A-PoE.

Art.no	Model	Layer	Gbps ports	HV	LV
3635-0110	Viper-112A-P8-HV	2	-	48 - 110 V	
3635-0120	Viper-212A-P8-HV	3	-	48 - 110 V	
3635-0210	Viper-112A-P8-LV	2	-		24 - 38 V
3635-0220	Viper-212A-P8-HV	3	-		24 - 38 V
3635-0410	Viper-112A-T3G-P8-HV	2	3	48 - 110 V	
3635-0420	Viper-212A-T3G-P8-HV	3	3	48 - 110 V	
3635-0510	Viper-112A-T3G-P8-LV	2	3		24 - 38 V
3635-0520	Viper-A12A-T3G-P8-LV	3	3		24 - 38 V
3635-0710	Viper-112A-T5G-P8-HV	2	5	48 - 110 V	
3635-0720	Viper-212A-T5G-P8-HV	3	5	48 - 110 V	
3635-0810	Viper-112A-T5G-P8-LV	2	5		24 - 38 V
3635-0820	Viper-212A-T5G-P8-LV	3	5		24 - 38 V

Table 3. Available Viper x12A-P8 models

3.3. Hardware Overview

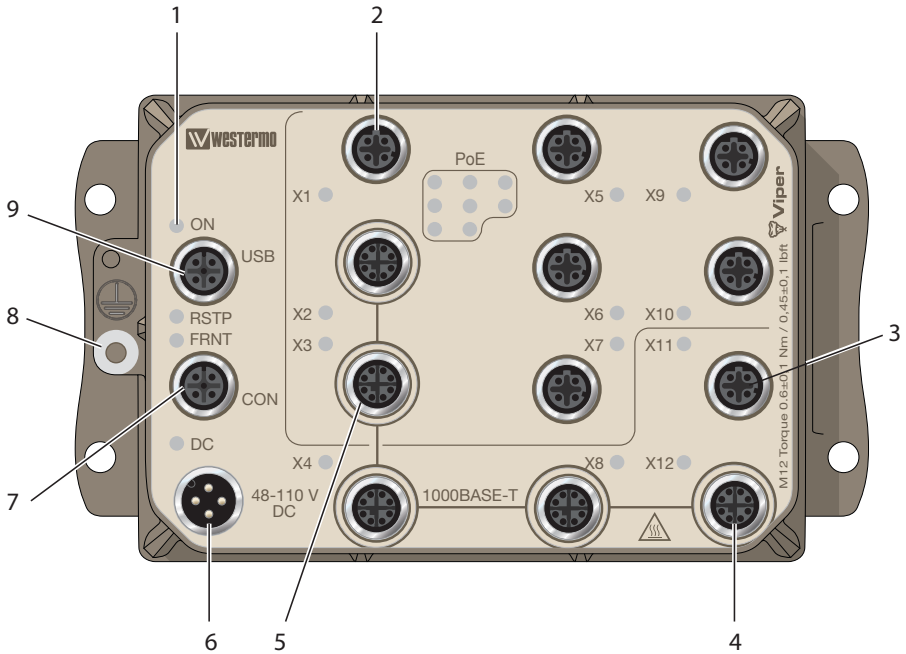

No.	Description	No.	Description
1	LED indicator	2	100 Mbps PoE port
3	100 Mbps port	4	Gbps port
5	Gbps PoE port	6	Power connection
7	Console port	8	Protective earth connection
9	USB port		

Figure 3. Location of interface ports and LED indicators

3.4. Connector Pinout

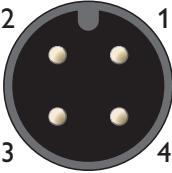
Pin no.	Signal	Illustration
1	+DC1	
2	+DC1	
3	-COM	
4	-COM	

The Viper-12A-PoE series has single power connection. Dual pins shall be connected to the power supply (+DC1 for positive terminal, -COM for negative terminal) in order to distribute the current over two pins.

Table 4. Power connector HV

Pin no.	Signal	Illustration
1	+DC1	
2	+DC1	
3	-COM	
4	-COM	

The Viper-12A-PoE series has single power connection. Dual pins shall be connected to the power supply (+DC1 for positive terminal, -COM for negative terminal) in order to distribute the current over two pins.

Table 5. Power connector LV

Pin no.	Signal	Illustration
1	NC	
2	TX	
3	RX	
4	NC	
5	GND	

Table 6. Console connector

Pin no.	Signal	Illustration
1	DN	
2	VBUS	
3	NC	
4	DC	
5	GND	

Table 7. USB connector

Pin no.	Signal	Illustration
1	TD+	
2	RD+	
3	TD-	
4	RD-	
<p>MDI, MDI-X and auto MDI/MDI-X modes are supported. The table shows signals in MDI mode.</p>		

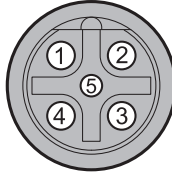
Table 8. 100 Mbps Ethernet connector

Pin no.	Signal	Illustration
1	DA+	
2	DA-	
3	DB+	
4	DB-	
5	DD+	
6	DD-	
7	DC-	
8	DC+	

Table 9. Gbps connector

3.5. LED Indicators

LED	Status	Description
ON	OFF	Unit has no power
	GREEN	All OK, no alarm condition
	RED	Alarm condition, or until unit has started up. (Alarm conditions are configurable, see <i>WeOS Management Guide</i>)
	BLINK	Location indicator ("Here I am!"). Activated when connected to WeConfig tool, or upon request from web or/and CLI. RED BLINK during boot indicates pending cable factory reset.
RSTP	OFF	RSTP disabled
	GREEN	RSTP enabled
	BLINK	Unit selected as RSTP/STP root switch
FRNT	OFF	FRNT disabled
	GREEN	FRNT OK
	RED	FRNT error
	BLINK	Unit configured as FRNT focal point
DC	OFF	Unit has no power
	GREEN	Power OK. Input voltage > 70% of minimum nominal voltage
	RED	Power failure. Input voltage < 70 % of minimum nominal voltage
X1 to X12	OFF	No link
	GREEN	Link established
	GREEN FLASH	Data traffic indication
	YELLOW	Port alarm, or port is set in blocking state by link redundancy protocol
PoE	OFF	Port does not consume PoE power
	GREEN	Port consumes PoE power

Table 10. LED indicators

3.6. Dimensions

Dimensions are stated in millimetres and are regardless of HV or LV model.

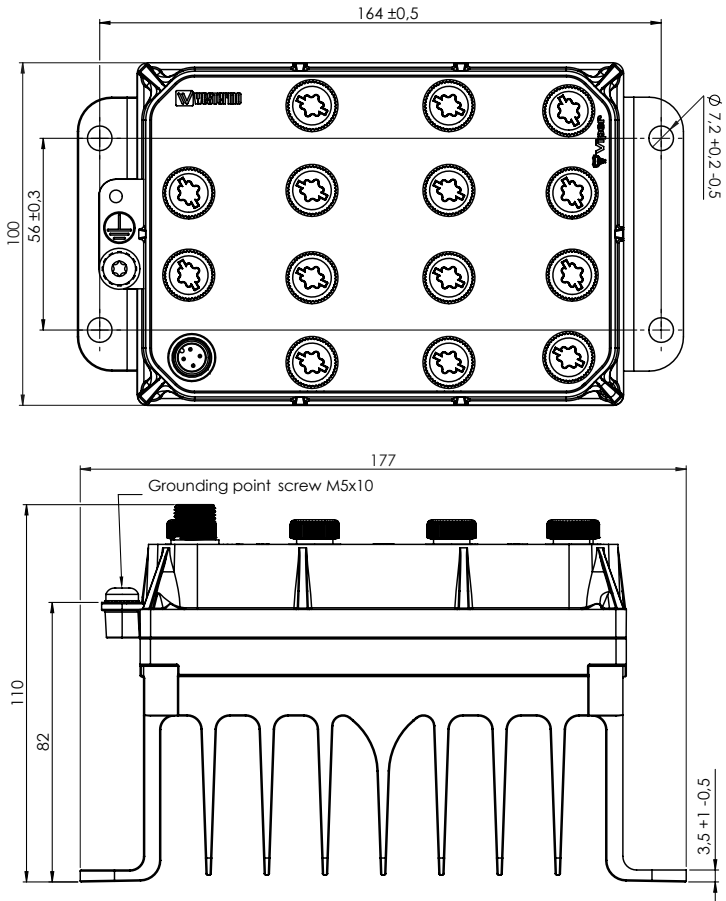

Figure 4. Dimensional drawing

4. Installation

4.1. Wall Mounting

The unit can be wall mounted vertically or horizontally. There are four pieces of 7 mm bores for this. Use four M5, M6 or 1/4" screws with 12 mm washers on a flat and stable surface.

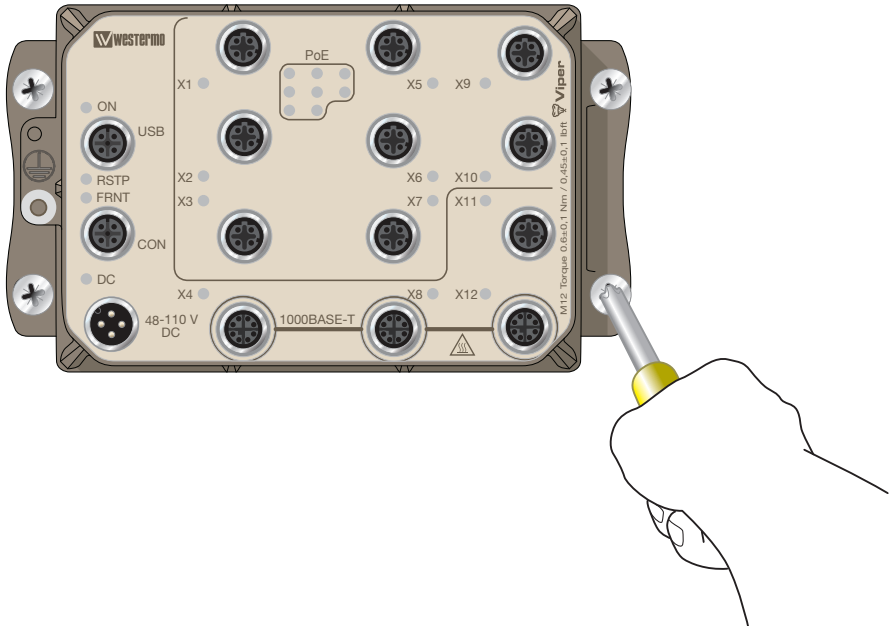

Figure 5. Wall mounting

4.2. Connection of Cables

Recommended tightening torque for the M12 connectors is 0.6 Nm.

When connecting the power cable, ensure that the pins are connected correctly before tightening the power cable to the unit.



NOTICE - UNUSED CONNECTORS

Unused connectors must be covered by a protective cap (delivered with the unit), tightened to the specified torque in order to fulfill the specified ingress protection code.



NOTICE - CONNECT EXTERNAL FUSE

The unit has no internal fuse and should be connected via an external fuse for protection. The fuse must be UL approved and rated for at least 160 VDC / 7.5 A.

4.3. Cooling

This unit relies on convection cooling. Make sure that it is installed so that the ambient temperature is within the specified temperature range, e.g. by avoiding obstruction of the airflow around the unit.

4.4. Removal of Product

Disconnect all cables and unscrew the unit from the wall. Time for replacement: < 10 minutes.



CAUTION - HOT SURFACE

Be aware of that the surface of this unit may become hot. When this unit is operated at high temperatures, the external surface of the equipment may exceed Touch Temperature Limit according to EN/IEC/UL 60950-1.

4.5. EN 45545-2 Mounting Notes

Two units can be mounted together and as a single interior non-listed group in the sense of EN 45545-2 definitions. For multiple units, the spacing requirements for interior non-listed groups must be met.

5. Specifications

5.1. Interface Specifications

DC, Power port	
Rated voltage	Viper-x12A LV units: 24 to 38 VDC Viper-x12A HV units: 48 to 110 VDC
Operating voltage	Viper-x12A LV units: 16.8 to 49.9 VDC (14.4 to 53.2 VDC for 100 ms) Viper-x12A HV units: 33.6 to 143 VDC (28.8 to 154 VDC for 100 ms)
Rated current	Viper-x12A LV units: max 4.6 A at 24 VDC, max 2.9 A at 38 VDC Viper-x12A HV units: max 2.4 A at 48 VDC, max 1.0 A at 110 VDC
Rated frequency	DC
Inrush current, I _{st}	Viper-x12A LV units: 540 mA ² s at 24 VDC, 410 mA ² s at 38 V Viper-x12A HV units: 190 mA ² s at 48 VDC, 160 mA ² s at 110 V
Startup current ³	Viper-x12A LV units: 1.5 A at 16.8 VDC Viper-x12A HV units: 750 mA at 33.6 VDC
Polarity	Reverse polarity protected
Redundant power input	No
Isolation	2250 VDC to all other ports
Connector	Viper-x12A LV units: 4-pin, male, M12, T-coded, recommended Westermo cable: 3146-1108 for 5 m Viper-x12A HV units: 4-pin, male, M12, A-coded, recommended Westermo cables: 3146-1106 for 1.5 m 3146-1107 for 5 m
Cable size	For Viper-x12A HV units: M12, recommended cable area 0.5 mm ² (minimum 0.25 mm ²) For Viper-x12A LV units: M12, recommended cable area 1 mm ² (minimum 0.75 mm ²) Cable dimensions depend on choice of M12 connector

³External supply current capability for proper startup

100 Mbps ports, non-PoE^a	
Electrical specification	IEEE std 802.3
Data rate	10 Mbps, 100 Mbps, manual or auto
Duplex	Full or half, manual or auto
Circuit type	TNV-1
Transmission range	Up to 150 m with CAT5e cable or better
Isolation	2250 VDC, 1 min ^b
Connector	4-pin, female, M12, D-coded, auto MDI/MDI-X, recommended Westermo cables: 3146-1100 M12-M12 - 1 m 3146-1101 M12-M12 - 5 m 3146-1103 RJ45-M12 - 1 m 3146-1104 RJ45-M12 - 5 m
Shielded cable	Required
Conductive chassis	Yes
FRNT reconfiguration time	Typically below 20 ms

^a100 Mbps ports, non-PoE, are:
X4, X8, X11-X12 on Viper-x12A-P8-HV/LV
X11 on Viper-x12A-TxG-P8-HV/LV

^b750 VDC after damp heat, according to EN 50155

Gbps ports, non-PoE^a	
Electrical specification	IEEE std 802.3
Data rate	10 Mbps, 100 Mbps, 1000 Mbps, manual or auto
Circuit type	TNV-1
Transmission range	Up to 100 m with CAT5e cable or better
Isolation	2250 VDC to all other ports ^b
Connector	8-pin, female, M12, X-coded
Shielded cable	Required
FRNT reconfiguration time	Typically below 20 ms

^aGbps ports, non-PoE are: X4, X8, X12 on Viper-x12A-TxG-P8-HV/LV

^b750 VDC after damp heat, according to EN 50155

PoE ports, 100 Mbps and Gbps^a

Electrical specification	IEEE std 802.3
Circuit type	TNV-1
Transmission range	Up to 100 m with CAT5e cable or better
Isolation	2250 VDC to all other ports ^b
Output voltage	54 VDC, $\pm 5\%$
Output power ^c	Max 30 W on one port (PoE+) Max 80 W in total on all ports

^aPoE ports are: X1-X3, X5-X7, X9-X10. X2 and X3 are Gbps for Viper-x12A-T5G-P8-LV/HV.

^b750 VDC after damp heat, according to EN 50155

^cAs delivered by Power Sourcing Equipment, i.e. the Viper-x12A-PoE switch. Power available at Powered Device is depending on the cable resistance.



NOTE

PoE ports are not isolated to each other, except on a functional level.

USB port

Electrical specification	USB 2.0 host interface
Data rate	Up to 480 Mbps (high-speed mode)
Maximum supply current	500 mA
Circuit type	SELV
Isolation	To Ethernet and DC ports: 2250 VDC No isolation to CON or chassis
Connector	5-pin, female, M12, A-coded, recommended Westermo USB plug 3641-0190

Console port

Electrical specification	RS-232
Data rate	115.2 kbit/s
Data format	8 data bits, no parity, 1 stop bit, no flow control
Circuit type	SELV
Isolation	To Ethernet and DC ports: 2250 VDC No isolation to USB or chassis
Connector	5-pin, female, M12, B-coded, recommended Westermo cables: 1211-2215 (serial port) or 1211-4073 (USB)

5.2. Type Tests and Environmental Conditions

Environmental phenomena	Basic standard	Description	Test levels
ESD	EN 61000-4-2	Enclosure	Contact: ± 6 kV Air: ± 8 kV
Fast transients	EN 61000-4-4	Power port	± 2 kV
		Signal ports	
		Earth port	
Surge	EN 61000-4-5	Power port	L-E: ± 2 kV, 42Ω , $0.5 \mu\text{F}$, $1.2/50 \mu\text{s}$ L-E: ± 0.5 kV, 12Ω , $9 \mu\text{F}$, $1.2/50 \mu\text{s}$ L-L: ± 2 kV, 42Ω , $0.5 \mu\text{F}$, $1.2/50 \mu\text{s}$ L-L: ± 0.5 kV, 2Ω , $18 \mu\text{F}$, $1.2/50 \mu\text{s}$
		Ethernet port	L-E: ± 2 kV, 2Ω
Pulsed magnetic field	EN 61000-4-9	Enclosure	300 A/m
Radiated RF immunity	EN 61000-4-3	Enclosure	20 V/m at (80 MHz to 2 GHz) 10 V/m at (2-6 GHz) 1 kHz sine, 80% AM
Conducted RF immunity	EN 61000-4-6	Power port	10 V, 80% AM, 1 kHz; (0.15-80) MHz
		Ethernet ports	
		Earth port	
Radiated RF emission	CISPR 16-2-3	Enclosure	EN 61000-6-4 (80-6000 MHz)
	ANSI C63,4 (FCC Part 15)		EN 61000-6-4 (80-6500 MHz)
Conducted RF emission	CISPR 16-2-1	Power port	EN 61000-6-4
		Ethernet ports	EN 61000-6-3
Dielectric strength	EN 60950-1	Power port to all other ports	2250 VDC, 1 min
		Ethernet ports to all other ports	2250 VDC, 1 min ^a
		Gbps Ethernet ports to all other ports	2250 VDC, 1 min ^a
		PoE ports to all other ports	2250 VDC, 1 min ^a

^a750 VDC after damp heat, according to EN 50155

Table 11. EMC and electrical conditions

Environmental phenomena	Basic standard	Description	Test levels
Temperatures	EN 60068-2-1 EN 60068-2-2	Operating	-40 to +70°C (-40 to +158°F) ^{ab}
		Storage and transport	-55 to +85°C (-67 to +185°F)
Humidity	EN 60068-2-30	Operating	5-95% relative humidity
		Storage and transport	
Altitude		Operating	2000 m/70 kPa
Service life		Operating	20 years according to IEC/TR 62380
MTBF		Viper-x12A-P8-LV: 1: 404,000 hours	1: MIL-C217F2, GB, 25°C (+77°F) 2: IEC 62380
		Viper-x12A-P8-HV: 1: 403,000 hours	
		Viper-x12A-T3G-P8-LV: 1: 400,000 hours 2: 471,000 hours	
		Viper-x12A-T3G-P8-HV: 1: 399,000 hours 2: 471,000 hours	
		Viper-x12A-T5G-P8-LV/HV: 1: 392,000 hours	
Vibration	IEC 60068-2-6 (sine)	Operational	2 g rms 5-500 Hz, 5 sweeps
	IEC 60068-2-64 (random)	Non-operational long life simulation	11.44 m/s ² rms 5-150 Hz, 5 hours
Shock	IEC 60068-2-27	Operational	10 g, 30 ms, half sine 20 g, 11 ms, saw tooth 100 g, 6 ms, half sine
Enclosure	EN 60950-1	Zinc (front), Aluminium (rear)	Fire enclosure
Dimension WxHxD with connectors			See "Dimensions" chapter for details
Weight			1.7 kg
Degree of protection	EN 60529	Enclosure	IP67 ^c
Cooling			Convection

^aRefer to "Safety and Regulations" chapter regarding touch temperature

^bOperational at +85°C for a limited time

°Provided all connectors are connected with IP67 cabling or fitted with protective caps (delivered with the unit) and tightened to the specified torque.

Table 12. Environmental and mechanical conditions

6. Revision Notes

Revision	Date	Change description
Rev. G	2018-12	Viper-x12A-T5G-P8-HV and -LV added. 2.2 Safety Information with specific symbol for Caution - Hot surface, and text in Notice - Connect external fuse updated, 2.5 Environmental Protection updated to Product disposal, 2.6.1 Agency Approvals table updated, 2.6.3 Declaration of Conformity updated to Simplified Declaration of Conformity, 3.2 more models added, 3.3 Hardware Overview table updated, 4.2 updated with Notice - Connect external fuse, chapter 4.4 symbol for Caution - Hot surface updated, 5.1 Interface specifications - Gbps ports; Transmission range updated, PoE ports note A updated, Note updated, inrush current updated, 5.2 Type Tests and Environmental Conditions - enclosure updated, end page updated
Rev. F	2017-09	2.1 Definition of personal injury at Caution level updated, 2.2 Notice on additional EMC typetests added, 2.6.1 Mechanical data updated, 3.6 Dimensional drawing updated, 5.1 DC, Power port "Inrush current updated", Gbps ports, non-PoE "Isolation to" updated, PoE ports "Output power" updated to 30 W on one port, Transmission range for 100 Mbps ports and Gbps ports changed to 150 m, 5.2 Power frequency magnetic field test deleted, Enclosure updated, Radiated + Conducted RF emission updated
Rev E	2017-07	New layout for user guide with rearranged chapters, chapter 1 has updated texts and new chapter 1.5, new defining Warning levels in chapter 2.1, updated text in chapter 3.1, \pm removed from ± 2250 and ± 750 VDC throughout the user guide, radiated RF immunity, service life and shock updated in chapter 5.2 Old chapters Getting started, Configuration, Reference documents and Cable factory reset are deleted.



Westermo • SE-640 40 Stora Sundby, Sweden
Tel +46 16 42 80 00 Fax +46 16 42 80 01
E-mail: info@westermo.com
www.westermo.com