

USERGUIDE

Wolverine DDW-142-485 DDW-242-485

Industrial Ethernet Extender

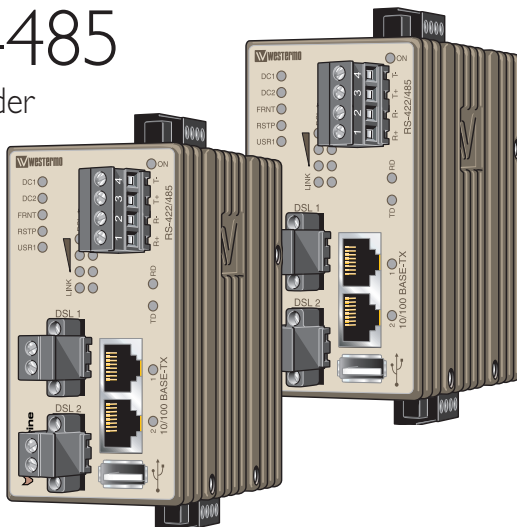

General information

Legal information

The contents of this document are provided “as is”. Except as required by applicable law, no warranties of any kind, either express or implied, including, but not limited to, the implied warranties of merchantability and fitness for a particular purpose, are made in relation to the accuracy and reliability or contents of this document. Westermo reserves the right to revise this document or withdraw it at any time without prior notice.

Under no circumstances shall Westermo be responsible for any loss of data or income or any special, incidental, and consequential or indirect damages howsoever caused.

More information about Westermo can be found at the following Internet address:
www.westermo.com

Software tools

Related software tools are available in the folder software tools under technical support on the Westermo website.

License and copyright for included Free/Libre Open Source Software

This product includes software developed by third parties, including Free/Libre Open Source Software (FLOSS). The specific license terms and copyright associated with the software are included in each software package respectively. Please visit the product web page for more information.

Upon request, the applicable source code will be provided. A nominal fee may be charged to cover shipping and media. Please direct any source code request to your normal sales or support channel.

WeOS Management Guide

This product runs WeOS (Westermo Operation System). Instructions for quick start, configuration, factory reset and use of USB port are found in the WeOS Management Guide at www.westermo.com.

Safety



Before installation:

Read this manual completely and gather all information on the unit. Make sure that you understand it fully. Check that your application does not exceed the safe operating specifications for this unit.

This unit should only be installed by qualified personnel.

This unit should be built-in to an apparatus cabinet, or similar, where access is restricted to service personnel only.

The power supply wiring must be sufficiently fused, and if necessary it must be possible to disconnect manually from the power supply. Ensure compliance to national installation regulations.

This unit uses convection cooling. To avoid obstructing the airflow around the unit, follow the spacing recommendations (see Cooling section).

"Note that this unit can be connected to two different power sources."



Before mounting, using or removing this unit:

Prevent access to hazardous voltage by disconnecting the unit from power supply.

Warning! Do not open connected unit. Hazardous voltage may occur within this unit when connected to power supply.

When this unit is operated at an ambient temperature above +60°C (+140°F), forced ventilation is required to not exceed Touch Temperature Limits according to UL/IEC/EN 60950-1. A recommended airflow 32CFM (61m³/h) located 17cm (7") below the unit is a minimum requirement. To reduce the risk of fire, use only No. 26 AWG or larger telecommunication line cord.

Care recommendations

Follow the care recommendations below to maintain full operation of unit and to fulfil the warranty obligations.

This unit must not be operating with removed covers or lids.

Do not attempt to disassemble the unit. There are no user serviceable parts inside.

Do not drop, knock or shake the unit, rough handling above the specification may cause damage to internal circuit boards.

Do not use harsh chemicals, cleaning solvents or strong detergents to clean the unit.

Do not paint the unit. Paint can clog the unit and prevent proper operation.

Do not expose the unit to any kind of liquids (rain, beverages, etc). The unit is not waterproof. Keep the unit within the specified humidity levels.

Do not use or store the unit in dusty, dirty areas, connectors as well as other mechanical part may be damaged.

If the unit is not working properly, contact the place of purchase, nearest Westermo distributor office or Westermo Tech support.

A readily accessible disconnect device shall be incorporated external to the equipment.

This unit may have hot surfaces when used in high ambient temperature.

Maintenance

No maintenance is required, as long as the unit is used as intended within the specified conditions.

Product disposal



This symbol means that the product shall not be treated as unsorted municipal waste when disposing of it. It needs to be handed over to an applicable collection point for recycling electrical and electronic equipment.

By ensuring this product is disposed of correctly, you will help to reduce hazardous substances and prevent potential negative consequences to both environment and human health, which could be caused by inappropriate disposal.

Simplified EU declaration of conformity

Hereby, Westermo declares that the equipment is in compliance with EU directives. The full EU declaration of conformity and other detailed information are available at the respective product page at www.westermo.com.

Agency approvals and standards compliance

Type	Approval / Compliance
EMC	EN 50121-4, Railway signalling and telecommunications apparatus
	EN 61000-6-1, Immunity residential environments
	EN 61000-6-2, Immunity industrial environments
	EN 61000-6-3, Emission residential, commercial and light-industrial environments
	EN 61000-6-4, Emission industrial environments
	IEC 62236-4, Railway signalling and telecommunications apparatus
Safety	UL/IEC/EN 60950-1, IT-equipment
Marine	DNV GL rules for classification – Ships and offshore units

FCC Part 15.105 Notice:

This equipment has been tested and found to comply with the limits for a Class B digital device, pursuant to Part 15 of the FCC Rules. These limits are designed to provide reasonable protection against harmful interference in a residential installation. This equipment generates, uses and can radiate radio frequency energy and, if not installed and used in accordance with the instructions, may cause harmful interference to radio communications. However, there is no guarantee that interference will not occur in a particular installation. If this equipment does cause harmful interference to radio or television reception, which can be determined by turning the equipment off and on, the user is encouraged to try to correct the interference by one or more of the following measures:

- ⌘ Reorient or relocate the receiving antenna
- ⌘ Increase the separation between the equipment and receiver
- ⌘ Connect the equipment into an outlet on a circuit different from that to which the receiver is connected
- ⌘ Consult the dealer or an experienced radio/TV technician for help.

Corrosive environment Notice:

This product has been successfully tested in a corrosion test according to *IEC 60068-2-60, method 3*. This means that the product meets the requirements to be placed in an environment classified as *ISA-S71.04 class G3*.

Note! If the product is placed in a corrosive environment, it is important that all unused connector sockets are protected with a suitable plug in order to avoid corrosion attacks on the gold plated pins in connectors.

Type tests and environmental conditions

Electromagnetic Compatibility			
Environmental phenomena	Basic standard	Description	Test levels
Electrostatic discharge	EN 61000-4-2	Enclosure	Contact: ± 6 kV Air: ± 8 kV
Fast transients	EN 61000-4-4	Power port	± 2 kV
		Ethernet ports	± 2 kV
		SHDSL ports	± 2 kV
		RS-422/485 port	± 2 kV
		Status out / Digital in	± 2 kV
Surge	EN 61000-4-5	Power port	L-L: ± 0.5 kV, 2Ω , $18 \mu\text{F}$ L-E: ± 0.5 kV, 12Ω , $9 \mu\text{F}$ L-E: ± 2 kV, 42Ω , $0.5 \mu\text{F}$ L-L: ± 1 kV, 42Ω , $0.5 \mu\text{F}$
		Ethernet ports (Shielded cable)	L-E: ± 2 kV, 2Ω
		SHDSL ports	L-E: ± 2 kV, 42Ω , $0.5 \mu\text{F}$
		RS-422/485 port	L-E: ± 2 kV, 2Ω
		Status out / Digital in	L-E: ± 2 kV, 42Ω , $0.5 \mu\text{F}$
	EN 55024	Ethernet ports (Shielded cable)	L-E: ± 1 kV, 15Ω
		SHDSL ports	L-E: ± 1 kV, 40Ω ($15 + 25 \Omega$)
		RS-422/485 port	L-E: ± 1 kV, 40Ω ($15 + 25 \Omega$)
		Status out / Digital in	L-E: ± 1 kV, 40Ω ($15 + 25 \Omega$)
		Pulse magnetic field	EN 61000-4-9
Radiated RF immunity	EN 61000-4-3	Enclosure	20 V/m 80% AM, 1 kHz sine, 80 – 1000 MHz 12 V/m 80% AM, 1 kHz sine, 1000 – 2700 MHz 10 V/m 80% AM, 1 kHz sine, 2700 – 6000 MHz
Conducted RF immunity	EN 61000-4-6	Power port	10 V, 80% AM, 1 kHz sine; 0.15 – 80 MHz
		Ethernet ports	10 V, 80% AM, 1 kHz sine; 0.15 – 80 MHz
		SHDSL ports	10 V, 80% AM, 1 kHz sine; 0.15 – 80 MHz
		RS-422/485 port	10 V, 80% AM, 1 kHz sine; 0.15 – 80 MHz
		Status out / Digital in	10 V, 80% AM, 1 kHz sine; 0.15 – 80 MHz
Voltage dips and interruption	EN 61000-4-29	DC Power port	10 ms, interruption 500 ms, 30% reduction 200 ms, 60% reduction +20 above & -20% below rated voltage
Radiated RF emission	CISPR 16-2-3 ANSI C63.4 (FCC part 15)	Enclosure	Class B
			Class B
Conducted RF emission	CISPR 16-2-1	Power port	Class B
			Class B
		Ethernet ports	Class B
			Class B

Dielectric strength	EN 60950-1	Power port to other isolated ports	2000 Vrms 50 Hz 1 min
		Ethernet ports to all other isolated ports	1500 Vrms 50 Hz 1 min
		RS-422/485 port to all other isolated ports	
		SHDSL ports to all other isolated ports	
		Status out / Digital in port to all other isolated ports	
Environmental			
Temperature	EN 60068-2-1 EN 60068-2-2	Operating	-40 to +70°C (-40 to +158°F)
		Storage & Transport	-40 to +85°C (-40 to +185°F)
Humidity	EN 60068-2-30	Operating	5 to 95% relative humidity
		Storage & Transport	5 to 95% relative humidity
Corrosive gases	IEC 60068-2-60	Operating	Method 3, 21 days*
Altitude		Operating	2 000 m / 70 kPa
Service life		Operating	10 years
Reliability prediction (MTBF)		Operating	435,000 hours (MIL-HDBK- 217F2, GB, 25°C)
Vibration	IEC 60068-2-64 (random)	Operating	5 – 20 Hz: 2 m ² /s ³ 20 – 500 Hz: - 3 dB/oct 3 axis = 3 * 30 min
Shock	IEC 60068-2-27	Operating	6 ms 1000 m/s ² 6 directions, 3 shocks/direction
Bump	IEC 60068-2-27	Operating	11 ms 100 m/s ² 6 directions, 100 shocks/direction
Packing			
Enclosure material	EN 60950-1		Zinc (fire enclosure)
Dimension W x H x D		Without connectors	52.5 x 100 x 92 mm
		With connectors	52.5 x 100 x 111 mm
Weight			0.8 kg
Degree of protection	EN 60529	Enclosure	IP40
Cooling			Convection
Mounting		Enclosure	Horizontal on 35 mm DIN-rail

*Method 3, 21 days corresponds to Harsh Industrial Environment G3 which is defined in ANSI/ISA 17.04: 2015

Description

Functional description

The Wolverine DDW-142-485 and DDW-242-485 allow effective Ethernet networks to be created over long distances up to 15 km (9.3 mi) at data rates up to 15.3 Mbit/s on a single twisted pair cable. By using two pairs “bonded” this rate can be doubled up to 30.6 Mbit/s. The integral switch allows two Ethernet devices to be attached and an RS-422/485 port allows for a legacy piece of equipment to be incorporated into the IP network.

The operating system (WeOS) in DDW-142-485 and DDW-242-485 can deliver unique security functionality for this class of product as well as allowing the product to form part of a resilient multimedia ring network using the Westermo FRNT protocol or industry standard STP/RSTP.

WeOS has been developed to provide industrial networking solutions and contains amazing serial connectivity capability – from being able to simulate an old AT modem, convert Modbus RTU to TCP or encapsulate serial data into an IP packet.

DDW-142-485 supports the layer 2 features in WeOS while DDW-242-485 also supports all layer 3 features, for more details please see the WeOS datasheet.

WeOS has been developed to provide industrial networking solutions and contains amazing serial connectivity capability – from being able to simulate an old AT modem, convert Modbus RTU to TCP or encapsulate serial data into an IP packet.

DDW-142-485 and DDW-242-485 are incredibly flexible and easy to use. A basic point-to-point or multidrop network can be created without the need for any kind of configuration. If however a more complex solution requires some kind of network configuration the Web based setup is simple to use. A CLI interface is also provided making the unit easy for networking professionals to quickly master. Once the system is configured an easy solution is also available for the maintenance engineer – USB backup and restore means that stored configurations can be automatically downloaded from a USB stick.

DDW-142-485 and DDW-242-485 are often used in applications on railways, roads or with utilities where failure could result in significant costs. All Westermo products are designed with high MTBF in mind to improve operational reliability and also give long service life. Even features like the SHDSL diagnostics and management allow indication of line degradation allowing planned maintenance. As the unit is designed for these applications Westermo also ensure that testing is carried out to ensure the unit can operate at extremes of temperature, EMC and vibration and still provide robust communications.

Interface specifications

Power	
Rated voltage	24 to 48 VDC
Operating voltage	19 to 60 VDC
Rated current	245 mA (405 mA) @ 24 VDC (with 500 mA USB load) 124 mA (200 mA) @ 48 VDC (with 500 mA USB load)
Rated frequency	DC
Inrush current, I ² t	10.6 mA ² s @ 24 VDC 24.7 mA ² s @ 36 VDC 42.4 mA ² s @ 48 VDC
Startup current*)	2 x Rated current
Polarity	Reverse polarity protected
Redundant power input	Yes
Isolation to	All other
Connection	Detachable screw terminal
Connector size	0.2 – 2.5 mm ² (AWG 24 – 13) Connect the unit using at least 18 AWG (0.75 mm ²) wiring
Shielded cable	Not required

* External supply current capability for proper start-up.

RS-422/485	
Electrical specification	EIA RS-422/485
Data rate	50 bit/s – 2 Mbit/s
Data format	7 or 8 data bits, Odd, even or none parity, 1 or 2 stop bits (2 stop bits only when no parity is set).
Circuit type	TNV-1
Transmission range	Up to 1200 m / 0.74 mi, depending on data rate and cable type
Isolation to	Power, I/O relay output, I/O Digital input, SHDSL line, Ethernet
Connection	Detachable screw terminal
Connector size	0.2 – 2.5 mm ² (AWG 24 – 12)
Shielded cable	Not required, but recommended in railway installations close to the rails.*
Conductive housing	Yes

* To minimise the risk of interference, a shielded cable is recommended when the cable is located inside 3 m boundary or the cable is longer than 30 m and inside 10 m boundary to the rails and connected to this port.

Ethernet TX	
Electrical specification	IEEE std 802.3. 2005 Edition
Data rate	10 Mbit/s, 100 Mbit/s, manual or auto
Duplex	Full or half, manual or auto
Circuit type	TNV-1
Transmission range	Up to 150 m, with CAT5e cable or better
Isolation to	All other
Connection	RJ-45, auto MDI/MDIX
Shielded cable	Not required, except when installed in Railway applications as signalling and telecommunications apparatus and located close to rails.*
Conductive housing	Yes
Number of ports	2

* To minimise the risk of interference, a shielded cable is recommended when the cable is located inside 3 m boundary to the rails and connected to this port.

The cable shield should be properly connected (360°) to an earthing point within 1 m from this port. This earthing point should have a low impedance connection to the conductive enclosure of the apparatus cabinet, or similar, where the unit is built-in. This conductive enclosure should be connected to the earthing system of an installation and may be directly connected to the protective earth.

Console	
Electrical specification	LVTTL/LVCMOS-level
Data rate	115.2 kbit/s
Data format	8 data bits, none parity, 1 stop bit, no flow control
Circuit type	SELV
Connection	2.5 mm jack, use Westermo cable 1211-2027

USB	
Electrical specification	USB 2.0 host interface
Data rate	Up to 12 Mbit/s (full-speed mode)
Circuit type	SELV
Maximum supply current	500 mA
Connection	USB receptacle connector type A

I/O / Relay output	
Maximum voltage/current	60 VDC / 80 mA
Connect resistance	Max 30 Ω
Isolation to	All other
Connection	Detachable screw terminal
Connector size	0.2 – 2.5 mm ² (AWG 24 – 13)
I/O / Digital in	
Maximum voltage / load current	60 VDC / 2 mA
Voltage levels	Logic one >12 V, Logic zero <1V
Isolation to	All other
Connection	Detachable screw terminal
Connector size	0.2 – 2.5 mm ² (AWG 24 – 13)
SHDSL	
Electrical specification	ITU-T G.991.2 Annex B
Data rate	32 kbit/s to 30.4 Mbit/s with bonding
Protocol	EFM according to IEEE 802.3-2005
Transmission range	According to ITU-T G.991.2 depending on line quality
Isolation to	All other
Connection	Detachable screw terminal
Connector size	0.2 – 2.5 mm ² (AWG 24 – 13)
Shielded cable	Not required
Number of ports	2

Location of interface ports and LED's

Power connection

(for more details see also page 10)

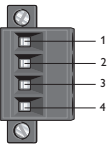
	4-position	Product marking	Direction	Description
	No. 1	+DC1	Input	Supply voltage input DC1
	No. 2	+DC2	Input	Supply voltage input DC2
	No. 3	-COM	Input	Common
	No. 4	-COM	Input	Common

This unit supports redundant power connection. The positive inputs are +DC1 and +DC2, the negative input for both supplies are -COM. Connect the primary voltage (e.g. +24VDC) to the +DC1 pin and return to one of the -COM pins on the power input.

RS-422/485
(for details see page 9 and 14)

LED Indicators
(for details see page 15)

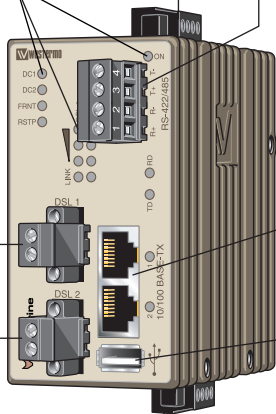

I/O connection
(for details see page 11 and 14)

SHDSL connection (for details see page 11 and 14)

Ethernet connection TX (2 ports)

(for more details see also page 10)

Position	Direction*	Description
No.1	In/Out	Transmitted/Received data
No. 2	In/Out	Transmitted/Received data
No. 3	In/Out	Transmitted/Received data
No. 4	–	Not Connected
No. 5	–	Not Connected
No. 6	In/Out	Transmitted/Received data
No. 7	–	Not Connected
No. 8	–	Not Connected

* Direction relative this unit.

USB

(for more details see also page 10)

Position	Direction*	Description
No.1	Out	VBUS
No. 2	In/Out	D-
No. 3	In/Out	D+
No. 4	Out	GND
Shield	–	Connected to protective earth

* Direction relative this unit.

DDW-142-485 is equipped with internal termination that is configurable through software in RS-422/485 mode. The following termination schemes are supported:

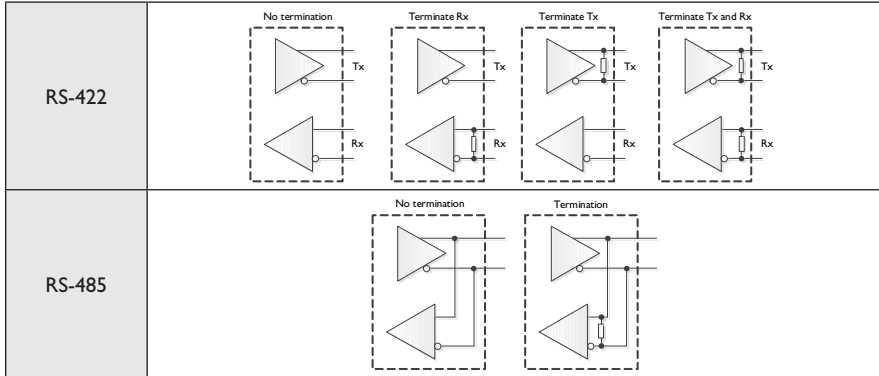

When the unit is powered-off or during reboot, any internal termination will be disconnected from the signal lines.

Note: There are no fail-safe biasing available for RS-422/485 signals.

Console port

(for more details see also page 10)

Position	Direction* / description
No.1	GND
No. 2	Out / Tx
No. 3	In / Rx

* Direction relative to this unit.

I/O connection (for details see page 11 and 14)

Connection to console port

The console port can be used to connect to the CLI (Command Line Interface).

The following steps needs to be taken

1. Connect the serial diagnostic cable to the console port (use only Westermo cable 1211-2027).
2. Connect cable to your computer (USB port, if drivers are needed they can be downloaded from our Web page).
3. Use a terminal emulator and connect with correct speed and format (115200, 8N1) to the assigned port.

For more information about the CLI, see the WeOS management guide.

Cable 1211-2027

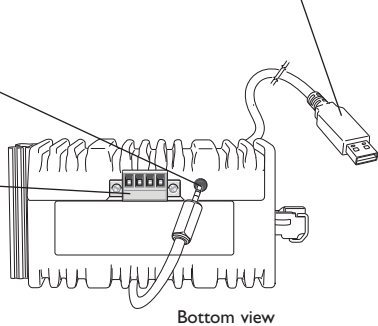

Bottom view

Accessories	
Description	Art no
Westermo console cable	1211-2027

RS-422/485

Position	Signal		Direction	Description	Product marking
	RS-422 (4-wire)	RS-485 (2-wire)			
No. 1	R+	–	In	RS-422: Receive	R+
No. 2	R–	–	In	RS-422: Receive	R–
No. 3	T+	T+/R+	Out/In	RS-422: Transmit RS-485: Transmit/Receive	T+
No. 4	T–	T–/R–	Out/In	RS-422: Transmit RS-485: Transmit/Receive	T–

SHDSL

Position	Direction*	Description
No.1	In/Out	2-wire Receive/Transmit SHDSL
No. 2	In/Out	2-wire Receive/Transmit SHDSL

* Direction relative this unit.

I/O connection

4-position	Product marking	Direction	Description
No. 1	Status +	Output	Alarm relay (status) contact
No. 2	Status –	Output	Alarm relay (status) contact
No. 3	Digital in +	Input	Digital in +
No. 4	Digital in –	Input	Digital in –

The Status output is a potential free, opto-isolated normally closed solid-state relay. This can be configured to monitor various alarm events within the unit, see WeOS Management Guide. An external load in series with an external voltage source is required for proper functionality. For voltage/current ratings, see Interface Specification section.

The Digital in is an opto-isolated digital input which can be used to monitor external events. For voltage/current ratings, see Interface Specification section:

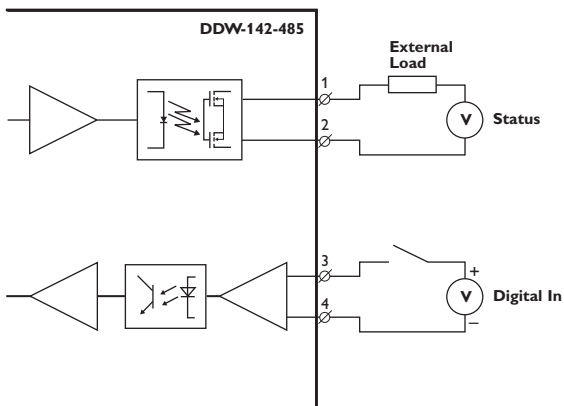

LED indicators

LED	Status	Description
ON	OFF	Unit has no power.
	GREEN	All OK, no alarm condition.
	RED	Alarm condition, or until unit has started up. (Alarm conditions are configurable, see WeOS Management Guide).
	FLASH	Location indicator ("Here I am!"). Activated when connected to IPConfig Tool, or upon request from Web or CLI.
DC1	OFF	Unit has no power.
	GREEN	Power OK on DC1.
	RED	Power failure on DC1.
DC2	OFF	Unit has no power.
	GREEN	Power OK on DC2.
	RED	Power failure on DC2.
FRNT	OFF	FRNT disabled.
	GREEN	FRNT OK.
	RED	FRNT Error.
	BLINK	Unit configured as FRNT focal point.
RSTP	OFF	RSTP disabled.
	GREEN	RSTP enabled.
	BLINK	Unit elected as RSTP/STP root switch.
USR1 (only DDW-242-285)	OFF	Configurable, see WeOS Management Guide.
	GREEN	
	RED	
LNK SHDSL ports Link indicator Port 1–2	OFF	No DSL link.
	GREEN	DSL link established.
	GREEN FLASH	DSL link negotiation.
	YELLOW	Port alarm and no link. Or if FRNT or RSTP mode, port is blocked.
SHDSL ports Quality indicator Port 1–2	All OFF	No DSL link.
	3 RED	Signal to noise value below 3 dB. Unstable DSL link.
	1 GREEN	Signal to noise value 3–5 dB. Marginal DSL link.
	2 GREEN	Signal to noise value 6–9 dB. Normal DSL link.
	3 GREEN	Signal to noise value above 9 dB. Strong DSL link.
RD	OFF	No serial data received.
	GREEN FLASH	Serial data received.
TD	OFF	No serial data transmitted.
	GREEN FLASH	Serial data transmitted.
	YELLOW FLASH	Indicate error on RS-422/485 bus.
Copper ports Port 1–2	OFF	No link.
	GREEN	Link established.
	GREEN FLASH	Data traffic indication.
	YELLOW	Port alarm and no link. Or if FRNT, RSTP or Link Aggregation mode, port is blocked.

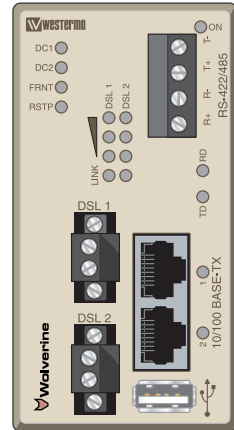

DDW-142-485

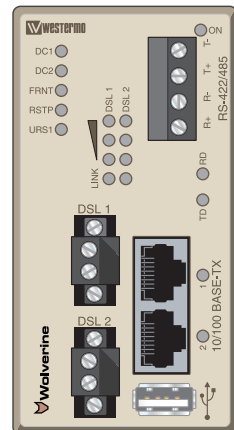

DDW-242-485

Mounting

This unit should be mounted on 35 mm DIN-rail, which is horizontally mounted inside an apparatus cabinet or similar. It is recommended that the DIN-rail is connected to ground. Snap on mounting, see figure.

Mounting the product with integrated DIN-clip:

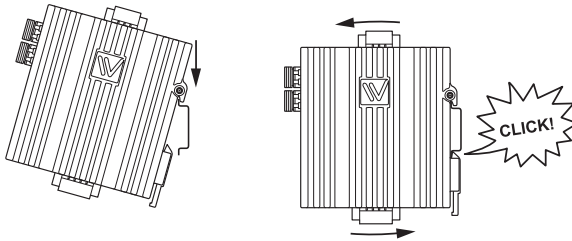

Removal

Removing the product with integrated DIN-clip:
Press down the support at the back of the unit using a screwdriver. See figure.

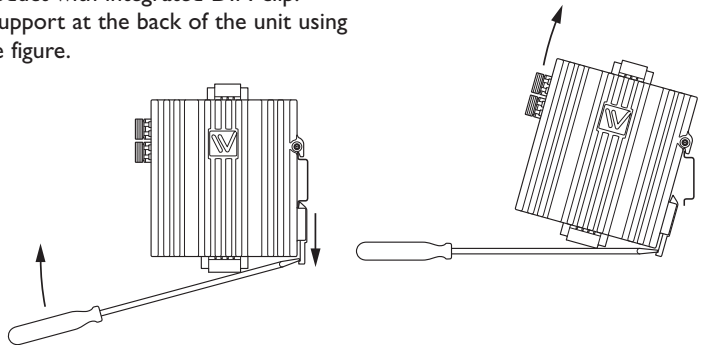

Cooling

This unit uses convection cooling. To avoid obstructing the airflow around the unit, use minimum spacing 25 mm (1.0") above/below and 10 mm (0.4") left/right the unit.

Spacing is recommended for the use of unit in full operating temperature range and service life. When this unit is operated at an ambient temperature above +60°C (+140°F), refer to the Safety warnings on page 3.

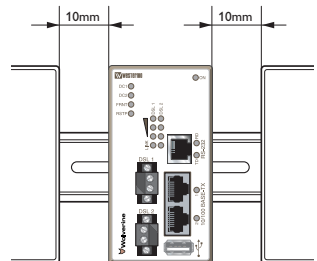

Getting Started

This product runs Westermo Operating System (WeOS) which provides several management tools that can be used for configuration of the unit.

- **IPConfig tool**
This is a custom Westermo tool used for discovery of attached Westermo units.
- **Web**
Configuration of the unit using the web browser.
- **CLI**
Configuration of the unit via the Command Line Interface.

If the computer is located in the same subnet as the switch you can easily use a web browser to configure the unit. Within the web you can configure most of the available functions.

For advanced network settings and more diagnostic information, please use the CLI. Detailed documentation is available in the chapter "The Command Line Management Tool" in the WeOS management guide.

Factory default *IP address:* 192.168.2.200
 Netmask: 255.255.255.0
 Gateway: Disabled

Note! If you are not sure about the subnet – consult your network administrator.

Configuration

Configure the unit via web browser

The unit can easily be configured via a web browser. Open the link <http://192.168.2.200> in your web browser, and you will be prompted with a Login screen, where the default settings for Username and Password are:

Username: admin

Password: westermo

Once you have logged in, you can use the extensive integrated help function describing all configuration options. Two common task when configuring a new switch is to assign appropriate IP settings, and to change the password of the admin account. The password can be up to 64 characters long, and should consist of printable ASCII characters (ASCII 33-126); 'Space' is not a valid password character.

Referring documents

Type	Description	Document number
Management Guide	Westermo OS management guide	6101-3201

Cable factory reset on DDW-142-485 and DDW-242-485

It is possible to set the unit to factory default settings by using a standard Ethernet RJ-45 cable.

1. Power off the unit and disconnect all cables.
2. Connect an Ethernet cable between Ethernet ports 1 and 2. The unit needs to be connected directly by an Ethernet cable i.e., not via a hub or switch. Use a straight cable – not a cross-over cable, when connecting the ports.
3. Power on the unit.
4. Wait for the unit to start-up. Control that the ON LED is flashing red. The ON LED flashing indicates that the unit is now ready to be reset to factory default. You now have the choice to go ahead with the factory reset, or to skip factory reset and boot as normal.
 - Go ahead with factory reset:
Acknowledge that you wish to conduct the factory reset by unplugging the Ethernet cable. The ON LED will stop flashing. This initiates the factory reset process*, and the unit will restart with factory default settings. When the switch has booted up, the ON LED will show a green light, and is now ready to use.
 - Skip the factory reset:
To skip the factory reset process, just wait for approximately 30 seconds (after the ON LED starts flashing RED) without unplugging the Ethernet cable. The switch will conduct a normal boot with the existing settings.

* **Note** Do not power off the unit while the factory reset process is in progress.

Dimensions

Measurements are stated in millimeters.

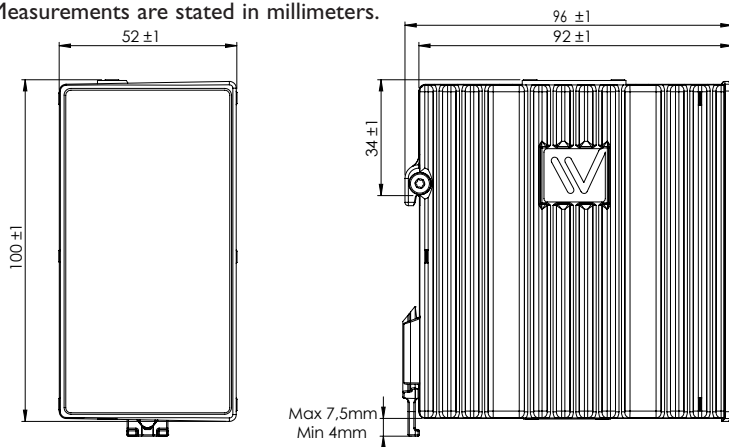



Westermo • SE-640 40 Stora Sundby, Sweden
Tel +46 16 42 80 00 Fax +46 16 42 80 01
E-mail: info@westermo.com
www.westermo.com