

Advanced Industrial Ethernet Extender DDW-242

- ⌘ Save time and money reusing old cable and equipment
 - Up to 15.3 Mbit/s Ethernet over twisted pair or 30.6 Mbit/s with bonding
 - Advanced WeOS layer 3 functionality
 - Legacy connection via RS-232 port
- ⌘ Security, legacy resilient networking from WeOS
 - Network IP Security and remote access
 - Port access control and firewall
 - VPN tunnels over SHDSL
- ⌘ Easy to Use
 - Basic installation with no configuration needed
 - Web screen for simple configuration and CLI for professional use
 - USB fluid configuration for easy maintenance
- ⌘ Robustly designed for mission critical applications
 - 437,000 hours MTBF to MIL- HDBK -217F for extreme reliability
 - Extensive line diagnostics and fault I/O contact and SNMPv3
 - Robust design for vibration, temperature and dual power input



EN 61000-6-1
Residential Immunity

EN 61000-6-2
Industrial Immunity

EN 61000-6-3
Residential Emission

EN 61000-6-4
Industrial Emission

EN 50121-4
Railway Trackside

NEMA TS 2
Traffic Controller Assemblies
with NTCIP Requirements

Westermo's Ethernet extender technology based on SHDSL makes it possible to reuse many types of pre-existing copper cables, which can lead to considerable financial savings when installing new systems. DDW-242 allows effective Ethernet networks to be created over long distances (up to 15 km (9.3 mi)) at data rates up to 15.3 Mbit/s on a single twisted pair cable. By using two pairs "bonded" this rate can be doubled up to 30.6 Mbit/s. The integral switch allows 2 Ethernet devices to be attached and an RS-232 port allows for a legacy piece of equipment to be incorporated into the IP network.

The WeOS (Westermo Operating Systems) has been developed to allow cross platform and future proof solutions. WeOS can deliver unique security functionality for this class of product as well as allowing the DDW-242 to form part of a resilient multimedia ring network using the Westermo FRNT protocol or industry standard STP/RSTP. WeOS has been developed to provide industrial networking solutions and contains amazing serial connectivity capability – from being able to simulate an old AT modem, convert Modbus RTU to TCP or encapsulate serial data into an IP packet. The DDW-242 is incredibly flexible and easy to use. A basic point-to-point or multidrop network can be created without the need for any kind of configuration.

The DDW-242 is often used in applications on railways, roads or with utilities where failure could result in significant costs. All Westermo products are designed with high MTBF in mind to improve operational reliability and also give long service life. Even features like the SHDSL diagnostics and management allow indication of line degradation allowing planned maintenance. As the unit is designed for these applications Westermo also ensure that testing is carried out to ensure the unit can operate at extremes of temperature, EMC and vibration and still provide robust communications.

Ordering Information

Art.no	Description
3642-0320	DDW-242 Industrial Ethernet Extender
3642-0420	DDW-242-12VDC Industrial Ethernet Extender
1211-2027	Diagnostic cable (Console) (Accessories)
3125-0001	PS-30, Power supply, DIN mounted (Accessories)

Specifications DDW-242

Dimensional drawing

Dimension W x H x D 52 x 100 x 101 mm
(2.04 x 3.93 x 3.97 in)
Weight 0.8 kg
Degree of protection IP40

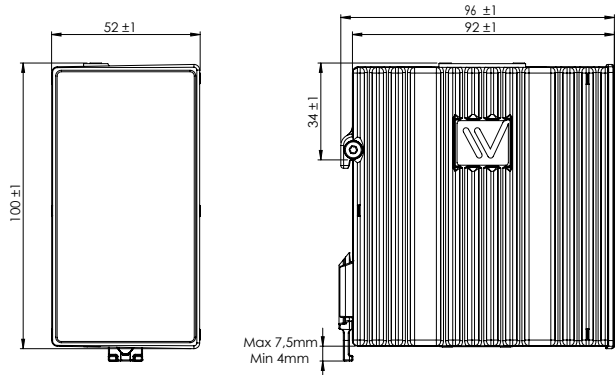

Power		
DDW-242	Rated voltage	24 to 48 VDC
	Operating voltage	19 to 60 VDC
	Rated current	245 mA (405 mA) @ 24 VDC (with 500 mA USB load) 124 mA (200 mA) @ 48 VDC (with 500 mA USB load)
DDW-242-12VDC	Rated voltage	12 to 48 VDC
	Operating voltage	9.8 to 60 VDC
	Rated current	475 mA (765 mA) @ 12 VDC (with 500 mA USB load) 245 mA (405 mA) @ 24 VDC (with 500 mA USB load) 124 mA (200 mA) @ 48 VDC (with 500 mA USB load)

Interfaces	
Ethernet TX	2 x RJ-45, 10 Mbit/s, 100 Mbit/s, manual or auto
SHDSL	2 x 2-position detachable screw terminal
RS-232	1 x RJ-45, 300 bit/s – 115.2 kbit/s
Digital I/O	1 x 4-position detachable screw terminal
USB	1 x USB 2.0 host interface
Console	1 x 2.5 mm jack, use only Westermo cable 1211-2027

Temperature	
Operating	DDW-242: -40 to +70°C (-40 to +158°F)
	DDW-242-12VDC: -40 to +74°C (-40 to +165°F)
Storage & Transport	-40 to +85°C (-40 to +185°F)

Agency approvals and standards compliance	
EMC	EN 61000-6-1, Immunity residential environments
	EN 61000-6-2, Immunity industrial environments
	EN 61000-6-3, Emission residential, commercial and light-industrial environments
	EN 61000-6-4, Emission industrial environments
	EN 50121-4, Railway signalling and telecommunications apparatus
	IEC 62236-4, Railway signalling and telecommunications apparatus
Safety	UL/IEC/EN 60950-1, IT equipment
Marine	DNV GL rules for classification – Ships and offshore units**
Environmental	NEMA TS 2, Traffic Controller Assemblies with NTCIP Requirements**

*Only DDW-242

**Only DDW-242-12VDC