

MP2600iec Hardware Manual

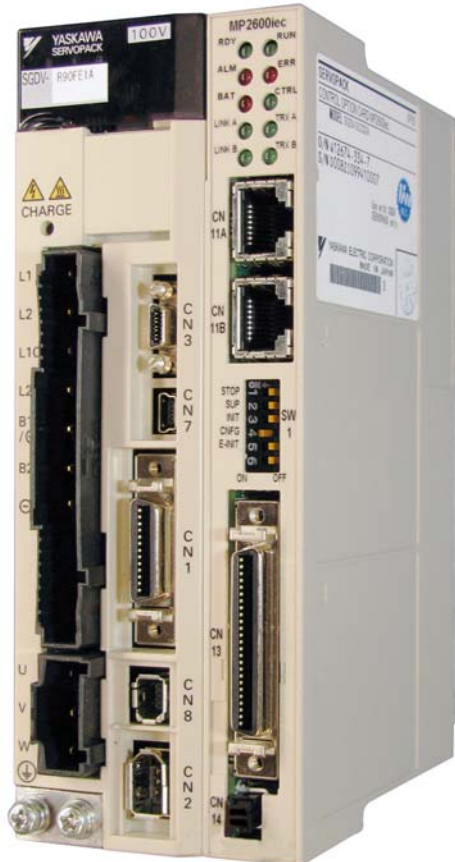

Table of Contents

1 Introduction

1.1 MP2600iec Features	-3
1.2 MP2600iec Appearance	-4
1.3 Model Number Reference	-5

2 Specifications

2.1 General Specifications	-7
2.2 MP2600iec Hardware Specifications	-8

3 Mechanical Installation

3.1 Mounting Information	-9
3.2 Installation Standards	-10
3.3 Dimensions	-11

4 Inputs/Outputs

4.1 CN13 Connection Diagram	-13
4.2 CN13 Connection Description	-14
4.3 External Encoder Interface	-15
4.4 Controller Digital I/O	-16
4.5 Sigma-5 / Sigma-7 I/O	-18
4.6 Analog I/O	-19

5 DIP Switches

5.1 Switch Settings	-21
---------------------	-----

6 LED Outputs

7 Battery

7.1 Battery Installation	-25
--------------------------	-----

8 Ethernet

8.1 Connectivity Information -----27

8.2 Ethernet Connector Details -----27

8.3 Ethernet Cable -----28

8.4 Ethernet Connection Examples -----28

9 Cable Diagrams

9.1 CBK-U-MP2B-xx (Controller Terminal Block) -----31

9.2 CFC-U-MP2B-xx (Controller Flying Lead) -----32

9.3 SBK-U-VBA-xx (Servo Amp Terminal Block) -----33

9.4 JZSP-CSI02-x-E (Servo Amp Flying Lead) -----34

10 Firmware Upgrade Procedure ----- 35

11 EMC Installation Conditions ----- 37

1 Introduction

1.1 MP2600iec Features

MP2600iec is a single-axis machine controller option card that is attached to a Sigma-5 or Sigma-7* servo amplifier. The servo amplifier and controller are factory assembled, providing a compact, all-in-one servo/controller package with the following features:

- PLCopen for Motion Control, including indexing, camming, gearing, and servo parameter maintenance capability.

- Sigma-5/Sigma-7 self-tuning, anti-vibration, and other high performance, easy-to-implement servo control features

- Ethernet (100Mbps) Auto crossover switching
 - EtherNet/IP
 - Modbus TCP
 - Allows high-speed communications with MotionWorks IEC
 - Enables communication with the application program by using a touch panel
 - Enables communication with the application program from another controller

- Combined Amplifier/Controller I/O features
 - 15 digital inputs
 - 11 digital outputs
 - 1 analog input
 - 1 analog output
 - 1 external encoder (quadrature, pulse + direction, up/down)
 - 1 external encoder latch

* MP2600iec is only compatible with single axis, 200V Sigma-7 amplifiers.

1.2 MP2600iec Appearance

The following figure shows the external appearance of the MP2600iec controller (Note: The servo amplifier is not shown).

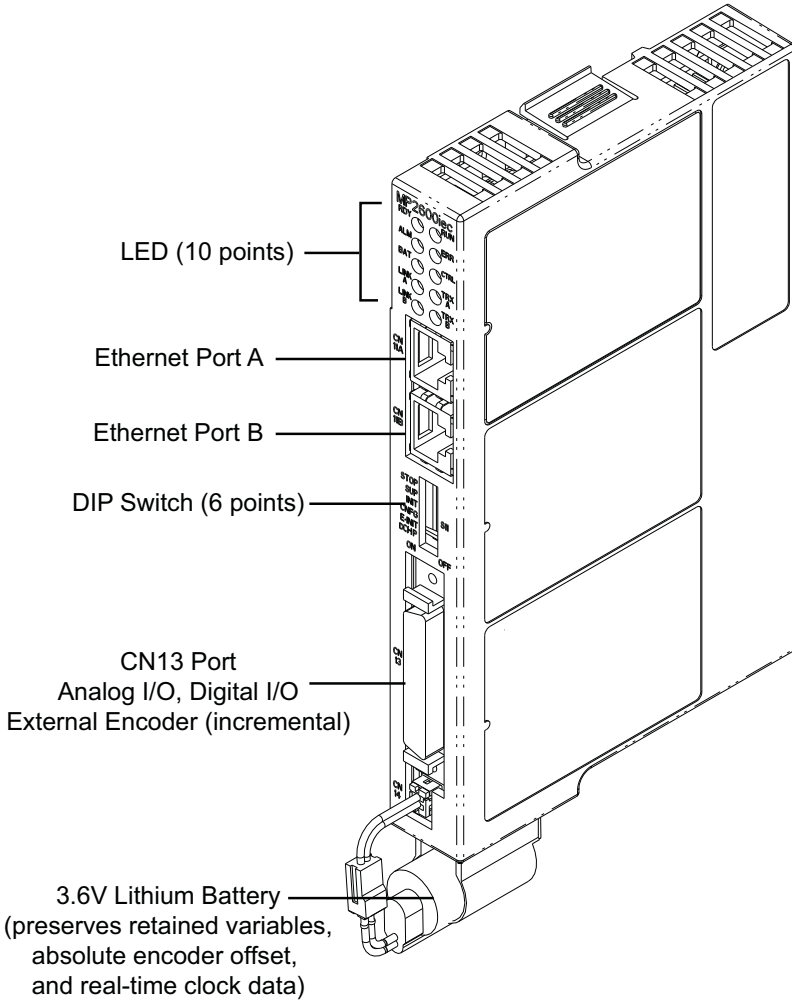

1.3 Model Number Reference

1.3.1 Sigma-5 Model Number Designation

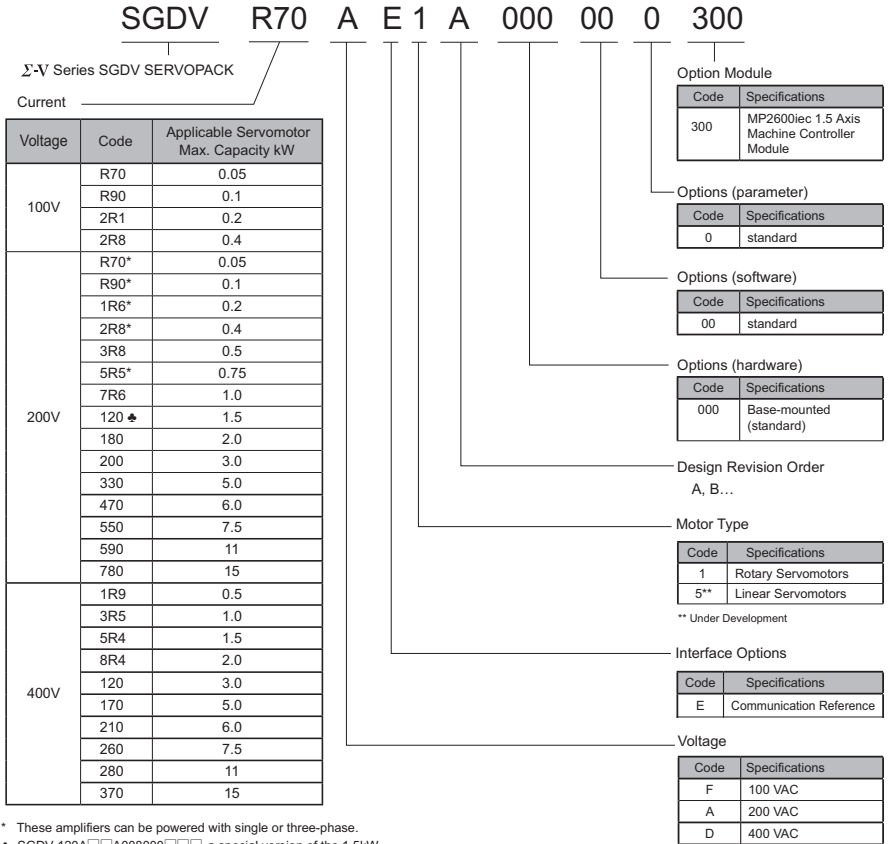

1.3 Model Number Reference

1.3.2 Sigma-7 Model Number Designation

1.3.2 Sigma-7 Model Number Designation

To order SERVOPACKs with the MP2600iec option, use the following model numbers.

SGD7S^{*1}

Σ-7 Series
SERVOPACK

2R8

1st+2nd+3rd
digits

A

4th
digit

E0

5th+6th
digits

A

7th
digit

000

8th+9th+10th
digits

300

11th+12th+
13th digits

1st+2nd+3rd digits

Maximum Applicable
Motor Capacity

4th digit Voltage

6th+9th+10th digits

Hardware Options
Specification

Voltage	Code	Specification
Three-phase, 200 VAC	R70 ^{*2}	0.05 kW
	R90 ^{*2}	0.1 kW
	1R6 ^{*2}	0.2 kW
	2R8 ^{*2}	0.4 kW
	3R8	0.5 kW
	5R5 ^{*2}	0.75 kW
	7R6	1.0 kW
	120	1.5 kW
	180	2.0 kW
	200	3.0 kW
	330	5.0 kW
	470	6.0 kW
	550	7.5 kW
590	11 kW	
780	15 kW	
Single-phase, 100 VAC	R70	0.05 kW
	R90	0.1 kW
	2R1	0.2 kW
	2R8	0.4 kW

Code	Specification
A	200 VAC
F	100 VAC

5th+6th digits Interface

Code	Specification
E0	Other control architecture type

7th digit Design Revision Order
A: Global design revision

Code	Specification	Applicable Models
000	Without options	All models

11th+12th+13th digits FT/EX Specification

Code	Specification
300	MP2600iec single-axis control option

*1. The model number of a SERVOPACK with an Option is not hyphenated after SGD7S.

*2. You can use these models with either a single-phase or three-phase power supply input.

1.3.3 Accessory Model Numbers

System Components			
Type	Model	Part Number	Note
Accessories/Cables	Battery	JZSP-BA01	Replacement
	Battery Holder Kit	SGDV-OZC02A	Replacement (does not include battery)
	CN13 (MP2600iec) Terminal Block Conversion Kit	CBK-U-MP2Bxx	xx denotes cable length (m) A5 = 0.5 01 = 1 03 = 3
	CN13 (MP2600iec) (Flying Leads)	CFC-U-MP2Bxx	
	CN1 (Servo Amp) Terminal Block Conversion Kit	SBK-U-MP2Bxx	
CN1 (Servo Amp) Cable (Flying Leads)	JZSP-CSI02-x-E	x denotes cable length (m) A = 1 B = 2 C = 3	
Communication	Ethernet Cable	N/A	Use commonly available shielded Ethernet cable
Software	MotionWorks IEC Express	PDE-U-IE□Sx	□ denotes MotionWorks IEC Version C = 1 2 = 2 x denotes number of software licenses A = 1 B = 5 C = 10
	MotionWorks IEC Pro	PDE-U-IE□Px	
	OPC Server	PDE-U-OPCPx	x denotes number of software licenses A = 1 B = 5 C = 10 D = 20

1.3 Model Number Reference

1.3.3 Accessory Model Numbers

2 Specifications

2.1 General Specifications

Item		Specifications
Environmental Conditions	Ambient Operating Temperature	0 to 55°C
	Ambient Storage Temperature	-20°C to +85°C
	Ambient Operating Humidity	90% RH or less (with no condensation)
	Ambient Storage Humidity	90% RH or less (with no condensation)
	Protection Class/ Pollution Degree	Protection class: IP10, Pollution degree: 2 An environment that satisfies the following conditions. <ul style="list-style-type: none"> • Free of corrosive or explosive gases • Free of exposure to water, oil or chemicals • Free of dust, salts or iron dust
	Operating Altitude	1,000 m above sea level or lower
Mechanical Operating Conditions	Vibration Resistance	4.9 m/s ²
	Shock Resistance	19.6 m/s ²
	Others	Free of static electricity, strong electromagnetic fields, magnetic fields or exposure to radioactivity

2.2 MP2600iec Hardware Specifications

Item		Specification		
CPU		200 MHz, 32 bit, ARM 9		
Memory	SDRAM		32 MB	
	SRAM		512 kB with battery backup	
	Flash		4 MB flash. Code and parameter storage.	
Operator interface		LED	10 LEDs (red and green - operating mode, communication and error status)	
		User Configuration	6x DIP switch (operating mode and communication configuration)	
User I/O	Controller Side (CN13)	Network		2x 100baseTX Ethernet
		Digital input		8 programmable inputs
		Digital output		8 programmable outputs
		Analog input		1 ch., +/- 10V, 16 bit
		Analog output		1 ch., +/- 10V, 16 bit
		Pulse Counter		RS-422-compatible pulse counter input (quadrature, pulse and direction, and up/down counter modes) with 5, 12, or 24V position latch input
	Servo-Side (CN1)	Sequence Input	Allocated*	Number of Inputs: 7
				Functions: The signal allocation and positive/negative logic can be modified. Forward run prohibited (P-OT), reverse run prohibited (N-OT), forward torque limit (P-CL), reverse torque limit (N-CL), general-purpose input signal (/SI0 to /SI6)
		Sequence Output	Fixed	Servo Alarm (ALM)
				Number of Outputs: 3
			Allocated*	Functions: The signal allocation and positive/negative logic can be modified. Positioning completion (/COIN), speed coincidence detection(/V-CMP), servomotor rotation detection (/TGON), servo ready (/S-RDY), torque limit detection (/CLT), speed limit detection (VLT), brake (/BK), warning (/WARN), near (/NEAR)
Network capability		OPC (Client and Server required)		
		EtherNet/IP		
		Modbus/TCP		
Programming standards		IEC61131-3/PLCopen		
Diagnostic and configuration interface		Web interface		
Motion control performance		1 controlled axis and one external position input at a trajectory update rate of 1 kHz		
Servo-Side Safety Functions		Input	/HWBB1, /HWBB2: Baseblock signal for power module	
		Output	EDM1: Status monitor (fixed output) of built-in safety circuit	

* Allocated I/O can also be used as programmable I/O if the output functions are disabled.

3 Mechanical Installation

3.1 Mounting Information

The MP2600iec controller is pre-assembled to the Sigma-5 or Sigma-7 servo amplifier by the factory.

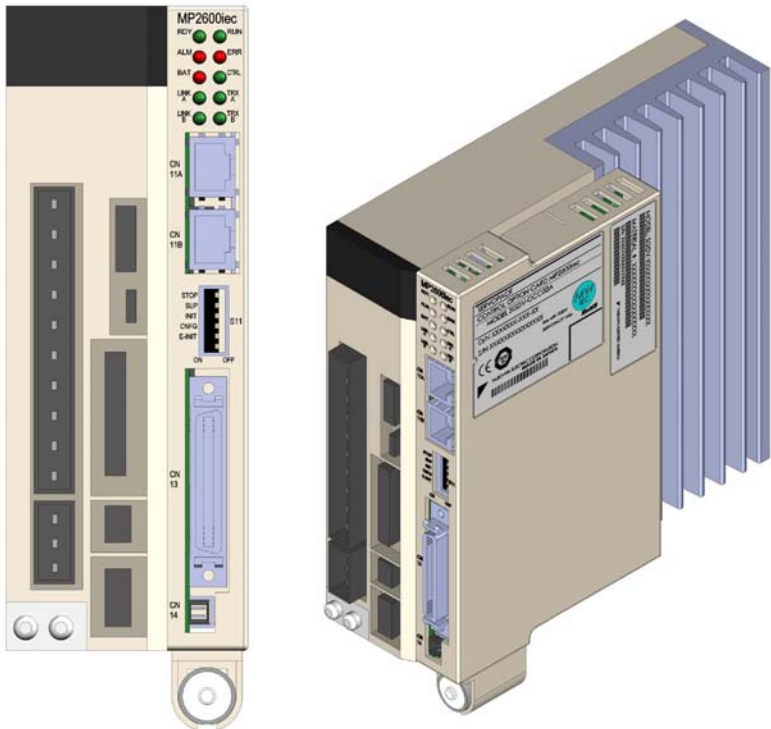

3.2 Installation Standards

The servo amplifier must be installed in a fully enclosed metal control panel. Observe the standards for mounting servo amplifiers in control panels, including those for the mounting servo amplifiers side by side in one control panel as shown in the following illustration.

- Servo Amplifier Mounting Orientation
Mount the servo amplifier vertically to the wall, with the front panel (the side with the panel operator display) facing out.
- Cooling
Refer to the following diagram and leave sufficient space for cooling by fans and natural convection.
- Mounting Servo Amplifiers Side by Side in a Control Panel

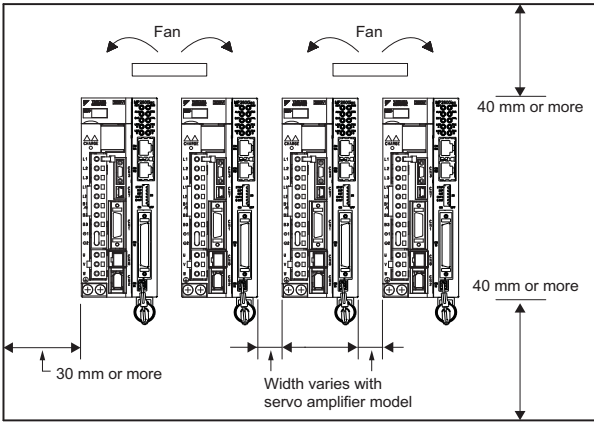

Leave sufficient space on each side and at the top and the bottom of each servo amplifier. The width on each side varies in accordance with the models of the servo amplifiers used.

Servo Amplifier Model for Sigma-5 (SGDV-) or Sigma-7 (SGD7S-)	Side		Top and bottom
	Left	Right	
R70F, R90F, 2R1F, R70A, R90A, 1R6A, 2R8A	1 mm or more		40 mm or more
2R8F, 3R8A, 5R5A, 7R6A	1 mm or more	10 mm or more	
120A, 180A, 200A, 330A, 470A, 550A, 590A, 780A, 1R9D, 3R5D, 5R4D, 8R4D, 120D, 170D, 210D, 260D, 280D, 370D	10 mm or more		

Also install cooling fans above the servo amplifiers to disperse local pockets of warmer air around the servo amplifiers.

- Inside the Control Panel
The conditions inside the control panel should be the same as the environmental conditions of the servo amplifier. Refer to the environmental conditions in 2.1 *General Specifications*
- During Operation
Do not touch the connectors or IO cables during operation if the panel door is open.

3.3 Dimensions

3.3.1 MP2600iec Controller

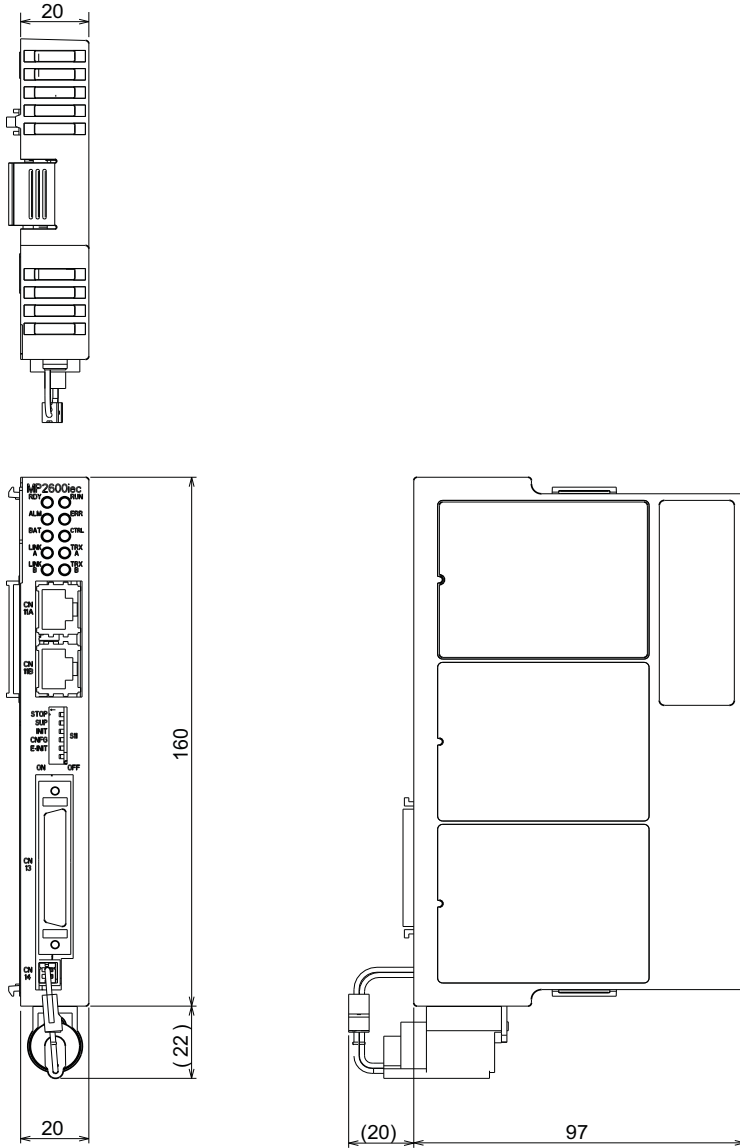

Dimensions in mm.

3.3 Dimensions

3.3.1 MP2600iec Controller

This page left intentionally blank

4 Inputs/Outputs

4.1 CN13 Connection Diagram

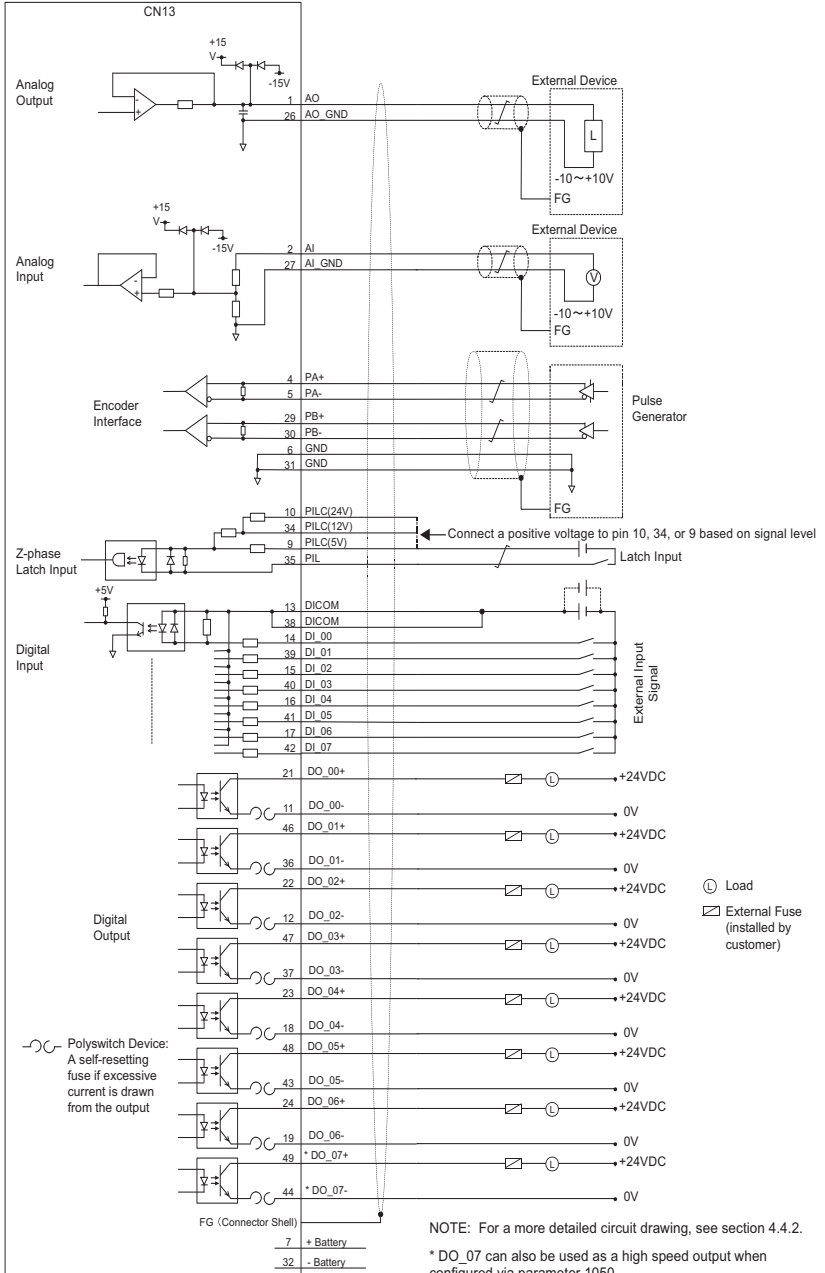

4.2 CN13 Connection Description

Numerical

CN 13 Pin	Code	Description
1	AO	Analog Output
2	AI	Analog Input
3	n/c	no connection
4	PA+	Encoder A phase +
5	PA-	Encoder A phase -
6	GND	Encoder ground
7	BAT +	SRAM Positive Battery input
8	n/c	no connection
9	PILC	PC+ / External Encoder Latch +5V
10	PILC	PC+ / External Encoder Latch +24V
11	DO 00-	Digital Output 0 -
12	DO 02-	Digital Output 2 -
13	DICOM	Digital Input Common
14	DI 00	Digital Input 0
15	DI 02	Digital Input 2
16	DI 04	Digital Input 4
17	DI 06	Digital Input 6
18	DO 04-	Digital Output 4 -
19	DO 06-	Digital Output 6 -
20	n/c	no connection
21	DO 00+	Digital Output 0 +
22	DO 02+	Digital Output 2 +
23	DO 04+	Digital Output 4 +
24	DO 06+	Digital Output 6 +
25	n/c	no connection
26	AO GND	Analog Output Ground
27	AI GND	Analog Input Ground
28	n/c	no connection
29	PB+	Encoder B phase +
30	PB-	Encoder B phase -
31	GND	Encoder ground
32	BAT -	SRAM Negative Battery input
33	n/c	no connection
34	PILC	PC+ / External Encoder Latch +12V
35	PIL	PC- / External Encoder Latch
36	DO 01-	Digital Output 1 -
37	DO 03-	Digital Output 3 -
38	DICOM	Digital Input Common
39	DI 01	Digital Input 1
40	DI 03	Digital Input 3
41	DI 05	Digital Input 5
42	DI 07	Digital Input 7
43	DO 05-	Digital Output 5 -
44	DO 07-	Digital Output 7 -
45	n/c	no connection
46	DO 01+	Digital Output 1 +
47	DO 03+	Digital Output 3 +
48	DO 05+	Digital Output 5 +
49	DO 07+	Digital Output 7 +
50	n/c	no connection

Alphabetical

Description	Code	CN 13 Pin
Analog Input	AI	2
Analog Input Ground	AI GND	27
Analog Output	AO	1
Analog Output Ground	AO GND	26
Digital Input 0	DI 00	14
Digital Input 1	DI 01	39
Digital Input 2	DI 02	15
Digital Input 3	DI 03	40
Digital Input 4	DI 04	16
Digital Input 5	DI 05	41
Digital Input 6	DI 06	17
Digital Input 7	DI 07	42
Digital Input Common	DICOM	13
Digital Input Common	DICOM	38
Digital Output 0 -	DO 00-	11
Digital Output 0 +	DO 00+	21
Digital Output 1 -	DO 01-	36
Digital Output 1 +	DO 01+	46
Digital Output 2 -	DO 02-	12
Digital Output 2 +	DO 02+	22
Digital Output 3 -	DO 03-	37
Digital Output 3 +	DO 03+	47
Digital Output 4 -	DO 04-	18
Digital Output 4 +	DO 04+	23
Digital Output 5 -	DO 05-	43
Digital Output 5 +	DO 05+	48
Digital Output 6 -	DO 06-	19
Digital Output 6 +	DO 06+	24
Digital Output 7 -	DO 07-	44
Digital Output 7 +	DO 07+	49
Encoder A phase -	PA-	5
Encoder A phase +	PA+	4
Encoder B phase -	PB-	30
Encoder B phase +	PB+	29
Encoder ground	GND	6
Encoder ground	GND	31
no connection	n/c	3
no connection	n/c	8
no connection	n/c	20
no connection	n/c	25
no connection	n/c	28
no connection	n/c	33
no connection	n/c	45
no connection	n/c	50
PC- / External Encoder Latch	PIL	35
PC+ / External Encoder Latch+12V	PILC	34
PC+ / External Encoder Latch+24V	PILC	10
PC+ / External Encoder Latch +5V	PILC	9
SRAM Negative Battery input	BAT -	32
SRAM Positive Battery input	BAT +	7

Note: DO_07 can also be used as a high speed output when configured via parameter 1050. See the PLCopen Plus Axis Parameters for more details.

4.3 External Encoder Interface

Item	Specification
Number of channels	One channel (Phase A, Phase B, Index pulse)
Input circuit	Phase A & B: 5V differential input (RS-422 compatible), non-insulated. Maximum frequency 4MHz. Index pulse: 5V/12V/24V photo coupler input. Maximum frequency 500kHz (pre-quadrature). This signal is used for external encoder latch.
Counter modes	Quadrature, pulse and direction, up/down
PIL Latch input	Hardware latency: 5 μ s or less, sinking input
DI_01 Latch Input	Hardware latency: 600 μ s or less, sinking input

Two RS-422 compatible inputs are provided for encoder phases A and B. One position latch input which supports a 5V, 12V, or 24V digital input signal is provided.

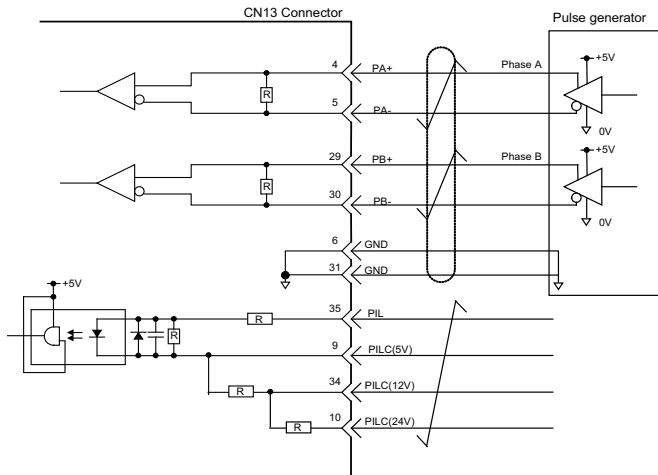

Encoder Input Circuit (PILC refers to positive input side of sensor)

4.4 Controller Digital I/O

4.4.1 Inputs

- 8 general purpose
- Optically isolated
- 24 V @ 5 mA
- Entire bank is configurable as either current sinking or sourcing via connection of common

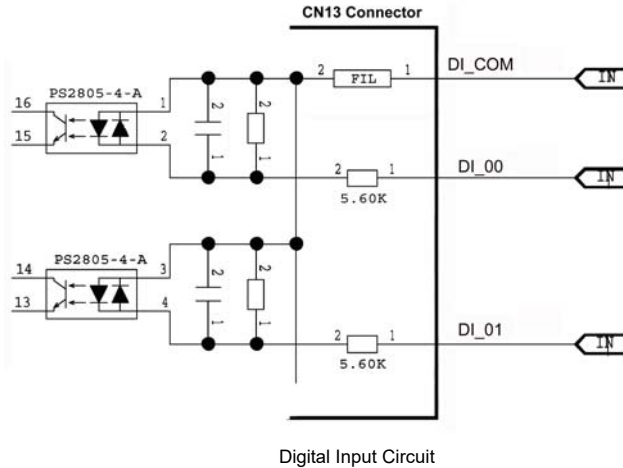

To configure all controller inputs as sinking, wire +24VDC to pins 13 and 38. To configure all controller inputs as sourcing, wire 0VDC to pins 13 and 38. Refer to diagram in Section 5.1.

4.4.2 Outputs

- 8 general purpose
- Optically isolated
- 24 V @ 50 mA
- Current source or sink (connection to both emitter and collector are provided)
- High speed digital output feature can set DO_07 within 13 μ s of passing a specified encoder position. See Axis Parameters in the PLCopen Plus Function Block Manual to configure.

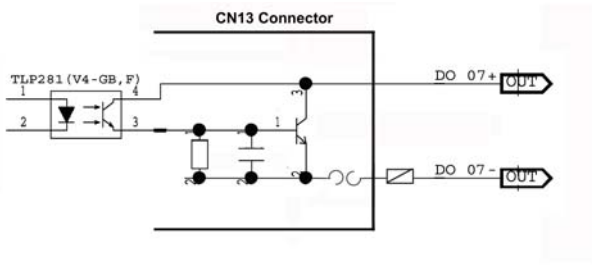

Digital Output Circuit

Connection Examples of Output Circuits

- Relay Circuit Example

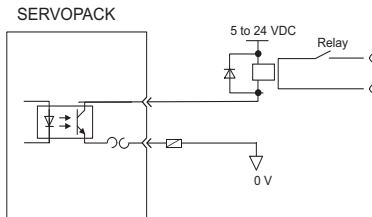

- Line Receiver Circuit Example

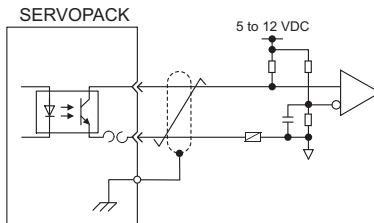

4.5 Sigma-5 / Sigma-7 I/O

Sigma-5 and Sigma-7 SERVOPACKS include seven digital inputs and three digital outputs that can be monitored and controlled by the MP2600iec.

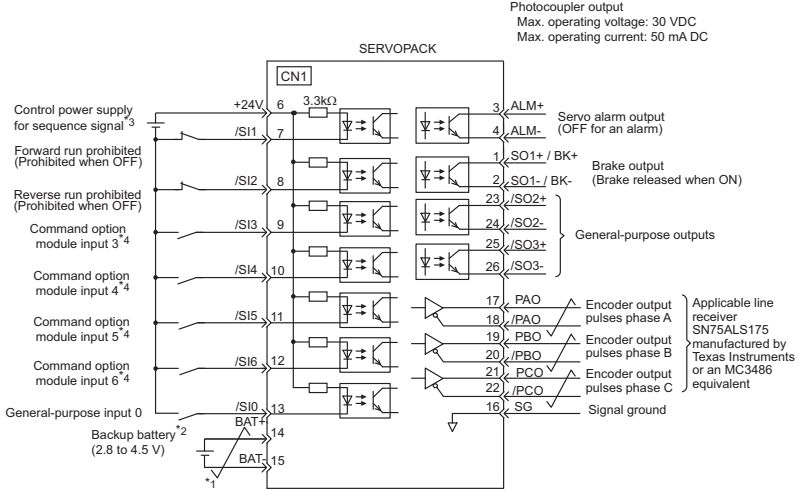

4.6 Analog I/O

4.6.1 Analog Input

Item		Specification
Analog input range		-10V ~ +10V
Number of input channels		1
Electrical isolation		None
Absolute maximum input		$\pm 15V$
Input Impedance		20k Ω
Resolution		16 bit
Accuracy	25°C	$\pm 0.1\%$ ($\pm 10mV$)
	0 ~ 55°C	$\pm 0.3\%$ ($\pm 30mV$)
Input filter	Time constant	$\tau = 130\mu s$ (63.2% rise time)
	Delay time	1ms maximum (for full-range -10V to +10V slew)
Conversion time		50 μs

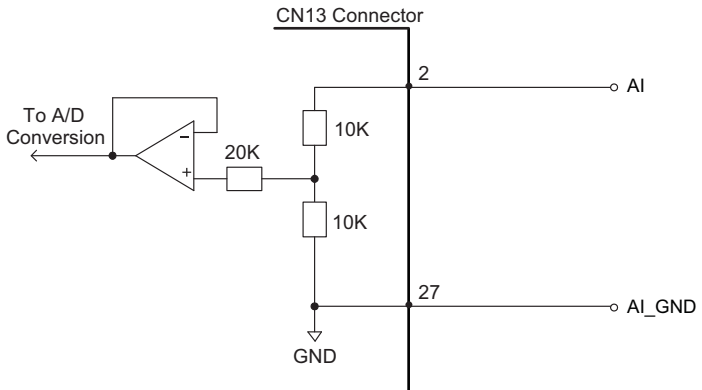

Analog Input Circuit

4.6.2 Analog Output

Item		Specification
Analog output range		-10V ~ +10V
Number of output channels		1
Electrical isolation		None
Maximum load current		± 5mA
Resolution		16 bit
Accuracy	25°C	±0.45% (± 45mV)
	0 ~ 55°C	±0.60% (± 60mV)
Output delay time		less than 1ms

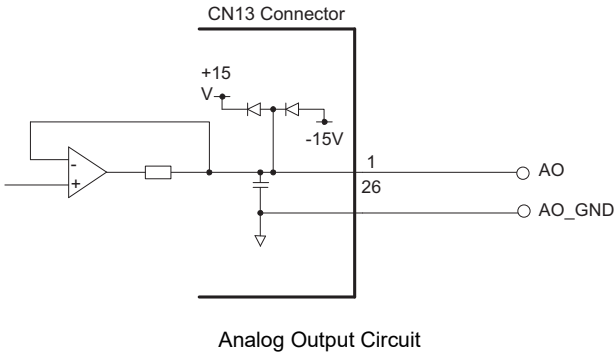

5 DIP Switches

5.1 Switch Settings

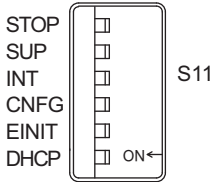

Switch	Name	Setting	Operating Mode	Setting for Normal Operation	Details
1	STOP	ON	User program execution inhibited	OFF	Inhibits user program execution
		OFF	Normal operation		
2	SUP	ON	Firmware programming mode	OFF	Enables controller firmware programming. (See Section 11)
		OFF	Normal operation		
3	INIT	ON	SRAM/clock initialization and configuration bypass	OFF	The INIT switch bypasses the loading of the saved configuration and initializes the SRAM contents and clock settings. Use after backup power has been lost, or if there are configuration issues causing alarms on the controller that may prevent connecting to the MPiec controller. If the INIT switch is ON and the CNFG switch is OFF, the controller will show no axes connected.
		OFF	Normal operation		
4	CNFG	ON	Normal operation	ON	Always set to ON
		OFF	Do not set (reserved for future use)		
5	E-INIT	ON	Force Ethernet address setting for Port A to 192.168.1.1 and Port B to 192.168.2.1	OFF	Enables use of the default Ethernet addresses
		OFF	Normal Operation		
6	DHCP	ON	DHCP-configured IP settings	OFF	Enables use of DHCP for IP setting configuration
		OFF	Manually-configured IP settings		

This page left intentionally blank

6 LED Outputs

The following table shows the indicators that show the operating status of the controller and error information.

	Indicator	Color	Status
	RDY	Green	Lit during normal operation.
	RUN	Green	Lit during execution of user program.
RDY ○ ○ RUN	ALM	Red	Lit when alarm occurs.
ALM ○ ○ ERR	ERR	Red	Lit when malfunction occurs.
BAT ○ ○ CTRL	CTRL	Green	Lit when option card is communicating to the servo amplifier.
LINK A ○ ○ TRX A	BAT	Red	Lit during battery alarm.
LINK B ○ ○ TRX B	TRX A	Green	Lit during Ethernet CN11A activity.
	LINK A	Green	Lit during Ethernet CN11A link up.
	TRX B	Green	Lit during Ethernet CN11B activity.
	LINK B	Green	Lit during Ethernet CN11B link up.

This page left intentionally blank

7 Battery

7.1 Battery Installation

A 3.6V lithium battery must be used to retain SRAM data in the controller when the power is off. SRAM will last for one hour without the battery connected. The battery power can be applied through the battery connector (CN14), or through the I/O connector (CN13 pins 7[+] & 32[-]). The battery is necessary for preserving retained variables, absolute encoder offset, and real-time clock data.

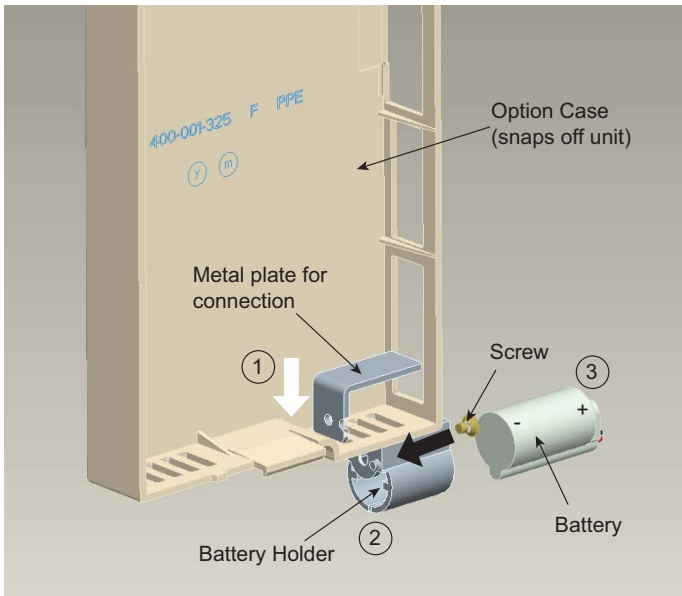

7.2 SRAM Initialization

To initialize the non-volatile memory and clock settings after a battery is attached for the first time (or any time backup power has been lost), use the following procedure.

1. Power off the MP2600iec.
2. Set the "INIT" switch (S11) to ON.
3. Power on the MP2600iec and wait for the "RDY" LED to illuminate.
4. Power off the MP2600iec.
5. Set the "INIT" switch (S11) to OFF.

7.3 Battery Holder Installation Instructions:

	<ol style="list-style-type: none">1. Remove the plastic case from the controller by pressing the tabs at the top and bottom.2. Insert the tab of the metal plate into the last vent slot on the bottom front of the case as shown.3. Line up the hole in battery holder with the hole in the metal plate and secure the battery holder with the screw provided.4. Attach the extension cable to the battery and place the battery into the battery holder with the cable facing forward.5. Attach the plastic case to the controller.6. Plug the battery extension cable into the battery connector (CN14).
---	--

8 Ethernet

8.1 Connectivity Information

The MP2600iec supports 100MB speeds exclusively. Two separate networks are possible using both CN11A and CN11B. A default gateway can be specified only for the network attached to CN11A.

8.2 Ethernet Connector Details

Ethernet Connector Specification and Pin Array

The following table provides the Ethernet connector specifications.

Connector Name	Number of Pins	Connector Model		
		Module Side	Cable Side	Manufacturer
Ethernet	8	RJ-45 CAT5 Socket	RJ-45 CAT5 Plug	Pulse Engineering

The following table provides Ethernet connector pin array / indicator light details.



Pin Number	Signal Name	Description
1	TXD+	Transmitted data + side
2	TXD-	Transmitted data – side
3	RXD+	Received data + side
4	–	–
5	–	–
6	RXD-	Received data – side
7	–	–
8	–	–

8.3 Ethernet Cable

For the Ethernet cable, use a twisted pair cable with RJ-45 connector. Yaskawa strongly recommends the use of shielded ethernet cables. Ethernet ports are capable of auto-crossover, so crossover cables are not necessary.

8.4 Ethernet Connection Examples

Connection Example 1 (When using a repeater HUB)

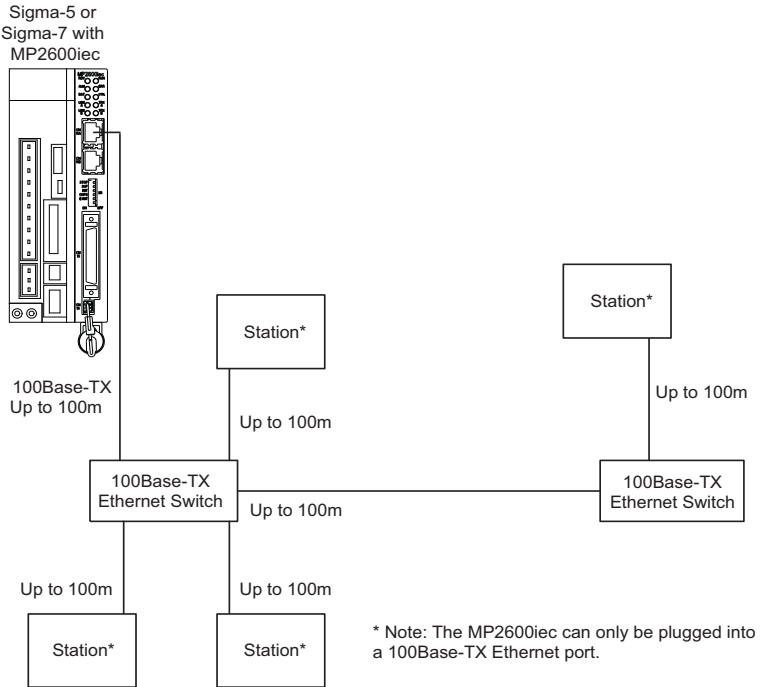

Specification

Item	When Connecting to a Ethernet Switch
Cable Length between Node-HUB	100 m or less
Cable Length between HUBs	100 m or less
Number of HUBs between Nodes	Unlimited

Connection Example 2

Sigma-5 or Sigma-7
with MP2600iec

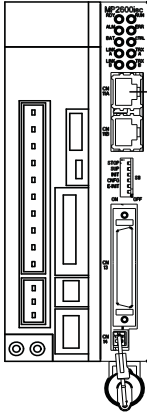

100 Base-TX (up to 100m)



Note: The MP2600iec can only be plugged into a 100Base-TX Ethernet port.

■ Caution

High frequency wave noise from other devices in the installation environment may cause errors in communications. When designing a system, use protective measures to avoid the influence of high frequency wave noise as follows:

1. Wiring

Wire Ethernet cables so that they are well-separated from other cable systems such as the main circuit or power lines.

2. Communication system (Ethernet)

- Communicate data to a remote device.
- Yaskawa strongly recommends shielded Ethernet cables.

3. Attach a ferrite core.

This will help reduce the occurrence of electrical interference.

Recommended ferrite core:

Model	Manufacturer
E04SR301334	Seiwa Electric Mfg. Co., Ltd



Connection Example 3

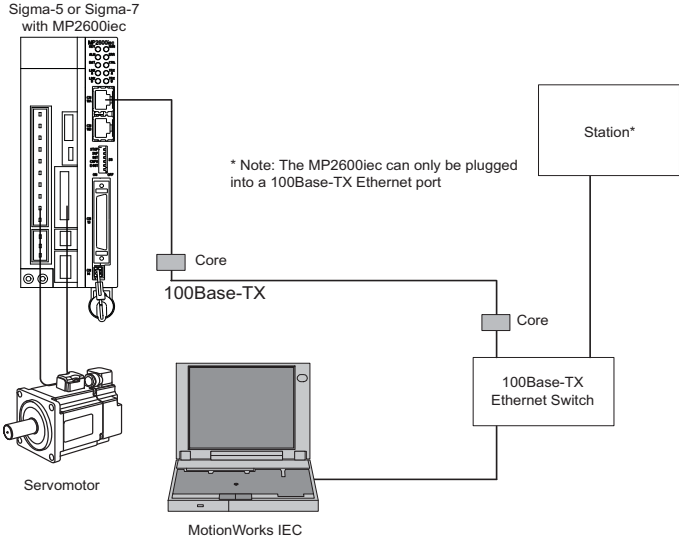

9 Cable Diagrams

9.1 CBK-U-MP2B-xx (Controller Terminal Block)

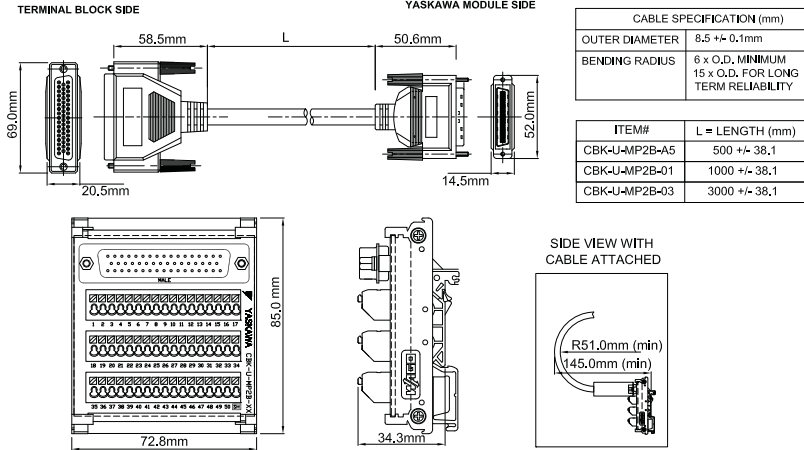

CBK-U-MP2B-XX Function Chart for MP2600iec

Pin No.	Signal Name	I/O	Function	Pin No.	Signal Name	I/O	Function
1	AO	O	Analog output	26	AO_GND	O	Analog output ground
2	AI	I	Analog input	27	AI_GND	I	Analog input ground
3	-	-	-	28	reserved	-	-
4	PA+	I	Phase A pulse (+)	29	PB+	I	Phase B pulse (+)
5	PA-	I	Phase A pulse (-)	30	PB-	I	Phase B pulse (-)
6	GND	P	Encoder input ground	31	GND	P	Encoder input ground
7	BAT+	P	Controller SRAM Battery (+)	32	BAT-	P	Controller SRAM Battery (-)
8	-	-	-	33	-	-	-
9	PILC5V	I	Phase-C latch pulse (-) for 5VDC input	34	PILC12V	I	Phase-C latch pulse (-) for 12VDC input
10	PILC24V	I	Phase-C latch pulse (-) for 24VDC input	35	PIL	I	Phase-C latch pulse (+)
11	DO_00-	O	Digital output 0 (-)	36	DO_01-	O	Digital output 1 (-)
12	DO_02-	O	Digital output 2 (-)	37	DO_03-	O	Digital output 3 (-)
13	DICOM	I	Digital input common	38	DICOM	I	Digital input common
14	DI_00	I	Digital input 0	39	DI_01	I	Digital input 1 (shared with pulse latch input)
15	DI_02	I	Digital input 2	40	DI_03	I	Digital input 3
16	DI_04	I	Digital input 4	41	DI_05	I	Digital input 5
17	DI_06	I	Digital input 6	42	DI_07	I	Digital input 7
18	DO_04-	O	Digital output 4 (-)	43	DO_05-	O	Digital output 5 (-)
19	DO_06-	O	Digital output 6 (-)	44	DO_07-	O	Digital output 7 (-)
20	-	-	-	45	-	-	-
21	DO_00+	O	Digital output 0 (+)	46	DO_01+	O	Digital output 1 (+)
22	DO_02+	O	Digital output 2 (+)	47	DO_03+	O	Digital output 3 (+)
23	DO_04+	O	Digital output 4 (+)	48	DO_05+	O	Digital output 5 (+)
24	DO_06+	O	Digital output 6 (+)	49	DO_07+	O	Digital output 7 (+) (shared with position agreement 'COIN' signal)
25	-	-	-	50	-	-	-

I = Input, O = Output, P = Power

9.2 CFC-U-MP2B-xx (Controller Flying Lead)

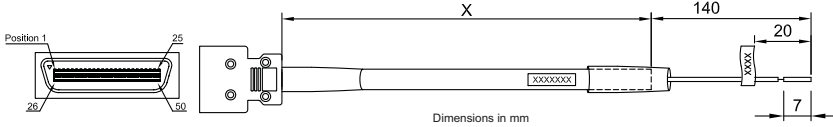

Model	X = Cable Length
CFC-U-MP2B-A5	500 mm
CFC-U-MP2B-01	1000 mm
CFC-U-MP2B-03	3000 mm

CABLE SPECIFICATION (mm)	
OUTER DIAMETER	8.1
BENDING RADIUS	12 O.D.

CFC-U-MP2B-xx I/O Pinout for MP2600Iec

Pin No.	Color (Solid/Band)	Signal Name	I/O	Function	Pin No.	Color (Solid/Band)	Signal Name	I/O	Function
1	BLK/RED	AO	O	Analog output	26	RED/BLK	AO_GND	O	Analog output ground
2	BLK/WHT	AI	I	Analog input	27	WHT/BLK	AI_GND	I	Analog input ground
3	RED/GRN	-	-	-	28	GRN/RED	-	-	-
4	BLK/BLK	PA+	I	Phase A pulse (+)	29	BLK/BRN	PB+	I	Phase B pulse (+)
5	BLU/BLK	PA-	I	Phase A pulse (-)	30	BRN/BLK	PB-	I	Phase B pulse (-)
6	RED/BLU	GND	P	Encoder input ground	31	BLU/RED	GND	P	Encoder input ground
7	RED/WHT	BAT+	P	Controller SRAM Battery (+)	32	WHT/RED	BAT-	P	Controller SRAM Battery (-)
8	BLK/GRN	-	-	-	33	GRN/BLK	-	-	-
9	BLK/YEL	PILC5V	I	Phase-C latch pulse (-) for 5VDC input	34	ORG/BLK	PILC12V	I	Phase-C latch pulse (-) for 12VDC input
10	BLK/ORG	PILC24V	I	Phase-C latch pulse (-) for 24VDC input	35	YEL/BLK	PIL	I	Phase-C latch pulse (+)
11	RED/YEL	DO_00-	O	Digital output 0 (-)	36	WHT/ORG	DO_01-	O	Digital output 1 (-)
12	RED/BRN	DO_02-	O	Digital output 2 (-)	37	BLU/YEL	DO_03-	O	Digital output 3 (-)
13	RED/ORG	DICOM	I	Digital input common	38	ORG/RED	DICOM	I	Digital input common
14	GRN/WHT	DI_00	I	Digital input 0	39	WHT/GRN	DI_01	I	Digital input 1 (shared with pulse latch input)
15	GRN/BLU	DI_02	I	Digital input 2	40	BLU/GRN	DI_03	I	Digital input 3
16	GRN/YEL	DI_04	I	Digital input 4	41	YEL/GRN	DI_05	I	Digital input 5
17	GRN/BRN	DI_06	I	Digital input 6	42	BRN/GRN	DI_07	I	Digital input 7
18	GRN/ORG	DO_04-	O	Digital output 4 (-)	43	BLU/BRN	DO_05-	O	Digital output 5 (-)
19	WHT/BLU	DO_06-	O	Digital output 6 (-)	44	BLU/ORG	DO_07-	O	Digital output 7 (-)
20	WHT/YEL	-	-	-	45	YEL/WHT	-	-	-
21	YEL/RED	DO_00+	O	Digital output 0 (+)	46	ORG/WHT	DO_01+	O	Digital output 1 (+)
22	BRN/RED	DO_02+	O	Digital output 2 (+)	47	YEL/BLU	DO_03+	O	Digital output 3 (+)
23	ORG/GRN	DO_04+	O	Digital output 4 (+)	48	BRN/BLU	DO_05+	O	Digital output 5 (+)
24	BLU/WHT	DO_06+	O	Digital output 6 (+)	49	ORG/BLU	DO_07+	O	Digital output 7 (+) (shared with position agreement 'COIN' signal)
25	WHT/BRN	-	-	-	50	BRN/WHT	-	-	-

(I = Input, O = Output, P = Power)

9.3 SBK-U-VBA-xx (Servo Amp Terminal Block)

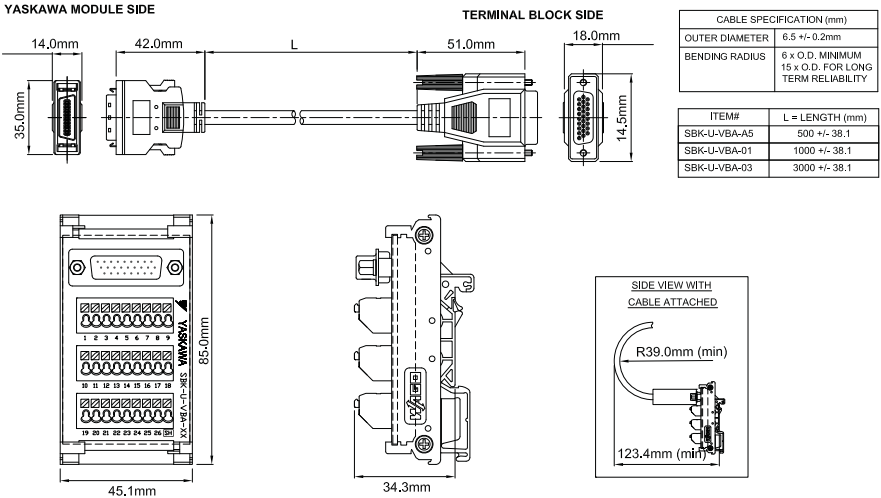

SBK-U-VBA-xx Function Chart for Sigma-5 or Sigma-7 Servo Amplifier

Pin No.	Mechatrolink-II type Servo Amplifier / Option type	
	Signal	Function
1	/BK+ (/SO1+)	Brake interlock output (+) (General purpose output 1 (+))
2	/BK- (/SO1-)	Brake interlock output (-) (General purpose output 1 (-))
3	ALM+	Servo alarm output (+)
4	ALM-	Servo alarm output (-)
5	-	
6	+24VIN	Control power supply for sequence signal input
7	P-OT (/SI1)	Forward run prohibited input (General purpose input 1)
8	N-OT (/SI2)	Reverse run prohibited input (General purpose input 2)
9	/DEC (/SI3)	Zero-point return deceleration switch input (General purpose input 3)
10	/EXT1 (/SI4)	External latch signal 1 input (General purpose input 4)
11	/EXT2 (/SI5)	External latch signal 2 input (General purpose input 5)
12	/EXT3 (/SI6)	External latch signal 3 input (General purpose input 6)
13	/SI0	General purpose input 0
14	BAT (+)	Battery (+) input
15	BAT (-)	Battery (-) input
16	SG	Signal ground
17	PAO	Phase-A pulse output (+)
18	/PAO	Phase-A pulse output (-)
19	PBO	Phase-B pulse output (+)
20	/PBO	Phase-B pulse output (-)
21	PCO	Phase-C pulse output (+)
22	/PCO	Phase-C pulse output (-)
23	/SO2+	General purpose output 2 (+)
24	/SO2-	General purpose output 2 (-)
25	/SO3+	General purpose output 3 (+)
26	/SO3-	General purpose output 3 (-)

Note: General purpose input and output signals are shown with their default signals assigned - signal assignment may have been changed by parameter

9.4 JZSP-CSI02-x-E (Servo Amp Flying Lead)

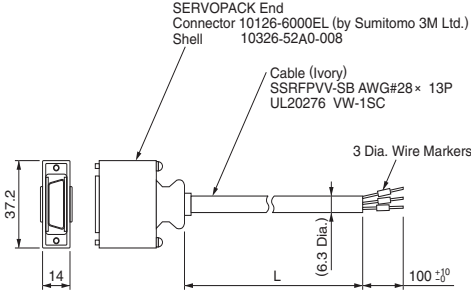

Dimensions in mm

Model	Cable Length
JZSP-CSI02-1-E	1000 mm
JZSP-CSI02-2-E	2000 mm
JZSP-CSI02-3-E	3000 mm

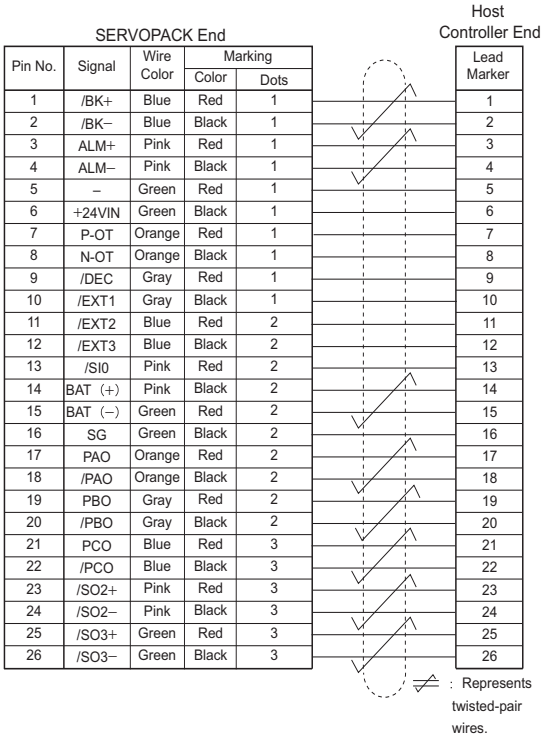

10 Firmware Upgrade

It is possible to upgrade the Controller firmware in the field.

For detailed instructions, please refer to Product Note PN.MCD.08.083: Upgrading the MP2□□□iec Controller Firmware. This document may be downloaded from our website, www.yaskawa.com.

This page left intentionally blank

11 EMC Installation Conditions

This section describes the recommended installation conditions that satisfy EMC guidelines for each model of the SERVOPACK. The conditions required for the standard type (base-mounted) of the SERVOPACK are described. Refer to this section for other SERVOPACK models such as the rack-mounted types as well.

This section describes the EMC installation conditions satisfied in test conditions prepared by Yaskawa. The actual EMC level may differ depending on the actual system's configuration, wiring, and other conditions. However, because this product is built-in, check that the following conditions are still met after being installed in the user's product.

The applicable standards are EN55011/A2 group 1 class A, EN61800-3, and EN61000-6-2.

Ethernet Communication Cables: Use a category 5 or higher cable with double, aluminum tape and braided shielding according to the standard EN50288-2-2.

Single-phase 100 V
 Models R70, R90, 2R1, 2R8 + SGDV-OCC02A

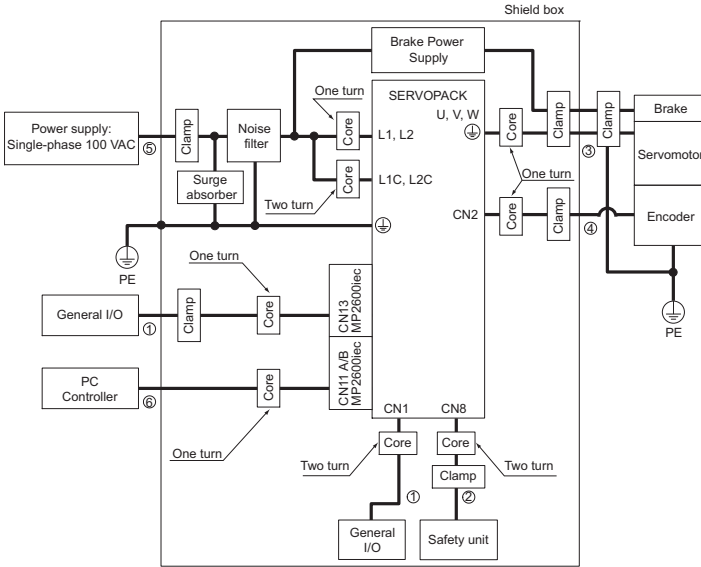

Symbol	Cable Name	Specification
①	I/O signal cable	Shield cable
②	Safety signal cable	Shield cable
③	Motor main circuit cable	Shield cable
④	Encoder cable	Shield cable
⑤	Main circuit cable	Shield cable
⑥	Ethernet communication cable	Shield cable

Three-phase 200 V

Models R70, R90, 1R6, 2R8, 3R8, 5R5, 7R6) + SGDV-OCC02A

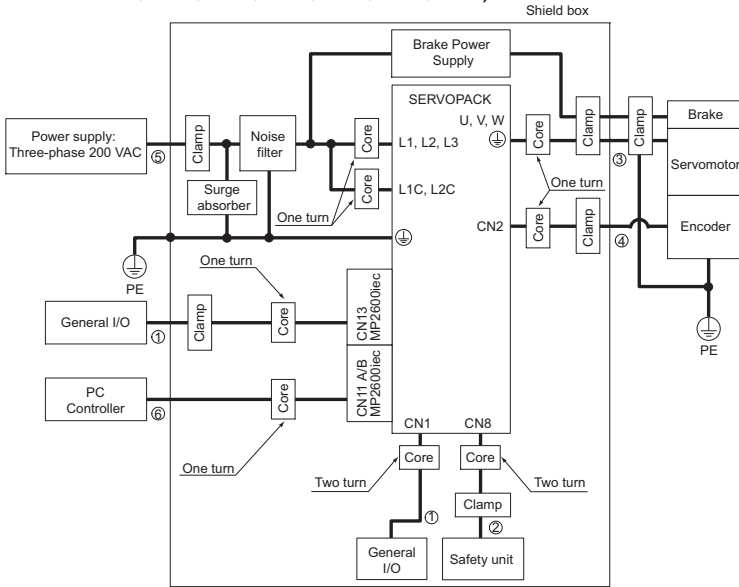

Symbol	Cable Name	Specification
①	I/O signal cable	Shield cable
②	Safety signal cable	Shield cable
③	Motor main circuit cable	Shield cable
④	Encoder cable	Shield cable
⑤	Main circuit cable	Shield cable
⑥	Ethernet communication cable	Shield cable

Three-phase 200 V
Model 120 + SGDV-OCC02A

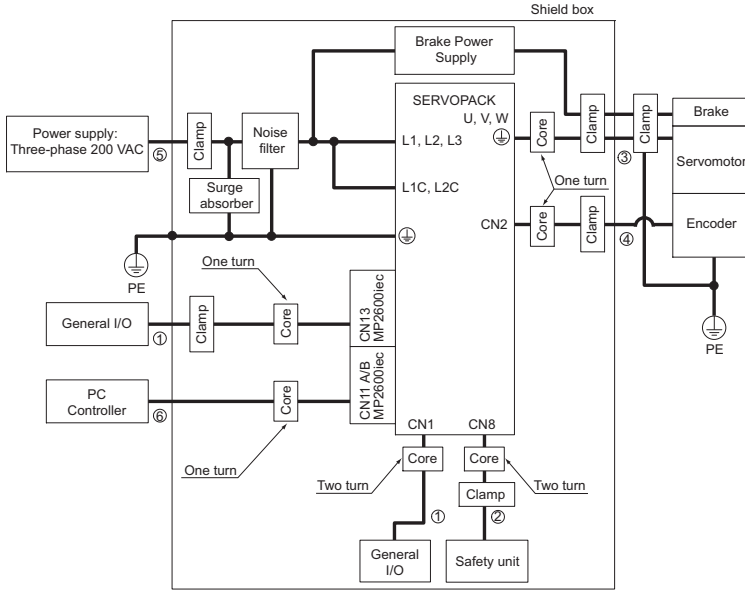

Symbol	Cable Name	Specification
①	I/O signal cable	Shield cable
②	Safety signal cable	Shield cable
③	Motor main circuit cable	Shield cable
④	Encoder cable	Shield cable
⑤	Main circuit cable	Shield cable
⑥	Ethernet communication cable	Shield cable

Three-phase 200 V Models 180, 200, 330 + SGD V-OCC02A

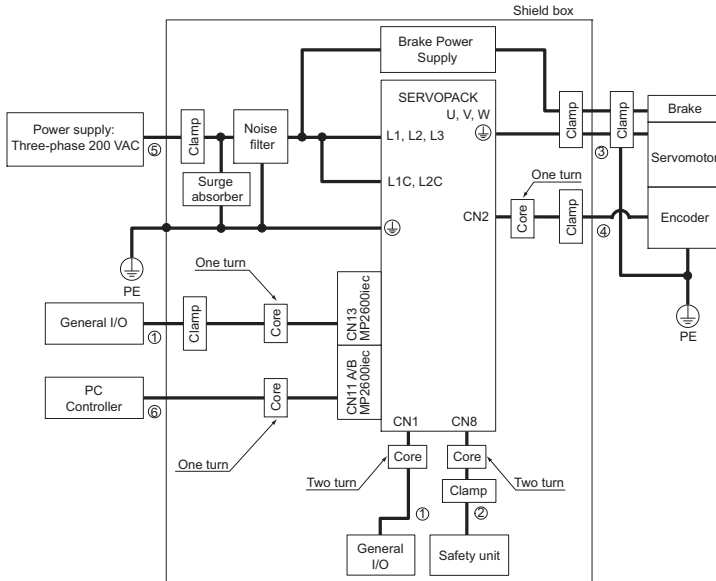

Symbol	Cable Name	Specification
①	I/O signal cable	Shield cable
②	Safety signal cable	Shield cable
③	Motor main circuit cable	Shield cable
④	Encoder cable	Shield cable
⑤	Main circuit cable	Shield cable
⑥	Ethernet communication cable	Shield cable

Three-phase 200 V
 Models 470, 550, 590, 780 + SGD V-OCC02A

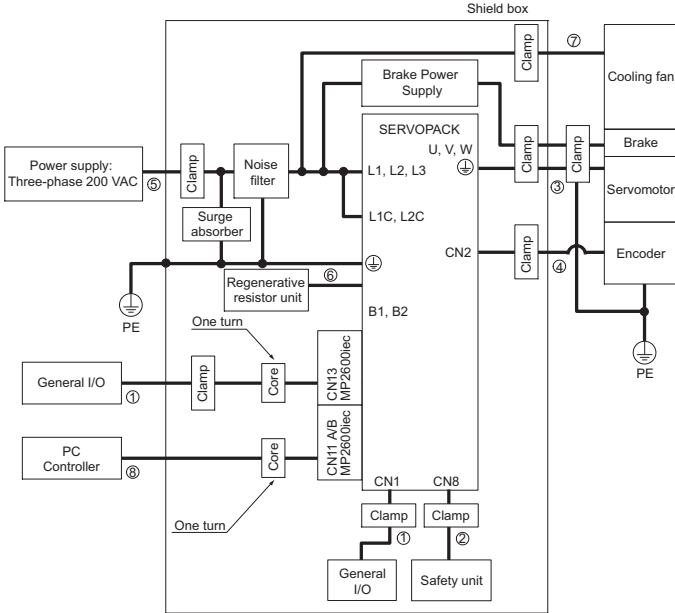

Symbol	Cable Name	Specification
①	I/O signal cable	Shield cable
②	Safety signal cable	Shield cable
③	Motor main circuit cable	Shield cable
④	Encoder cable	Shield cable
⑤	Main circuit cable	Shield cable
⑥	Regenerative resistor unit cable	Non-shield cable
⑦	Cooling fan cable	Shield cable
⑧	Ethernet communication cable	Shield cable

Three-phase 400 V Models 1R9, 3R5, 5R4, 8R4, 120, 170 + SGDV-OCC02A

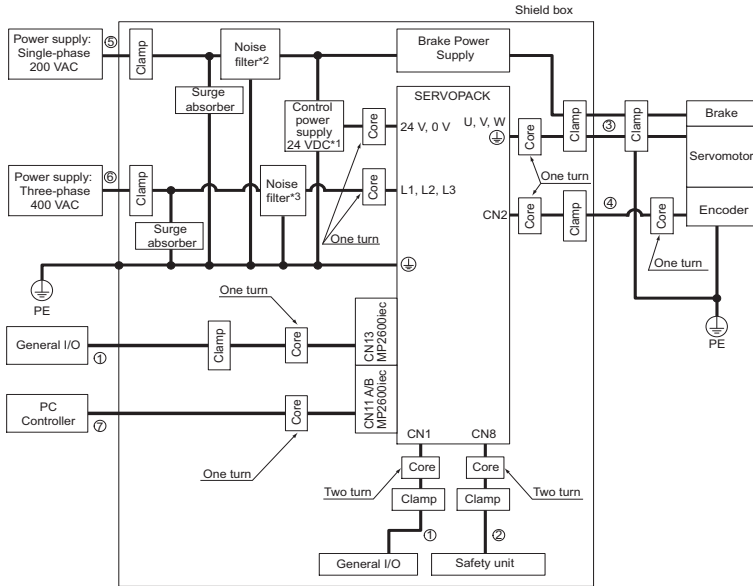

Symbol	Cable Name	Specification
①	I/O signal cable	Shield cable
②	Safety signal cable	Shield cable
③	Motor main circuit cable	Shield cable
④	Encoder cable	Shield cable
⑤	Control power cable	Shield cable
⑥	Main circuit cable	Shield cable
⑦	Ethernet communication cable	Shield cable

- * 1. Products that have received CE marking are recommended for the 24 VDC power supply.
- * 2. Install the following noise filter on the power line between the single-phase 200 V power supply and the 24 VDC power supply.
Model number: FN2070-6/07 (SCHAFFNER).
- * 3. For more information on this filter, refer to Sigma-5 Product Catalog (YEA-KAEPS80000042).

Three-phase 400 V Models 210, 260, 280, 370 + SGDV-OCC02A

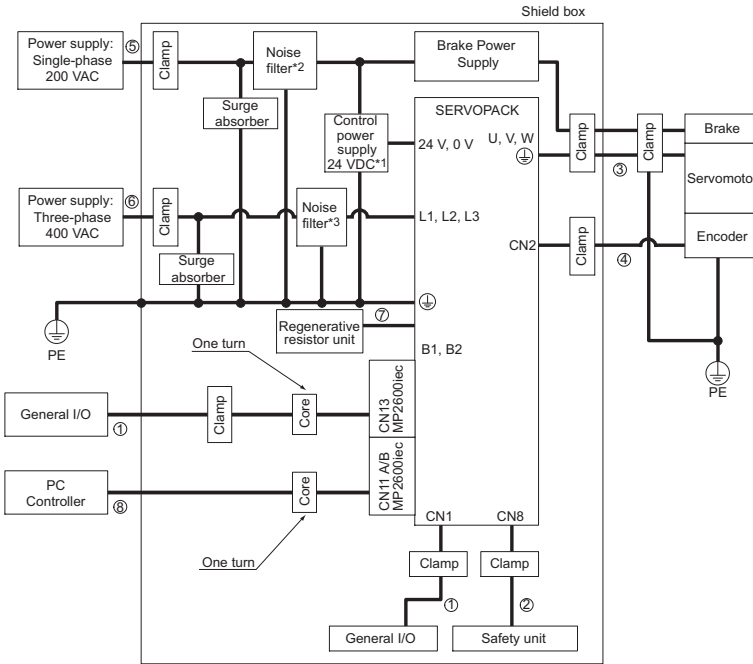

Symbol	Cable Name	Specification
①	I/O signal cable	Shield cable
②	Safety signal cable	Shield cable
③	Motor main circuit cable	Shield cable
④	Encoder cable	Shield cable
⑤	Control power cable	Shield cable
⑥	Main circuit cable	Shield cable
⑦	Regenerative resistor unit cable	Non-shield cable
⑧	Ethernet communication cable	Shield cable

- * 1. Products that have received CE marking are recommended for the 24 VDC power supply.
- * 2. Install the following noise filter on the power line between the single-phase 200 V power supply and the 24 VDC power supply.
Model number: FN2070-6/07 (SCHAFFNER).
- * 3. For more information on this filter, refer to Sigma-5 Product Catalog (YEA-KAEPS80000042).

Attachment Methods of Ferrite Cores

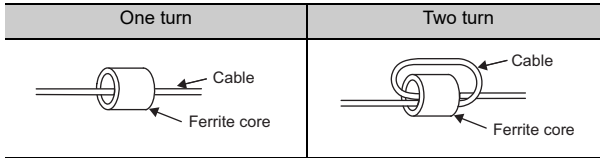

Recommended Ferrite Core

Cable Name	Ferrite Core Model	Manufacturer
Motor main circuit cable	ESD-SR-250	NEC TOKIN Corp.

Recommended Noise Filter and Surge Absorber

For more information on recommended noise filters and surge absorbers, refer to Sigma-5 Product Catalog. (YEA-KAEPS800000 42)

Fixing the Cable

Fix and ground the cable shield using a piece of conductive metal.

- Example of Cable Clamp

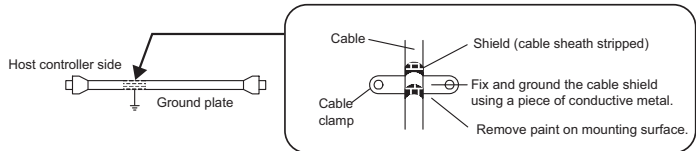

Shield Box

A shield box, which is a closed metallic enclosure, is effective as reinforced shielding against electromagnetic interference (EMI) from SERVOPACKs. The structure of the box should allow the main body, door, and cooling unit to be attached to the ground. The box opening should be as small as possible.

Note: Do not connect the digital operator and the analog monitor cable to the SERVOPACK during operations. Connect them only when the machinery is stopped during maintenance.

IRUMA BUSINESS CENTER (SOLUTION CENTER)

480, Kamifujisawa, Iruma, Saitama, 358-8555, Japan
Phone: 81-4-2962-5696 Fax: 81-4-2962-6138

YASKAWA ELECTRIC CORPORATION

New Pier Takeshiba South Tower, 1-16-1, Kaigan, Minatoku, Tokyo, 105-6891, Japan
Phone: 81-3-5402-4511 Fax: 81-3-5402-4580
<http://www.yaskawa.co.jp>

YASKAWA AMERICA, INC.

2121 Norman Drive South, Waukegan, IL 60085, U.S.A.
Phone: (800) YASKAWA (800-927-5292) or 1-847-887-7000 Fax: 1-847-887-7310
<http://www.yaskawa.com>

YASKAWA ELÉTRICO DO BRASIL, LTDA.

Avenida Piraporinha 777, Diadema, São Paulo, 09950-000, Brasil
Phone: 55-11-3585-1100 Fax: 55-11-3585-1187
<http://www.yaskawa.com.br>

YASKAWA ELECTRIC EUROPE GmbH

Hauptstraße 185, 65760 Eschborn, Germany
Phone: 49-6196-569-300 Fax: 49-6196-569-398

YASKAWA ELECTRIC UK LTD.

1 Hunt Hill Orchardton Woods, Cumbernauld, G68 9LF, United Kingdom
Phone: 44-1236-735000 Fax: 44-1236-458182

YASKAWA ELECTRIC KOREA CORPORATION

7F, Doore Bldg. 24, Yeoido-dong, Youngdungpo-Ku, Seoul, 150-877, Korea
Phone: 82-2-784-7844 Fax: 82-2-784-8495

YASKAWA ELECTRIC (SINGAPORE) PTE. LTD.

151 Lorong Chuan, #04-01, New Tech Park, 556741, Singapore
Phone: 65-6282-3003 Fax: 65-6289-3003

YASKAWA ELECTRIC (SHANGHAI) CO., LTD.

No. 18 Xizang Zhong Road, Room 1702-1707, Harbour Ring Plaza, Shanghai, 200001, China
Phone: 86-21-5385-2200 Fax: 86-21-5385-3299

YASKAWA ELECTRIC (SHANGHAI) CO., LTD. BEIJING OFFICE

Room 1011A, Tower W3 Oriental Plaza, No. 1 East Chang An Ave.,
Dong Cheng District, Beijing, 100738, China
Phone: 86-10-8518-4086 Fax: 86-10-8518-4082

YASKAWA ELECTRIC TAIWAN CORPORATION

9F, 16, Nanking E. Rd., Sec. 3, Taipei, Taiwan
Phone: 886-2-2502-5003 Fax: 886-2-2505-1280