



BUFFER UNIT

- Buffering with electrolytic capacitors instead of lead batteries
- Buffering of 24V loads
- Minimum hold-up time 0.2s at 20A
- Longer hold-up time at lower loads
- Clear status indication by status LED and signaling terminals
- Quick-connect spring-clamp terminals
- 3 Year warranty

1. GENERAL DESCRIPTION

The buffer unit is a supplementary device for regulated DC24V power supplies. It buffers load currents during typical mains faults and load peaks.

Working principle

In times when the power supply provides sufficient voltages, the buffer unit stores energy in integrated electrolytic capacitors. In case of mains voltage fault, this energy is released again in a regulated process.

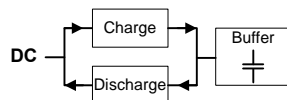

Bridges mains faults without interruption

Statistic show that 80% of all mains fault lasts less than 0.2s. These mains faults are completely bridged by the buffer unit. This increases the reliability of the system as a whole.

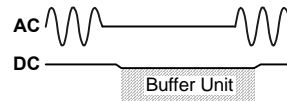

Extended hold-up time

Once mains power fails or is switched off, the buffer unit will continue to provide the load current for a defined period of time. Process data can be saved and processes can be terminated before the DC power switches off. Controlled restarts are subsequently possible.

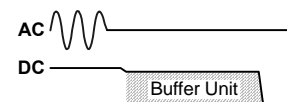

2. SHORT-FORM DATA

Rated voltage	DC 24V	
Voltage range	24-28.8V	
Output voltage	22.5V or $V_{IN} - 1V$	selectable by jumper
Output current	0 to 20A	
Hold-up time	min 0.2s	22.5V, 20A
	typ 0.31s	22.5V, 20A
	min 28s	22.5V, 0.1A
	typ 43s	22.5V, 0.1A
Charging current	max 600mA	
Charging time	typ 18s	
Input current	typ 80mA	standby mode
Power dissipation	typ 1.9W	standby mode
Temperature range	-25°C to +70°C	operational
Dimensions	64x124x102mm	WxHxD

Easy to handle, expandable and maintenance-free

The buffer unit does not require any control wiring. It can be added parallel to the load circuit at any given point. Buffer units can be switched in parallel to increase the output ampacity or the hold-up time.

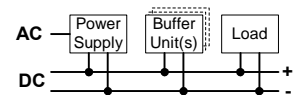

3. ORDER NUMBERS

Buffer Unit	UF20.241	24, 20A, 200ms
Accessory	ZM1.WALL	Wall mounting bracket
	ZM14.SIDE	Side mounting bracket
	XF-1x4s/270-60	Mating connector, Part of delivery

4. MARKINGS



INDEX PAGE

1. General Description	1
2. Short-form Data	1
3. Order Numbers.....	1
4. Markings	1
5. Standby Mode	3
6. Charging Mode	3
7. Buffer Mode	4
8. Functional Diagram.....	5
9. Front Side and User Elements.....	5
10. Operating Diagram	6
11. Active and Ready Signal, Inhibit Input	6

INDEX PAGE

12. Terminals and Wiring	7
13. Reliability	7
14. EMC.....	8
15. Environment.....	8
16. Protection Features.....	9
17. Safety	9
18. Approvals.....	9
19. Fulfilled Standards	9
20. Physical Dimensions and Weight	10
21. Wiring Diagrams	11

INSTALLATION NOTES

Mounting Orientation:

The power terminal shall be located on top of the unit.

Cooling

Convection cooled, no forced air cooling required. Do not obstruct air flow!

Installation clearances:

Recommended installation clearances:

40mm on top of the unit,

20mm on the bottom of the unit,

0mm (or 15mm in case the adjacent device is a heat source) on the left and right side of the unit

Intended use

This buffer unit has been designed for use in panel board installations or other building-in applications where a suitable mechanical enclosure shall be provided to fulfil local requirements.

Service parts:

The unit does not contain any service parts. If damage or malfunctioning should occur during operation, immediately turn power off and send unit for inspection to factory!

DISCLAIMER

The information presented in this document is believed to be accurate and reliable and may change without notice.

5. STANDBY MODE

Input voltage	nom.	DC 24V	
Voltage range	nom.	24-28.8Vdc	
Input current	typ.	80mA	Standby mode
Power dissipation	typ.	1.9W	
Status lamp		permanent on	
Active signal		high ohmic	
Ready signal		low ohmic	

6. CHARGING MODE

Charging current	min.	0.4A	Charging mode
	max.	0.6A	Charging mode
Charging time	min.	20s / 15s	Initial charge ¹⁾ / Re-charging ²⁾
	max.	29s / 21s	Initial charge ¹⁾ / Re-charging ²⁾
Status lamp		flashes 1.25Hz	
Active signal		high ohmic	
Ready signal		high ohmic	

1) Initial charging is the first charge after voltage is applied to the buffer unit.

2) Re-charging is the charging of the internal capacitors after voltage interruptions shorter than 2minutes.

Fig. 6-1 Re-charging time, 24V

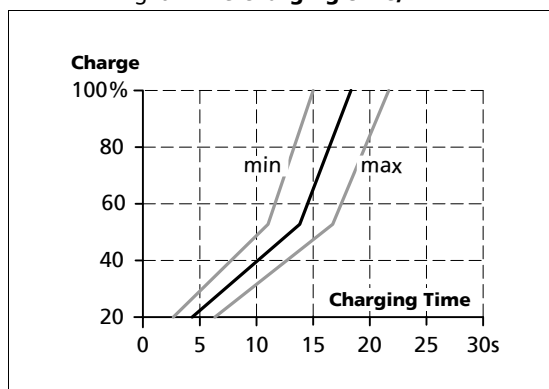

7. BUFFER MODE

Rated output current	nom.	20A	
Current limitation	min.	20A	Electronically limited
Output voltage	typ.	22.5V	Jumper in position "22.5V fixed"
	typ.	1V below input voltage	Jumper in position "Vin -1V"
Ripple and noise voltage	max.	200mVpp	20Hz to 20MHz, 50Ohm
Hold-up time	min.	0.2s	22.5V, 20A
	typ.	0.31s	22.5V, 20A
	min.	28s	22.5V, 0.1A
	typ.	43s	22.5V, 0.1A
To increase buffer current or extend hold-up time any given number of buffer units can be put in parallel			
Activation threshold	typ.	22.5V	Jumper in position "22.5V fixed" Buffering starts if terminal voltage falls below 22.5V
	typ.	Vin -1V	Jumper in position "Vin -1V" Buffering starts if the terminal voltage decreases by more than 1V. Buffering ends when terminal voltage increases by more than 1V Voltage changes slower than 0.54V/s will be ignored unless the voltage is above 22.5V. Below 22.5V buffering starts immediately.
Status lamp		flashes 10Hz	
Active signal		low ohmic	
Ready signal		high ohmic	

Fig. 7-1 Hold-up time

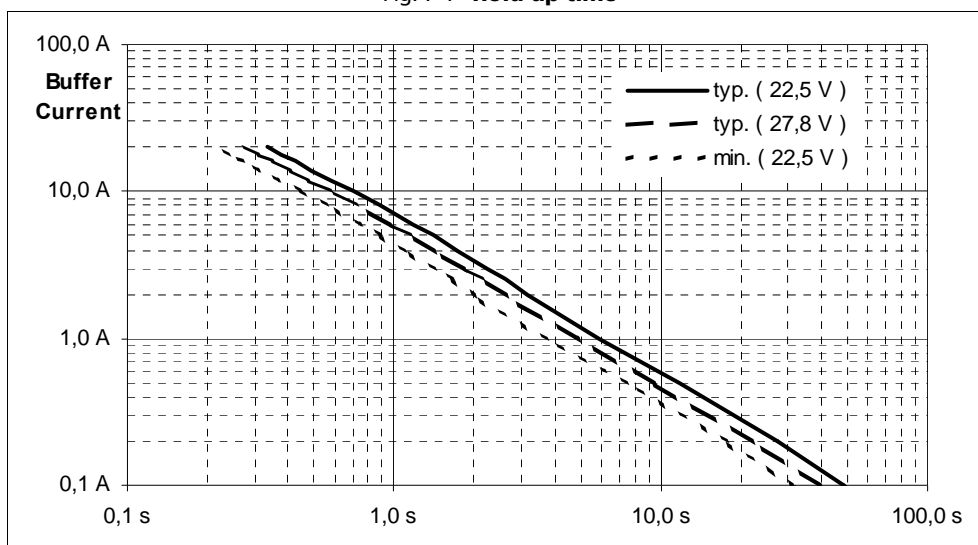

8. FUNCTIONAL DIAGRAM

Fig. 8-1 Functional diagram

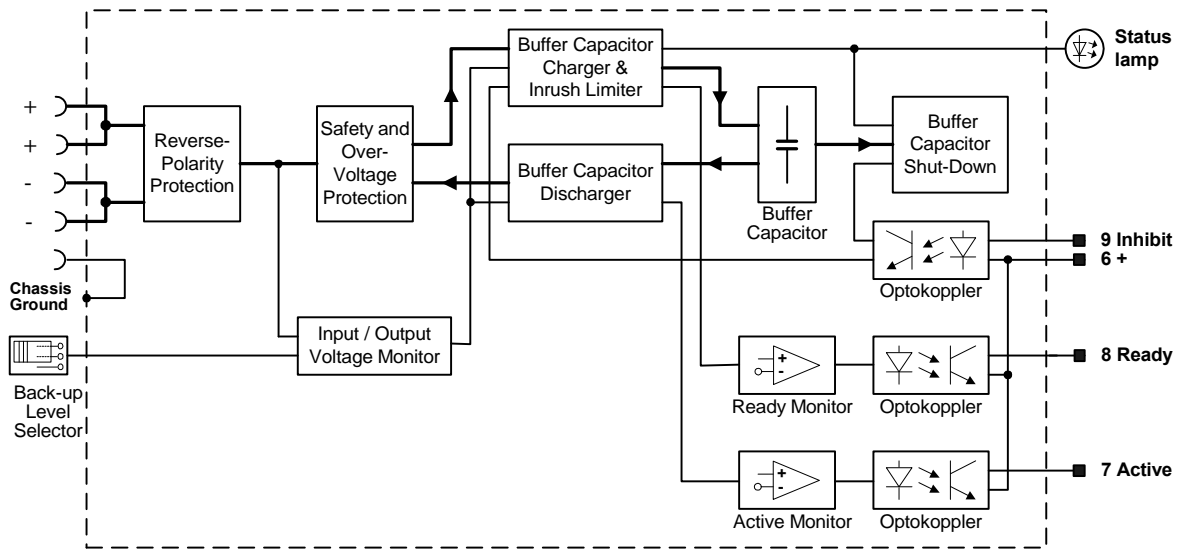

9. FRONT SIDE AND USER ELEMENTS

Fig. 9-1 Front side

I/O Power Port
Quick-connect spring-clamp terminals,

- + Positive terminal
- Negative terminal

Chassis Ground
to bond the housing

Status lamp

OFF: Buffer is discharged, or terminal voltage is below 22V

ON: Unit is fully charged

Flashes 1,25Hz:

Unit is in charging mode

Flashes 10Hz:

Unit is in discharging mode

Signal Port

Plug Connector

6 common + pole

7 Active: unit is buffering

8 Ready: unit is on stand-by

9 Inhibit: initiates buffer discharging and inhibits recharging of capacitors

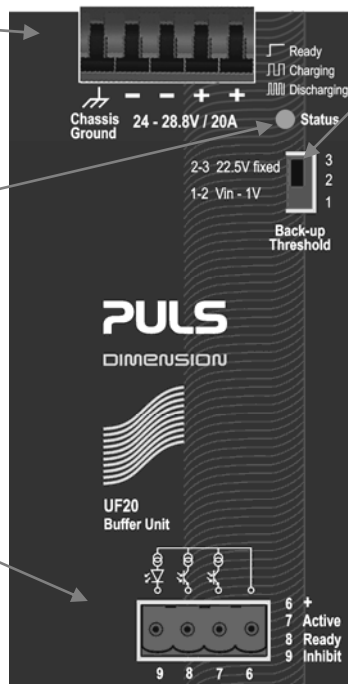

Back-up threshold jumper

1-2: Variable mode

Unit switches to buffer mode when input voltage decreases by 1V within 0.54V/s or the input voltage falls below 22.5V.

2-3: Fixed mode, (factory setting)

Unit switches to buffer mode as soon as the voltage falls below 22.5V

Missing jumper = 22.5V fixed

Set the unit to fixed mode:

- when power supplies other than the Dimension Q-Series are used
- with back-feeding loads
- when the buffer unit is placed close to the load
- whenever in doubt

Set the unit to variable mode:

- for 28V applications
- when the buffer unit is placed close to the power supply

10. OPERATING DIAGRAM

Fig. 10-1 Operating diagram

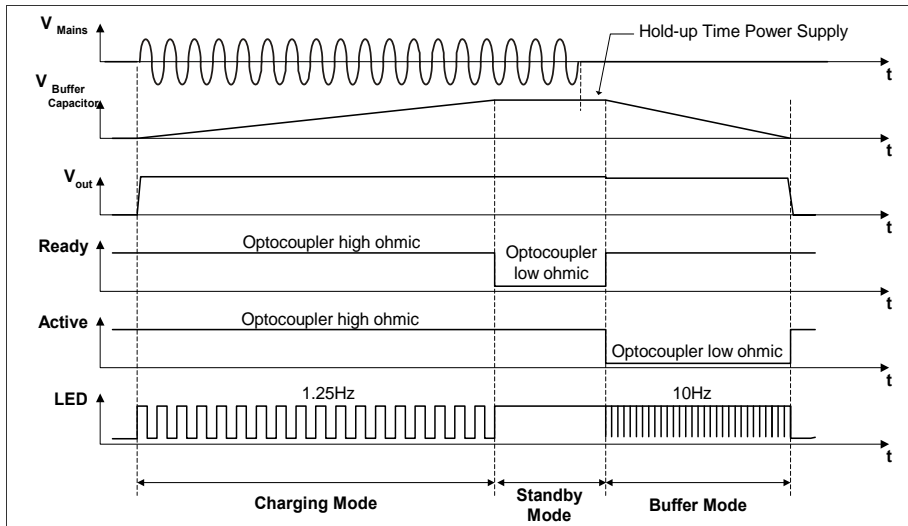
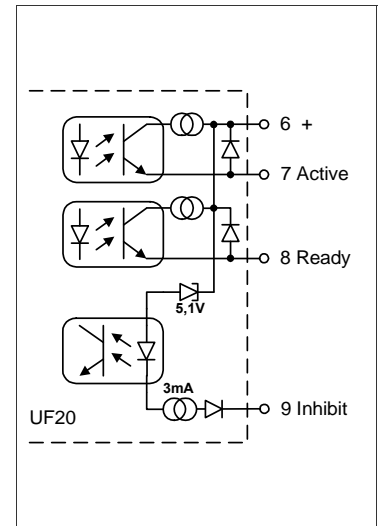

Fig. 10-2 Signals schematic



11. ACTIVE AND READY SIGNAL, INHIBIT INPUT

Active signal (Pin 7)		low ohmic while buffer capacitors are discharging
Signal voltage	max.	35Vdc
Signal current	max.	10mA
Voltage drop across opto-coupler	typ	0.9V / 3V at 1mA / 5mA, while opto-coupler is low ohmic
Leakage current	max.	50µA while opto-coupler is high ohmic
Isolation	nom.	500Vac Signal port to power port
Ready signal (Pin 8)		low ohmic when buffer is fully charged
Signal voltage	max.	35Vdc
Signal current	max.	10mA
Voltage drop across opto-coupler	typ	0.9V / 3V at 1mA / 5mA, while opto-coupler is low ohmic
Leakage current	max.	50µA while opto-coupler is high ohmic
Isolation	nom.	500Vac Signal port to power port
Inhibit input (Pin 9)		"High" input signal initiates unit shutdown and buffer discharge
Signal voltage	max.	35Vdc
Signal current	max.	4mA current limited
Shut-down threshold	min.	6Vdc Unit is in shut-down mode above this threshold level
	max.	10Vdc
Isolation	nom.	500Vac Signal port to power port

Wiring diagrams can be found in section 21.

12. TERMINALS AND WIRING

Power terminal

Type	Bi-stable, quick-connect spring clamp terminals. IP20 Finger safe construction. Suitable for field- and factory installation. Shipped in open position.
Solid wire	0.5-6mm ²
Stranded wire	0.5-4mm ²
AWG	20-10AWG
Ferrules	Allowed, but not required
Pull-out force	10AWG:80N, 12AWG:60N, 14AWG:50N, 16AWG:40N (according to UL486E)
Wire stripping length	10mm / 0.4inch

Instructions:

- Use appropriate copper cables, that are designed for an operating temperature of 60°C
- Follow national installation codes and regulations!
- Ensure that all strands of a stranded wire enter the terminal connection!
- Up to two stranded wires with the same cross section are permitted in one connection point

Fig. 12-1 Connecting a wire

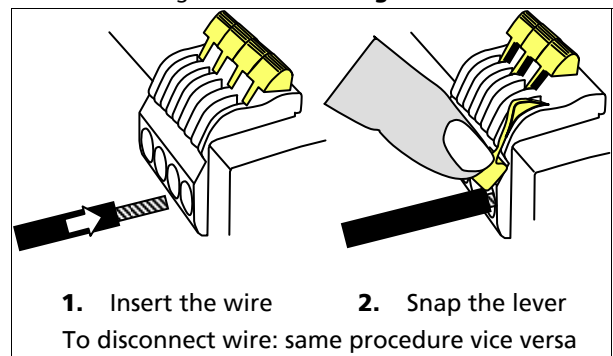

Signal terminal

Type	Plug connector with screw terminal mechanism. Finger-touch-proof terminal with captive screws for 3.5mm slotted screwdriver.
Solid / stranded wire	0.2-2.5mm ²
AWG	22-14AWG
Ferrules	up to 1.5 mm ² wire gauge
Wire stripping length	6mm / 0.24inch
Tightening torque	0.4Nm, 3.5lb.in

13. RELIABILITY

Lifetime expectancy	min.	41 000h	40°C, stand-by mode
	min.	116 000h	25°C, stand-by mode
MTBF SN 29500, IEC 61709		2 327 000h	40°C, stand-by mode
		4 219 000h	25°C, stand-by mode
MTBF MIL HDBK 217F		398 000h	40°C, stand-by mode, ground benign GB40
		624 000h	25°C, stand-by mode, ground benign GB25

The **Lifetime expectancy** shown in the table indicates the operating hours (service life) and is determined by the lifetime expectancy of the built-in electrolytic capacitors. Lifetime expectancy is specified in operational hours. Lifetime expectancy is calculated according to the capacitor's manufacturer specification.

MTBF stands for **Mean Time Between Failure**, which is calculated according to the statistically device failures, and indicates reliability of a device. It is the statistical representation of the likelihood of a unit to fail and does not necessarily represent a life of a product.

14. EMC

The unit is suitable for applications in industrial environment as well as in residential, commercial and light industry environment without any restrictions. CE mark is in conformance with EMC guideline 89/336/EEC and 93/68/EEC and the low-voltage directive (LVD) 73/23/EWG.

A detailed EMC Report is available on request

EMC Immunity	EN 61000-6-1 EN 61000-6-2		Generic standards	
Electrostatic discharge 1)	EN 61000-4-2	Contact discharge	8kV	Criterion A
		Air discharge	15kV	Criterion A
Electromagnetic RF field	EN 61000-4-3	80MHz-1GHz	10V/m	Criterion A
Fast transients (Burst)	EN 61000-4-4		2kV	Criterion A
Surge voltage	EN 61000-4-5	+ → -	500V	Criterion A
		+ / - → housing	500V	Criterion A
Conducted disturbance	EN 61000-4-6	0,15-80MHz	10V	Criterion A

1) Din-Rail earthed

EMC Emission	EN 61000-6-3 and EN 61000-6-4		Generic standards	
Conducted emission	EN 55022		Class B	
Radiated emission	EN 55011, EN 55022		Class B	

This device complies with FCC Part 15 rules.

Operation is subjected to following two conditions: (1) this device may not cause harmful interference, and (2) this device must accept any interference received, including interference that may cause undesired operation.

15. ENVIRONMENT

Operational temperature	-25°C to +70°C	full power
Storage temperature	-40 to +85°C	storage and transportation
Humidity	5 to 95% r.H.	no condensation allowed
Vibration sinusoidal	2-17.8Hz: ±1.6mm; 17.8-500Hz: 2g	IEC 60068-2-6
Vibration random	0.5m ² (s ³)	IEC 60068-2-64
Shock	30g 6ms, 20g 11ms	IEC 60068-2-27
Altitude	0 to 6000m	All approvals apply only up to 2000m
Over-voltage category	III	EN 50178
	II	EN 50178 above 2000m altitude
Degree of pollution	2	EN 50178, not conductive

The ambient temperature is defined 2cm below the unit.



16. PROTECTION FEATURES

Buffer protection	Electronically protected against overload, no-load and short-circuits	
Output over-voltage protection in buffer mode	typ. 32Vdc max. 35Vdc	In case of an internal defect, a redundant circuitry limits the maximum output voltage. The output shuts-down and makes restart attempts automatically.
Degree of protection	IP 20	EN/IEC 60529
Penetration protection	> 3.5mm	e.g. screws, small parts
Reverse polarity protection	yes	max. -35Vdc
Input over-voltages protection	yes	max. 35Vdc, no harm or defect of the unit
Internal fuse	not included	

17. SAFETY

Output voltage	SELV PELV	IEC/EN 60950-1 EN 60204-1, EN 50178, IEC 60364-4-41
Class of protection	II	
Isolation resistance	> 5MΩ	Power port to housing, 500Vdc
PE resistance	< 0.1Ω	between housing and chassis ground terminal
Dielectric strength	500Vac	Power port to signal port
	500Vac	Power port / signal port to housing

18. APPROVALS

UL 508		LISTED E198865 listed for use in U.S.A. (UL 508) and Canada (C22.2 No. 14-95) Industrial Control Equipment
UL 60950-1		RECOGNIZED E137006 recognized for the use in U.S.A. (UL 60950-1) and Canada (C22.2 No. 60950) Information Technology Equipment, Level 5
IEC 60950-1		CB Scheme, Information Technology Equipment

19. FULFILLED STANDARDS

EN/IEC 60204-1	Safety of Electrical Equipment of Machines
EN/IEC 61131	Programmable Controllers
EN 50178	Electronic Equipment in Power Installations

20. PHYSICAL DIMENSIONS AND WEIGHT

Width	64mm / 2.51"
Height	124mm / 4.88"
Depth	102mm / 4.02" plus depth of DIN-rail and depth of signal connector
Weight	740g / 1.63lb
DIN-Rail	Use DIN-rails according to EN 60715 or EN 50022 with a height of 7.5 or 15mm

Fig. 20-1 **Side view**

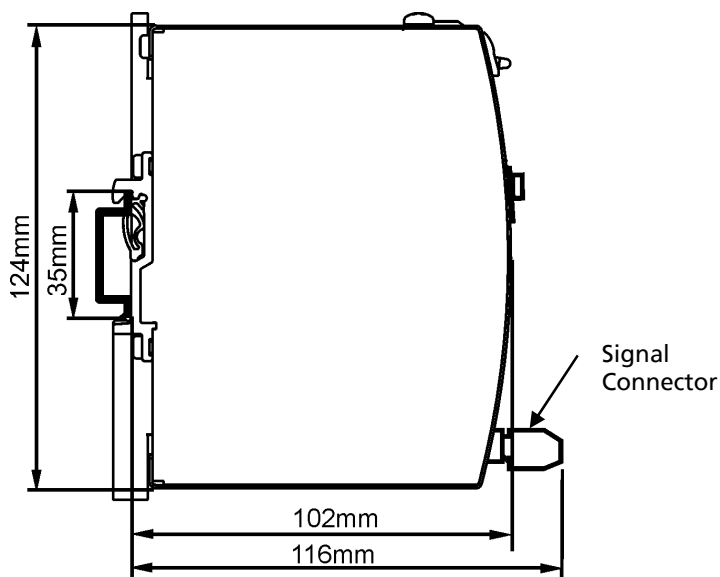
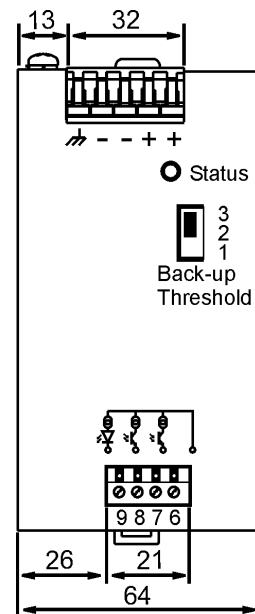

Fig. 20-2 **Front view**



21. WIRING DIAGRAMS

Fig. 21-1 General wiring diagram

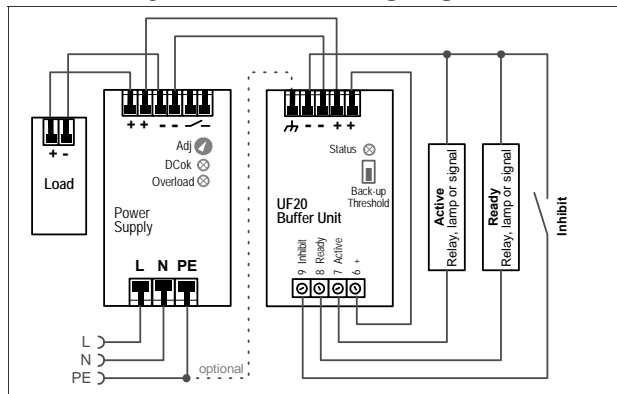

Fig. 21-2 Signals supplied from an external voltage

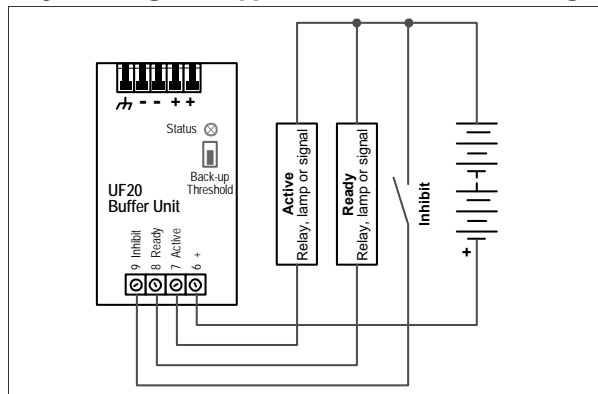

Fig. 21-3 Paralleling of buffer units

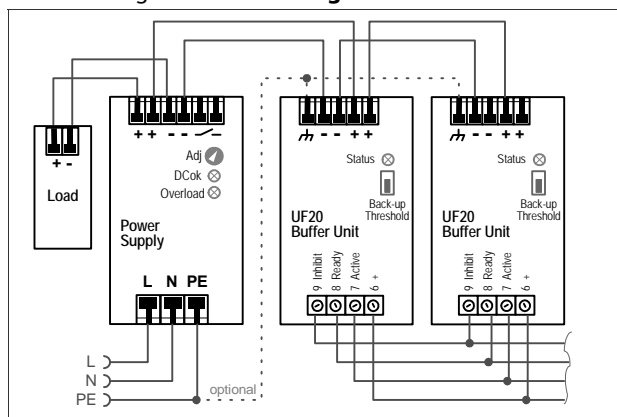

Fig. 21-4 Decoupling of buffered branches

